

SOYO – G668 VOIP – IP PHONE USER MANUAL



INGLOS NETWORKS -
INDUSTRIAL GLOBAL SOLUTIONS
27 WESTOVER DRIVE
WEBSTER NY 14580
TEL: + (585) 217-9864
FAX: + (585) 872-9627



APPROVED VENDOR FOR SOYO GROUP



User Manual

Table of Content

SAFETY INFORMATION	1
INTRODUCTION	1
Configuration with a Single Computer	1
Configuration within a Home or Office Network	2
Package Contents	3
Front Panel of SOYO G668 IP phone	4
Rear Side of SOYO G668 IP phone	6
INSTALLATION	7
Installation with a Single Computer	7
Installation within a Home or Office Network	9
CONFIGURATION VIA IP PHONE KEYPAD	11
Configuration for DHCP (default)	11
Entering Configuration Mode	11
Configuration for PPPoE	12
Configuration for Static IP	12
CONFIGURATION VIA WEB BROWSER	14
Network Settings	14
Protocol Settings	15
Phone Settings	16
Other Settings	17
Save/Reboot	17
Address Book	17
SOFTWARE UPGRADING	19
TROUBLESHOOTING	20
APPENDIX: PORT FORWARDING	22

Safety Information

The SOYO IP Phone has been tested and approved by the highest standards of safety regulations. However safety is your responsibility too.

- Use only the power adapter provided
- Do not disassemble this product without guidance, no serviceable parts for user.
- Never spill liquid of any kind on the product
- Do not cut power off in the process of configuration and upgrading

*The specifications herein may subject to change without notice. Therefore please visit our website at <http://phone.soyo.com> for latest update and amendment.

Introduction

SOYO G668 IP phone is an advanced Internet Protocol (IP) device, allowing its users to experience superb voice communications over the Internet. It works as a standalone device (no PC is needed) with any broadband Internet connection. This Internet connection can be either:

- A Digital Subscriber Line (DSL) Internet service from a telephone company
- A cable modem Internet service from a cable television company
- Other high-speed Internet connection such as ISDN and T1

You can use G668 IP phone in your home or office network with any broadband DSL or Cable modem, Ethernet router, switch and your computer.

Configuration with a Single Computer

You can connect G668 IP phone directly to any broadband modem, and continue to surf the internet using your computer:

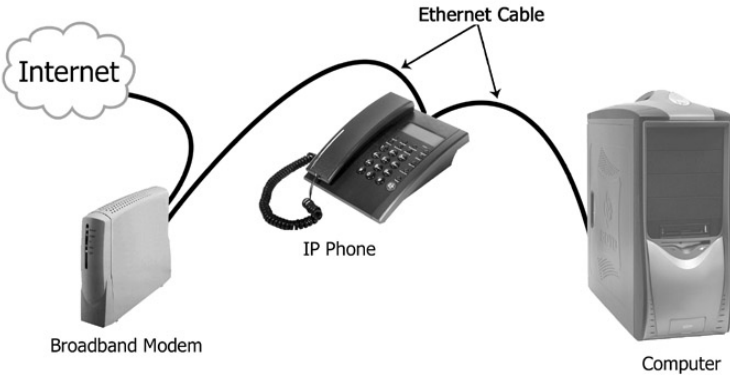

Note: Some Internet Service Providers provide only one public IP address. Therefore the computer and the IP phone can not be online at the same time. Please refer to the following configuration.

Configuration within a Home or Office Network

You can connect G668 IP phone to any router on a network with broadband Internet connection such as DSL, Cable or T1.

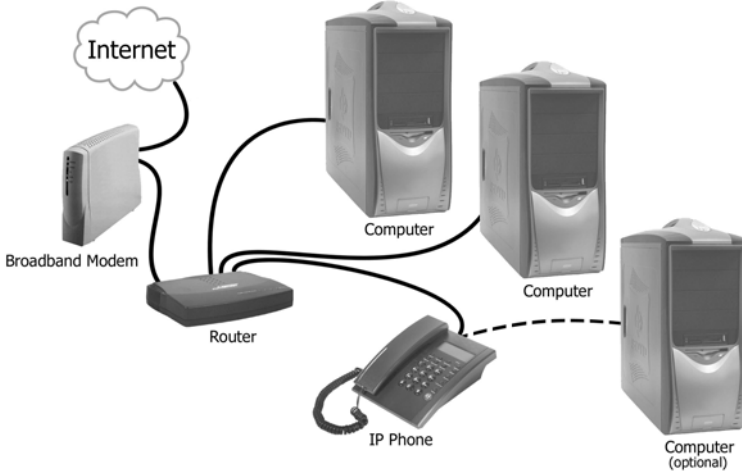

Package Contents

Make sure the following contents are included in the G668 IP phone package:

- One SOYO G668 IP phone
- One DC 7.5V 0.45A Power Adapter
- User Manual
- One Ethernet RJ-45 Cable



SOYO G668 IP phone



Power Adapter





User Manual

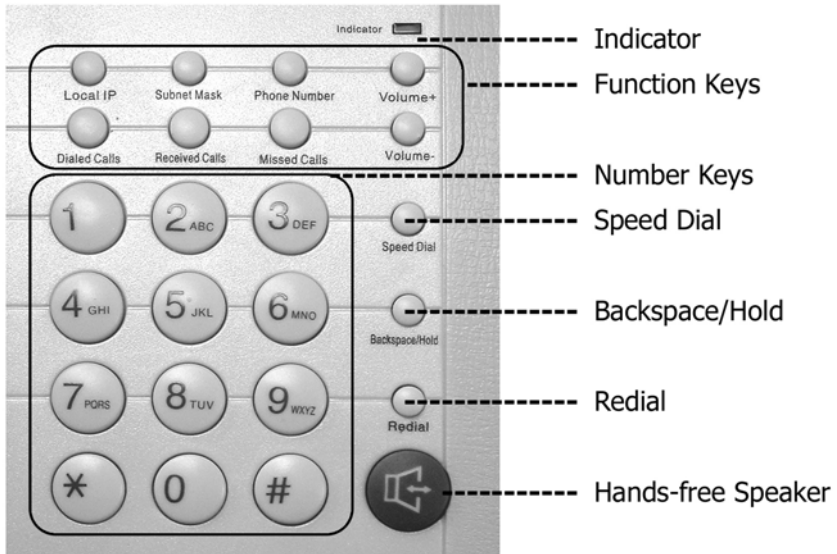

Ethernet RJ-45 Cable

Front Panel of SOYO G668 IP phone



Keys	Functions
Local IP	Without lifting the handset, press to get the IP address of this IP phone
Subnet Mask	Without lifting the handset, press to get the Subnet Mask
Phone Number	Without lifting the handset, press to get the phone number
Dialed Calls	Without lifting the handset, press to get the list of the dialed numbers
Received Calls	Without lifting the handset, press to get the list of the received numbers
Missed Calls	Without lifting the handset, press to get the list of the missed call numbers
Speed Dial	Use the number key pad to enter the speed dial number position of the phone book entry, and press "speed dial" to connect (refer to page 17 for detail)
Backspace/Hold	Press this key to put a call on hold
Redial	Redial the last dialed phone number
Speaker 	Press this key to make a call without lifting the handset
Volume +	Increase the volumes of handset or speaker;
Volume -	Decrease the volumes of handset or speaker;

Rear Side of SOYO G668 IP phone

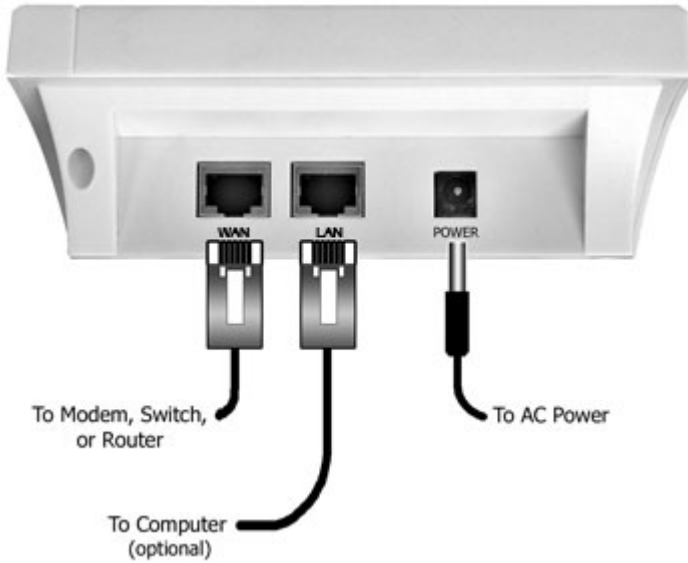

Installation

Depending on your network environment, you will need to perform one of the following installations:

Installation with a Single Computer

Installation with a Home or Office Network

Installation with a Single Computer

 **Note:** Some Internet Service Providers provide only one public IP address. Therefore the computer and the IP phone can NOT be online at the same time. Using a router is highly recommended.

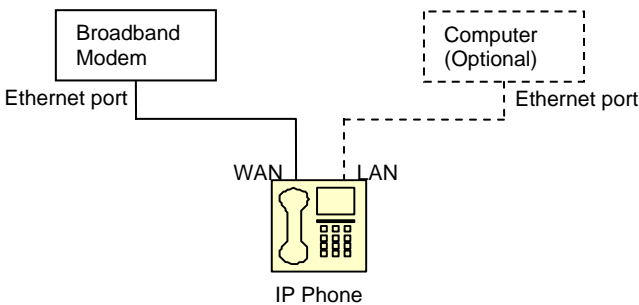

1. Connect one end of the Ethernet RJ-45 cable to the broadband modem, and connect the other end of the cable to one of the RJ-45 WAN ports at the rear of the G668 IP phone.
2. Connect one end of another Ethernet RJ-45 cable to your computer, and connect the other end of the same cable to the LAN ports at the rear of the G668 IP phone. (This is an optional step. IP phone can work without the computer)
3. Connect the power adapter to the AC outlet and the power jack at the rear of G668 IP phone.
4. Once the IP Phone is powered up, the booting sequence will begin. You will see the following information displayed on the LCD screen:

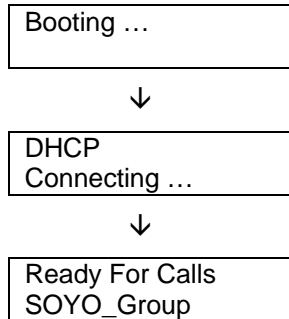

5. If “Ready for Calls” appears on the LCD screen as shown above, your IP phone is ready to use. Now you can pick up the hand set and start making phone calls. Important: It may take about 20 seconds for the phone to initialize during setup, please be patient and wait till the initialization completed.
6. If you are using a DSL modem and the LCD screen displayed “Wait Logon...” or “Logon Failed”, you may need to enable the PPPoE setting on your IP phone as described in “Configuration for PPPoE” section on page 12.
7. If you are using a static IP for the phone and you see “Wait Logon...” on LCD display, you may need to change the IP setting on your IP phone as described in “Configuration for Static IP” section on page12.
8. If you still have problems logging on, please refer to “Troubleshooting” on page 20. If problem persist then contact your VoIP provider.

Installation within a Home or Office Network

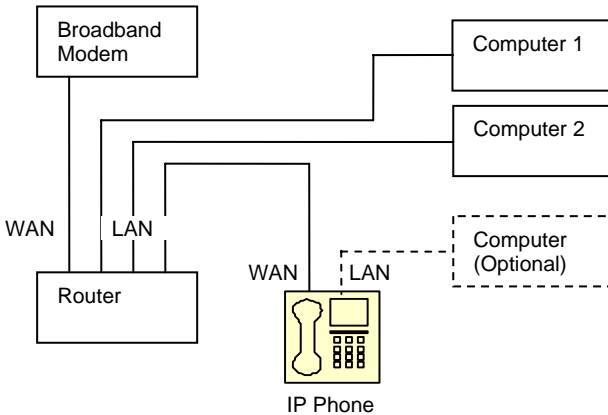

1. Connect one end of the Ethernet RJ-45 cable to an open Ethernet LAN port on your router, and connect the other end of the cable to the WAN port at the rear of the G668 IP phone.
2. Using another RJ-45 cable, you can connect one end of the Ethernet RJ-45 cable to your computer, and connect the other end to the LAN port at the rear of the G668 IP phone. (This is an optional step. IP phone can work without the computer)
3. Connect the power adapter to the AC outlet and the power jack at the rear of G668 IP phone.
4. Once the IP Phone is powered up, the booting sequence will begin. You will see the following information displayed on the LCD screen:

Booting ...



DHCP
Connecting ...



Ready For Calls
SOYO_Group

5. If “Ready for Calls” appears on the LCD as above, your IP phone is ready to use. Now you can pick up the hand set and start making phone calls.
6. If you still have problems logging on, please refer to “Troubleshooting” on page 20. If problem persist then contact your VoIP provider.

Configuration via IP Phone Keypad

Configuration for DHCP (default)

The SOYO-G668's default setting is set on DHCP enabled. If you have a router with DHCP support, or if you connect the IP phone directly to the cable modem with dynamic IP address from the ISP, you don't need to perform any of the following configurations.

If you are using PPPoE or static IP, you will need to follow the instructions below to setup the phone. Please make sure the IP phone is powered on and all the cables are securely connected before performing the following:

Entering Configuration Mode

Go to the dial pad and press "Hand-free Speaker" (or picking up the handset) and enter 1234 (the default code), and press the "#" button until the screen display read "Password" then enter 1234 again, press "Hand-free Speaker". "Network Settings" will be displayed on the LCD screen. You have entered the "Network Settings" menu and you are ready to configure your IP Phone.

This is a list of functions corresponding to the "keys".

Keys	Function
<i>Local IP</i>	Enter change mode to change parameter
<i>Speaker</i>	Enter Sub-menu, confirm changes
<i>Redial</i>	Exit current manual, exit change mode
<i>Volume+</i>	Turn over manual backward
<i>Volume-</i>	Turn over manual forward, move cursor back in change mode
<i>Number Keys</i>	Modify parameters

 **Note:** Press "#" to shift between upper and lower case.

Configuration for PPPoE

This setting is for users using DSL modem without a router. You will need the username and password from you ISP to setup your IP phone.

Please make sure you have entered the “networking settings” before proceeding.

<u>LCD SCREEN</u>	<u>INSTRUCTION</u>
network settings	Press Speaker
ip type 1 [DHCP]	Press Local IP , then 2 , then press Speaker
ip type 2 [PPPoE]	Press Volume+ , until you see “pppid”
pppid	Press Local IP , input DSL user’s name, then press Speaker
pppin	Press Local IP , input DSL pin, press Speaker , then press Redial until you see “save settings”
save settings	Press Speaker
save are you sure?	Press Speaker again to confirm the changes
Ready for calls SOYO_Group	Allow a few seconds for the system to boot the new configuration and you are ready to make calls

Configuration for Static IP

If your ISP gives you a static IP address, you will need to configure your IP phone based on following instruction. Please have the static IP address, subnet mask, router address, and DNS address ready from your web administrator or ISP.

Please make sure you have entered the “networking settings” before proceeding.

<u>LCD SCREEN</u>	<u>INSTRUCTION</u>
network settings	Press Speaker
ip type 1 [DHCP]	Press Local IP , then 0 , then Speaker
ip type 2 [PPPoE]	Press Volume+ , until you see “ip”
ip	Press Local IP , input your static IP and press Speaker , then press Volume+ until you see “subnetmask”
subnetmask	Press Local IP , input specific network mask and press Speaker , then press Volume+ until you see “router”
router	Press Local IP , input specific router IP and press Speaker , then press Volume+ until you see “dns”
dns	Press Local IP , input specific DNS address and press Speaker , then press Redial until you see “save settings”
save settings	Press Speaker
save Are you sure?	Press Speaker to confirm the changes
Ready for calls SOYO_Group	Allow a few seconds for the system to boot the new configuration and you are ready to make calls

Warning

Users are not allowed to change “protocol settings”, “phone settings”, or “audio settings” without proper guidance from the VoIP Service Providers or Carriers.

Configuration via Web Browser

First find out the IP address of the phone by pressing the **Local IP** button on the keypad of the phone. Then on a PC connected to the IP phone or at the same network segment of the IP phone, open the IE browser. Input the IP address of the phone, and then input password (default: 1234) of the phone into the following page. Now you will see following screen:

The screenshot shows the configuration page for a SOYO Group V1.41 IP phone. The browser window title is "SOYO_Group V1.41 - Microsoft Internet Explorer". The address bar shows "http://10.0.1.223/a". The page content is as follows:

network settings			
iptype	dhcp	ppp id	
local ip	10.0.1.223	subnet mask	255.0.0.0
dns	170.147.45.165	dns2	170.147.45.166
		router ip	10.0.0.1
		ppp pin	

protocol settings			
nat traversal	disable	nat addr	
phone number	9501111	account	sy00.9501111
register port	1720	signal port	1720
		rtp port	1722
		control port	1722

phone settings			
ring type	dtmf0		
forward number		fwd always	<input type="checkbox"/>
fwd poweroff	<input type="checkbox"/>	fwd busy	<input type="checkbox"/>
		fwd noanswer	<input type="checkbox"/>
		answer	30

other settings	
password	1234
upgrade addr	upgrade.soyo.com
sntp ip	210.59.157.10
use daylight	<input type="checkbox"/>
timezone	(GMT-08:00)Pacific Time(U.S. & Canada)

Buttons at the bottom: Save/Reboot, Address Book, Upgrade Firmware

Network Settings

iptype: Set how IP phone gets relevant network parameters by selecting corresponding item from drop down list.

static ip: Select this item to authorize users set IP address, subnet mask and router IP address of IP phone manually.

dhcp: Select this item to enable DHCP mode. With this system, your LAN or router automatically assigns all the required network parameters to any device connected to it when the device log on. So, if your LAN or router is configured to use DHCP addressing, the IP phone's LAN parameters will automatically be configured as soon as it is connected to the LAN or router and powered up.

pppoe: Select this item to enable PPPoE protocol. Some DSL providers require PPPoE setup. For more information, please contact your DSL provider.

modem: This function is not supported.

ppp id: With **pppoe** or **modem** selected in **iptype** drop down list, please enter the user name here.

ppp pin: With **pppoe** or **modem** selected in **iptype** drop down list, please enter the password here.

local ip: With **static ip** selected in **iptype** drop down list, please enter IP address of IP phone here.

subnet mask: With **static ip** selected in **iptype** drop down list, please enter subnet mask of IP phone here.

router ip: With **static ip** selected in **iptype** drop down list, please enter router IP address of IP phone here.

dns: With **static ip** selected in **iptype** drop down list, please enter IP address of DNS server here.

dns 2: With **static ip** selected in **iptype** drop down list, please enter IP address of backup DNS server here.

mac: MAC address is the physical address supplied by the Ethernet NIC. Centrality PA168S phone is shipped from the factory with a unique algorithm MAC address printed on the back of the base.

Protocol Settings

 **Note:** Please check with your VoIP service provider for the protocol settings. Changing the settings without proper guidance may result the IP phone not functioning.

nat traversal: NAT traversal method the IP phone uses.

nat addr: The NAT IP address required by certain type of traversal method.

phone number: Virtual IP phone number, the caller ID that will show up on the recipient's IP phone.

account: H.323 ID of the IP phone.

rtp port: RTP port is the port transferring and receiving voice flow using UDP. Please fill an even number between 1024 and 65535 into this field.

register port: Register port is the source port used by the IP phone to register to the gatekeeper. Please enter a number from 1024 through 65535 into this field.

signal port: Signal port is Q.931 port using TCP. It is arranged from 1024-65535.

control port: This port is H.245 port using TCP. Please enter a number from 1024 through 65535.

 **Note:** All above ports are the source ports that IP phone use to communicate with gatekeeper server. Please make sure the network firewall does not block them.

 **Note:** If there are many IP phones traversing in the NAT at the same time, each IP phone should be assigned with different port numbers.

Phone Settings

 **Note:** Please check with your VoIP service provider for the phone settings. Changing the settings without proper guidance may result the IP phone not functioning.

ring type: The ring tone the caller will hear when he calls this IP phone.

forward number: Enter the phone number that will receive forwarded calls into this field.

fwd always: Forward all calls by checking this box.

fwd noanswer: Forward calls without answering by checking this box.

fwd poweroff: Forward calls if power off by checking this box.

fwd busy: Forward calls if busy by checking this box.

answer: Enter a number from 0 through 60 to set the entries of the seconds before the phone forward the calls.

 **Note:** Some VoIP providers do not provide call forwarding function.

Other Settings

password: Set the password of the phone setting. (Default password is 1234).

upgrade addr: Enter IP address or domain name of the FTP server supplying the update programs. Check with your VoIP service provider for detail.

sntp ip: Enter IP address of the Internet time server here.

use daylight: Enable/disable daylight by checking/unchecking this box.

timezone: Select correct time zone of your city.

Save/Reboot

Click this button to save the configuration and restart the phone. Once the phone restarts successfully, the new configuration is effective.

 **Note:** After entering setup page, if **Save/Reboot** button is not clicked within 5 seconds, then when you click it again, the index page asking for pin will pop up again. Then please input the password again to enter the set page and then click **Save/Reboot** button to confirm the modification.

Address Book

Click this button to open the following speed dial settings page.

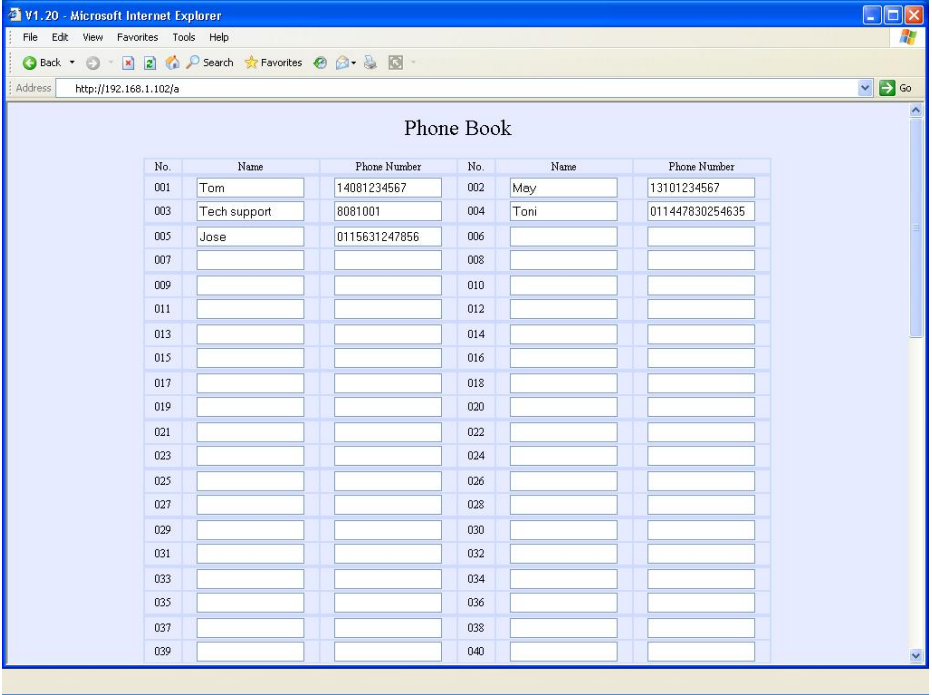



In this page, you can set and save the speed dial number by typing the name into the Name field and then entering the corresponding number following the name. For example, input “Tom” in Name field following 001, and then input the number, 14081234567 into Phone number field. So Tom’s number 14081234567 is saved in the phone book. Then please click **Save/Back** button at the bottom of the screen. Make sure click the **Save/Reboot** button to save them into the phone.

To use the speed dial feature, just use the keypad number keys to enter the speed dial number corresponding to your phone book entry, then press **speed dial** key to dial the number (i.e. dial 1 and press **speed dial**, the phone will call Tom’s number 14081234567).

Software Upgrading

Users can upgrade SOYO G668 IP phone to the latest software version by the following procedure: make sure the upgrade address has been entered into the setting page correctly, then from keypad dial “Hand-free Speaker”, input “12348” and then press “Local IP”, the software of SOYO G668 IP phone will be automatically upgraded to the latest version.

-  **Note:** The upgrading process may not start if you already have the latest version of the software.
-  **Note:** Software upgrading should be done when the phone has been successfully restarted and when the phone is in stable working conditions.

Troubleshooting

ISSUE	SOLUTION
<p>LCD reads: “wait logon...” or “logon failed”</p>	<p>Press Local IP button to find the IP address of your IP phone. If it shows 0.0.0.0, it means the Internet connection is down, please check the LAN cable and modem.</p> <p>If you are connecting the phone to a router, the IP address should normally be 192.168.xxx.xxx or 10.0.xxx.xxx. If it is not, you need to check the RJ-45 cable connection, and make sure the LAN port on your router is on and flashing</p> <p>If you are using the static IP, please check the network setting and make sure the static IP address, subnet mask, and gateway address are entered and set correctly.</p> <p>If you are using PPPoE, please check the network setting and make sure the ppp id and ppp pin is set correctly.</p> <p>Use web browser to visit the IP phone setting page. Consult with your VoIP service provider and compare the “phone numbert”, and “account” fields of the protocol settings area. Then click update button to reboot the phone.</p> <p>Possible causes:</p> <p>Firewall: When network firewall is enabled, it may cause logon failed. We suggest user open the UDP ports 1719 and 1115; TCP ports 1720, 80, and 8080. Also open UDP port above 5000.</p> <p>Modem compatibility: Some 2 in 1 modem/router device may have compatibility issue with VoIP devices. Please try to use a separate router.</p>
<p>I can not hear dial tone from the IP phone hand set</p>	<p>Make sure the phone cord is tightly connected to both handset and phone set.</p> <p>Check the volume level by pressing the volume+ button.</p>
<p>When I dial a phone number, I always hear fast busy tone.</p>	<p>When dial the phone number, make sure you follow the dialing rule of your VoIP service provider (i.e. 1-area code-888-1234 for US phone numbers). Please check with your VoIP service provider for detail.</p> <p>If you are using pre-paid VoIP service, please make sure you have enough balance on your account.</p>

SOYO G668 Ethernet IP Phone User Guide

When I dial a phone number, I can not hear any sound and the LCD always shows "Please Dial..."	Power off and power on the IP phone, and try again.
The voice quality is very poor during my conversation	There are very heavy internet activities in your network, such as uploading or downloading a huge amount of data from the Internet. Try to limit such activities to improve the quality.
I can make outbound calls, but I can not receive incoming calls	Refer to Configuration via Web Browser section and check the phone settings area, make sure the ring type and ring volume are set properly. If you are using a router or firewall, check with your VoIP provider to make sure it supports NAT traversal, and find out which port(s) is needed to allow incoming calls. Then follow the instruction in Appendix to enable the Port Forwarding.
LCD shows incorrect date and time	Refer to Configuration via Web Browser section and in "other setting" area: Check the sntp ip, or try another time server address. Check the timezone setting. Check the daylight saving option.

If you have further questions, please contact SOYO Group Inc. technical support department by:

Web: <http://phone.soyo.com>

Email: phone@soyousa.com

Tel: (909) 292-2560

Appendix: Port Forwarding

Note: Try port forwarding only when you have router or firewall in your network and your IP phone do not function correctly.

Applications running on TCP/IP open connections to other computers or Internet devices using something called ports. Sometimes your router or firewall will block certain communication ports between your network and outside traffic. These ports might be the ones needed by the IP phone to communicate with the Internet. You will need to configure your router or firewall so that certain port(s) in your network is accessible from the outside.

Different router manufactures have different process for port forwarding. So you will need to refer to your router manual for port forwarding configuration instruction.

Different VoIP protocols require different ports for communication. So you will need to consult your VoIP service provider to find out what port ranges should be opened, and forward these ports to the IP address of your IP phone.