



*iDrive*

**EDX**

**AC micro-inverters for small  
3-phase induction motors**

**100V series, 1-ph / 0.2 – 0.75kW (0.25 – 1HP)**

**200V series, 1-ph / 0.2 – 2.2kW (0.25 – 3HP)**

**200V series, 3-ph / 0.2 – 2.2kW (0.25 – 3HP)**

**400V series, 3-ph / 0.75 – 2.2kW (1 – 3HP)**

# Quick Start Guide

Always read the full instruction manual before using *iDrive*.

This quick start guide is to assist in installing and running the *iDrive* to verify that the *iDrive* and motor are working properly. Starting, stopping and speed control will be from the keypad. If your application requires external control or special system programming, consult the *iDrive* EDX instruction manual supplied with your inverter.

## Step 1 - Before applying power to your *iDrive*

Please refer to Chapter One (Preface) and Chapter Two (Safety Precautions) of the *iDrive* EDX instruction manual. Verify drive is installed in accordance with the procedures as described in Chapter Three (Environment and installation). If something is suspected of being abnormal, do not apply power to the drive until qualified personnel have corrected the situation. (Failure to do so could result in death or serious injury.)

- Check inverter and motor nameplates to determine that they have the same power and voltage ratings. Ensure that full load motor current does not exceed that of the inverter.
- With power OFF, remove the terminal covers to expose the motor and power terminals.
  - a. Verify that AC power is wired to L1(L), L2, and L3(N) .
  - b. Verify that motor leads are connected to T1, T2, and T3 .
  - c. If a brake module is necessary, please connect terminal voltage of the braking unit to P and N of the inverter. Never connect a resistor directly to *iDrive* terminals P and N.

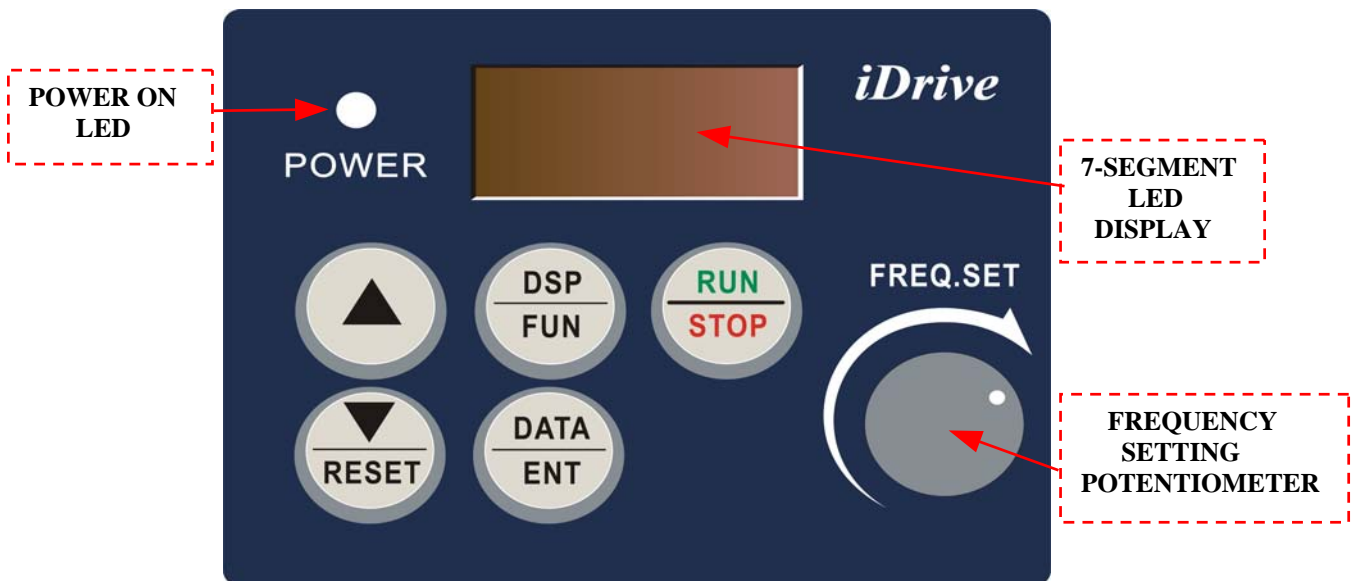

*iDrive* EDX keypad

## Step 2 - Apply power to your *iDrive*

Apply AC power to the drive and observe the keypad display. The 7-segment LED display should show power voltage (ie 220) for 3~5 seconds and then show the Frequency Command (Hz), factory set at 5.00. (Frequency Command shown on 7-segment display should be flashing, ie inverter output OFF.)

## Step 3 - Check low speed motor rotation direction without load from keypad.

(See keypad diagram on previous page)

- Press **RUN/STOP** key. 7-segment display will indicate 00.0 to 05.0. This number is the frequency output value. The display will now become solid (not blinking) because the inverter output is ON.
- Check the operating direction of the motor.  
IF the direction of the motor is incorrect:  
Press **RUN/STOP** key, turn off the AC power supply. When the power indicator LED is off, change over motor connections T1 and T2 for example.  
Apply the power again, and then check the motor direction by pressing **RUN/STOP** key.
- If rotation is correct press **RUN/STOP** key again.

## Step 4 - Check full speed at 50Hz / 60Hz

- Increase the frequency with  $\Delta, \nabla$  keys, press **DATA/ENT** to save this frequency.
- Set frequency to 50Hz / 60Hz according to the above.
- Press **RUN/STOP** key; check that the motor accelerates smoothly to full speed.
- Press **RUN/STOP** key; check that the motor decelerates smoothly to zero speed.

## Step 5 - Other settings

For other functions, please refer to *iDrive* EDX user manual.

Example:

Frequency Upper Limit (Hz).....	P. 4-9
Frequency Lower Limit (Hz).....	P. 4-9
Acceleration time (s).....	P. 4-10
Deceleration time (s).....	P. 4-10
Control mode (Vector, V/F).....	P. 4-10
Motor rated current (A).....	P. 4-13

## Step 6 - Vector Mode Settings

If *iDrive* is required to run in Vector Mode (A06 = 001), the motor parameters need to be set. The required data should be found on the motor rating plate. (Motor kW = 0.75 × HP)

The parameters to set for vector operation are:

Motor Rated Current (Amps) (b09)	See page 4-13
Motor Rated Voltage (Volts) (b10)	See page 4-13
Motor Rated Frequency (Hz) (b11)	See page 4-13
Motor Rated Power (KW) (b12)	See page 4-13
Motor Rated Speed (RPM) (b13)	See page 4-13

Additional Vector Mode Settings to adjust for optimum performance are:

Torque boost gain (b14)	See page 4-13
Slip compensation gain (b15)	See page 4-14
Low Frequency Voltage Compensation (b16)	See page 4-14

# *iDrive* EDX user manual

## Contents

Quick Start Guide .....	i
<b>Chapter 0 ~ Preface .....</b>	<b>0-1</b>
0.1 Preface .....	0-1
0.2 Product inspection .....	0-1
<b>Chapter 1 ~ Safety precautions.....</b>	<b>1-1</b>
1.1 Operating precautions.....	1-1
1.1.1 Before power up.....	1-1
1.1.2 During power up.....	1-2
1.1.3 Before operation .....	1-2
1.1.4 Leakage current! .....	1-2
1.1.5 During operation.....	1-3
1.1.6 Operating environment .....	1-3
<b>Chapter 2 ~ Part number description.....</b>	<b>2-1</b>
<b>Chapter 3 ~ Environment description and installation.....</b>	<b>3-1</b>
3.1 Environment .....	3-1
3.2 Environment precautions.....	3-6
3.3 Electrical Installation.....	3-7
3.3.1 Notes for wiring.....	3-7
3.3.2 MC, MCCB, fuse and cable specifications .....	3-9
3.3.3 Ancillary power equipment – supply side.....	3-10
3.3.4 Safety and EMC: Good wiring practice .....	3-11
3.3.5 Long motor cables: effects of volt drop and capacitance.....	3-13
3.3.6 Input side AC reactor.....	3-13
3.4 Specification .....	3-14
3.4.1 Product individual specification.....	3-15
3.4.2 General specifications.....	3-16
3.5 Connection diagram.....	3-18
3.6 Description of <i>iDrive</i> power and control terminals.....	3-19
3.7 <i>iDrive</i> dimensions .....	3-22
3.8 Multi- <i>iDrive</i> installation with regenerative loads.....	3-25

<b>Chapter 4 ~ Programming instructions &amp; Parameter list.....</b>	<b>4-1</b>
<b>4.1 Keypad description.....</b>	<b>4-1</b>
<b>4.1.1 Keypad layout.....</b>	<b>4-1</b>
<b>4.1.2 Local and Remote operating modes.....</b>	<b>4-1</b>
<b>4.1.3 Keypad navigation.....</b>	<b>4-2</b>
<b>4.2 Parameter function list.....</b>	<b>4-3</b>
<b>4.3 Parameter function description.....</b>	<b>4-9</b>
<b>Chapter 5 ~ Trouble shooting and maintenance.....</b>	<b>5-1</b>
<b>5.1 Fault indication and remedy.....</b>	<b>5-1</b>
<b>5.1.1 Fault/Error display and Diagnostics.....</b>	<b>5-1</b>
<b>5.1.2 Set up &amp; Interface Errors .....</b>	<b>5-4</b>
<b>5.1.3 Keypad operation error descriptions.....</b>	<b>5-5</b>
<b>5.2 General functional troubleshooting.....</b>	<b>5-6</b>
<b>5.3 <i>iDrive</i> Troubleshooting flowcharts .....</b>	<b>5-7</b>
<b>5.4 Routine and periodic checks.....</b>	<b>5-13</b>
<b>5.5 Maintenance and inspection.....</b>	<b>5-14</b>
<b>Chapter 6 ~ Options.....</b>	<b>6-1</b>
<b>6.1 Option cards.....</b>	<b>6-1</b>
<b>6.1.1 RS-485 option card.....</b>	<b>6-1</b>
<b>6.1.2 RS-232 option card.....</b>	<b>6-2</b>
<b>6.1.3 Program copy option card.....</b>	<b>6-3</b>
<b>6.1.4 Remote keypad .....</b>	<b>6-4</b>
<b>6.1.5 2 IN/1OUT expansion card .....</b>	<b>6-5</b>
<b>Appendix 1 <i>iDrive</i> EDX inverter parameter setting list.....</b>	<b>Appendix 1</b>

# Chapter 0 ~ Preface

## 0.1 Preface

To extend the performance of the product and ensure your safety, read this manual thoroughly before using the *iDrive*. Should there be any problem in using the product that can not be solved with the information provided in the manual, contact your nearest IMO distributor or the company from who you purchased the product from.

### Precautions

The *iDrive* is an electrical / electronic product. For your safety, there are symbols such as “**Danger**” and “**Caution**” in this manual to remind you to pay attention to safety instructions on carrying, installing, operating, and checking the *iDrive*. Be sure to follow the instructions carefully for safety.



Danger

Indicates a potential hazard that may cause death or serious personal injury to operator or other persons if misused



Caution

Indicates that the *iDrive* or a mechanical system might be damaged if misused



**Danger**

- Do not touch any circuit boards or internal parts until the charge indicator is extinguished after turning the power off.
- Do not connect any wires when the inverter is powered. Do not check parts and signals on circuit boards when the inverter is in operation.
- Do not disassemble the *iDrive* and modify internal wires, circuits and parts.
- Connect the PE (protective earth) terminals of the *iDrive* correctly. Always follow the advice given in this manual and conform to local / national regulations in force.



**Caution**

- Do not perform a high voltage insulation test on parts inside the inverter. High voltages can easily destroy the *iDrive*'s semiconductor components.
- Do not connect T1 (U), T2 (V), and T3 (W) terminals of the inverter to AC power source.
- CMOS ICs on the *iDrive*'s main board are sensitive to static electricity.  
Do not touch the main PC board even when power is off, or damage may occur.

## 0.2 Product Inspection

*iDrive* EDX inverters have all passed a full function test before delivery. Please check the following when you receive and unpack the inverter:

- The model and capacity of the inverter is the same as those specified on your order.
- Is there any damage caused during transportation? If so, do not apply power.  
Contact IMO distributor or authorised sales representative if any of the above are found to be incorrect..

# Chapter 1 ~ Safety Precautions

## 1.1 Operating Precautions

### 1.1.1 Before Power Up



#### Caution

The line voltage applied must comply with the *iDrive*'s specified input voltage.



#### Danger

Make sure the main circuit connections are correct. L1(L), L2, and L3(N) are power-input terminals and must not be confused with T1, T2 and T3. Otherwise, the *iDrive* might be damaged.



#### Caution

- To avoid dropping the *iDrive* do not hold by the front cover when carrying. Carry by supporting the main body moulding only as damage could occur if dropped.
- To avoid fire, do not install the *iDrive* on a flammable surface or in an enclosure manufactured from combustible material. If possible always install on metal surface.
- If several *iDrives* are placed in the same control panel, add extra heat dissipators to keep the temperature below 50°C to avoid overheating or fire.
- When removing or installing the remote keypad, turn the power off first, and operate the keypad following the instructions in this manual to avoid error.

#### NOTE

When connected as detailed in this manual, this product complies with IEC 61800-3, with built-in EMC filter for Unrestricted Distribution. Conformance should be tested before use in some environments.

### 1.1.2 During Power up

#### Danger

- The *iDrive* still has control power if the time of power loss is very short. When the power is re-applied, the inverter operation is controlled by parameter b31.
- The *iDrive* operation is controlled by parameters A00, b31, b32 and b33 and the status of any FWD/REV RUN switch. Please be sure to consider the following settings: -
  1. When A00=000, the inverter will not auto restart when power is re-applied.
  2. When A00=001 and operation switches FWD/REV RUN are OFF, the inverter will not auto restart when power is re-applied.
  3. When A00=001 and operation switch ON and b33=000, the inverter will auto restart when power is re-applied. Please turn OFF the run (start) switch to avoid potential damage to machine and injury to operator before the power is re-applied.
- When b33=000 (direct start on power up), please refer to the description of b33 to verify the safety of operator and machine.

### 1.1.3 Before operation

#### Caution

Make sure the model and capacity are the same as that set in parameter b89

### 1.1.4 Earth / ground leakage current

#### WARNING

**Warning! *iDrive* models with built-in EMC filter can give leakage current > 3.5mA.**

**ALWAYS ENSURE INVERTER IS CORRECTLY EARTHED / GROUNDED.**

**Follow instructions given in Section 3 of this manual in ALL installations.**

- **DO NOT** use *iDrive* EDX inverters on ungrounded (floating) power supplies.
- *iDrive* should be used in fixed installations only.

Operating *iDrive* EDX with Residual Current Device (RCD):

1. Leakage current may cause nuisance trip when RCD setting is <200mA
2. Only one inverter should be supplied from each RCD.



### 1.1.5 During operation



#### Danger

Do not connect or disconnect the motor while *iDrive* is operating otherwise the inverter and/or the disconnecting device may be damaged by the high level of switch-off current.



#### Danger

- To avoid electric shock, do not remove the front cover when power is on.  
After a power-loss (under-volt) trip occurs, the motor will restart automatically when power is restored if auto-restart function is set. In this case, care must be taken while working with the machine.
- Note: External Emergency stop must mechanically open and un-latch the power supply to the *iDrive* without any chance of re-closing until required. It is not permitted to rely upon software control for an emergency stop.



#### Caution

- Do not touch heat-generating components such as heat sink and brake resistor.
- The inverter can operate the motor from low speeds to very high speeds.  
Verify the allowable speed ranges of the motor and the load before operation.
- Note the settings related to the braking unit.
- Do not check signals on circuit PCB while the inverter is running.



#### Caution

Allow a minimum of 5 minutes for *iDrive* to discharge after power down before attempting to disassemble or checking the components within the drive.

### 1.1.6 Operating environment



#### Caution

*iDrive* can be used in a non-condensing atmosphere in temperature range from  $-10^{\circ}\text{C}$  to  $+50^{\circ}\text{C}$  and relative humidity of 95%, but the environment should be free from corrosive or explosive gasses, condensation or conductive dust.

## Chapter 2 ~ Part numbering description

*iDrive* product rating label (example)

	<b>CAUTION</b>	Do not inspect components unless the lamp is off See manual for correct installation and operation	
	<b>Model:</b> EDX-040-21-E <b>INPUT:</b> AC 1 phase 50 / 60Hz <b>OUTPUT:</b> AC 3 phases 0 – 200Hz	<b>Motor Rating:</b> 0.5HP / 0.4KW <b>VOLTAGE:</b> 200 – 240V (+10%, -15%) <b>VOLTAGE:</b> 0 - V <sub>IN</sub>	<b>I<sub>RMS</sub> :</b> 5.4A <b>I<sub>RMS</sub> :</b> 3.1A
IP20 / UL Open Type (rated -10°C to 50°C Ambient)		<b>IMO Precision Controls Ltd</b>	
<b>WARNING: THIS PRODUCT MUST BE EARTHED IN ACCORDANCE WITH THE iDRIVE V4 (OR LATER) INSTRUCTION MANUAL AND LOCAL/NATIONAL WIRING CODES IN FORCE WHERE THIS iDRIVE IS TO BE INSTALLED.</b>			

*iDrive* part numbers – key to product rating label

EDX	-	040	-	2	1	-	E	-
<b>Series:</b>		<b>Nominal motor capacity:</b>		<b>Input voltage:</b>	<b>Input phases</b>		<b>EMC filter :</b>	<b>Enclosure</b>
		020: 0.18kW / 0.25 HP		1:100V	1: 1- phase		E: Integrated Filter	N4S: IP65 /NEMA4 + water and dust-proof isolator / switch / potentiometer
		040: 0.37kW / 0.5 HP		2:230V	3: 3-phase		Blank: No Filter	
		075: 0.75kW / 1.0 HP		4: 400V				N4: IP65 No switches etc
		150: 1.5kW / 2.0 HP						
		220: 2.2kW / 3.0 HP						Blank: IP20

## Chapter 3 Environment description and installation

### 3.1 Environment

The environment will directly effect the operation and the life of the *iDrive*.

Always install the *iDrive* in an environment that complies with the following conditions:

- Ambient temperature:  $-10^{\circ}\text{C} \sim +50^{\circ}\text{C}$
- Avoid exposure to rain or moisture.
- Avoid smoke and salinity.
- Avoid dust and conductive particles.
- Avoid sources of strong electromagnetic interference
- Avoid vibration. Use vibration-proof mounts if the situation can not be avoided.
- If several inverters are placed in the same control panel, additional cooling must be used to keep the temperature below  $50^{\circ}\text{C}$ .
- Avoid direct sunlight.
- Avoid erosive liquid and gas.
- Keep away from radiation and flammable materials.

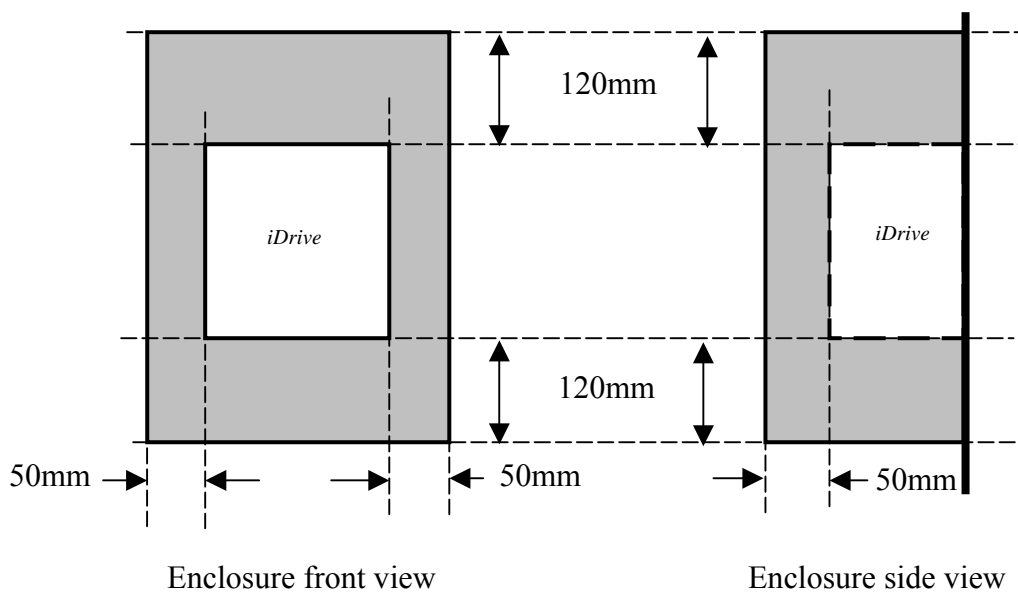
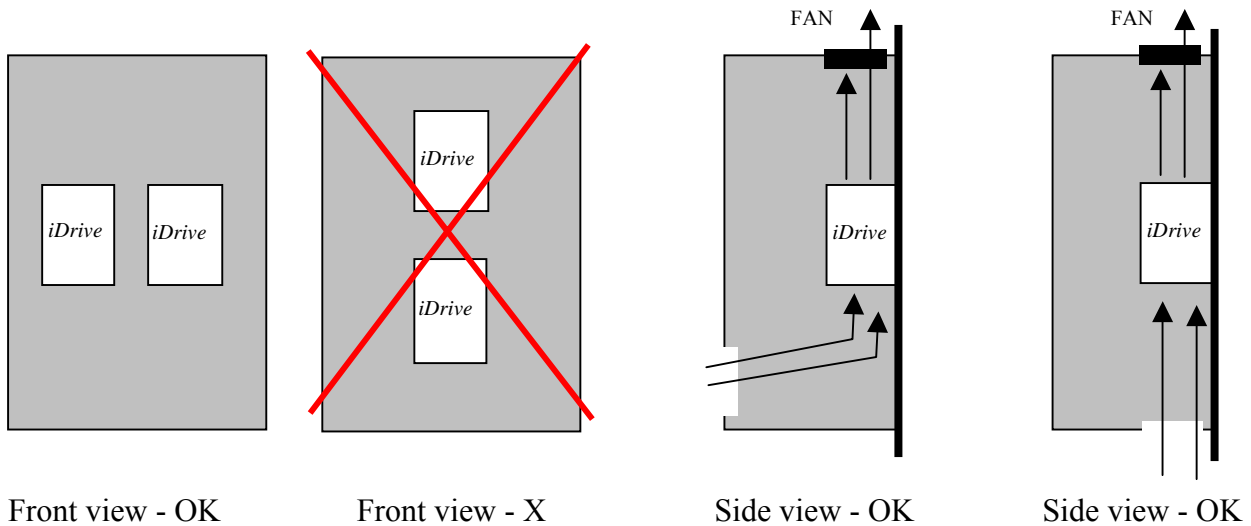

- The chassis of this model has DIN rail clip device to use when rail mounting.

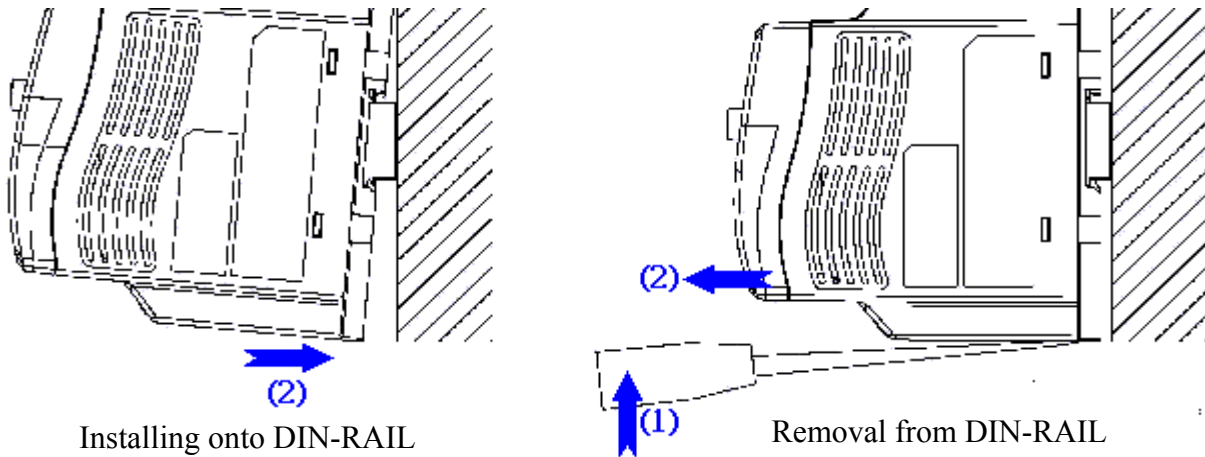

- All *iDrive* IP20 models can be installed side-by-side when temperature is below 50°C.

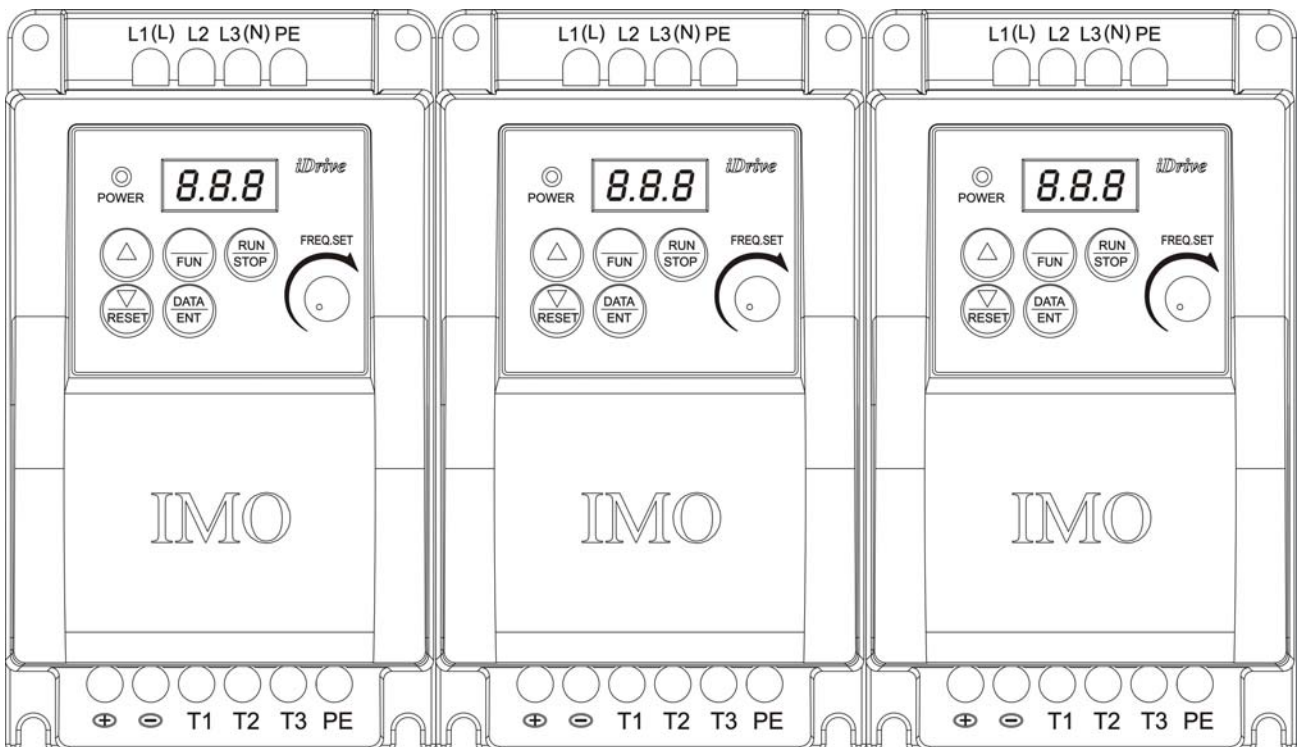

• *iDrive* EDX- 040-21 / 075-21; 040-11 / 075-11-N4S (IP65) type installation:

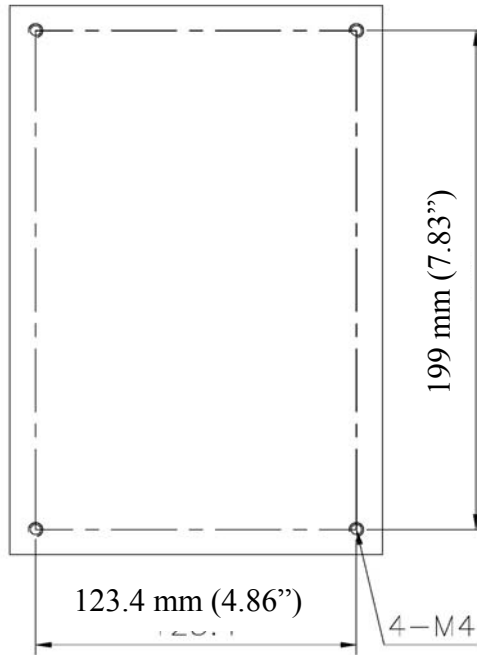
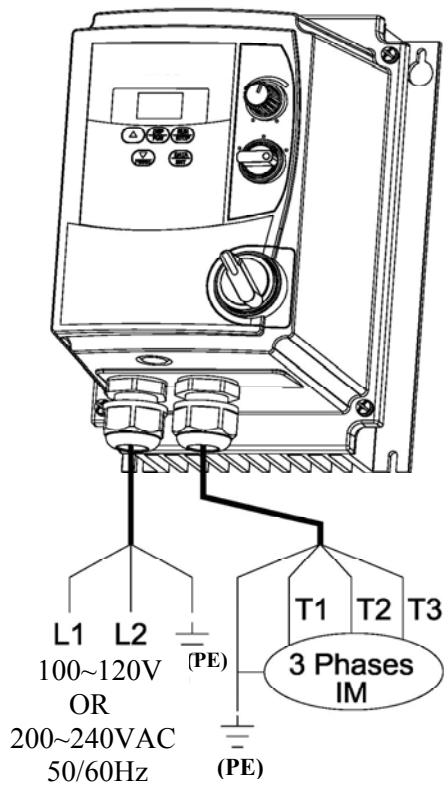

**NOTES A :**

1. Isolating switch, REV-0-FWD switch and potentiometer are only for EDX-#####- N4S models
2. Power supply cable : 600V AC rated PVC
3. Motor cable : 600V AC rated PVC / (screened or armoured)/PVC
4. Maximum torque on terminal screws :
  - (1). Power/motor cable (plug in) terminal : 5kg-cm(4.34 in-lb)
  - (2). Remote control wire : 4kg-cm (3.47 in-lb)
  - (3). Outer cover (M4) : 6kg-cm (5.20 in-lb)

**NOTES B:**

- (1). Input power : single-phase (L1,L2, PE) ensuring supply is 100~120 or 200~240VAC according to model type.
- (2). Motor output: three-phase (T1,T2,T3, PE).  
**Caution: Do not start or stop the motor by switching input power**
  - For EV-#####-N4S type :  
 Ensure that the REV-0-FWD switch is set at '0' position so that the *iDrive* has no run signal at power-on otherwise injury may result.

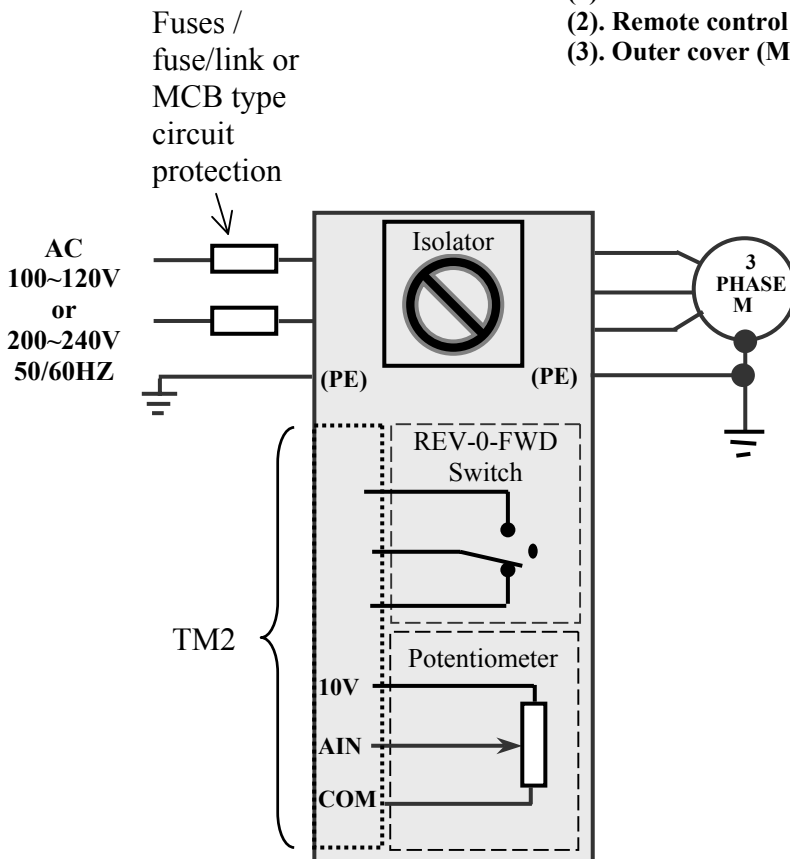

• EDX-###-##-N4S installation :

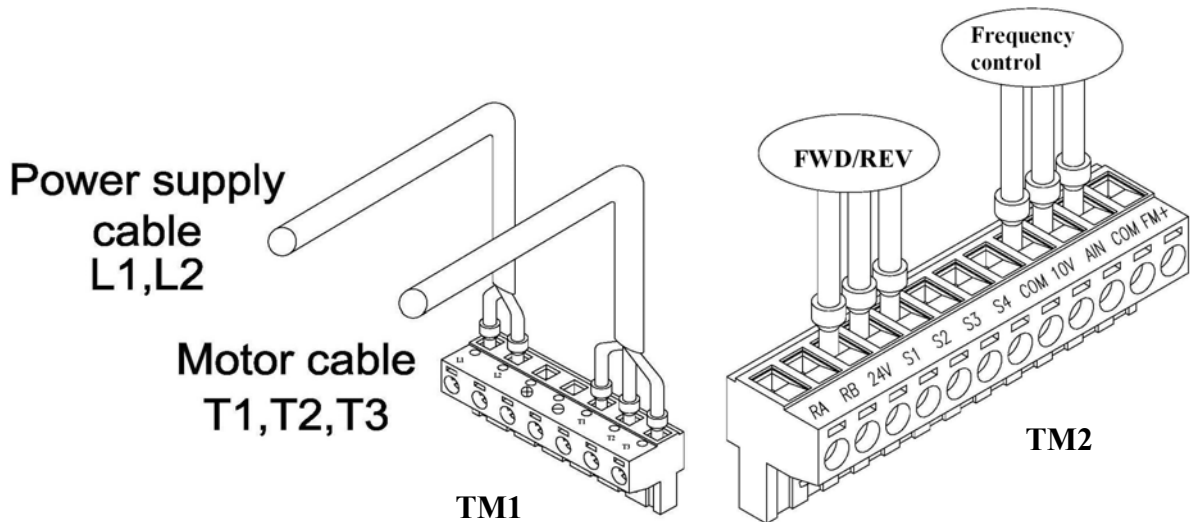
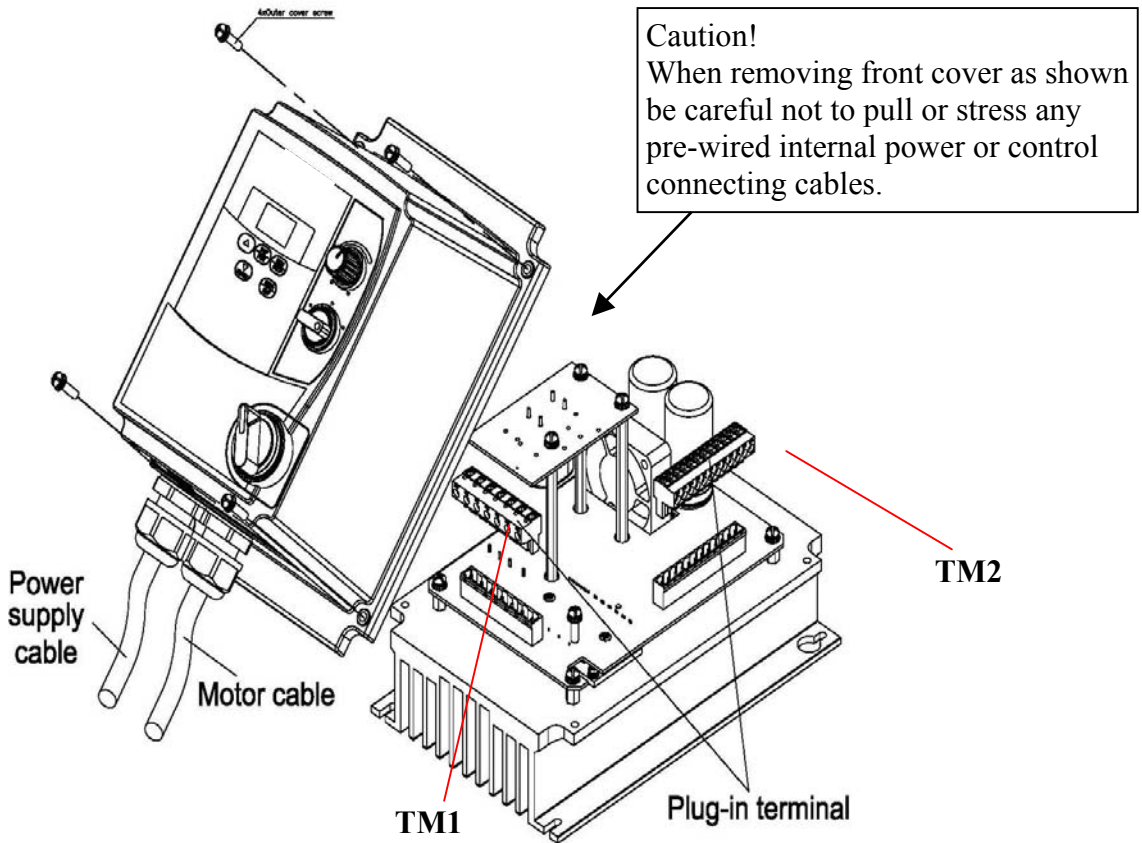

• EDX-###-##-N4 installation :

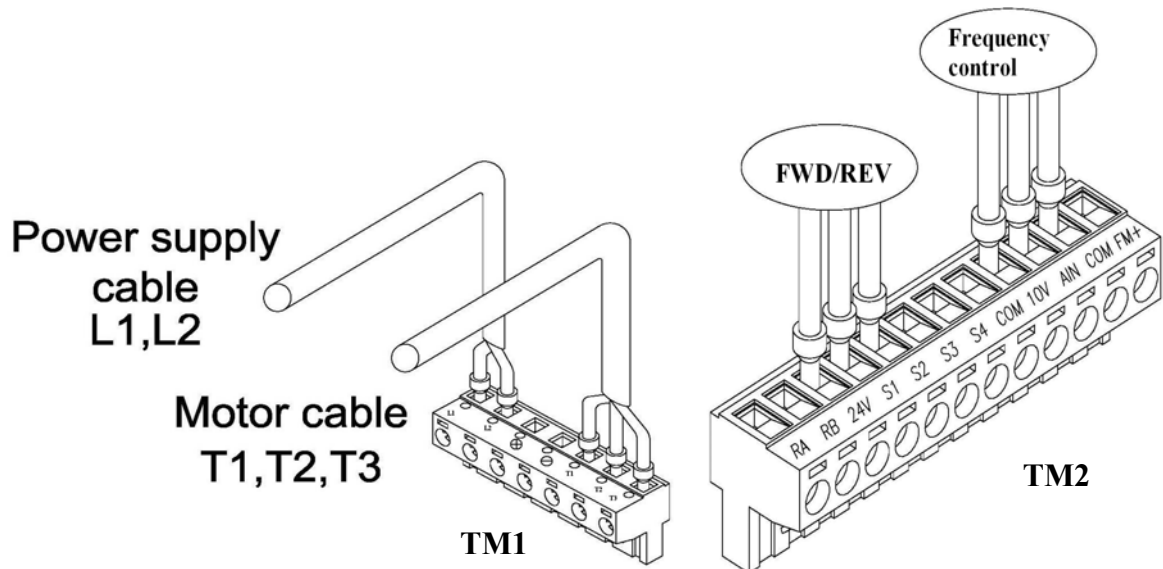
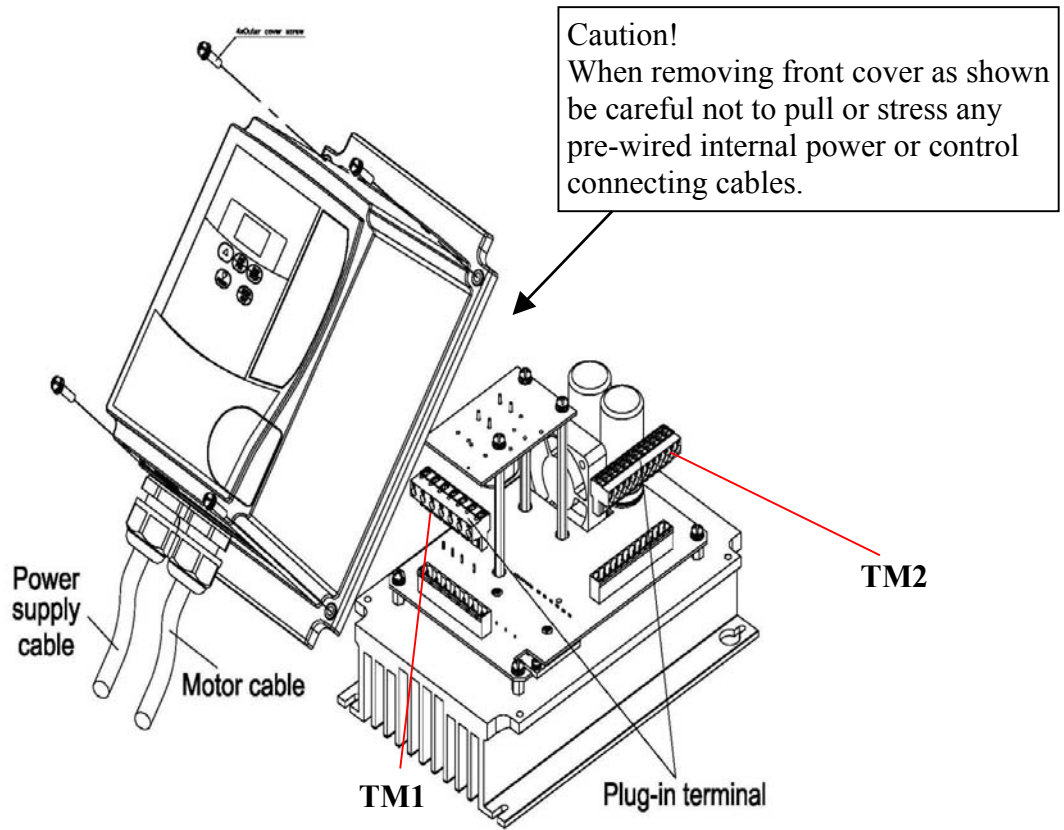



### 3.2 Environmental precautions

Do not use the inverter in an environment with the following conditions:

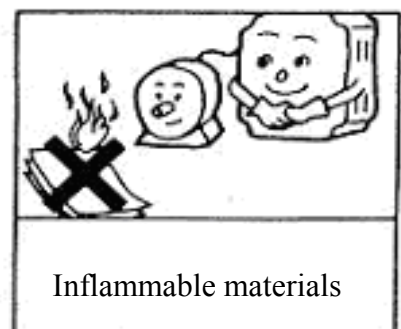
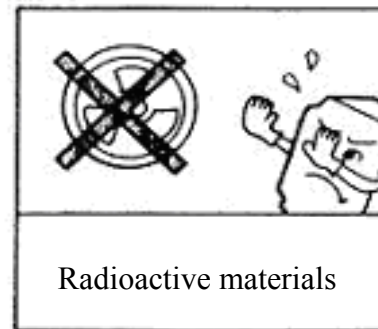
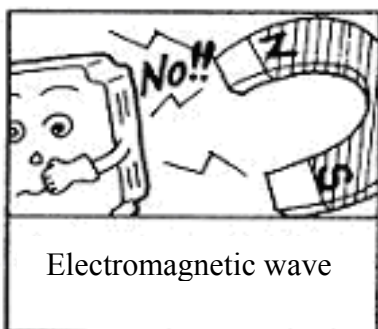
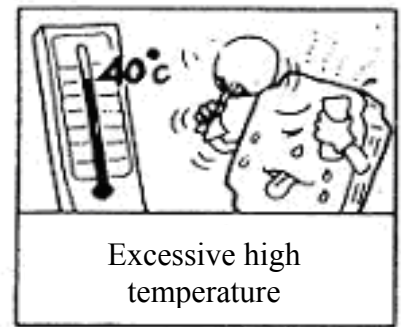
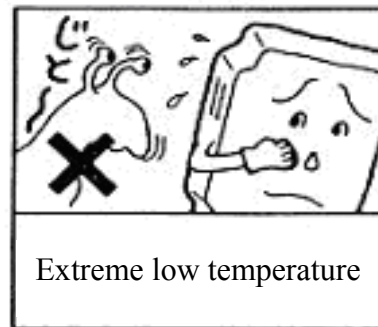
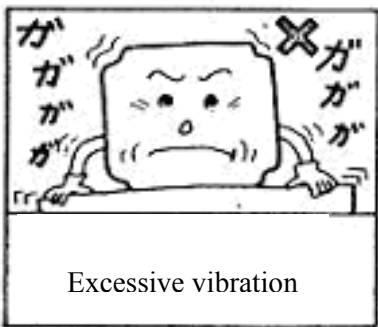
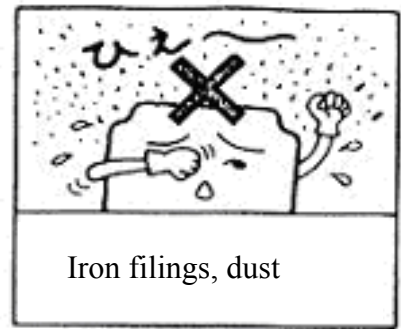
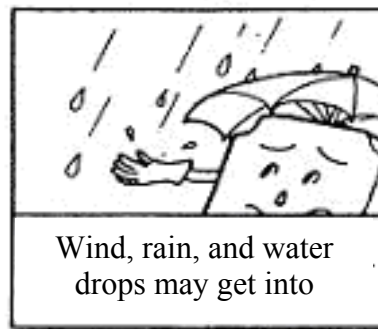
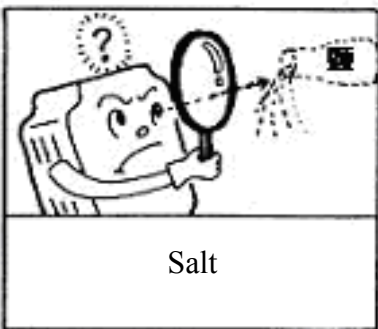
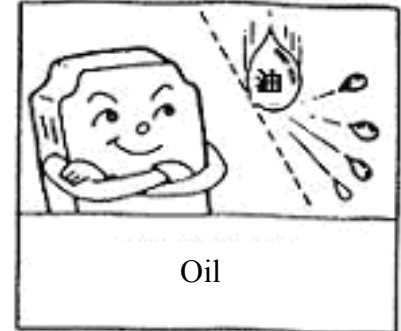
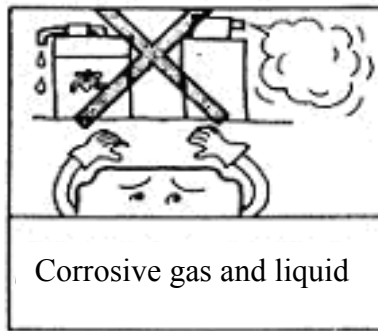
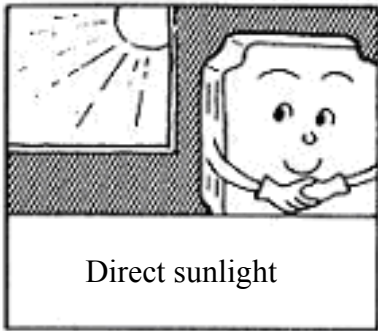



### 3.3 Electrical Installation

#### 3.3.1 Notes for wiring

##### A. Screwdriver torque:

Connect cables and tighten to the torques listed below.

Tightening torque				
Horsepower	KW	Power source	Nominal tightening torque for TM1 terminals	
0.25/0.5/1	0.2/0.4/0.75	100-120V	0.74/0.1	8.66/10
0.25/0.5/1	0.2/0.4/0.75	200-240V	(lbs-ft / Kg-m)	(lbs-in / Kg-cm)
2/3	1.5/2.2	200-240V	1.286/0.18	15.97/18
1/2/3	0.75/1.5/2.2	380-480V	(lbs-ft / Kg-m)	(lbs-in / Kg-cm)

##### B. Power cables (connected to TM1):

Power cables are connected to L1(L), L2, L3 (N), T1, T2, T3, P and N. Choose cable in accordance with the following criteria:

- (1) Use cable with copper cores only. Select cable with insulation diameter based on working conditions at 221°F / 105°C.
- (2) For nominal voltage ratings, use cable rated at minimum 300V for 240Vac *iDrive* and 600V rated cable for 480Vac *iDrive*.

##### C. Control cables (connected to TM2):

Control cables are connected to TM2 control terminals. Choose cable in accordance with the following criteria:

- (1) Use cable with copper cores only. Select cable with insulation diameter based on working conditions at 221°F / 105°C.
- (2) For nominal voltage ratings, use cable rated at minimum 300V for 240Vac *iDrive* and 600V rated cable for 480Vac *iDrive*.
- (3) To avoid noise interference, do not run control cables in the same conduit or trunking as power cables. Where possible use screened / shielded control cables to minimise electromagnetic interference. To avoid ground loops always earth the shield at one end only.

##### D. Nominal electrical specifications of terminal block TM1:

KW	HP	Power source	Volts	Amps
0.2 / 0.4 / 0.75	0.25 / 0.5 / 1	100-120V	600	15
0.2 / 0.4 / 0.75	0.25 / 0.5 / 1	200-240V		
1.5 / 2.2	2 / 3	200-240V	600	40
0.75 / 1.5 / 2.2	1 / 2 / 3	380-480V		

## E. Fuse types

Drive input fuses are necessary to disconnect the drive from the power supply in the event of component failure in the drive's power input circuit. The *iDrive*'s electronic protection circuitry is designed to clear output short circuits and ground faults without blowing the input fuses. The table below shows the *iDrive* EDX input fuse ratings.

To protect the *iDrive* most effectively, use fuses with quick-blow characteristics (semi-conductor fuses).

**It is the responsibility of the user/installer to ensure that the correct fuse protection (or other) is applied.**

### RK5, CC/T type fuses for *iDrive* EDX

#### 110V input models (1-phase)

EDX-	HP	KW	KVA	100% CONT Output AMPS (A)	Max.RK5 FUSE Rating(A)	Max.CC or T FUSE Rating(A)
020-11	0.25	0.2	0.53	1.7	10	20
040-11	0.5	0.4	0.88	3.1	15	30
075-11	1	0.75	1.6	4.2	20	40

#### 220V input models (1-phase)

EDX-	HP	KW	KVA	100% CONT Output AMPS (A)	Max.RK5 FUSE Rating(A)	Max.CC or T FUSE Rating(A)
020-21	0.25	0.2	0.53	1.7	8	15
040-21	0.5	0.4	0.88	3.1	10	20
075-21	1	0.75	1.6	4.2	15	30
150-21	2	1.5	2.9	7.5	20	40
220-21	3	2.2	4.0	10.5	25	50

#### 220V input models (3-phase)

EDX-	HP	KW	KVA	100% CONT Output AMPS (A)	Max.RK5 FUSE Rating(A)	Max.CC or T FUSE Rating(A)
020-23	0.25	0.2	0.53	1.7	5	8
040-23	0.5	0.4	0.88	3.1	8	10
075-23	1	0.75	1.6	4.2	12	15
150-23	2	1.5	2.9	7.5	15	20
220-23	3	2.2	4.0	10.5	20	30

#### 440V input models (3-phase)

EDX--	HP	KW	KVA	100% CONT Output AMPS (A)	Max.RK5 FUSE Rating(A)	Max.CC or T FUSE Rating(A)
075-43	1	0.75	1.7	2.3	6	10
150-43	2	1.5	2.9	3.8	10	15
220-43	3	2.2	4.0	5.2	10	20

#### UL class fuses overload characteristics.

RK5 - type has a time delay characteristic

T-type is quick-blow

CC – type have both types of characteristic

\*Fuse ratings are based upon 250V fuses for 120V inverters, and 300V fuses for 240V inverters, and 600V for 480V inverters.

**3.3.2 MC, MCCB, Fuse and cable specifications.****MCCB/ MC/ Fuse**

- IMO warranty will not apply under the following condition.
  - (1) MCCB or fuse is not installed or incorrectly installed or installed with over capacity, which has resulted in *iDrive* failure.
  - (2) MC or capacitor or surge absorber is connected in series between inverter and motor.

<i>iDrive</i> EDX model	###-11/21/43				###-43(-E)
	020-11/040-11 040-11 040-21-E	075-21-E 075-23	150-21-E 220-21-E	150-23 220-23	075/150/220
Fuse	10A 300Vac	16A 300Vac		20A 300Vac	16A/600Vac
MCCB	10A	20A	32A		16A
MC (from IMO)	MC14-S	MC18-S	MC32-S		MC18-S
Power Input/Output cables (c.s.a.)	2.5mm <sup>2</sup> / (13 AWG) Terminal screw M4		4 mm <sup>2</sup> / (11AWG) Terminal screw M4		2.5mm <sup>2</sup> / (13 AWG) Terminal screw M4
Earth/ground cables PE terminal (c.s.a.)	4 mm <sup>2</sup> / (11AWG) Terminal screw M4		See Note 1 Below	4 mm <sup>2</sup> (14AWG) Terminal screw M4	
Control terminals (TM2)	Cable dimension 0.75mm <sup>2</sup> (18AWG) Terminal screw M3				

## Notes

1. To comply with BS7671 requirements the *iDrive* must be earthed by a conductor(s) of minimum 4 mm<sup>2</sup> c.s.a. with additional mechanical protection. Therefore the *iDrive* must be installed in a steel enclosure and wired according to the diagram on page 3-11.
2. Use a single fuse in the live line for 1-phase input *iDrive* models where supply is L+N. Where L+L supply is to be used, each line must be fused. For 3-phase input models, each L1(L)/L2/L3(N) phase must be fused or protected by MCCB.
3. A suitable three-phase ‘squirrel cage’ induction motor must be used with *iDrive*.
4. If an *iDrive* is to operate more than one motor in parallel, the total operating current should be less than or equal to the *iDrive*'s rated output current. A suitable thermistor should be installed in each motor to protect from winding over-heat.
5. Do not install a capacitor, LC, or RC network between the *iDrive* and the motor.

### 3.3.3 Ancillary power equipment – supply side:

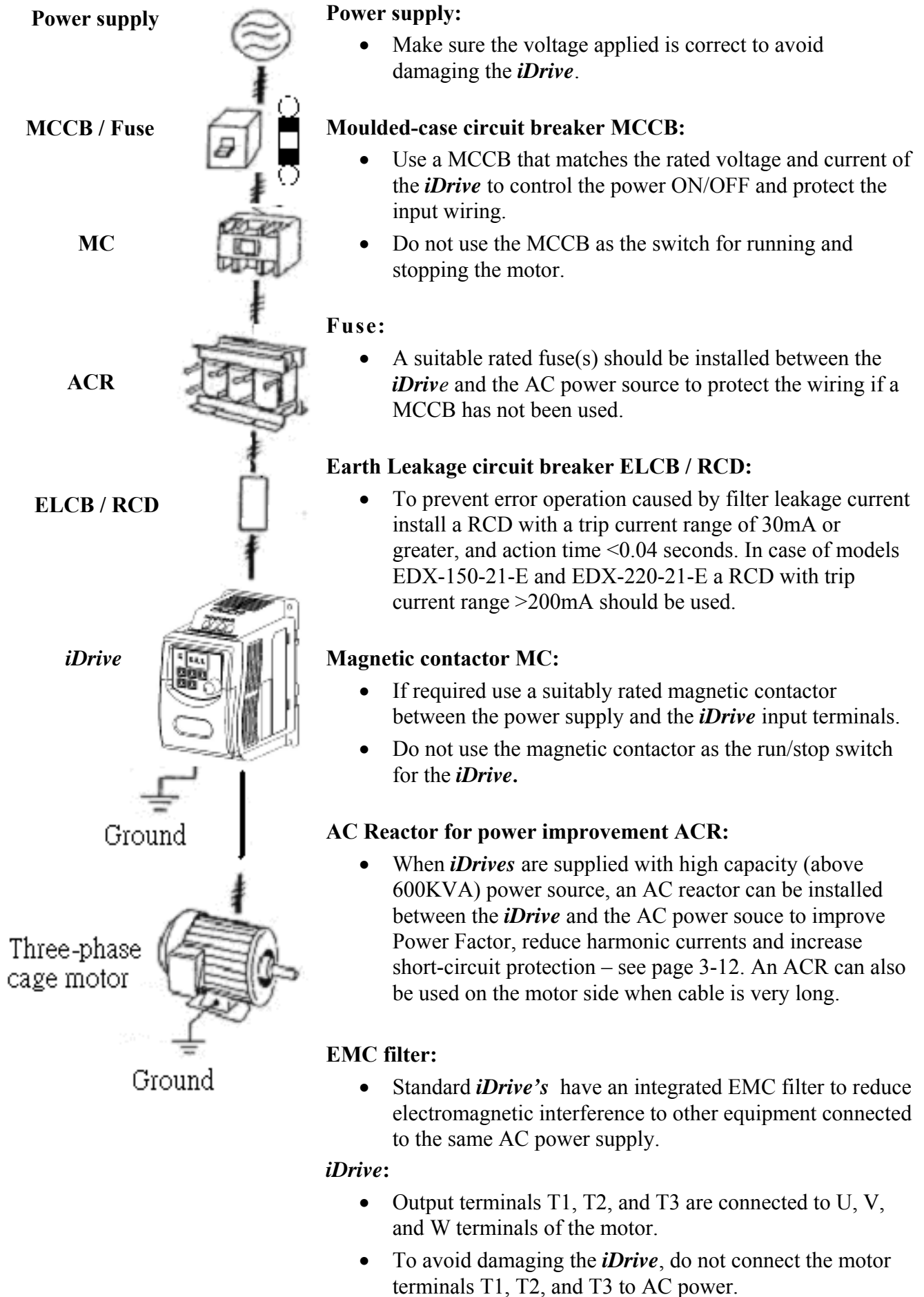

3.3.4 Safety and EMC: Good wiring practice IP20 models

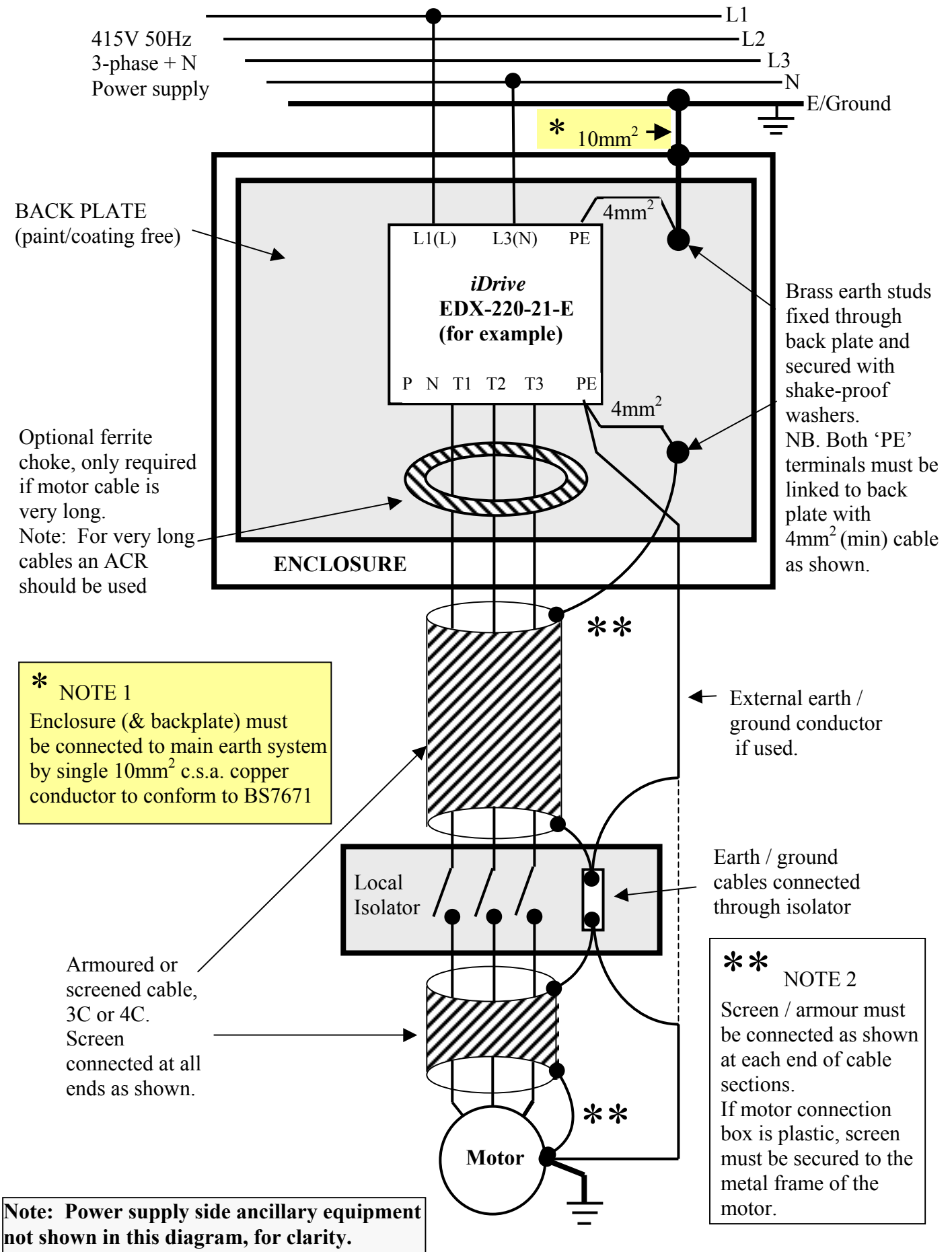

- Further good EMC practice IP20 models

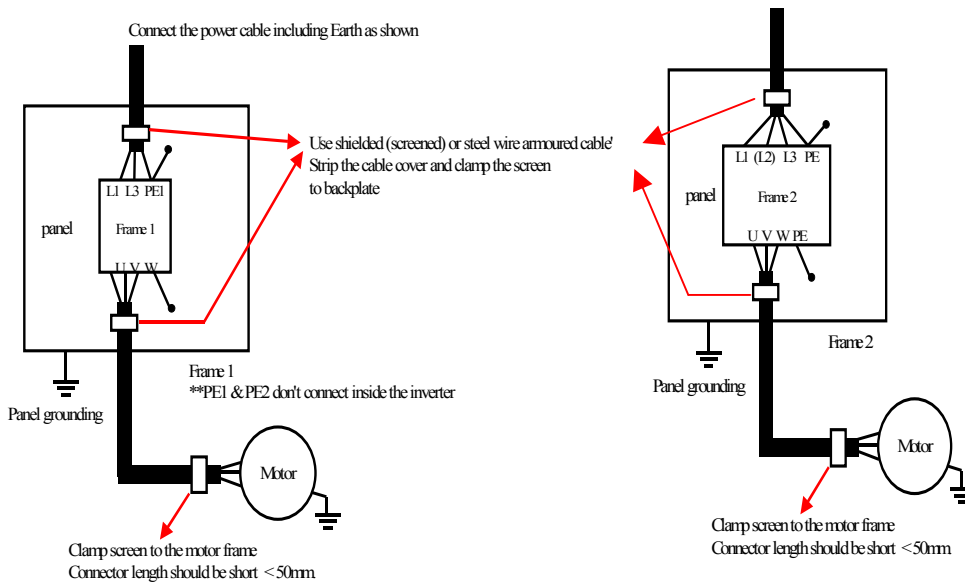

- A ferrite choke in the output of the main circuit can suppress conducted emissions. To limit the effects of radiated emissions unscreened motor cables should be put in an earthed metal conduit. Do not run control cables inside conduit or within 30 cm of the motor cables.
- If control/signal cables must cross over motor cables, ensure that they do so at right angles (90°).
- The supply and output (PE) terminals should be connected to ground to increase noise immunity of the integrated EMC filter.
- To prevent RF interference resulting in *iDrive* operation error, control circuit wiring should be shielded and twisted. Please refer to following diagram, connect shielded wire to ground terminal at one end only. The wiring distance should be less than 50m.

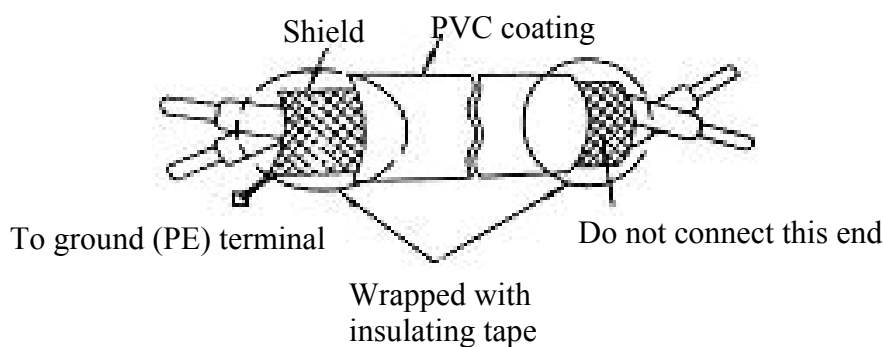

- Earth / ground wiring should be made as short and thick as possible. Copper braided tape is better than cable for this application, but not always practical.
- Do not ‘daisy-chain’ the earth / ground of the inverter to other equipment. Connect the (PE) terminal to a centralized main earth / ground point and ‘star’ connect all other equipment ground wires to this point.
- Do not make a loop when several inverters share a common ground point.

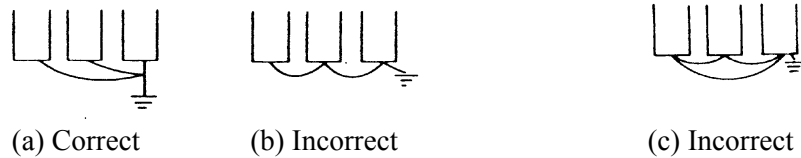

To ensure maximum safety, use correct wire size for the main power circuit and control circuit according to the required wiring regulations.

On completion, check that the wiring is correct and terminal screws are secured.

### 3.3.5 Long motor cables: effects of volt drop and capacitance

When the cable between the *iDrive* and the motor is too long, the effect of volt drop along the cable and cable capacitance must be considered. For very long cables it is sometimes necessary to use *iDrive* one frame size higher than motor power rating.

Phase-to-phase voltage drop ( $V_d$ )

$$V_d = \sqrt{3} \times \text{resistance of wire } (\Omega/\text{km}) \times \text{length of line (mts)} \times \text{current} \times 10^{-3}$$

To prevent RF problems and excessive high frequency ground leakage currents the *iDrive* carrier frequency (function **b86**) should be adjusted based on the length of the motor cable, for example:

Motor cable length	< 25m	< 50m	< 100m	> 100m
Carrier frequency (b86)	< 16kHz	< 12kHz	< 8kHz	< 5kHz

### 3.3.6 Input side AC reactor

An AC input reactor can be installed to reduce the harmonic content of the *iDrive* input current. If the harmonic distortion is reduced, the RMS input current is also reduced.

An AC reactor can also be installed on the output side of *iDrive* when the motor cable is excessively long and can counter the effect of cable capacitance and nuisance tripping. Contact IMO for details.

#### Input reactor specifications

<i>iDrive</i> model		Line input side AC inductance (typical)	
		Current (A)	Inductance (mH)
EDX -	040-21-#	5.0	2.1
	075-21-#	5.0	2.1
	150-21-#	19.0	1.1
	220-21-#	25.0	0.71
	075-43-#	2.5	8.4
	150-43-#	5.0	4.2
	220-43-#	7.5	3.6

**IP65 / NEMA4 - EMC good practice guide EDX-150-21, 220-21, 075-43, 150-43, 220-43**

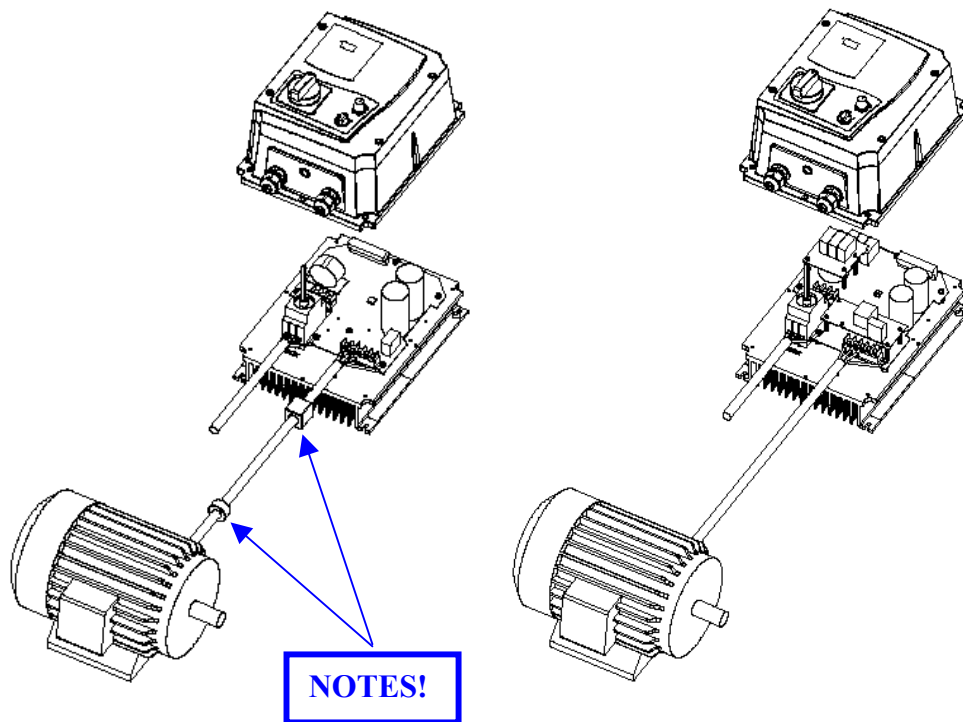

**NOTES:**

1) For **EDX-150-21-E – N4S** and **EDX-220-21-E-N4S** models, additional items will be found inside the outer packaging including 2pc of EMC conformed waterproof (IP65) ferrite core.

2) If application requires meeting published EMC performance class, you must fit the ferrite cores onto the motor cable outside the plastic sheath as shown in the above diagram. The quadrilateral type ferrite core should be fitted as close as possible to inverter output terminals T1, T2, T3, and the circular type ferrite core should be fitted close to the motor.

Please also note that the length of the motor cable **CANNOT** exceed 5 metres if the declared EMC performance is to be met.



### 3.4 Specification

#### 3.4.1 Product individual specification

<i>iDrive</i>	100V model			200V model									
	EDX-□□□-11			EDX-□□□-21 (-E)					EDX-□□□-23				
	020	040	075	020	040	075	150	220	020	040	075	150	220
Horsepower (HP)	0.25	0.5	1	0.25	0.5	1	2	3	0.25	0.5	1	2	3
Suitable motor capacity (kW)	0.2	0.4	0.75	0.2	0.4	0.75	1.5	2.2	0.2	0.4	0.75	1.50	2.2
Rated output current ( $A_{RMS}$ )	1.7	3.1	4.2	1.7	3.1	4.2	7.5	10.5	1.7	3.1	4.2	7.5	10.5
Rated capacity (kVA)	0.53	0.88	1.60	0.53	0.88	1.60	2.90	4.00	0.53	0.88	1.60	2.90	4.00
Input voltage range (V)	1-phase 100~120V+10%, -15% (50/60Hz)			1-phase 200~240V+10%, -15% (50/60Hz)					3-phase 200~240V+10%, -15% (50/60Hz)				
Output voltage range (V)	3-phase 0~240V												
Input current ( $A_{RMS}$ )	7.1	12.2	17.9	4.3	5.4	10.4	15.5	21	3.0	4.0	6.4	9.4	12.2
Net weight (Kg)	0.62	0.68	0.72	0.71	0.73	0.73	1.25	1.3	0.61	0.61	0.66	0.95	1
Allowable momentary power loss time (S)	1.0	1.0	1.0	1.0	1.0	1.0	2.0	2.0	1.0	1.0	1.0	2.0	2.0
Enclosure	IP20												

<i>iDrive</i>	400V model		
	EDX-□□□-43 (-E)		
	075	150	220
Horsepower (HP)	1	2	3
Suitable motor capacity (kW)	0.75	1.50	2.2
Rated output current ( $A_{RMS}$ )	2.3	3.8	5.2
Rated capacity (kVA)	1.7	2.9	4.0
Input voltage range (V)	3-phase 380~480V+10%, -15% (50/60Hz)		
Output voltage range (V)	3-phase 0~480V		
Input current ( $A_{RMS}$ )	3.0	4.8	6.6
Net weight (Kg)	1.68	1.70	1.73
Allowable momentary power loss time (S)	1.0	2.0	2.0
Enclosure	IP20		

Standard Models
-----------------

Non-Standard Models
---------------------

## 3.4.2 General Specifications

Frequency control	Output Frequency range	0~200Hz
	Starting torque	100% / 3Hz (Vector mode)
	Speed Control Range	20:1 (Vector mode)
	Speed Control accuracy	±0.5% (Vector mode)
	Setting resolution ※1	Digital: 0.1Hz(0~99.9Hz)/1Hz(100~200Hz); analog: 0.06Hz/ 60Hz
	Keypad setting	Set directly with ▲ ▼ keys or the potentiometer VR on the keypad
	Display / Indication	7 segment*3. Displays frequency / DC voltage / output voltage / output current / inverter parameters / alarm log /software version / PID feedback control
	External signal setting	<ul style="list-style-type: none"> <li>•External variable resistor / 0-10V/ 4-20mA</li> <li>•Performs up/down control (Motorized Pot.) with multi-function programmable inputs on the terminal base.</li> </ul>
Frequency limit functions	Possible to set Upper and Lower frequency limits, and two-stage skip-frequencies.	
General control	Carrier frequency	4~16KHz (default 10KHz, above 10KHz with de-rating)
	V/F pattern	Select 6 fixed patterns 50Hz/60Hz or 1 user programmable pattern
	Acc/dec control	Two independent sets of accel / decel ramps (0.1~999s)
	Multi-func. analog O/P	6 functions (refer to b53 description)
	Multi-func. digital I/P's	19 functions (refer to b35~b38 description)
	Multi-funct. relay O/P	16 functions (refer to b55 description)
	DO (relay output)	1* Relay output as standard SPST.---- selectable as multi-function output. 1* optional external multi-function output (open-collector transistor 24V, 600mA)
	DI (digital inputs)	Selectable NPN/PNP: 4 inputs (S1~S4) as standard; 2 extra inputs (S5~S6) available on option card.
	AI (analog input)	Set speed command and PID feedback signal (speed, PID, 4~20mA / 0~10V)
	Other functions	Instantaneous power loss restart, Speed search, auto-restart, DC brake, torque boost, 2 / 3 wire control and PID control.
Environment	Communication control	<ul style="list-style-type: none"> <li>•RS485 Option card: Modbus RTU/ASCII modes, 4800~38400 bps, max. 254 stations</li> <li>•PC/PDA software</li> </ul>
	Operation temperature	-10~50°C (inside enclosure) IP20 ; -10~40□ IP65
	Storage temperature	-20~60°C
	Humidity	0 – 95% RH (non condensing)
	Vibration immunity	1G (9.8m/s <sup>2</sup> )
	EMC ※2	Internal EMC filter: First Environment, Restricted Distribution. External EMC filter: First Environment, Unrestricted Distribution. In accordance with EN61800-3
	LVD	Conforming to EN50178
	Enclosure	IP20
	Safety Class	UL508C

Protective Functions	Over load protection	Inverter rated current 150%/1min
	International conformity	UL/cUL/CE
	Over-voltage trip	200V Class: DC voltage >400V. 400V Class: DC voltage >800V
	Under-voltage trip	200V Class: DC voltage <190V. 400 Class: DC voltage <380V
	Instantaneous power-loss restart	Set to enable or disable
	Stall prevention	ACC/DEC/ Operation stall prevention and stall prevention level.
	Output terminal short circuit	Electronic circuit protection
	Other faults	Electronic circuit protection
	Other function	Over-current, over-voltage, under-voltage, overload, instantaneous power-loss restart, ACC/DEC / RUN stall prevention, output terminal short circuit, grounding error, reverse block, direct start at power on and fault reset limit.

※1: The setting resolution above 100Hz is 1Hz when set by keypad, and 0.01Hz when set using serial communication from computer (PC) or programmable controller (PLC).

※2: Non-standard, un-filtered *iDrive* model numbers **EDX-020-21** to **EDX-075-21**, and **EDX-075-43** to **EDX-220-43** fitted with optional external filter are in accordance with EN61800-3 First Environment; Unrestricted Distribution when carrier frequency is set at 10KHz or less.

Non-standard, un-filtered *iDrive* model numbers **EDX-150-21** and **EDX-220-21**, fitted with optional external filter are in accordance with EN61800-3 First Environment; Unrestricted Distribution when carrier frequency is set at 10KHz or less.

Standard, filtered *iDrive* model numbers **EDX-020-21-E** to **EDX-075-21-E**, are in accordance with EN61800-3 First Environment; Restricted Distribution when carrier frequency is set at 10KHz or less.

Model numbers **EDX-150-21-E** and **EDX-220-21-E** are in accordance with EN61800-3 First Environment; Restricted Distribution when carrier frequency is set at 6KHz or less.

IP65 / NEMA4 *iDrive* models **EDX-020-21-E-N4(S)** to **EDX-220-21-E-N4(S)** and **EDX-075-43-E-N4(S)** to **EDX-220-43-E-N4(S)** are in accordance with EN61800-3 First Environment; Restricted Distribution when carrier frequency is set at 10KHz or less.

### 3.5 iDrive EDX connection diagram

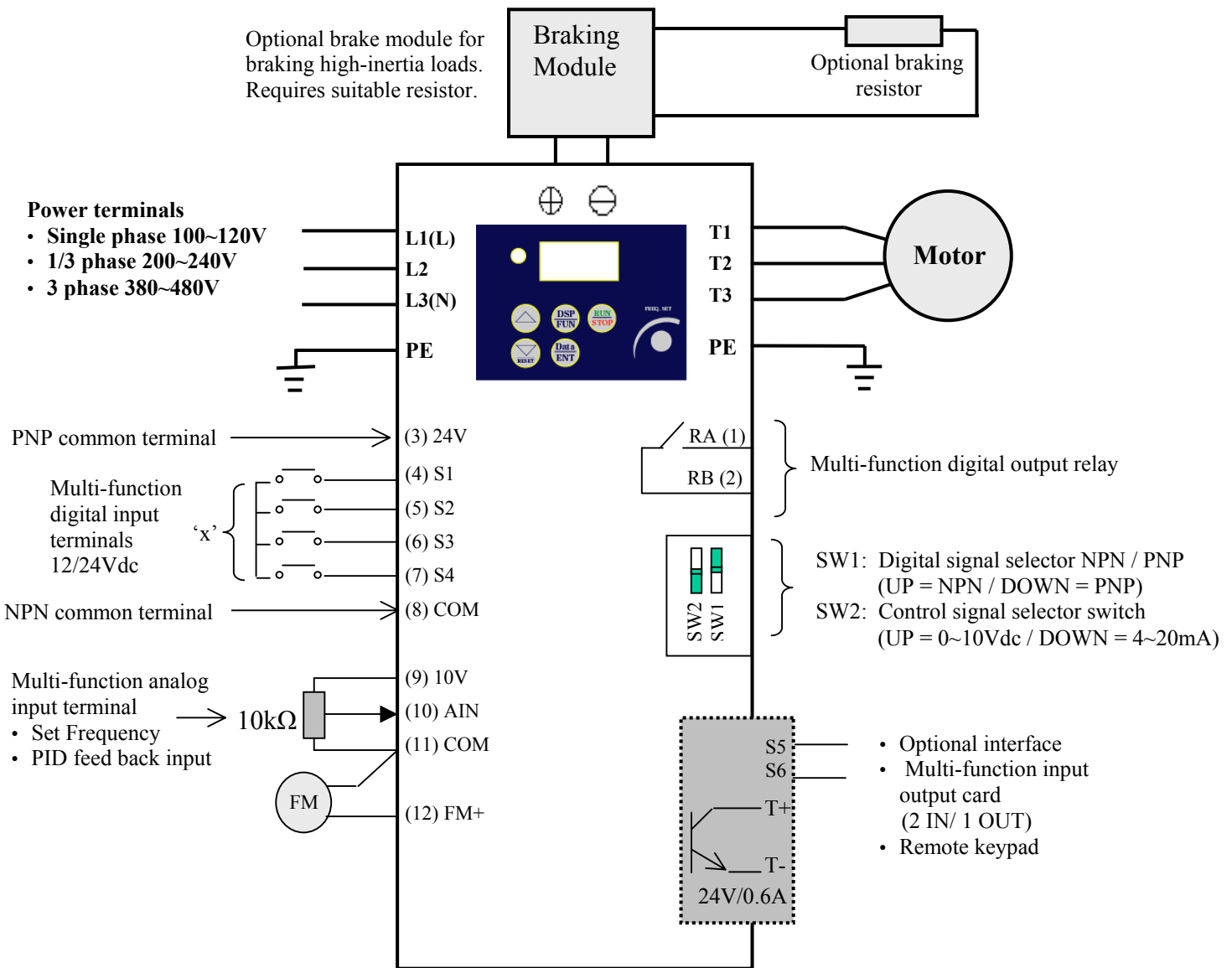

Note 1:- Connect point 'x' to either: -  
Terminal (3) (internal +24Vdc) for PNP mode (positive switching)

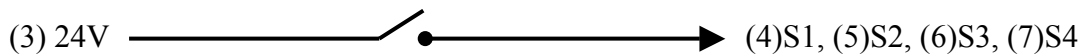

OR...

Terminal (8) (Common 0V) for NPN mode (negative switching).

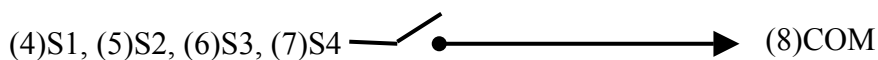

Note2:- External 24Vdc may be used to supply the external contacts at point 'x'.  
If so then connect the 0V of the external supply to Common (terminal 8).

### 3.6 Descriptions of *iDrive* Power and Control terminals

#### Power input, power output, and earth/ground terminal block descriptions

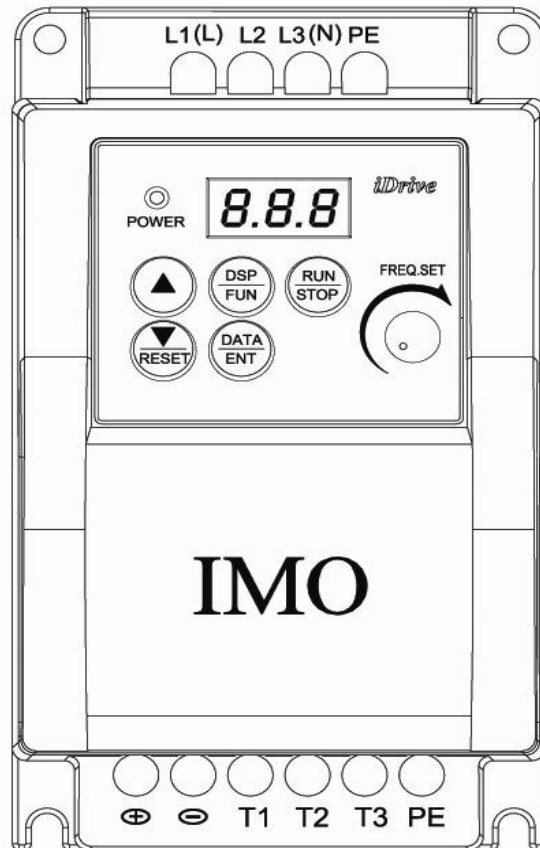

Terminal	Description
L1(L)	Main power input    Single-phase: L1/L3(N) Three-phase: L1/L2/L3
L2	
L3(N)	
⊕	DC link and braking module* connection terminals. Never connect resistors directly to these terminals or damage will occur!
⊖	
T1	Inverter output. Connect appropriate 3-phase AC induction motor to these terminals.
T2	
T3	
PE	Earth / Ground terminals (2 points)

\*A brake module is required for applications where a load with high inertia needs to be stopped rapidly.

Use a correctly rated braking module and resistor(s) to dissipate the energy generated by the load during stopping or rapid speed change for example otherwise *iDrive* may trip on over-voltage 'OV'.

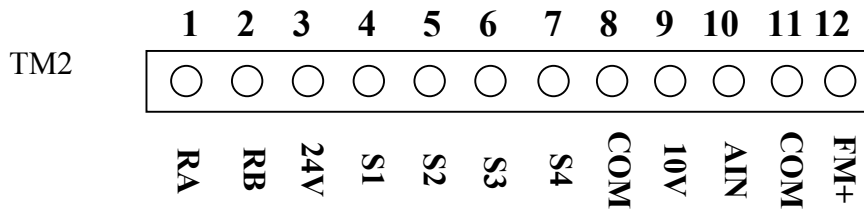
**Control signal terminal block description**

Terminal	Description	
RA	Multi-functional output terminals. Normally open relay contacts SPST	Rated contact capacity: (250VAC/10A resistive)
RB		(Refer to parameter b55 for functions)
10V	+10Vdc terminal. Supply for external potentiometer for speed reference.	
AIN	Analog frequency command input or PID feedback signal terminal. (Refer to parameter b41)	
24V	24Vdc common terminal; Frame size 1 maximum current = 100mA Frame size 2 maximum current = 150mA PNP (SOURCE) for inputs S1~S4 (and option card inputs S5 and S6). Set SW1 to 'PNP' position. Connect option card power supply if required.	
COM	0Vdc common terminal. NPN (SINK) for input, S1~S4 (and option card inputs S5 and S6). Set SW1 to 'NPN' position. Connect option card power if required. Also use this terminal for analogue input and analogue output signals - common.	
FM+	Multi-function analog output terminal, (refer to parameter b53 for functions) Output signal: 0-10Vdc proportional to b53 setting. Maximum output current = 25mA	

Terminal	Description
S1	Multi-function input terminals (refer to parameters b35~b38 descriptions) Maximum input current per terminal: Frame size 1 = 20mA. Frame size 2 = 25mA
S2	
S3	
S4	

## SW1 and SW2 function description

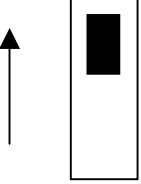
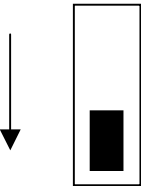
SW1	External signal logic	Remarks
	NPN input (SINK)	<b>Factory setting = PNP</b>
	PNP input (SOURCE)	

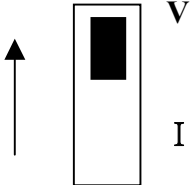
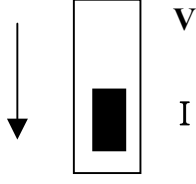
SW2	External input (for speed/frequency reference)	Remarks
	0~10Vdc analogue signal	Effective when Function A01= 002 (external analogue input to terminal AIN)  <b>Factory setting = V</b>
	4~20mA analogue signal	

### 3.7 iDrive Dimensions

**IP20 Frame 1:** 1-phase 100V: **EDX-020-11 ~ EDX-075-11**

1-phase 200V: **EDX-020-21 ~ EDX-075-21, EDX-020-21-E ~ EDX-075-21-E**

3-phase 200V: **EDX-020-23 ~ EDX-075-23**

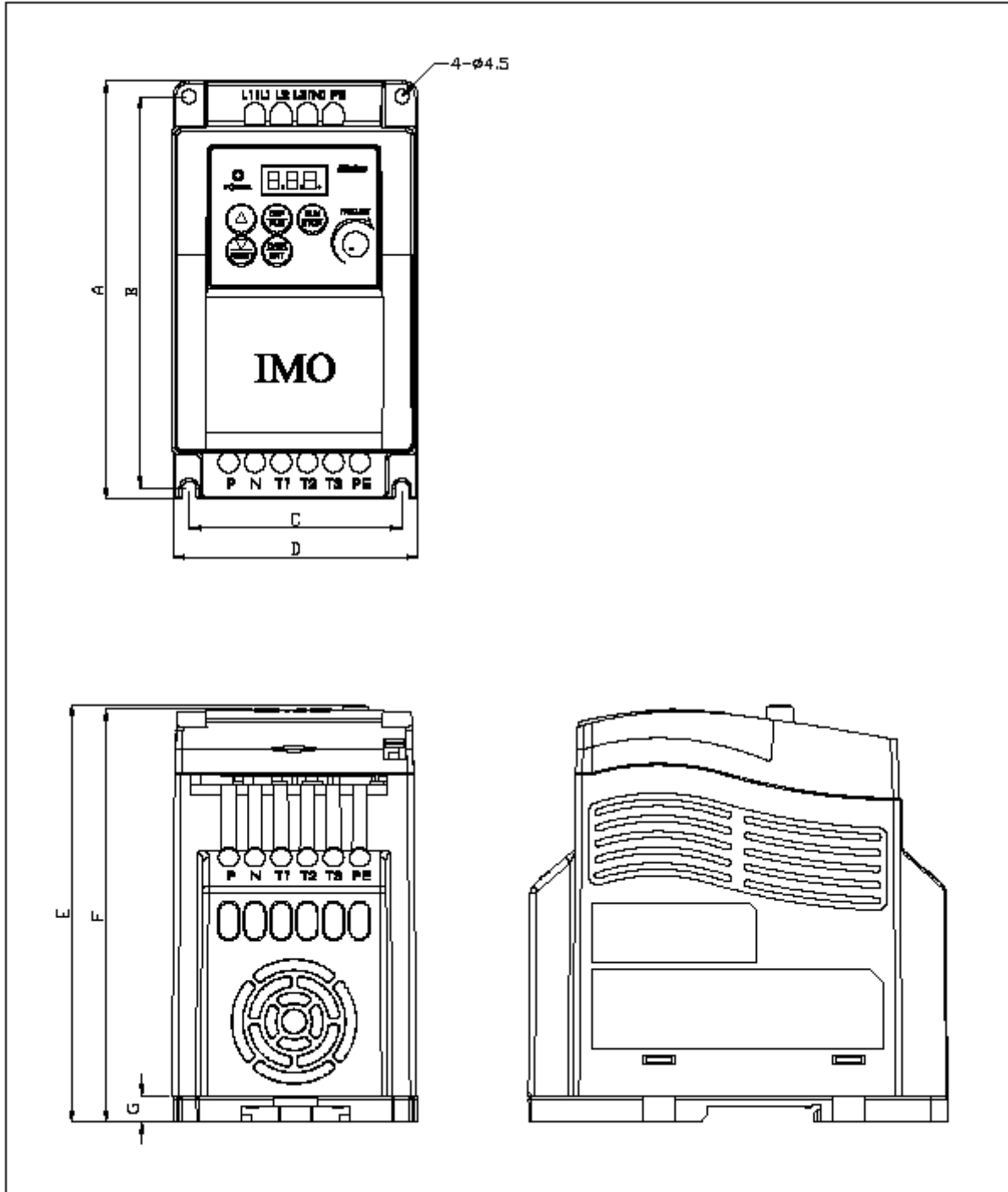

	A	B	C	D	E	F	G
Frame 1	132 / 5.2	123.5 / 4.86	67 / 2.64	77 / 3.03	130.5 / 5.13	128.45 / 5.06	8 / 0.315



**IP20 Frame 2:** 1-phase 200V: **EDX-150-21 ~ EDX-220-21; EDX-020-21-E ~ EDX-075-21-E**  
 3-phase 200V: **EDX-150-23 ~ EDX-220-23**  
 3-phase 400V: **EDX-075-43 ~ EDX-220-43; EDX-075-43-E ~ EDX-220-43-E**

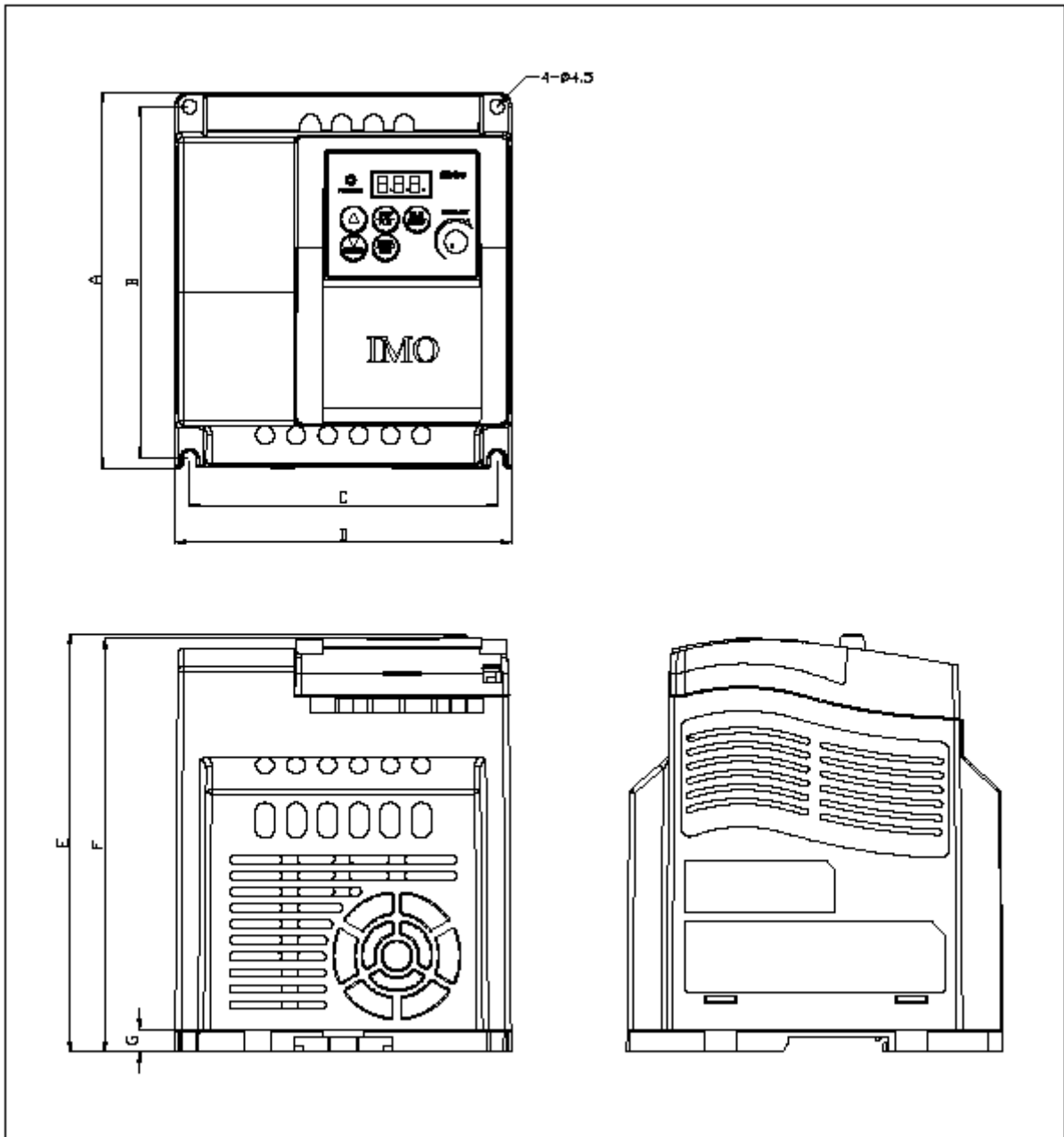

	A	B	C	D	E	F	G
Frame 2	132 / 5.2	123.5 / 4.86	108 / 4.25	118 / 4.65	148 / 5.83	144 / 5.67	8 / 0.315

**IP65 Frame 1:** 1-phase 100V models: **EDX-020-11-N4S ~ EDX-075-11-N4S**  
 1-phase 200V models: **EDX-020-21-E-N4S ~ EDX-075-21-E-N4S**

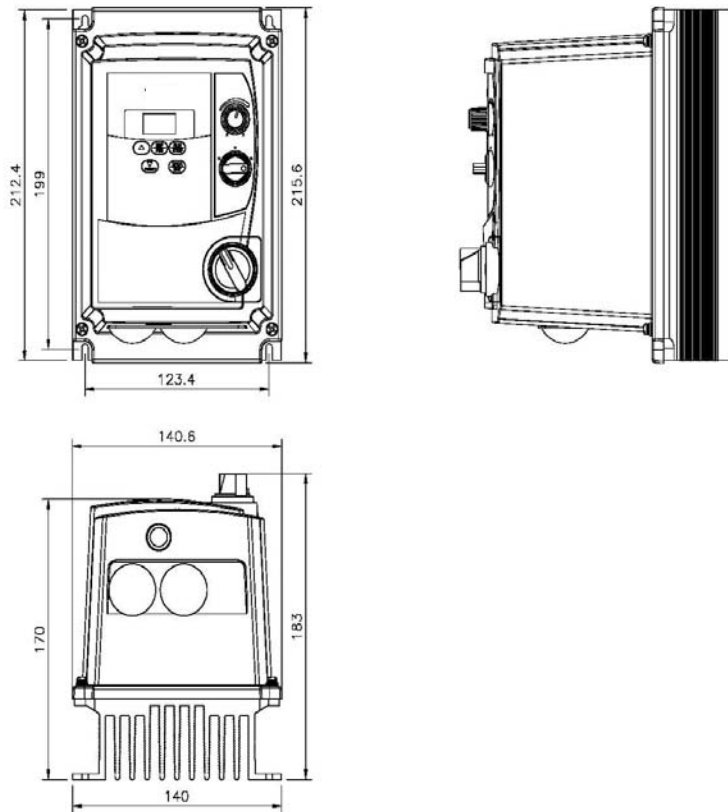

**IP65 Frame 2:** 1-phase 200V models: **EDX-150-21-E-N4S & EDX-220-21-N4S**  
 3-phase 400V models: **EDX-075-43-E-NS4 ~ EDX-220-43-E-N4S**

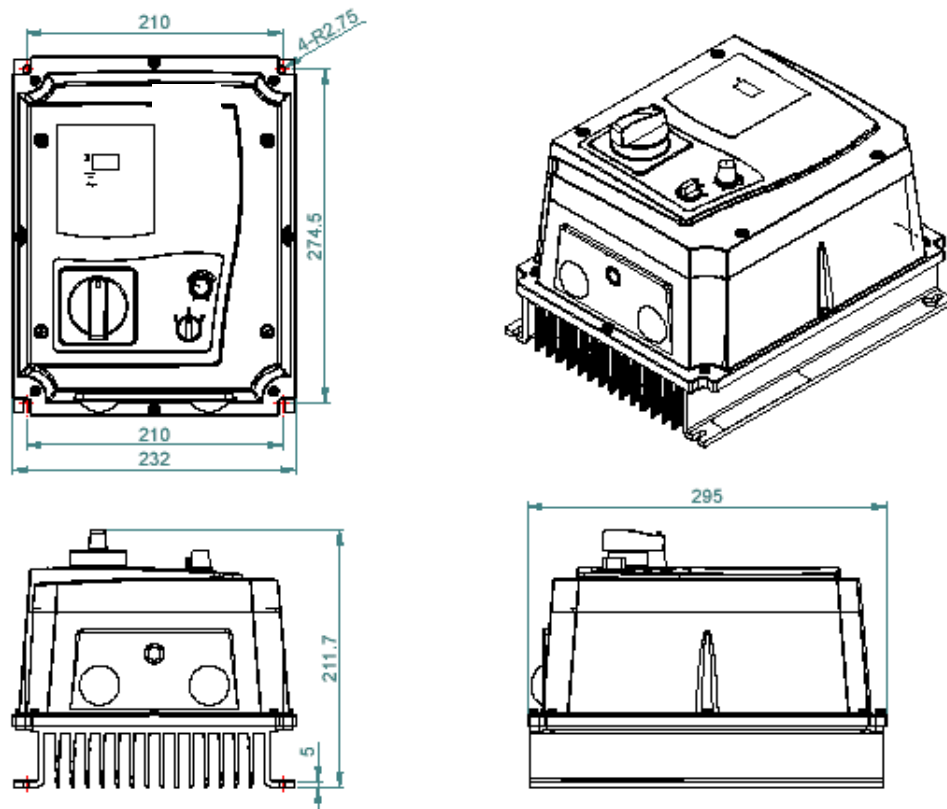

### 3.8 Multi-*iDrive* installation with regenerative loads

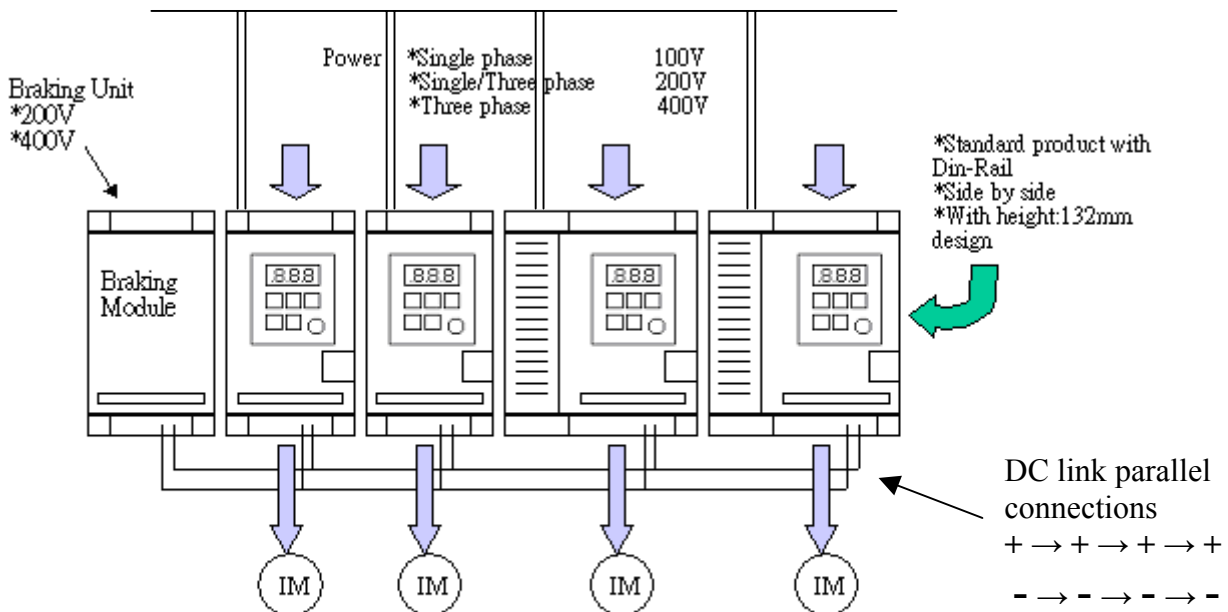

If all *iDrives* are of the same voltage rating, the DC bus connections of each can be connected together in parallel. Regenerated braking power from stopping of high inertia loads can then be dissipated or partly dissipated between all of the paralleled *iDrives*. If more energy requires dissipating, a braking module and resistors can be connected as shown above.

Note: All drives must power on at the same time\*.

Notes:

- \*If parallel connecting the DC busses of different capacity inverters; Must power up in sequence: Largest capacity first → smallest capacity last.
- DC fuses and/or other precautions may be necessary.
- Never connect ‘+’ terminals to ‘-’ terminals or damage will occur.

If in doubt consult your local *iDrive* distributor or dealer.

## Chapter 4 Programming instructions & Parameter list

### 4.1 Keypad

#### 4.1.1 Keypad layout



#### 4.1.2 Local and Remote operating modes

##### Local mode

Run Command

Set (**A00 = 000**): Run command only from **RUN / STOP** keys on the keypad.

Frequency command

Set (**A01 = 000**): UP/DOWN keys on keypad control the motor frequency (speed).

Set (**A01 = 001**): only the 'Freq.Set' potentiometer (VR) on the keypad can control the motor speed.

##### Remote mode

Run Command

Set (**A00 = 001**): Run command only by digital input to TM2 terminal S1 to S4.



Terminals S1 to S4 can be configured for 'RUN' input by setting functions (**b34 to b38 = 000 / 001**)

Frequency command

Set (**A01 = 002**): only external speed reference to TM2 terminal 10 (AIN) can control the motor speed.

Note: Switch SW2 and (**b61 = 000 / 001**) must be set for either 0-10V or 4-20mA input.

##### **Tip!**

Quick changeover between **LOCAL** and **REMOTE** control modes can be made by simultaneously pressing the  and the  keys on the keypad.

Modes can be 'toggled' by this method when commissioning for example. Note that the motor must be stopped before changeover is allowed.

### 4.1.3 Keypad navigation

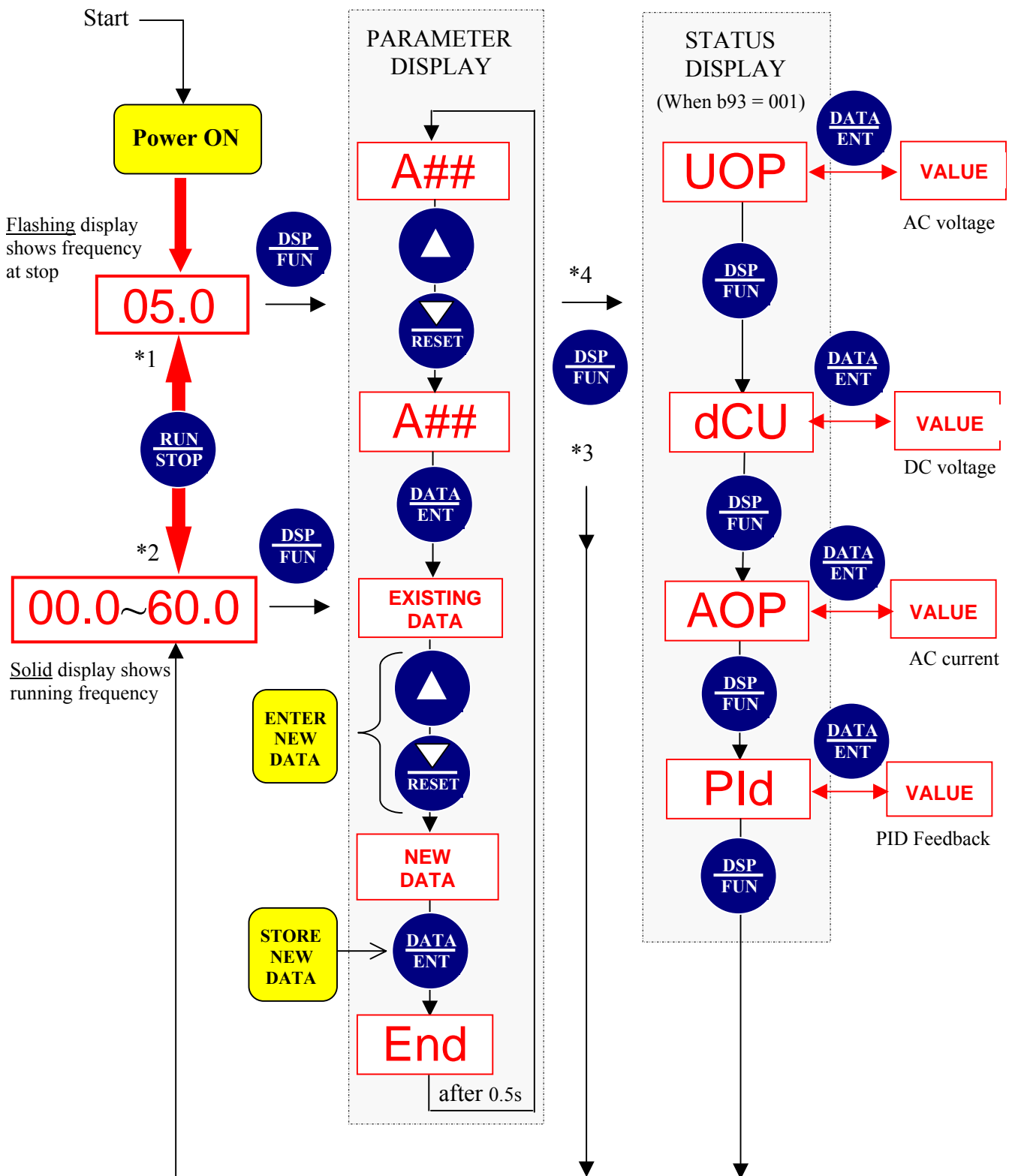

- \*1: Display flashes with set frequency in STOP mode.
- \*2: Display is steady (not flashing) with set frequency in RUN mode.  
(Required output frequency can be set during both STOP and RUN modes.)
- \*3: If parameter A12 = 000 (factory setting) then display returns to RUN/STOP frequency.  
If parameter A12 = 001, b parameters will now be visible.
- \*4: If parameter b93 = 001, STATUS DISPLAYS will now be opened.

## 4.2 Parameter functions

### Quick-Start 'A' parameter function list

Parameter Number	Function	Range / (Units)	Factory Setting	Notes
A00	Operation control	000: Keypad RUN/STOP keys 001: Terminals 002: RS232/485 Comms	000	
A01	Frequency control	000: Keypad UP/DOWN keys 001: Potentiometer on Keypad 002: AIN signal (TM2) 003: MFIT : Mot. Pot. function 004: RS232/485 Comms	000	
A02	Frequency high limit	01.0 ~ 200 (Hz)	50.0/60.0	*2
A03	Frequency low limit	00.0 ~ 200 (Hz)	00.0	*2
A04	Acceleration time 1	00.1 ~ 999 (s)	05.0	*1, *2
A05	Deceleration time 1	00.1 ~ 999 (s)	05.0	*1, *2
A06	Control mode select	000: Vector control 001: V/F control	001	*4
A07	V/F Pattern set	001 ~ 007	001	
A08	Output voltage at base frequency	198 ~ 264, 380 ~ 528 (V)	220 / 440	
A09	Base frequency	00.2 ~ 200 (Hz)	50.0/60.0	
A10	Torque Boost Gain [V/F]	00.0 ~ 30.0 (%)	00.0	*1
A11	Electronic thermal overload relay protection for motor (OL1)	000: Enable motor protection 001: Disable motor protection	000	
A12	Access to 'b##' parameters	000: b-parameters CLOSED 001: b-parameters OPEN	000	

### Advanced 'b' parameter function list (Access to these parameters by setting A12 = 001)

Parameter Number	Function	Range / (Units)	Factory Setting	Notes
b00	Acceleration time 2	00.1 ~ 999 (s)	05.0	*1, *2
b01	Deceleration time 2	00.1 ~ 999 (s)	05.0	*1, *2
b02	Slip Compensation Gain [V/F]	00.0 ~ 100 (%)	00.0	*1
b03	Motor No-Load Current [V/F]	--- (A)	---	*4
b04	Output Voltage at Max Frequency [V/F]	00.0 ~ 100 (%)	100	
b05	Mid Output Frequency [V/F]	00.1 ~ 200 (Hz)	25.0	
b06	Output Voltage at Mid Frequency [V/F]	00.0 ~ 100 (%)	50.0	
b07	Min Output Frequency [V/F]	00.1 ~ 200 (Hz)	00.5	
b08	Output Voltage at Min Frequency [V/F]	00.0 ~ 100 (%)	01.0	
b09	Motor Rated Current	--- (A)	---	*4
b10	Motor Rated Voltage	--- (V)	---	*4
b11	Motor Rated (Base) Frequency	--- (Hz)	---	*4
b12	Motor Rated Power	--- (KW)	---	*4
b13	Motor Rated Speed	--- (RPM/10)	---	*4

b14	Torque Boost Gain	001 ~ 450 (%)		
b15	Slip Compensation Gain	001 ~ 450 (%)		
b16	Low Frequency Dead-Band Voltage Compensation	000 ~ 040		
b17	DC Injection Braking Time	00.0 ~ 25.5 (s)	00.5	
b18	DC Injection Braking Start Frequency	01.0 ~ 10.0 (Hz)	01.5	
b19	DC Injection Braking Level	000 ~ 020 (%)	005	
b20	Skip Frequency 1	00.0 ~ 200 (Hz)	00.0	*1
b21	Skip Frequency 2	00.0 ~ 200 (Hz)	00.0	*1
b22	Skip Frequency Bandwidth	00.0 ~ 30.0 (+/-Hz)	00.0	*1
b23	Acceleration Stall Prevention Level	050 ~ 200 (%)	200	
b24	Deceleration Stall Prevention Level	050 ~ 200 (%)	200	
b25	Running Stall Prevention Level	050 ~ 200 (%)	200	
b26	Stall Prevention Deceleration Time	00.1 ~ 999 (s)	03.0	
b27	Acceleration Stall Prevention	000: Enabled 001: Disabled	000	
b28	Deceleration Stall Prevention	000: Enabled 001: Disabled	000	
b29	Running Stall Prevention	000: Enabled 001: Disabled	000	
b30	Stall Prevention Time During Running	000: According to (A05) 001: According to (b26)	000	
b31	Power Loss Auto Re-start	000: Enabled 001: Disabled	001	
b32	Auto Re-start Attempts	000 ~ 005	000	
b33	Auto-Start at Power ON	000: Auto-Start Enabled 001: Auto-Start Disabled	001	
b34	Reset Mode	000: Reset command available if RUN command is OFF 001: Reset command available if RUN is ON or OFF	000	
b35	Terminal S1 Function	000: RUN Forward 001: RUN Reverse	000	
b36	Terminal S2 Function	002: Preset Speed Command 1 003: Preset Speed Command 2 004: Preset Speed Command 3 005: JOG Frequency Command	001	
b37	Terminal S3 Function	006: Emergency STOP (E.S.) 007: Base Block (b.b.) 008: Select Accel 2 / Decel 2 009: Reset	005	
b38	Terminal S4 Function	010: UP Command 011: DOWN Command 012: Control Signal Switch	006	
b39	Terminal S5 Function	013: Communications Mode 014: Accel. / Decel. Prohibit 015: Master / Auxiliary Speed Signal	007	

b40	Terminal S6 Function	016: PID Disabled 017: Analog Frequency Signal Input Terminal AIN	009	
b41	Terminal AIN Function	018: PID feedback signal (AIN) 019: DC Brake (ON command)	017	
b42	Frequency UP/DOWN Control (MFIT)	000: UP/DOWN Control ON (Freq. Held at Power OFF) 001: UP/DOWN Control ON (Freq. Reset to 0Hz at OFF) 002: UP/DOWN Control ON (As 000 – UP/DOWN is Available when Output OFF)	000	
b43	S1 ~ S6 Digital Input Scan Time	001 ~ 100 (mS x 8)	010	
b44	Jog Frequency	00.0 ~ 200 (Hz)	05.0	*1
b45	Preset Frequency 1	00.0 ~ 200 (Hz)	05.0	*1
b46	Preset Frequency 2	00.0 ~ 200 (Hz)	05.0	*1
b47	Preset Frequency 3	00.0 ~ 200 (Hz)	10.0	*1
b48	Preset Frequency 4	00.0 ~ 200 (Hz)	20.0	*1
b49	Preset Frequency 5	00.0 ~ 200 (Hz)	30.0	*1
b50	Preset Frequency 6	00.0 ~ 200 (Hz)	40.0	*1
b51	Preset Frequency 7	00.0 ~ 200 (Hz)	50.0	*1
b52	Preset Frequency 8	00.0 ~ 200 (Hz)	60.0	*1
b53	0-10V Analogue Output Select	000: Output Frequency 001: Set Frequency 002: Output Voltage 003: DC Voltage 004: Output Current 005: PID feedback Signal	000	*1
b54	Analogue Output Gain	00.0 ~ 200 (%)	100	*1
b55	Multi-Function Output Relay RY1	000: RUN 001: Frequency Reached ( $\pm$ b57) 002: Frequency in Range ( $b56 \pm b57$ ) 003: Frequency Detected ( $>b56$ ) 004: Frequency Detected ( $<b56$ ) 005: Fault 006: Auto Reset / Restart 007: Momentary Power Loss 008: Emergency Stop (E.S.) 009: Base Block (b.b.) 010: Motor Overload 011: Inverter Overload 012: xxx Not Used xxx 013: Power ON 014: Communication Error 015: Output Current ( $>b58$ )	000	
b56	Output Frequency Reached Set Value	00.0 ~ 200 (Hz)	00.0	*1
b57	Frequency Detection Range	00.0 ~ 30.0 ( $\pm$ Hz)	00.0	*1



b58	Output Current Reached Set Value	000 ~ 100 (%)	000	
b59	Output Current Detection Time	00.0 ~ 25.5 (S)	00.0	
b60	Multi-Function Output Transistor (T+ / T- Option Card)	000: RUN 001: Frequency Reached ( $\pm$ b57) 002: Frequency in Range (b56 $\pm$ b57) 003: Frequency Detected (>b56) 004: Frequency Detected (<b56) 005: Fault 006: Auto Reset / Restart 007: Momentary Power Loss 008: Emergency Stop (E.S.) 009: Base Block (b.b.) 010: Motor Overload 011: Inverter Overload 012: xxx Not Used xxx 013: Power ON 014: Communication Error 015: Output Current (>b58)	005	
b61	AIN Signal Select	000: 0-10V 001: 4-20mA	000	
b62	AIN Gain	000 ~ 200 (%)	100	*1
b63	AIN Bias	000 ~ 100 (%)	000	*1
b64	AIN Bias	000: Positive 001: Negative	000	*1
b65	AIN Slope Direction	000: Positive 001: Negative	000	*1
b66	AIN Analogue Input Scan Time	000 ~ 100 (mS x 4)	050	
b67	PID Operation Mode	000: PID Control Disabled 001: PID Bias D Control 002: PID Feedback D Control 003: PID Bias D Reverse Control 004: PID Feedback D Reverse Control	000	
b68	Feedback Gain	0.00 ~ 10 (%)	1.00	*1
b69	P: Proportional Gain	0.00 ~ 10 (%)	01.0	*1
b70	I: Integral Time	00.0 ~ 10 (s)	10.0	*1
b71	D: Differential Time	0.00 ~ 10 (s)	0.00	*1
b72	PID Bias/Offset	000: Positive Direction 001: Negative Direction	000	*1
b73	PID Bias Adjust	000 ~ 109 (%)	000	*1
b74	PID Filter Time	00.0 ~ 02.5 (s)	00.0	*1
b75	PID Sleep Level	00.0 ~ 200 (Hz)	00.0	
b76	PID Sleep On-Delay Time	00.0 ~ 25.5 (s)	00.0	
b77	Serial Communications Address	001 ~ 254	001	*3 *4

b78	Serial Communications Baud Rate	000: 4800 (bps) 001: 9600 002: 19200 003: 38400	003	*3 *4
b79	Stop Bits	000: 1 Bit 001: 2 Bits	000	*3 *4
b80	Parity Bit	000: No Parity 001: Even Parity 002: Odd Parity	000	*3 *4
b81	Data Bits	000: 8 Bits 001: 7 Bits	000	*3 *4
b82	Communication Error Detection Time	00.0 ~ 25.5 (s)	00.0	*3
b83	Communication Error Response	000: Decelerate to Stop (A05) 001: Coast to Stop 002: Decelerate to Stop (b01) 003: Continue to Run	000	*3
b84	Remote Keypad Frequency Control (by)	000: UP/DOWN Keys 001: Potentiometer (VR)	000	
b85	Remote Keypad – Enable / Disable (and action if keypad cable fault)	000: Remote keypad disabled 001: Remote keypad enabled (Motor stopped as set by b92) 002: Remote keypad enabled (No stop, runs at Set Freq)	000	
b86	Carrier Frequency	004 ~ 016 (kHz)	010	
b87	Inverter Cooling Fan	000: Auto Run by Inverter °C 001: Run When Output On 002: Always Run 003: Always Stop	001	IP20 Only.
b88	Motor Rotation Direction	000: Forward 001: Reverse	000	*1
b89	Inverter Power Code (Read Only)	See following description		
b90	RUN / STOP / Direction Switching	000: FWD/STOP-REV/STOP 001: RUN/STOP-FWD/REV 002: 3-Wire – RUN/STOP	000	
b91	Reverse RUN Instruction	000: Reverse Enabled 001: Reverse Disabled	000	
b92	STOP Method	000: Decelerate to STOP 001: Coast to STOP	000	
b93	Operation Monitor	000: Display Hz Only 001: Display Hz, A, V, PID, etc	000	
b94	Copy Module	000: Module Disabled 001: Copy <i>iDrive</i> to Module 002: Copy Module to <i>iDrive</i> 003: Read / Write Check	000	*3
b95	All Data Reset to Factory Settings	010: Reset to Default (50Hz) 020: Reset to Default (60Hz)	000	
b96	Software Version (Read Only)	CPU Version		*3 *4
b97	Alarm Log	Last 3 fault records		*3 *4

**Note: \*1: Parameter value can be modified when *iDrive* output is on (motor running).**

**\*2: Frequency resolution is 1Hz for settings above 100 Hz.**

**\*3: Cannot be modified during communication.**

**\*4: Do not change while making factory setting.**

**b95 factory setting is 010 (50Hz) and motor parameter value is 140.**

**b95 factory setting is 020 (60Hz) and motor parameter value is 170.**

## 4.3 Parameter Function Description

### Basic 'A' parameter functions

<b>A00 Operation Control (Run / Stop Command)</b>	<b>000: Keypad</b>
	<b>001: External Terminal</b>
	<b>002: Communication Control</b>

- 1.) A00 = 000, *iDrive* RUN/STOP command is from keypad.
- 2.) A00 = 001, *iDrive* RUN/STOP command is from external terminals.
- 3.) A00 = 002, *iDrive* RUN/STOP command by serial communication.

<b>A01 Frequency Control (Speed Reference Source)</b>	<b>000: UP/Down keys on keypad</b>
	<b>001: VR on keypad (Potentiometer)</b>
	<b>002: Control terminal 10 input signal (TM2)</b>
	<b>003: Multi-function input terminal UP/DOWN function</b>
	<b>004: Frequency set by serial communication (When b85 = 1: Remote keypad has priority)</b>

- 1.) A01 = 001, when one of parameter group b35 ~ b38, or b41 is set to 015 and multi-function input terminal is OFF, the frequency is set by VR on keypad. If the multi-function input terminal is ON, the frequency is set by analog signal (auxiliary speed) from TM2.
- 2.) A01 = 002, when one of parameter group b35 ~ b38, or b41 is set to 015 and multi-function input terminal is OFF, the frequency is set by analog signal (auxiliary speed) from TM2. If the multi-function input terminal ON, the frequency is set by VR on keypad.
- 3.) Up/Down terminal: Refer to description of parameter group b35~ b38 (multi-function input Terminal)
- 4.) Priority of reading frequency command: Jog > preset frequency > (Keypad▲▼ or TM2 UP/Down or communication)

**A02 Frequency upper limit (Hz) : 01.0 - 200**

**A03 Frequency lower limit (Hz): 00.0 - 200**

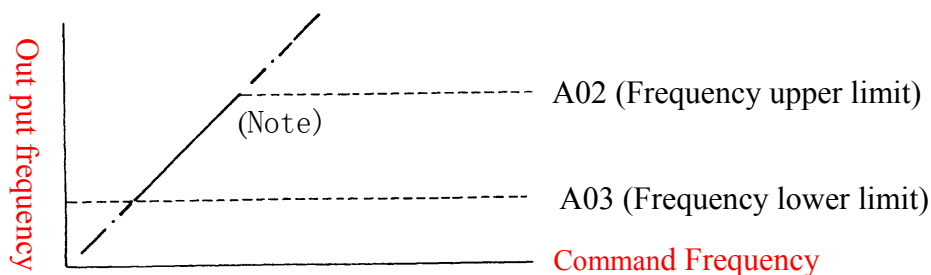

**Note: If A02 = 0 Hz and frequency command = 0Hz, the *iDrive* will zero-speed stop.**

**If A03 > 0 Hz and frequency command = 0 Hz *iDrive* output will be at A03 set value.**

**A04 Acceleration time 1 (s): 00.1 – 999**  
**A05 Deceleration time 1 (s): 00.1 – 999**

Formula for acceleration/deceleration time:  
 Denominator is based on factory setting in Sensorless Vector control

- a) Motor rated frequency (Sensorless Vector control).
- b) Max output frequency (V/F control).

a)

$$\text{Acceleration time} = A04 \times \frac{\text{Set frequency}}{b11 \text{ (rated frequency)}} \qquad \text{Deceleration time} = A05 \times \frac{\text{Set frequency}}{b11 \text{ (rated frequency)}} \rightarrow \text{vector}$$

b)

$$\text{Acceleration time} = A04 \times \frac{\text{Set frequency}}{A09 \text{ (Max output frequency)}} \qquad \text{Deceleration time} = A05 \times \frac{\text{Set frequency}}{A09 \text{ (Max output frequency)}} \rightarrow \text{V/F}$$

**A06: Control mode** **Vector control or V/F control**

A06 = 000: *iDrive* operates in Sensorless Vector mode. Dynamic response to changing load is improved, motor starting torque increased and low-speed operation is more stable. For better S/V control it is also necessary to input correct values into parameters A08, A09, b09 – b16.

A06 = 001: *iDrive* operates in V/F mode. Standard performance for fans, pumps, and other non-demanding (non-dynamic) loads.

**A07: V/F Preset patterns 1 – 7**

A07 = 007.  
 Selects user configurable V/F pattern by setting parameters A09, b04 – b08.  
 Care should be taken when using this feature as incorrect setting of these parameters may cause motor over-heating or incorrect operation.

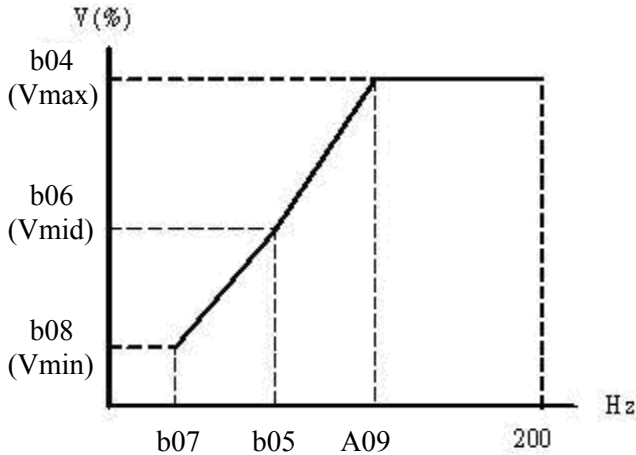

A07 = 001 ~ 006 User selectable fixed V/F patterns (refer to following table).

E.U.	Spec.	A07	V/F Pattern	U.S. CAN	Spec.	A07	V/F Pattern
50 Hz Motors	General	001		60 Hz Motors	General	004	
	High start torque	002			High start torque	005	
	Variable torque	003			Variable torque	006	

<b>A08 V/F Base Voltage</b>
<b>A09 V/F Base Frequency</b>

In example below: A09 = 50Hz, b04 =100%  
 If A08 setting is 200~240V, then output voltage for the pattern:

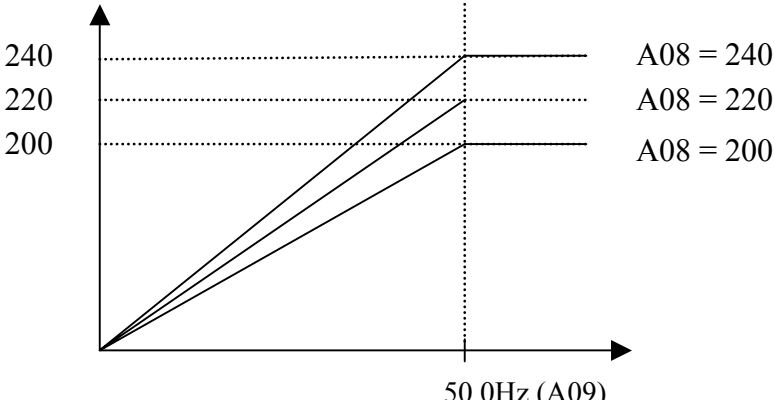

The *iDrive* output voltage cannot exceed its input voltage.

<b>A10 V/F Torque Boost Gain 00.0 – 30.0%</b>
---

<b>A11 Electronic thermal overload protection for motor (OL1) :</b>	<b>000: Protection Enabled 001: Protection Disabled</b>
---	---

Set A11 = 000 and **b09** to rated motor current (Amps) to give correct thermal overload protection.

<b>A12 Advanced parameter functions display</b>	<b>000: Disable access to advanced parameters (b parameters) 001: Enable access to advanced parameters (b parameters)</b>
---	---

A12 = 000. Parameter group ‘b’ cannot be displayed or accessed.

A12 = 001. Enable display and access parameter group ‘b’.

**Advanced 'b' parameters functions****b00 Acceleration time 2 (s): 00.1 – 999****b01 Deceleration time 2 (s): 00.1 – 999****b02 V/F Slip Compensation Gain 00.0 – 100%****b03 Motor no-load current (A)**

Motor no-load current differs with *iDrive* capacity b89. Adjust according to motor information.

<b>b04: Output voltage ratio at max. frequency (%)</b>	<b>00.0 – 100%</b>
<b>b05: Mid frequency (Hz)</b>	<b>00.1 – 200Hz</b>
<b>b06: Output voltage ratio at mid. frequency (%)</b>	<b>00.0 – 100%</b>
<b>b07: Min. output frequency (Hz)</b>	<b>00.1 – 200Hz</b>
<b>b08: Output voltage ratio at min. frequency (%)</b>	<b>00.0 – 100%</b>

b04~b08 please refer to A07 description

**b09 Motor rated current (A)****b10 Motor rated voltage (V)****b11 Motor rated base frequency (Hz)****b12 Motor rated power (kW)****b13 Motor rated speed (RPM)****b14 Torque Boost Gain (Only for vector control, A06 = 001)**

If motor load torque increases, this function increases the available output torque to match the load.

$$\Delta Te = \underset{\text{(load current)}}{I} \times \underset{\text{(torque boost)}}{\text{Gain}}$$

- Torque/Speed curve pattern:

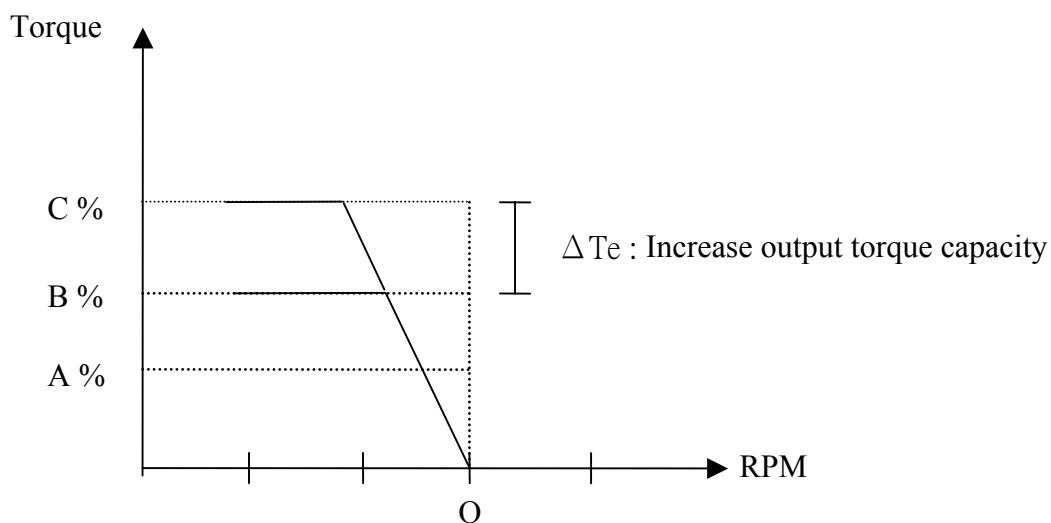

- Operating frequency range: 0 ~ Motor rated frequency



- When the motor output torque is not enough, increase b14 set value.
- If the motor vibrates or becomes very hot decrease b14 set value.
- If running at low speeds for long periods, high b14 set value can cause the motor to overheat
- The maximum output torque limit is proportional to the *iDrive* rated current.
- If increasing b14 set value causes the output current to be too large, increase b03 set value.

**b15 Slip Compensation Gain (Only for vector control, A06 = 001)**

If the detected motor load is too large, speed will drop. Increase gain b15 to compensate.

$$\Delta F_{\text{slip}} = \underset{\text{(load current)}}{I} \times \underset{\text{(slip compensation)}}{\text{Gain}}$$

- Torque/Speed curve pattern:

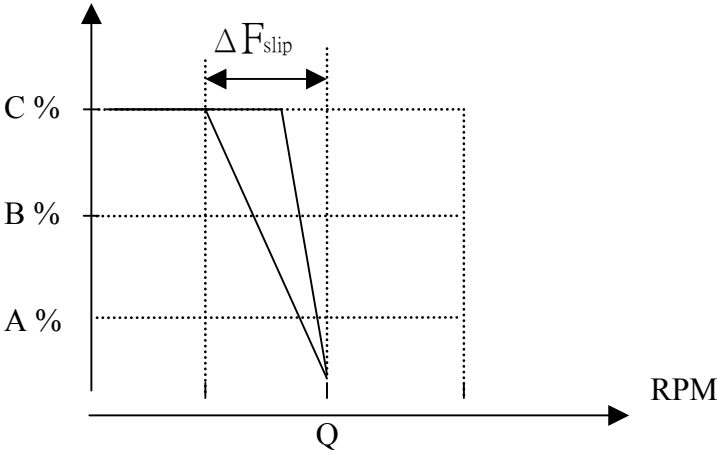

- Operating frequency range: 0 ~motor rated frequency.
- When the motor load is high, speed will decrease (slip). Increase b15 set value to compensate.
- If the motor vibrates or becomes very hot decrease b14 set value.
- The maximum rotational output speed limit is fixed by the motor maximum set frequency.

**b16 Low Frequency DB Voltage Compensation (Only for Vector control, A06 = 001)**

Increasing b16 set value will increase output voltage and low frequency torque.

- Output voltage/frequency pattern:

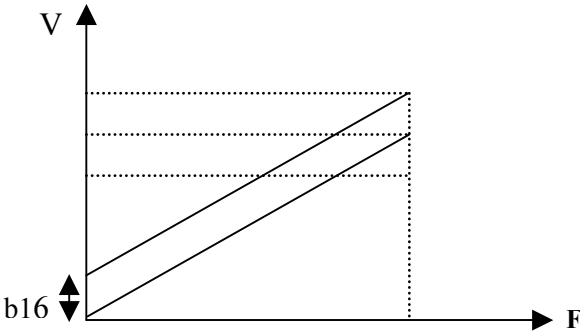

- Operating frequency range: 0~10HZ / 50HZ  
0~12HZ / 60HZ
- At low operating frequency: -  
When the motor output torque is not enough increase b16 set value.

**b17 DC braking time (s) 00.0~25.5**  
**b18 DC braking start frequency (Hz) 01.0~10.0**  
**b19 DC braking level 00.0~20.0%**

b17 / b18: DC braking time and start frequency, as following figure:

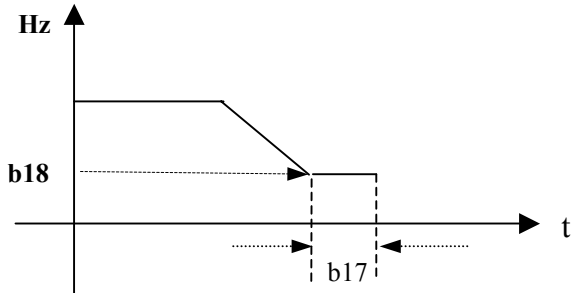

**b20 Skip Frequency 1 (Hz) : 00.0 – 200**  
**b21 Skip Frequency 2 (Hz) : 00.0 – 200**  
**b22 Skip Frequency Hysterisis (± Hz) : 00.0 – 30.0**

Example: When b20 = 10.0Hz  
 b21 = 20.0Hz  
 b22 = 02.0Hz

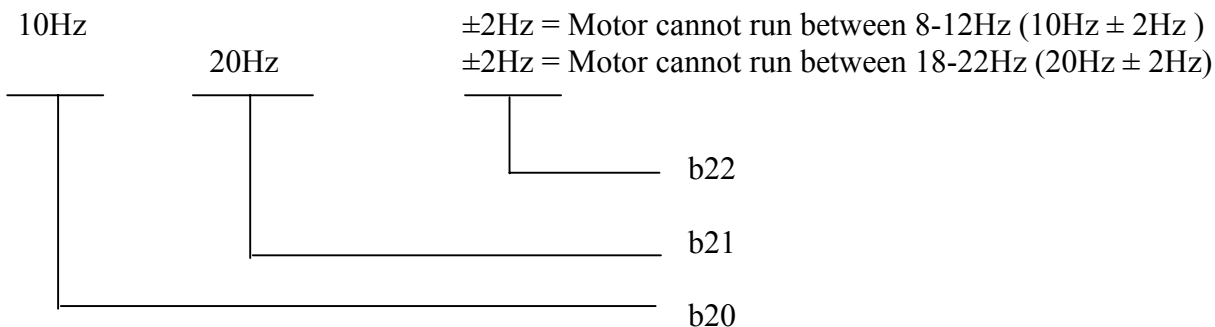

**b23 Acceleration stall-prevention level: 050% ~ 200%**  
**b24 Deceleration stall-prevention level: 050% ~ 200%**  
**b25 Run stall-prevention level: 050% ~ 200%**  
**b26 Stall prevention deceleration time: 00.1 ~ 999s**  
**b27 Acceleration stall-prevention:**  
 = 000: Enable Stall prevention during acceleration.  
 = 001: Disable Stall prevention during acceleration.  
**b28 Deceleration stall-prevention:**  
 = 000: Enable Stall prevention during deceleration.  
 = 001: Disable Stall prevention during deceleration.  
**b29 Run stall-prevention:**  
 = 000: Enable Stall prevention in Run mode.  
 = 001: Disable Stall prevention in Run mode.  
**b30 Stall prevention time during run mode.**  
 = 000: according to A05 (Deceleration Time 1).  
 = 001: according to b26.

- 1.) When the acceleration time is set too short the *iDrive* may trip on Over-Current (OC).  
If the time accelerating time cannot be increased use stall-prevention. A stall-prevention level needs to be programmed and when the inverter detects this level it freezes the acceleration ramp until the current falls below the set level, then continues accelerating.
- 2.) When the Deceleration time is set too short the *iDrive* may trip on Over-Voltage (OU).  
If the time deceleration time cannot be increased then stall-prevention can be used. A stall-prevention level has to be programmed and when the inverter detects this level it holds the deceleration ramp until the DC link voltage falls below the factory set level, then continues decelerating.
- 3.) The *iDrive* could stall during run mode due to an impact load or sudden changes of the load. Stall prevention in run mode will detect a programmed stall level (b25) for a period of time (b30) , if the level exceeds b25 , then the *iDrive* reduces its output frequency (speed) to provide the required additional torque to overcome the stall condition. Once this level is below the programmed stall level then it ramps up to its normal running speed.

<b>b31 Auto restart on momentary power loss. 000: Enabled</b> <b>001: Disabled</b>
---

b31 = 000: Auto restart after a momentary power loss is enabled on resumption of power and application of run signal, according to setting of parameter A00.

The *iDrive* will carry out an auto speed search, once the motor speed and direction are found then it will accelerate to the running speed prior to the power loss.

b31 = 001: Auto restart disabled.

<b>b32 Auto restart times: 000 ~ 005</b>
--

1.) b32 = 000: The *iDrive* will not auto-restart on fault trip.

2.) b32 > 000

The *iDrive* will carry out an auto-speed search 0.5 sec after the fault trip, while the output is switched off and the motor is coasting to stop.

Once the rotating speed is determined the *iDrive* will accelerate or decelerate from this speed to the running speed before the fault.

3.) Auto restart will not occur following OL1, OL2, OH, or BB alarms.

Note:- Auto restart will not function while DC injection braking or decelerating to stop.

<b>b33 Auto-start on power up</b>	<b>000: Enable direct start on power up.</b> <b>001: Disable direct start on power up.</b>
-----------------------------------	---

**⚠ Danger:**

1.) When b33 = 000 and external run mode (A00 = 001) are selected and a RUN command is present, the *iDrive* will auto-start the motor when power is applied.

*This feature should only be considered when all safety implications of its use have been investigate, risk assessment for maintenance, use of warning labels etc.*

2.) When b33 = 001 and external run mode (A00 = 001) are selected, and a RUN command is present, the motor will not auto-start when power is applied to the *iDrive*.  
The *iDrive* display will flash and SP1' error message. It can only restart after the RUN command has been removed then reapplied.

<b>b34 Reset mode</b>	<b>000: Reset is enabled only when a RUN command is OFF.</b>
	<b>001: Reset is enabled when a RUN command is OFF or ON.</b>

b34 = 000. Fault cannot be reset therefore *iDrive* cannot start if a RUN command is ON (A00=001)

<b>b35 ~ b38, b41</b>	<b>Selectable Functions for input terminals (S1 - S4 &amp; AIN )</b>
	<b>000: Run Forward</b>
	<b>001: Run Reverse</b>
	<b>002: Preset Speed Command 1</b>
	<b>003: Preset Speed Command 2</b>
	<b>004: Preset Speed Command 3</b>
	<b>005: Jog frequency Command</b>
	<b>006: Emergency stop (E.S.)</b>
	<b>007: Base Block (b.b.)</b>
	<b>008: Switching to 2nd acceleration / deceleration time</b>
	<b>009: Reset</b>
	<b>010: Up command</b>
	<b>011: Down command</b>
	<b>012: Control signal switch</b>
	<b>013: Communication mode. Disable – Enable.</b>
	<b>014: Acceleration / deceleration prohibit</b>
	<b>015: Master / Auxiliary speed switch</b>
	<b>016: PID function prohibit</b>
	<b>017: Analog frequency signal input (terminal AIN)</b>
	<b>018: PID feedback signal (terminal AIN)</b>
<b>019: DC Brake (ON command)</b>	

- 1.) S1~S4 & AIN on TM2 are multi-function input terminals (MFIT); configure as shown above.
- 2.) Parameters b35~b38, and b41 control the function of each terminal as shown below:  
b35 controls terminal S1, b36 controls terminal S2, b37 controls terminal S3, etc

**b35 ~ b38 (or b41) = 000/001 (Forward/ Reverse)**

Forward command ON means motor will run forward, when OFF, the motor stops. b35 factory default is forward command.

Reverse command ON means motor will run in reverse, when OFF, the motor stops. b36 factory default is reverse command.

If forward and reverse commands are ON simultaneously the motor will stop.

**b35 ~ b38 (or b41) = 002~004 (Preset Speed Command 1~3)**

When a run signal is applied and the selected external multi-function input terminal is on, the *iDrive* will run at one of 8 preset speeds, which are controlled by the status of the terminals. The corresponding speeds are as that programmed in parameters b44 to b52 as shown in the table below.

**b35 ~ b38 (or b41) = 005 (Jog Frequency Command)**

When run signal is applied and the selected external multi-function input terminal is on and set to Jog speed, the *iDrive* will run according to b44.

**Priority: Jog > Preset Speed**

Preset Speed Command 3 Set value = 004	Preset Speed Command 2 Set value = 003	Preset Speed Command 1 Set value = 002	Jog Frequency Command Set value = 005	Output frequency set value
X	X	X	1	b44
0	0	0	0	b45
0	0	1	0	b46
0	1	0	0	b47
0	1	1	0	b48
1	0	0	0	b49
1	0	1	0	b50
1	1	0	0	b51
1	1	1	0	b52

**b35 ~ b38 (or b41) = 006: Emergency Stop (E.S)**

The *iDrive* will decelerate the motor to stop on receiving the external emergency stop signal.

The display will be flashing 'E.S.'

The *iDrive* will only start the motor again when the Emergency Stop signal is removed and the start signal is turned off and then on again (remote start mode) or the Run key is pressed in (keypad mode).

Removing the Emergency Stop signal before the *iDrive* has fully stopped the motor will not inhibit the Emergency Stop operation.

Output relay can be set to Emergency Stop fault by setting b55 = 008

**b35 ~ b38 (or b41) = 007: Base Block (b.b.)**

The *iDrive* will stop the motor immediately on receiving a Base Block signal regardless of setting of b92 and display flashes '**b.b.**' The *iDrive* auto restarts in speed search when b.b. is signal removed.

**b35 ~ b38 (or b41) = 008: Switching to Acceleration time 2 / Deceleration time 2**

When terminal is ON the 2nd acceleration / deceleration ramps are selected.

**b35 ~ b38 (or b41) = 009: Reset command**

Reset command ON. The *iDrive* output will be disabled. Resettable faults will be cleared.

**b35 ~ b38 (or b41) = 010 / 011: UP / DOWN function: (According to acceleration/deceleration time)**

**Set A01 = 003**, to enable UP/DOWN function. The UP/DOWN key on Keypad is unavailable for changing frequency directly in this mode.

**Set b42 = 000**, When an UP/DOWN signal is ON, the *iDrive* accelerates / decelerates the motor to a frequency and stops accelerating / decelerating when the UP/ DOWN signal is removed. The motor will continue at this speed until another command is given.

The *iDrive* will decelerate the motor to stop or free run to stop when the run command is OFF according to b92. The frequency at which the *iDrive* stops the motor will be stored in b45.

In this mode the UP/DOWN key is unavailable for modifying frequency. Use b45 to modify.

**Set b42 = 001**, The *iDrive* will run from 0Hz on receiving a run command.

UP/DOWN action is similar to above description. When the run command is removed, the motor will decelerate to stop or free run to stop (0 Hz) according to setting of b92.

The *iDrive* will output from 0Hz in next operation.

**Note: UP/ DOWN commands are disabled if both terminals are ON at the same time.**

**b35 ~ b38 (or b41) = 012: Control Signal Switch**

Terminal OFF: Operation signal / frequency reference signal is controlled by A00/A01.

Terminal ON: Operation signal / frequency signal is controlled by keypad (not controlled by A00/A01).

**b35 ~ b38 (or b41) = 013: Communication Mode Select.**

**Terminal OFF:** In communication mode, the *iDrive* is controlled by master (PC or PLC) run and frequency signals and also allowed to modify parameters. The Keypad and TM2 run/frequency signal is not available at this time. The Keypad is only available for displaying voltage / current / frequency and parameters can be read but not modified. **Emergency stop is operational.**

**Terminal ON:** PC/PLC can read and modify parameters. Note that ALL operating controls are from keypad. (Not effected by setting of A00 & A01).

**b35 ~ b38 (or b41) = 014: Acceleration/deceleration disable.**

When external control terminal ON, the *iDrive* will stop accelerating/ decelerating until the signal is released. The motion is as follows:

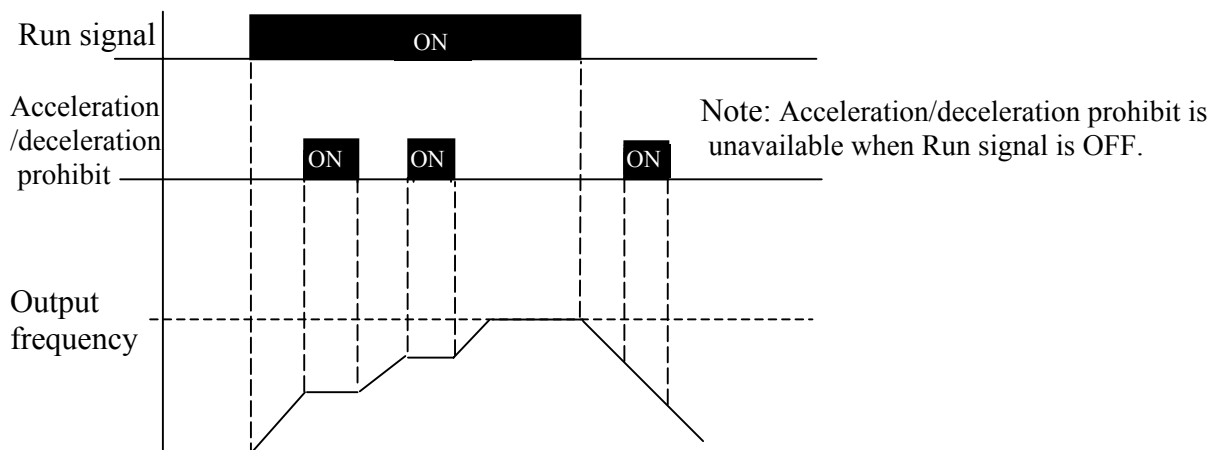
**b35 ~ b38 (or b41) = 015 Master/Auxiliary speed switch**

1) A01 = 001: When one of the parameters b35 ~ b38 (or b41) is set to 015, and terminal is OFF, the frequency is set by the VR on the Keypad (Master speed).

When multi-function input terminal is ON, the frequency is set by the analog signal on TM2 (Auxiliary speed AIN).

2.) A01 = 002: When one of the parameters b35 ~ b38 (or b41) is set to 015, and terminal is OFF, the frequency is set by the analog signal on TM2, (Master Auxiliary speed AIN).

When terminal is ON, the frequency is set by the VR on the Keypad (Auxiliary speed).

**b35 ~ b38 (or b41) = 016 (PID function disable)**

When input terminal is ON, PID functions set by b67 are disabled.

When input terminal is OFF, PID functions are enabled.

**b41 = 017 Analog frequency signal input (Terminal AIN)**

Frequency reference is set by 0-10Vdc or 4-20mA on terminal AIN, set by b61 and SW2.

**b41 = 018 PID Feedback signal input (Terminal AIN)**

PID feedback can be connected to AIN terminal 0-10Vdc/0~20mA or 2~10V/4-20mA as set by b61 and SW2.

**b35 ~ b38 = 019 DC Brake signal**

When DC injection is selected (b17~b19) and TM2 DC Brake signal is OFF brake time is set by value of b17; When TM2 DC Brake signal is ON, DC brake signal is held ON until either the RUN signal is removed or the DC brake signal is removed (OFF).

<b>b39 / b40 (option card)</b>	<b>S5 / S6 terminal MFIT Setting</b>
	<b>000: Run Forward</b>
	<b>001: Run Reverse</b>
	<b>002: Preset Speed Command 1</b>
	<b>003: Preset Speed Command 2</b>
	<b>004: Preset Speed Command 3</b>
	<b>005: Jog Frequency Command</b>
	<b>006: Emergency Stop (E.S.)</b>
	<b>007: Base Block (b.b.)</b>
	<b>008: Switching to 2<sup>nd</sup> acceleration/ deceleration time.</b>
	<b>009: Reset</b>
	<b>010: Up Command</b>
	<b>011: Down Command</b>
	<b>012: Control signal switch</b>
	<b>013: Communication control signal switch</b>
	<b>014: Acceleration/ deceleration disable</b>
	<b>015: Master/ auxiliary speed switch</b>
	<b>016: PID function disable</b>

Refer to b35 ~ b38

**b42 Frequency UP / DOWN control (Motorized pot):**

**000 : Set frequency by this function will be stored when the inverter stops.**

**UP/DOWN function is not available in stop mode.**

**001 : Set frequency will be reset to 0Hz when the inverter stops.**

**002 : Set frequency will be stored when the inverter stops.**

**UP/DOWN function is available in stop mode.**

- 1) **b42 = 000**, when a RUN command is ON, the *iDrive* will accelerate the motor to the frequency set in b45 then maintain running at this speed. When UP/DOWN terminal is ON, the *iDrive* begins to accelerate/decelerate the motor until the signal goes OFF then it runs at this new speed etc.

When the RUN goes OFF, the *iDrive* decelerates or coasts the motor to stop according to the setting of b92. The frequency at which the RUN signal is OFF will be stored in b45.

The UP/DOWN Key is not available at stop. The stored frequency cannot be changed by UP/DOWN terminal, but can by changing the value of b45.

- 2) **b42 = 001**, the *iDrive* will run from 0 Hz when run signal is applied. UP/DOWN operation method is same as b45 = 000, but when next RUN signal is ON, *iDrive* will start from 0Hz.
- 3) **b42 = 002**. Same as when b45 = 001 but UP/DOWN is available while in stop mode.

**b43: Multi-function input terminal S1~S6 signal scan time (N. mS × 8), N = (1~100 times).**

**b66: AIN signal scan time (N. mS × 8), N = (1~100 times).**

- 1.) If b43 scan time is set to say 80mS (i.e N = 10) then digital input signals on for less than 80mS will be ignored.
- 2.) If the CPU scans the same input signal for N times (scan times), it is accepted as normal. If it is less than N times, it will be taken as noise. One scan time: 8ms.
- 3.) User can increase the CPU scan time to counteract electromagnetic noise in the operating environment. Increasing b43/b66 will reduce the inverter response time.

#### **b44 – b52 Keypad, Jog and Preset Frequency setting**

Note 1: - Frequency selection will be made according to status of terminals S1-S4 & AIN and setting of parameters b35-b38 and b41 as required.

Note2:- Selected preset frequency values should be programmed into parameters b44 – b52 as required.

#### 1) **b35 ~ b38, and b41 = 002 - 004 (Preset Frequency Command 1~3)**

When a run command is applied and any of the selected multi-function input terminals are ON, the motor will run at the preset frequency according to the table below.

#### 2) **b35 ~ b38, and b41 = 005 (Jog Frequency Command)**

External input terminal is set to Jog operation. When terminal is ON, the motor will run at the Jog frequency according to the table below.

<b>Parameter</b>	<b>Description</b>	<b>Frequency range</b>	<b>Factory default</b>
b45	Preset frequency 1 (Hz)	00.0 - 200	05.0
b46	Preset frequency 2 (Hz)	00.0 - 200	05.0
b47	Preset frequency 3 (Hz)	00.0 - 200	10.0
b48	Preset frequency 4 (Hz)	00.0 - 200	20.0
b49	Preset frequency 5 (Hz)	00.0 - 200	30.0
b50	Preset frequency 6 (Hz)	00.0 - 200	40.0
b51	Preset frequency 7 (Hz)	00.0 - 200	50.0
b52	Preset frequency 8 (Hz)	00.0 - 200	60.0
b44	Jog frequency (Hz)	00.0 - 200	05.0

#### **b53 Multi-function analog output:**

**Multi-function analog output signal select:-**

**001: Set / command frequency**

**002: Output frequency**

**003: DC link voltage**

**004: Output current**

**005: PID feedback signal**

**b54 Multi-function analog output gain = 000 ~ 200%**

0-10 Vdc is output from multi-function analog output terminal FM+.

Output can be set to correspond to any of the above values.

b54 is used to scale the output signal supplied to an externally connected analog device.

b53 = 005, PID Feedback. The analog input to terminal AIN (0-10Vdc or 4-20mA) will be output from terminal FM+ as 0-10Vdc.

Note: Due to hardware limits, the max output voltage from FM+ terminal is limited to 10V.



**b55 Multi-function output RY1**  
**000: Inverter output on - RUN**  
**001: Frequency reached (Preset target frequency  $\pm$  b57)**  
**002: Frequency reached (Preset output frequency level (b56)  $\pm$ b57)**  
**003: Frequency Detection ( $>$ b56)**  
**004: Frequency Detection ( $<$ b57)**  
**005: Fault output**  
**006: Auto restart**  
**007: Momentary power loss**  
**008: Emergency Stop (E.S.)**  
**009: Base Block (b.b.)**  
**010: Motor overload protection**  
**011: Inverter overload protection**  
**012: xxx Not used xxx**  
**013: Power On**  
**014: Communication error**  
**015: Output current detection**  
**b56 Preset Output frequency reached = 00.0 ~ 200Hz**  
**b57 Frequency detection range = 00.0 ~ 30Hz**

**b55 (b60) = 001: Frequency Reached: Target frequency  $\pm$  b57**

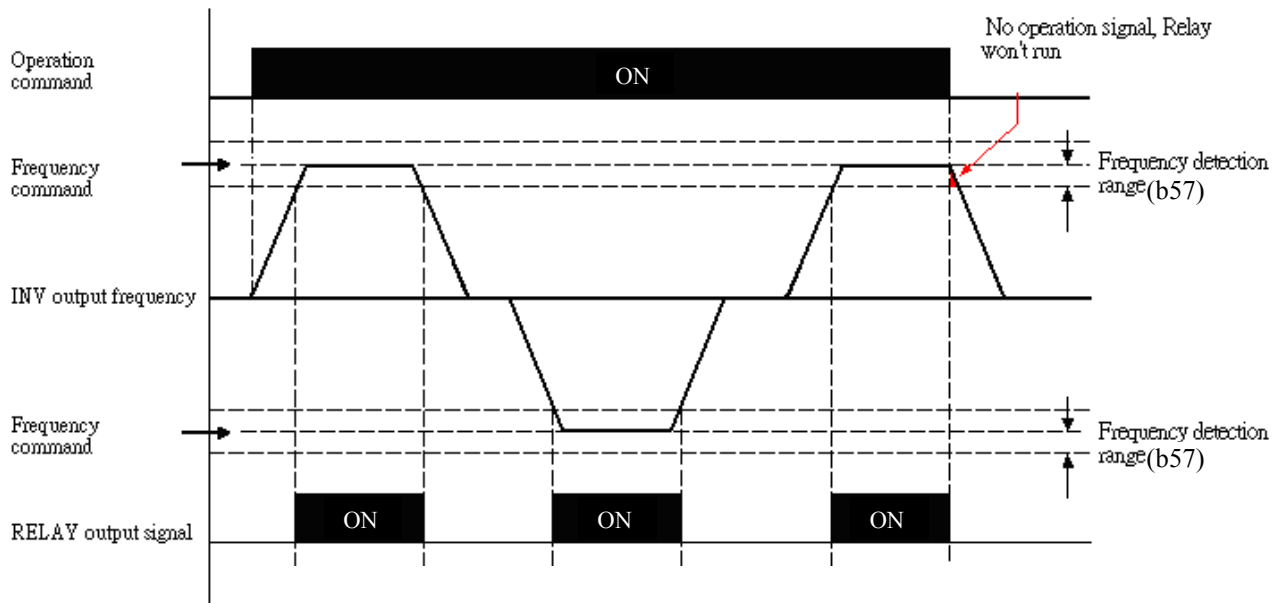

**b55 / b60 = 002 Preset Output Frequency b56 ± b57 Reached.**

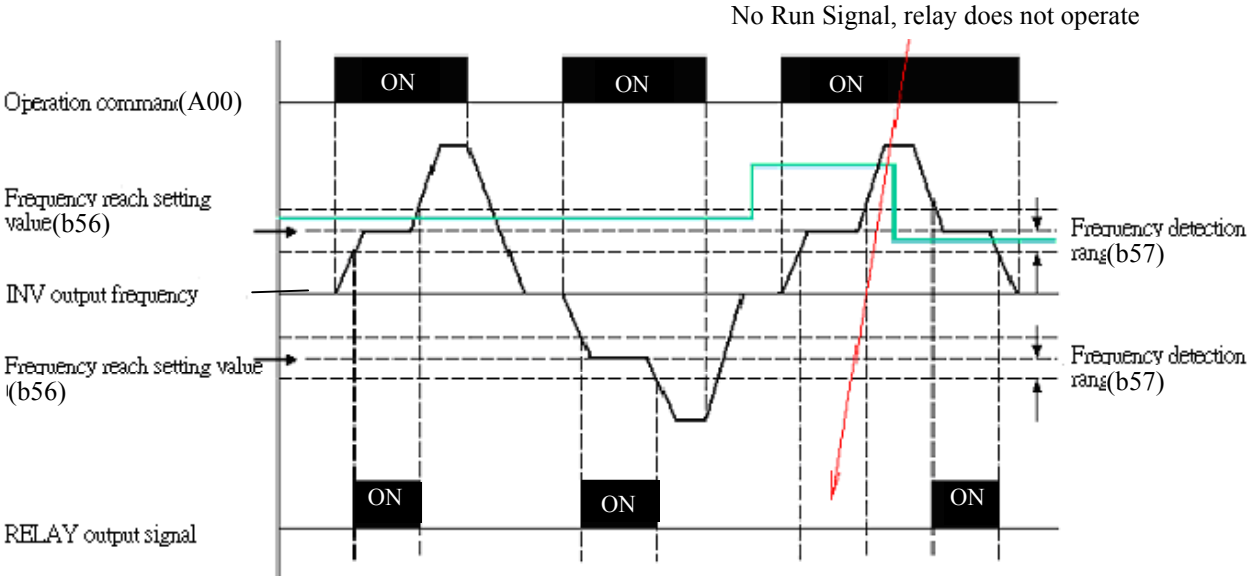

**b55 / b60 = 003: Frequency Detection  $F_{out} > b56$**

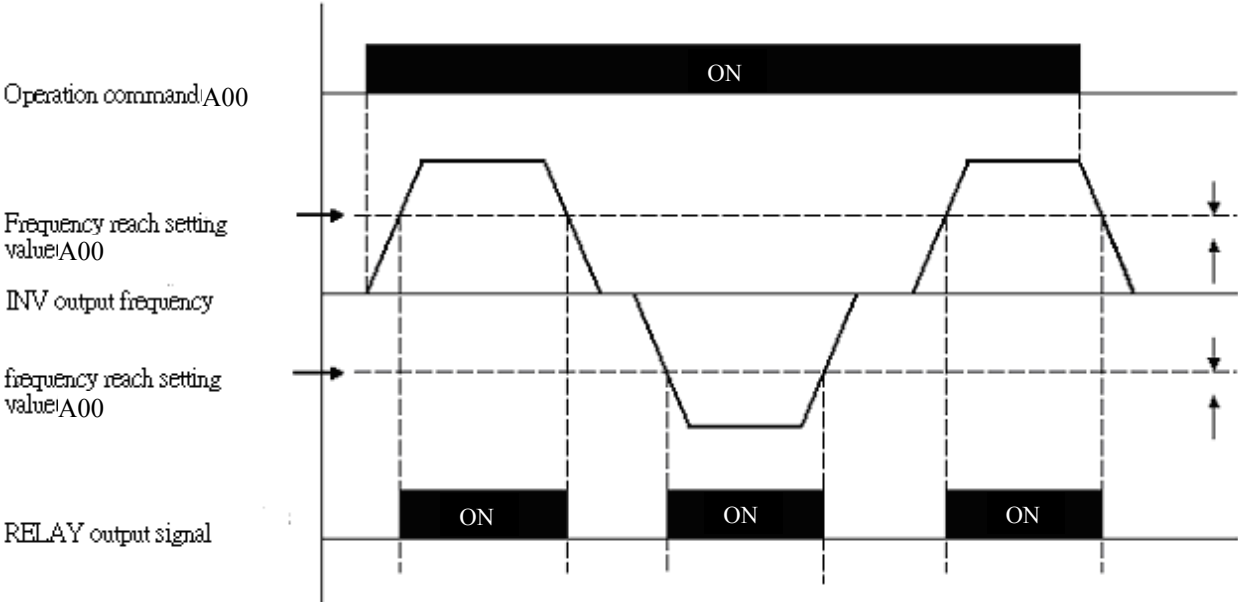

**b55 / b56 = 004: Frequency Detection  $F_{out} < b56$**

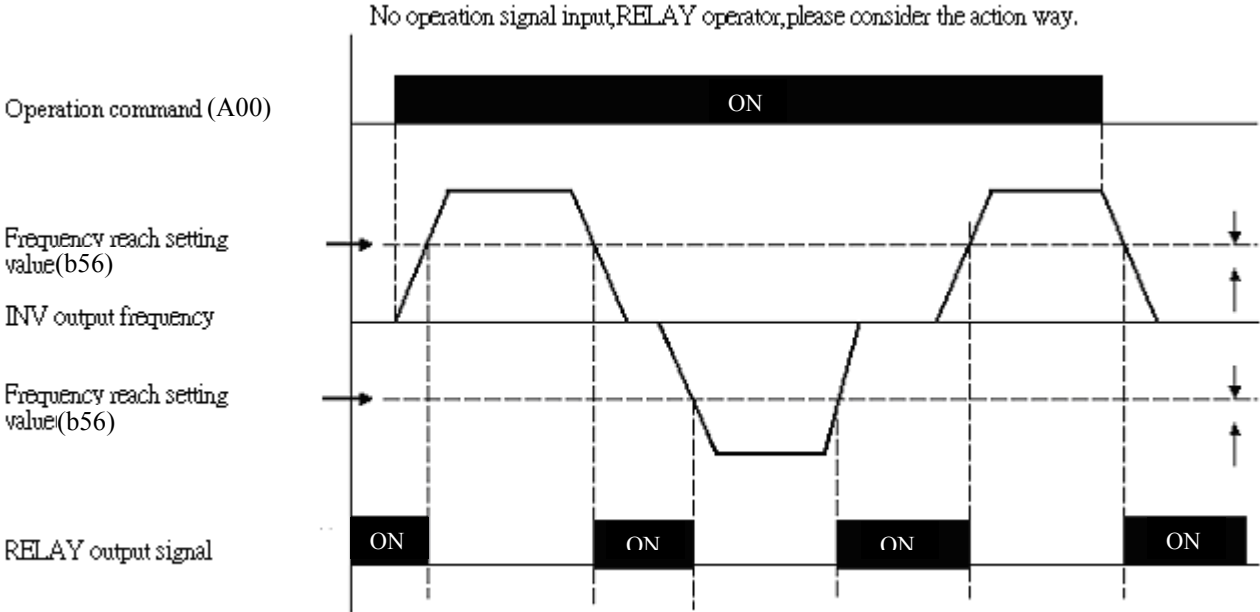

**b58 Output Current reached set value**

**b59 Output Current detection time**

- b55: Output current detection value > b58
  - b60: Output current detection value > b58
  - b58: Set value (000-100%) of motor rated current b09
  - b59: Set value (00.0-25.5s)
- } When set value is 015

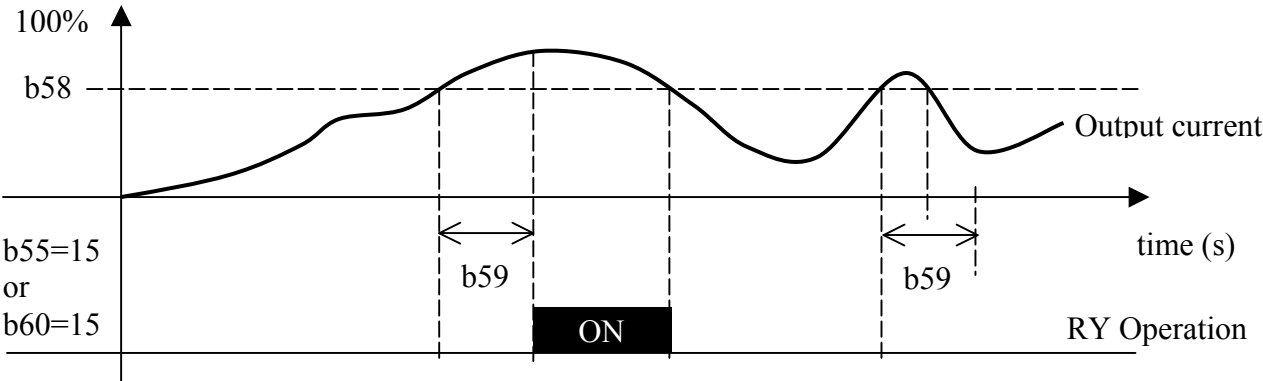

**b60 Multi-function output transistor ~ (terminals T+, T- Option card)**  
**000: Inverter output on - RUN**  
**001: Frequency reached (Preset target frequency  $\pm$  b57)**  
**002: Frequency reached (Preset output frequency level (b56)  $\pm$ b57)**  
**003: Frequency Detection (>b56)**  
**004: Frequency Detection (<b57)**  
**005: Fault output**  
**006: Auto restart**  
**007: Momentary power loss**  
**008: Emergency Stop (E.S.)**  
**009: Base Block (b.b.)**  
**010: Motor overload protection**  
**011: Inverter overload protection**  
**012: xxx Not used xxx**  
**013: Power On**  
**014: Communication error**  
**015: Output current detection**

**Note: Frequency priority: Jog  $\rightarrow$  Preset frequency  $\rightarrow$  External analog frequency signal**

Refer to parameter b55 description for more details.

**b61 AIN signal select**  
**000: 0~10V/0~20mA**  
**001: 2~10V/4~20mA**

Note: Switch SW2 (V/I signal select) on *iDrive* control board must be set to required position

b61 = 000: 0~10V/0~20mA

b61 = 001: 2~10V/4~20mA

**b62 AIN Gain (%) 000 - 200**  
**b63 AIN Bias (%) 000 - 100**

- 1) b64 = 000: 0V (4mA) corresponds to lower frequency limit, 10V (20mA) corresponds to upper frequency limit.
- 2) b64 = 001: 10V (20mA) corresponds to lower frequency limit, 0V (4mA) corresponding to upper frequency limit.

Fig (1) example settings below:

	b62	b63	b64	b65
A	100%	050%	000	000
B	100%	000%	000	000

Fig (2) example settings below:

	b62	b63	b64	b65
C	100%	050%	000	001
D	100%	000%	000	001

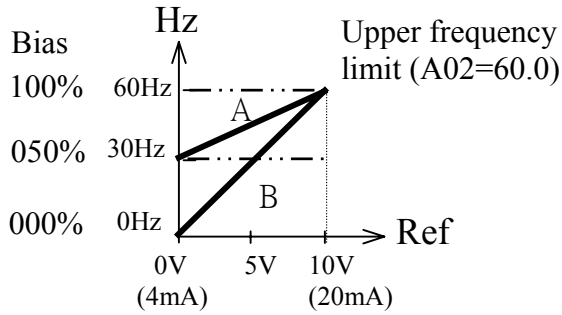

Fig (1)

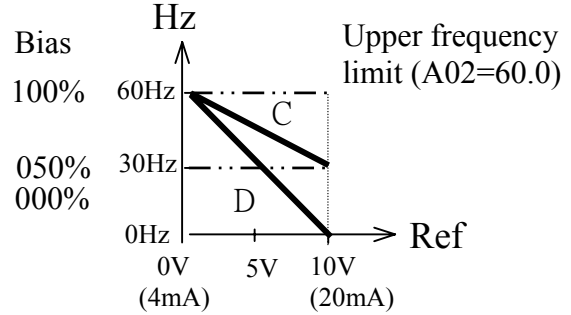

Fig (2)

Fig (3) example settings below:

	b62	b63	b64	b65
E	100%	020%	001	000

Fig (4) example settings below:

	b62	b63	b64	b65
F	100%	100%	001	001

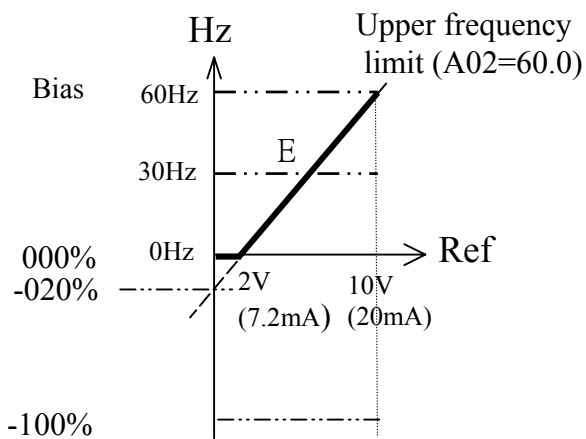

Fig (3)

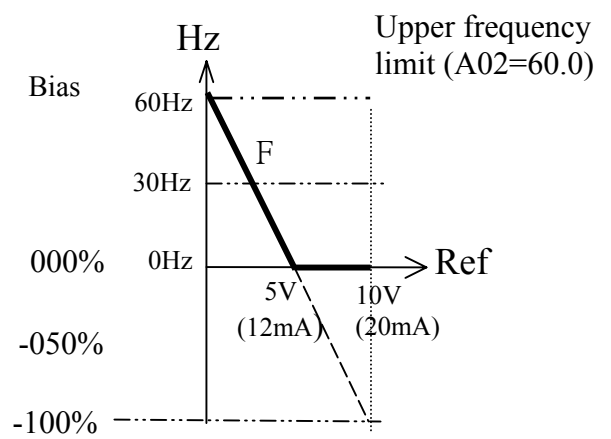

Fig (4)

Note: 'Ref' = Analogue frequency reference signal V or I

<b>b64 AIN Bias:</b>	<b>000: Positive</b>	<b>001: Negative</b>
<b>b65 AIN Signal Slope direction.</b>	<b>000: Positive</b>	<b>001: Negative</b>
<b>b66 AIN signal scan time confirmation.</b>	<b>(mSec × 8): 001 – 100</b>	

Refer to b62/b63 description

The *iDrive* reads A/D average value every  $b66 \times 8mS$ . The user can set scan interval time according to noise in the operation environment. Increase value of b66 if electromagnetic noise is a problem but note that the inverter response time will be slower.

**b67 PID operation mode****000: PID Function disabled.****001: PID Control, deviation is derivative controlled****002: PID Control, feedback is derivative controlled.****003: Same as 001 but (reverse characteristics control).****004: Same as 002 but (reverse characteristics control).**

b67 = 001, D is the deviation from (target value – feedback value) in the unit time (b71).

= 002, D is the deviation of feedback value in the unit time (b71).

= 003, D is the deviation of (target value – feedback value) in the unit time (b71).

If the deviation is positive, the output frequency decreases, vice versa.

= 004, D is the deviation of feedback value in unit time (b71).

When the deviation is positive, the output frequency decreases, vice versa.

**b68 Feedback gain : 0.00 - 10.0**

b68 is feedback gain, ie feedback value = detected value × b68.

**b69 P: Proportional gain : 0.00 - 10.0**

b69: Proportional gain for P control.

**b70 I: Integral time (s) : 00.0 - 100**

b70: Integral time for I control

**b71 D: Differential time (s) : 0.00 - 10.0**

b71: Differential time for D control.

**b72 PID offset****000: Positive direction****001: Negative direction****b73 PID offset adjust (%) : 000 ~ 109%**

PID operation result can be adjusted by b73 (b72 effects the polarity of b73).

### b74 PID update time (s) : 00.0 - 02.5

b74: the refresh time of PID output command.

**Note: PID function is used in flow control, fan air volume control and temperature control.  
Control flow diagram below:**

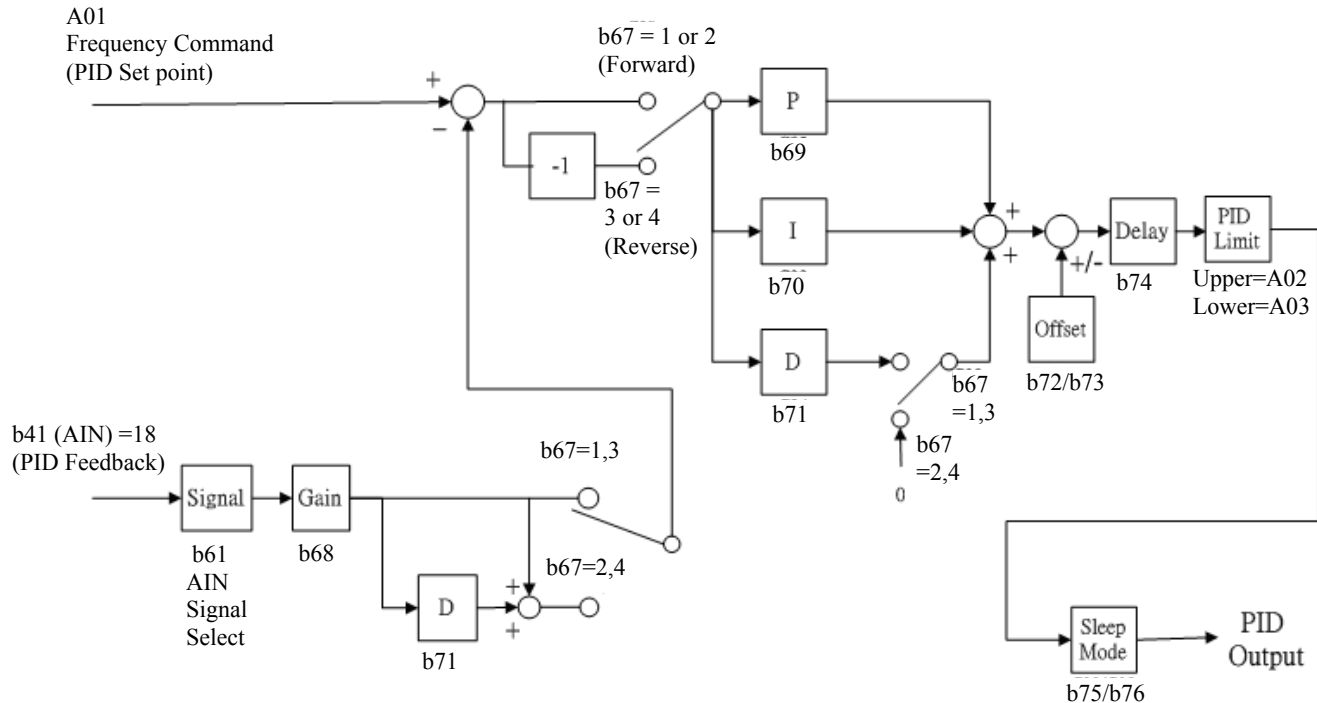

1. In PID mode, select AIN on TM2 as PID feedback signal, Set b41 = 018.
2. The PID set-point control input is set by parameter A01 (selections 000 & 001).  
This value is stored in b45.

### b75 PID Sleep frequency (Hz) 00.0~200Hz

### b76 PID Sleep delay time (sec) 00.0~25.5sec

PID sleep mode can be set by using function codes below: -

- b67 = 001~004 (PID Enable)
- b41 = 018 (AIN is PID feedback signal)
- b45 = PID preset frequency
- b75 = sleep start frequency, (Hz)
- b76 = PID sleep delay time, (s)

When PID output frequency becomes lower than PID sleep start frequency (b75) for a period of time (b76), the *iDrive* output will decelerate to zero speed (Sleep mode). When the PID output frequency becomes higher than the sleep start frequency (b75), the *iDrive* output accelerates to PID output frequency (Wake-up mode).

Sleep-mode; Typical example:

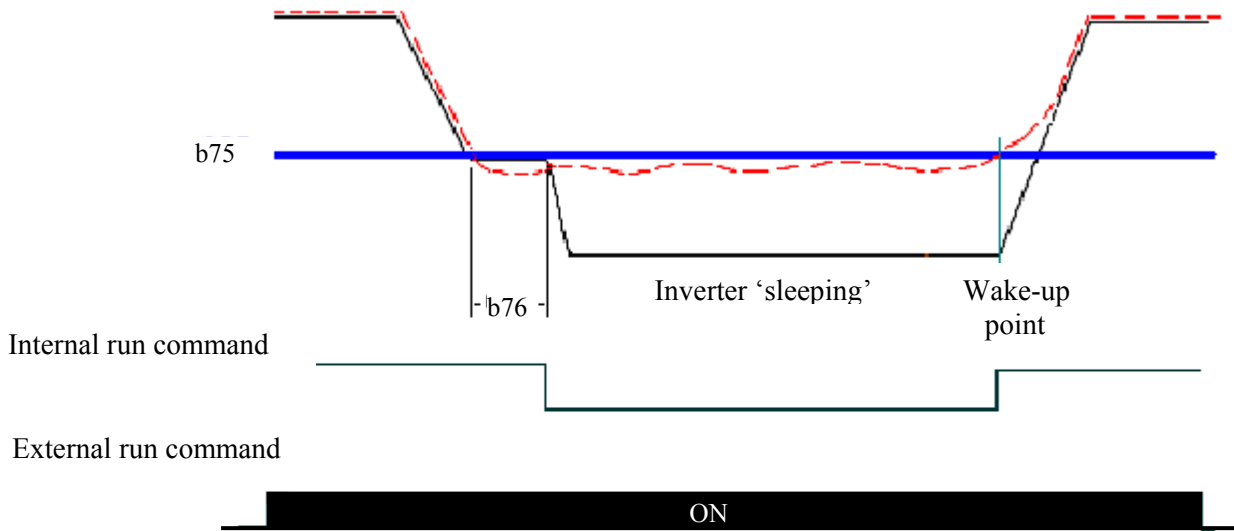

- *iDrive* output frequency
- - - PID output
- Sleep frequency (b75)

b75: Sleep level  
b76: Sleep delay

<b>b77 Inverter Communication Address:</b>	<b>001~ 254</b>
--	-----------------

b77 sets the communication address for a specific inverter when multi-inverters are controlled by serial communication method.

<b>b78 Baud Rate (bps)</b>	<b>000: 4800</b> <b>001: 9600</b> <b>002: 19200</b> <b>003: 38400</b>
----------------------------	--

<b>b79 Stop bit</b>	<b>000: 1 Stop bit</b> <b>001: 2 Stop bit</b>
---------------------	--

<b>b80 Parity bit</b>	<b>000: No parity</b> <b>001: Even parity</b> <b>002: Odd parity</b>
-----------------------	--

<b>b81 Data bits</b>	<b>000: 8 bits data</b> <b>001: 7 bits data</b>
----------------------	--



**1. RS-485 communication:** (requires RS485 option card)(Option)

**1 to 1 control:** PC, PLC or other device can control one *iDrive* on the communication link at any given time. Each *iDrive* requires that b77 is set between 001~254. Only the *iDrive* with the correct address will reply to the master with an Acknowledge/Not Acknowledge message.

**1 to many control:** PC, PLC or other device can send a 'broadcast' message to all *iDrive*'s on the communication link by sending to address 000. In this transmission mode all of the connected *iDrive*'s each receive the same command (regardless of setting b77 on each *iDrive*) but do not reply to the master.

**2. RS-232 communication:** (requires RS232 port device)(Option)

1 to 1 control: PC or PLC or controller controls one inverter (b77 is set to 001~254).

- ※**Note:**
- a. The baud rate (b78) and communication format (b79/b80/b81) of PC (or PLC or other controller) and *iDrive* should be the same.
  - b. The *iDrive* will validate any modified parameters after the parameters are modified by PLC or PC etc.
  - c. Communication protocol: refer to EDX communication protocol description.
  - d. Parameters b77~b81 cannot be changed in communication mode.

**b82 Communication error detection time (s)****b83 Communication error – inverter response**

- (1) Time-out detection time: 00.0~25.5sec; setting 00.0 sec: disable time-out function.

Default = 00.0sec

\*Cannot be changed in communication mode.

- (2) Time-out operation selection:

000 : Deceleration to stop (A05 : Deceleration time 1).

001 : Coast-to-stop.

002 : Deceleration to stop (b01 : Deceleration time 2).

003 : Continue operating (Ignore error).

Default = 000

\*Cannot be changed in communication mode.

See Communication error timing diagram following.

b82/b83 Communication error timing diagram

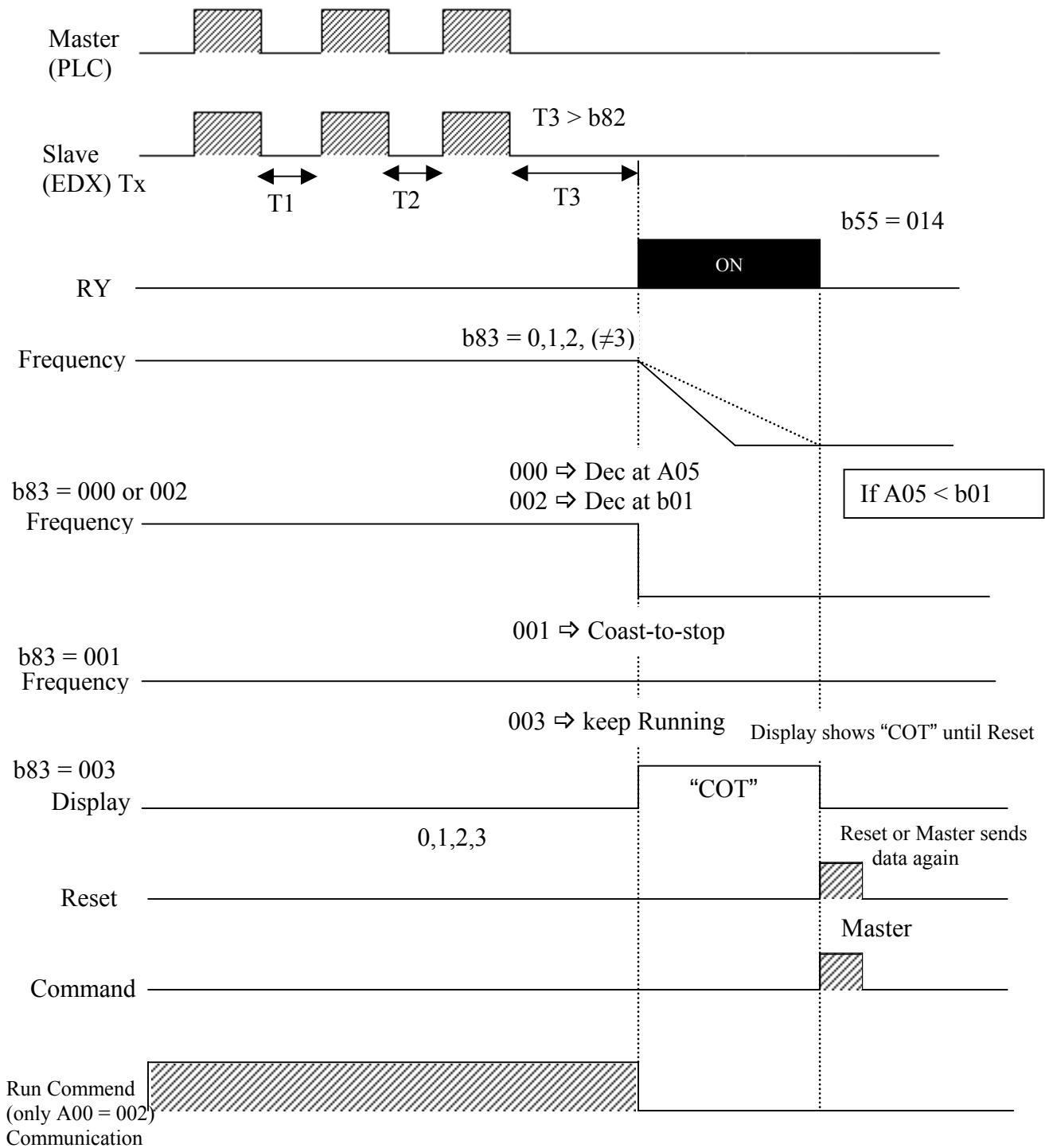

**b84 Local / Remote control select**

• **Local mode**

Run command

Only Run/Stop on the keypad can control ON / OFF and the setting of A00 has no relationship.

Frequency command

When b84 = 000: only UP/DOWN on the keypad can control and the setting of A01 has no relationship.

When b84 = 001: only VR on the keypad can control and the setting of A01 has no relationship.

- **Remote mode**

Run command from the run parameter A00

Frequency command from the frequency parameter A01

**Tip!**

Quick changeover between **LOCAL** and **REMOTE** control modes can be made by simultaneously pressing the ▼/RESET and the DATA/ENT keys on keypad. Modes can be 'toggled' by this method. Note that the motor must be stopped before changeover is allowed.

<b>b85 Remote keypad control</b>	<b>000: Disabled</b> <b>001: Enabled: Operation according to b92 if cable fault</b> <b>002: Enabled: Operation at the last set frequency if cable fault</b> (Stop mode by <i>iDrive</i> Keypad or parameter A00 as appropriate).
----------------------------------	---

When b85 = 001, the following parameters will be auto set:

<i>iDrive</i> serial communication address: = 1	Data bits: 8 bit
Baud rated (bps): 38400	Parity: no parity
Stop bits: 1 bit	

**Note: 1. Connect remote keypad in stop mode; control priority is with remote keypad**  
**2. If the remote keypad is connected in run mode, it will not be effective until the inverter is in stop mode.**

<b>b86 Carrier frequency (kHz) : 004-016</b> <b>Set this parameter from 4-16kHz as required. (Default = 10 kHz).</b>
---

**Note: In situations where there is excessive audible noise from the motor or it is required to reduce electrical interference (RFI) from the inverter caused by use of long cable then the carrier frequency can be adjusted.**

- To reduce electromagnetic interference due to long cable etc, decrease carrier frequency.
- To reduce motor audible noise, increase carrier frequency.

b86	Carrier frequency	b86	Carrier frequency	b86	Carrier frequency	b86	Carrier frequency
004	4kHz	008	8kHz	012	12kHz	016	16kHz
005	5kHz	009	9kHz	013	13kHz		
006	6kHz	010	10kHz	014	14kHz		
007	7kHz	011	11kHz	015	15kHz		

**Note: If the carrier frequency is increased the output current from the inverter must be de-rated according to the following table.**

**Output current (A) derating with increasing carrier frequency**

EDX- Carrier frequency	020-11, 020-21, 020-23	040-11, 040-21, 040-23	075-11, 075-21, 075-23	150-21, 150-23	220-21, 220-23	075-43	150-43	220-43
4~10kHz	1.7	3.1	4.2	7.5	10.5	2.3	3.8	5.2
12kHz	1.7	3.1	4.2	7.5	10.5			
14kHz	1.6	3.0	4.0	7.0	10			
16kHz	1.5	2.8	3.8	6.8	9.8			

**b87 Cooling fan control**    **000: Auto-run by inverter temperature**  
**001: Run when inverter output is ON**  
**002: Always running.**  
**003: Always stopped.**

- 1.) b87 = 000: The fan is thermostatically controlled in order to extend the life of the fan.
- 2.) b87 = 001: The fan runs when the *iDrive* output is ON.
- 3.) b87 = 002: The fan runs when power supply is ON (*iDrive* output OFF or ON).
- 3.) b87 = 003: The fan does not run at any time (**care needed as damage to *iDrive* could occur!**)

**b88 Motor rotating direction**    **000: Forward**  
**001: Reverse**

Only when A00 = 000 (*iDrive* operation is controlled by Keypad).

**b89 Inverter capacity code (Input voltage – Output HP/kW)**

b89 code	<i>iDrive</i> rated V & HP / kW
1P2	110V - 0.25 / 0.18
1P5	110V - 0.5 / 0.37
101	110V - 1 / 0.75
2P2	220V – 0.25 / 0.18
2P5	220V - 0.5 / 0.37
201	220V - 1 / 0.75
202	220V – 2 / 1.5
203	220V – 3 / 2.2
401	400V – 1 / 0.75
402	400V – 2 / 1.5
403	400V – 3 / 2.2

Examples:

2P5 =  
*iDrive* 220V input / 0.5HP (0.37kW) rated output power

402 =  
*iDrive* 400V input / 2.0HP (1.5kW) rated output power

**b90 : External control operation mode 000: Forward/ Stop-Reverse/Stop**  
**001: Run/ Stop-Forward/Reverse**  
**002: 3-wire—Run/ Stop**

- 1.) b90 is only available when A00 = 001 (control from terminals TM2).
- 2.) When both forward and reverse commands are ON, output is stopped.

Parameter b90 = 000

(1). NPN input signal:

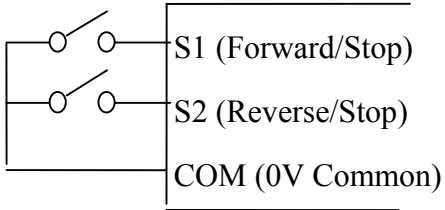

(2). PNP input signal:

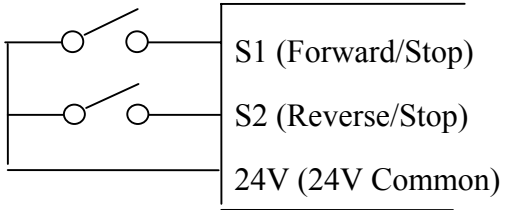

Parameter b90 = 001

(1). NPN input signal:

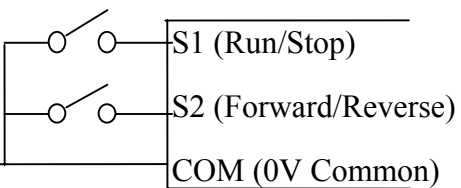

(2). PNP input signal:

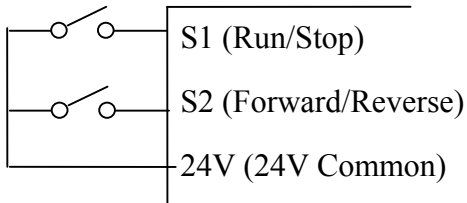

Parameter b90 = 002

(1). NPN input signal:

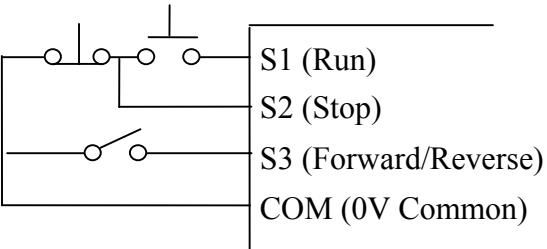

(2). PNP input signal:

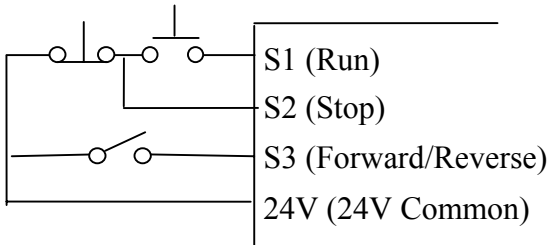

**Note:- In 3 wire control mode terminals S1-S3 are used , therefore parameters b35 ~ b37 are ineffective.**

## Parameter b90 timing and operation diagram



**Note: If b91 = 001, reverse command is disabled.**

<b>b91 Reverse run</b>	<b>000: Reverse enable</b> <b>001: Reverse disable</b>
------------------------	---

A00 = 000 and b91 = 001, b88 (motor direction) disabled, the *iDrive* is set to forward operation.  
A00 = 001 or 002, and b91 = 001, reverse command is disable.

<b>b92 Stopping method</b>	<b>000: Decelerate to stop</b> <b>001: Free run (Coast) to stop</b>
----------------------------	--

- 1.) b92 = 000: after receiving stop command, the motor will decelerate (ramp) to stop according to setting of A05.
- 2.) b92 = 001: after receiving stop command, the motor will free-run (coast) to stop.

<b>b93 Status monitoring display</b>	<b>000: Disable</b> <b>001: Enable.</b>
--------------------------------------	--

b93 = 001 display shows Output Frequency, Motor Current, Output Voltage, DC Link Voltage, or PID feedback.

<b>b94 Copy module</b>	<b>000: Copy module Disabled</b> <b>001: Copy to module from <i>iDrive</i> (Read)</b> <b>002: Copy to <i>iDrive</i> from module (Write)</b> <b>003: Read / write check (Compare parameters).</b>
------------------------	---

Note: Parameter copy facility is applicable only to *iDrives* with the same voltage and kW capacity.

**b95 Factory default****010: Reset all parameters to factory default (50Hz)****020: Reset all parameters to factory default (60Hz)****b96 Software version****Displays inverter software version (Read only)****b97 Fault / Alarm log (last 3 alarms) – (read only)**

## Chapter 5 Troubleshooting and Maintenance

### 5.1 Fault indication and remedy

#### 5.1.1 Fault / Error display and Diagnostics

##### 1. Non-resetable errors

Display	Error	Cause	Remedy
<b>EPR</b>	Memory problem	EEPROM fault	Contact your supplier
@ <b>OU</b>	Over voltage during stopping	Detection circuit malfunction	Contact your supplier
@ <b>LU</b>	Under voltage	<ol style="list-style-type: none"> <li>1. Power voltage too low</li> <li>2. Supply fuse blown.</li> <li>3. Detection circuit malfunction</li> </ol>	<ol style="list-style-type: none"> <li>1. Check if the power voltage is correct</li> <li>2. Replace the fuse</li> <li>3. Contact your supplier</li> </ol>
@ <b>OH</b>	The inverter has overheated	<ol style="list-style-type: none"> <li>1. Detection circuit malfunction</li> <li>2. Ambient temperature too high or poor ventilation</li> </ol>	<ol style="list-style-type: none"> <li>1. Improve ventilation conditions</li> <li>2. Contact your supplier</li> </ol>
<b>CTR</b>	Current transducer detection error	Current transducer or circuit error.	Contact your supplier

Note : “@” Alarm relay contacts do not operate.



## 1. Errors which can be reset manually and automatically

Display	Error	Cause	Remedy
<b>OCS</b>	Over-current at start-up	<ol style="list-style-type: none"> <li>1. The motor winding and frame short circuit</li> <li>2. Motor cable ground fault</li> <li>3. Power module is damaged</li> </ol>	<ol style="list-style-type: none"> <li>1. Check the motor</li> <li>2. Check the motor wiring</li> <li>3. Contact your supplier</li> </ol>
<b>OCD</b>	Over-current at deceleration	Deceleration time is too short	Set a longer deceleration time
<b>OCA</b>	Over-current at acceleration	<ol style="list-style-type: none"> <li>1. Acceleration time is too short</li> <li>2. The capacity of the motor higher than the capacity of the inverter</li> <li>3. Short circuit between the motor winding and frame.</li> <li>4. Short circuit between motor wiring and earth</li> <li>5. IGBT module is damaged</li> </ol>	<ol style="list-style-type: none"> <li>1. Set a longer acceleration time</li> <li>2. Replace inverter with the same capacity as that of the motor</li> <li>3. Check the motor windings</li> <li>4. Check the motor wiring</li> <li>5. Contact your supplier</li> </ol>
<b>OCC</b>	Over-current during running	<ol style="list-style-type: none"> <li>1. Transient load change</li> <li>2. Transient power change</li> <li>3. Motor or wiring fault</li> </ol>	<ol style="list-style-type: none"> <li>1/2. Increase <i>iDrive</i> capacity</li> <li>3. Check the motor &amp; wiring</li> </ol>
<b>OUC</b>	Over voltage during operation/ deceleration	<ol style="list-style-type: none"> <li>1. Deceleration time setting is too short or large load inertia</li> <li>2. Power voltage varies widely</li> </ol>	<ol style="list-style-type: none"> <li>1. Set a longer deceleration time</li> <li>2. Connect a brake module &amp; suitable braking resistor</li> <li>3. Use an ACR reactor on the power input side</li> <li>4. Increase <i>iDrive</i> capacity</li> </ol>
<b>OHC</b>	High heat sink temperature during operation	<ol style="list-style-type: none"> <li>1. Heavy load</li> <li>2. Ambient temperature too high or poor ventilation</li> </ol>	<ol style="list-style-type: none"> <li>1. Check if there are any problems with the load</li> <li>2. Increase <i>iDrive</i> capacity</li> <li>3. Improve ventilation conditions</li> <li>4. Check <i>iDrive</i> cooling fan is operating (if fitted)</li> <li>5. Check the setting value of parameter b87</li> </ol>

## 3. Errors which can only be recovered manually but cannot be auto-recovered

Display	Error	Cause	Remedy
<b>OC</b>	Over-current during stopping	<ol style="list-style-type: none"> <li>1. Detection circuit malfunction</li> <li>2. Poor connection on CT signal cable</li> </ol>	Contact your supplier
<b>OL1</b>	Motor overload	<ol style="list-style-type: none"> <li>1. Heavy load</li> <li>2. Incorrect setting of b09</li> </ol>	<ol style="list-style-type: none"> <li>1. Increase motor and <i>iDrive</i> capacity</li> <li>2. Set b09 correctly according to motor nameplate.</li> </ol>
<b>OL2</b>	Inverter overload	Load too big on <i>iDrive</i>	Increase <i>iDrive</i> capacity or reduce load
<b>OCL</b>	Over-current limit	<ol style="list-style-type: none"> <li>1. Heavy Load</li> <li>2. Continuous over load</li> <li>3. Shock Load</li> <li>4. Instantaneous over-current due to motor or wiring fault</li> </ol>	<ol style="list-style-type: none"> <li>1. Increase motor capacity</li> <li>2. Increase ACC/ DEC time A04 ~ A05, etc</li> <li>3. Set stall prevention function b23 ~ b29</li> <li>4. Check motor &amp; wiring</li> </ol>
<b>LUC</b>	Under voltage during operation	<ol style="list-style-type: none"> <li>1. Power voltage too low</li> <li>2. Power voltage momentary dip</li> </ol>	<ol style="list-style-type: none"> <li>1. Check input voltage</li> <li>2. Use an ACR on the power input side &amp; record input voltage over time period</li> <li>3. Increase <i>iDrive</i> capacity</li> </ol>

## 5.1.2 Set up &amp; Interface Errors.

Display	Error	Description
<b>SP0</b>	Zero speed stop	Displayed when set frequency <0.1Hz Increase frequency reference signal.
<b>SP1</b>	Fail to start directly	<ol style="list-style-type: none"> <li>1. If the <i>iDrive</i> is set to external control mode (A00 = 001), and direct start is disabled (b33=001), the <i>iDrive</i> cannot be started and will flash STP1 when Run command in ON when power is applied (see descriptions of b33).</li> <li>2. Direct start is possible when b33 = 000.</li> </ol>
<b>SP2</b>	Keypad emergency stop	<ol style="list-style-type: none"> <li>1. If the <i>iDrive</i> is set to external control mode (A00=001) the <i>iDrive</i> will stop according to the setting of b92 when stop key is pressed. STP2 flashes after stop. Turn the Run switch to OFF and then ON again to restart the <i>iDrive</i>.</li> <li>2.If the <i>iDrive</i> is in communication mode and Stop key is enabled, the <i>iDrive</i> will stop as set by b92 when Stop key is pressed during operation and then flashes STP2.</li> </ol> <p>The PLC must send a Stop command followed by a Run command to the <i>iDrive</i> for it to be restarted.</p>
<b>E.S.</b>	External emergency stop	The <i>iDrive</i> will decelerate to stop and then flashes E.S. when there is an external emergency stop signal via the multi-function input terminals (see descriptions of b35 ~ b38).
<b>b.b.</b>	External base block	The <i>iDrive</i> stops immediately and then flashes b.b. when external base block is input through the multi-functional input terminal (see descriptions of b35 ~ b38).
<b>PID</b>	PID feedback signal fault	PID feedback signal circuit error detection
<b>---</b>	REMOTE KEYPAD cable broken	<ol style="list-style-type: none"> <li>1. REMOTE KEYPAD is not connected with inverter, such a display will occur.</li> <li>2. REMOTE KEYPAD and main KEYPAD both display such signal means a communication error.</li> </ol> <p>Note: It is normal for the main <i>iDrive</i> keypad to display this code when the REMOTE KEYPAD is connected and functioning normally</p>

## 5.1.3 Keypad operation error description

Display	Error	Cause	Remedy
<b>Er1</b>	Key operation error	<ol style="list-style-type: none"> <li>1. Press ▲ or ▼ keys when A01 &gt; 0 or in speed operation.</li> <li>2. Attempt to modify parameters, which cannot be modified during Run (see parameter list).</li> </ol>	<ol style="list-style-type: none"> <li>1. ▲ or ▼ keys can be used to modify frequencies only when A01 = 0.</li> <li>2. Modify them after Stop.</li> </ol>
<b>Er2</b>	Parameter setting error	<ol style="list-style-type: none"> <li>1. A02 is in ranges of b20±b22 or b21±b22</li> <li>2. A02 &lt; A03</li> </ol>	<ol style="list-style-type: none"> <li>1. Change A02 value</li> <li>2. Make A02 &gt; A03</li> </ol>
<b>Er5</b>	Modification of parameter is not allowed during communication	<ol style="list-style-type: none"> <li>1. Control command given when communications are disabled</li> <li>2. Attempt to modify b77 ~ b81 during communication.</li> </ol>	Set up parameters before communication begins.
<b>Er6</b>	Communication failure	<ol style="list-style-type: none"> <li>1. Incorrect cabling.</li> <li>2. Incorrect settings of communication parameters.</li> <li>3. Check sum error.</li> <li>4. Incorrect communication program.</li> </ol>	<ol style="list-style-type: none"> <li>1. Check connections.</li> <li>2. Check b77 ~ b81</li> </ol>
<b>Er7</b>	Incorrect parameter settings	<ol style="list-style-type: none"> <li>1. Attempt to modify b89</li> <li>2. Voltage and current detection circuits work abnormally.</li> </ol>	<ol style="list-style-type: none"> <li>1. Reset <i>iDrive</i>.</li> <li>2. If not possible contact your supplier</li> </ol>
<b>EP1</b>	Parameter set error, Copy Unit failure	<ol style="list-style-type: none"> <li>1. If b94 = 1 or 2, and cannot connect with Copy Unit.</li> <li>2. Copy Unit failure.</li> <li>3. The voltage and capacity parameter of Copy Unit &amp; the <i>iDrive</i> are different.</li> </ol>	<ol style="list-style-type: none"> <li>1. Modify b94</li> <li>2. Change Copy Unit</li> <li>3. Copy the same <i>iDrive</i> parameter for voltage and capacity, then WRITE.</li> </ol>
<b>EP2</b>	Parameters do not match	When copying parameters to <i>iDrive</i> – verification code that parameters do not match.	<ol style="list-style-type: none"> <li>1. Change Copy Unit</li> <li>2. The voltage and capacity parameter in Copy Unit are different to <i>iDrive</i></li> </ol>

## 5.2 General functional troubleshooting

Status	Checking point	Remedy
Motor can not run	Is power applied to L1, L2, and L3(N) terminals (is the charging indicator lit)?	<input type="checkbox"/> Is the power applied? <input type="checkbox"/> Turn the power OFF and then ON again. <input type="checkbox"/> Make sure the power voltage is correct. <input type="checkbox"/> Make sure terminals are fully tightened.
	Is there voltage output at T1, T2, and T3 terminals?	<input type="checkbox"/> Turn the power OFF and then ON again.
	Is the motor mechanically overloaded?	<input type="checkbox"/> Reduce the load to allow the motor to rotate.
	Are there any abnormalities in the inverter?	See error descriptions to check wiring and correct if necessary.
	Is forward or reverse run command issued?	
	Is there an analog input signal?	<ul style="list-style-type: none"> <li>• Is analog frequency input signal wiring correct?</li> </ul> <input type="checkbox"/> Is voltage of frequency input correct?
Is operation mode setting correct?	• Check parameter setting	
Motor runs in wrong direction	Is output wiring on terminals T1, T2, and T3 correct?	<input type="checkbox"/> Wiring must match U, V, and W terminals of the motor.
	Is wiring for forward and reverse signals correct?	<input type="checkbox"/> Check wiring is correct if necessary.
The motor speed can not vary	Are wiring for output terminals T1, T2, and T3 correct?	<input type="checkbox"/> Check wiring is correct if necessary.
	Is the setting of frequency command source correct?	<input type="checkbox"/> Check the operation mode setting at the keypad.
	Is the mechanical load too heavy?	<input type="checkbox"/> Reduce load.
Motor running speed too high or too low	Is the setting of operation mode correct?	<input type="checkbox"/> Confirm the motor's specifications.
	Is the load too heavy?	<input type="checkbox"/> Confirm the gear ratio.
	Are specifications of the motor (poles, voltage...) correct?	<input type="checkbox"/> Confirm the highest output frequency.
Motor speed varies unusually	Is the gear ratio correct?	<input type="checkbox"/> Reduce the load.
	Is the setting of the highest output frequency correct?	<input type="checkbox"/> Minimize the variation of the load. <input type="checkbox"/> Increase capacities of the inverter and the motor.
	Is the load too heavy?	<input type="checkbox"/> Add an AC reactor at the power input side if using single-phase power. <input type="checkbox"/> Check wiring if using three-phase power.

### 5.3 *iDrive* Troubleshooting Flowcharts

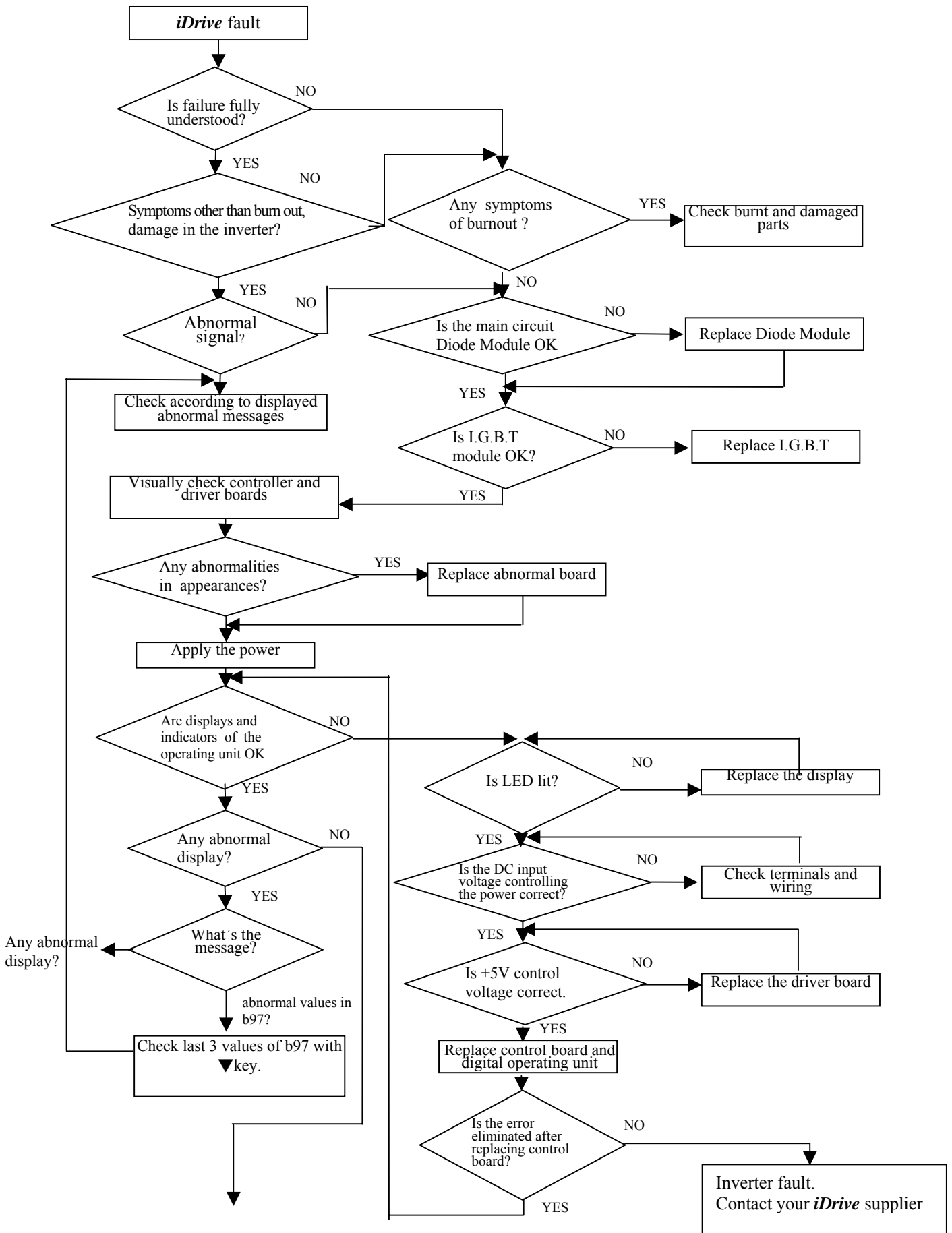

\* to next page

\* to previous page

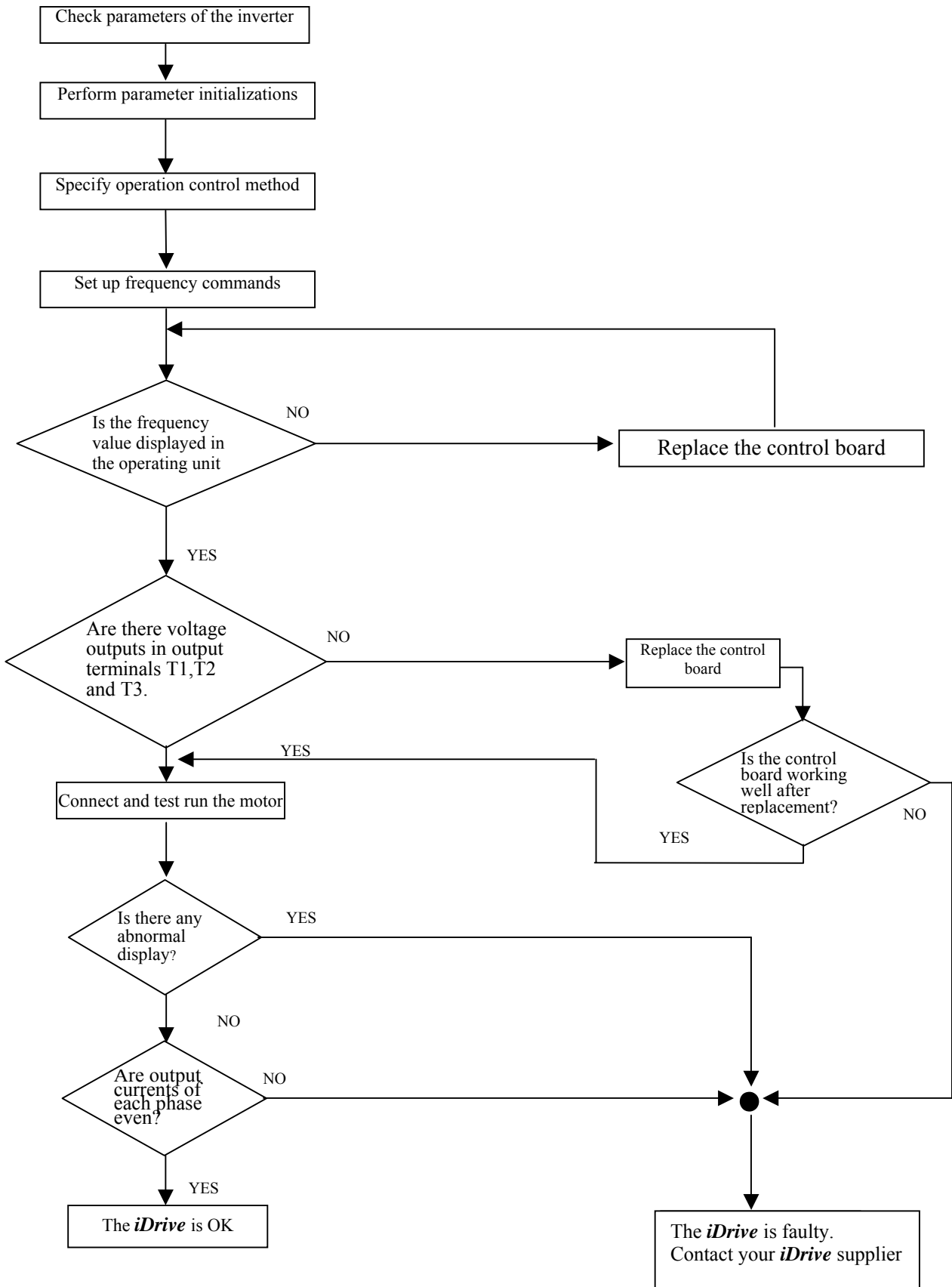

**Troubleshooting for OC, OL error displays**

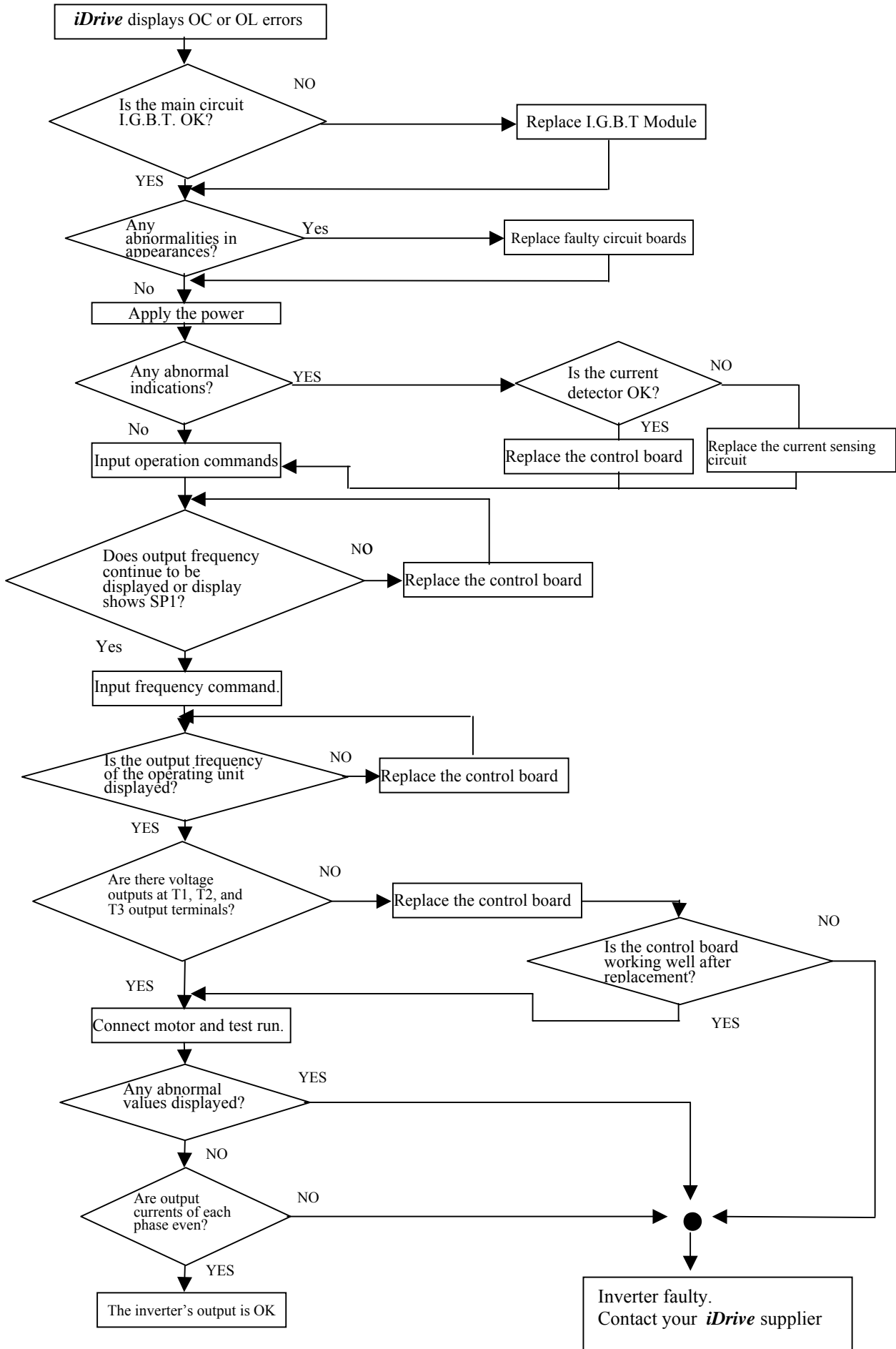



Troubleshooting for OV, LV error display

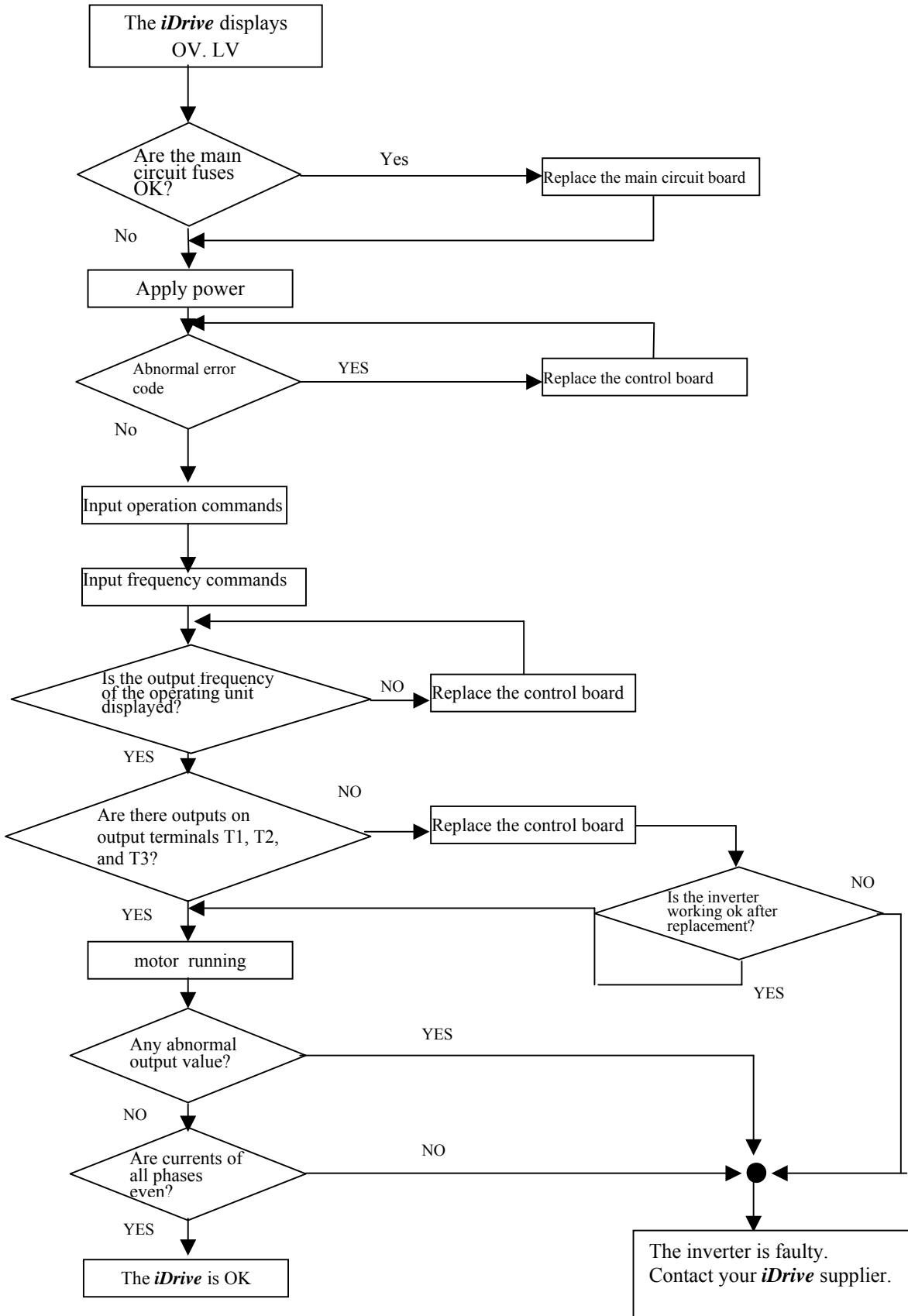

**The *iDrive* will not power-up / Motor will not run**

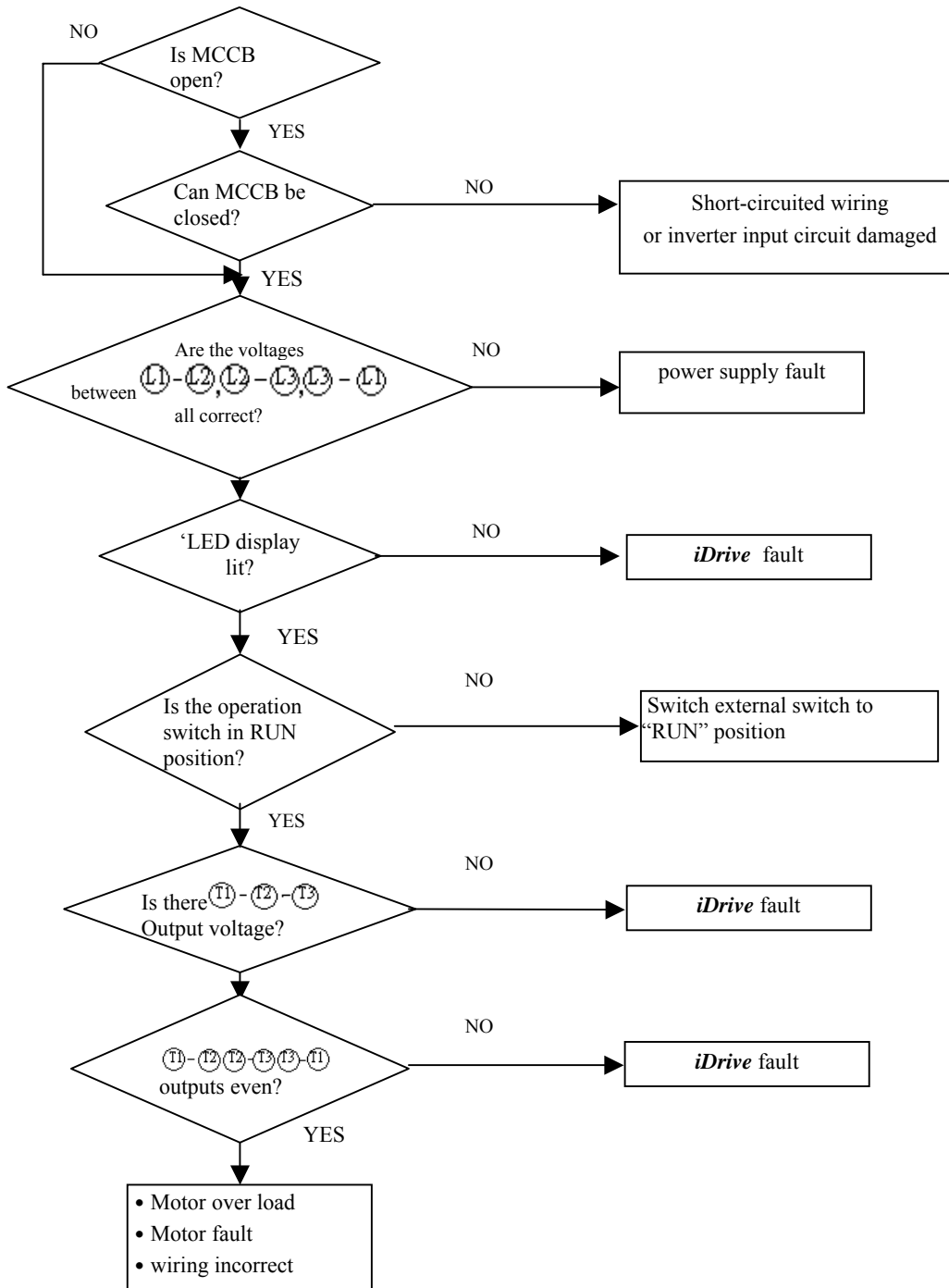

### Motor overheating

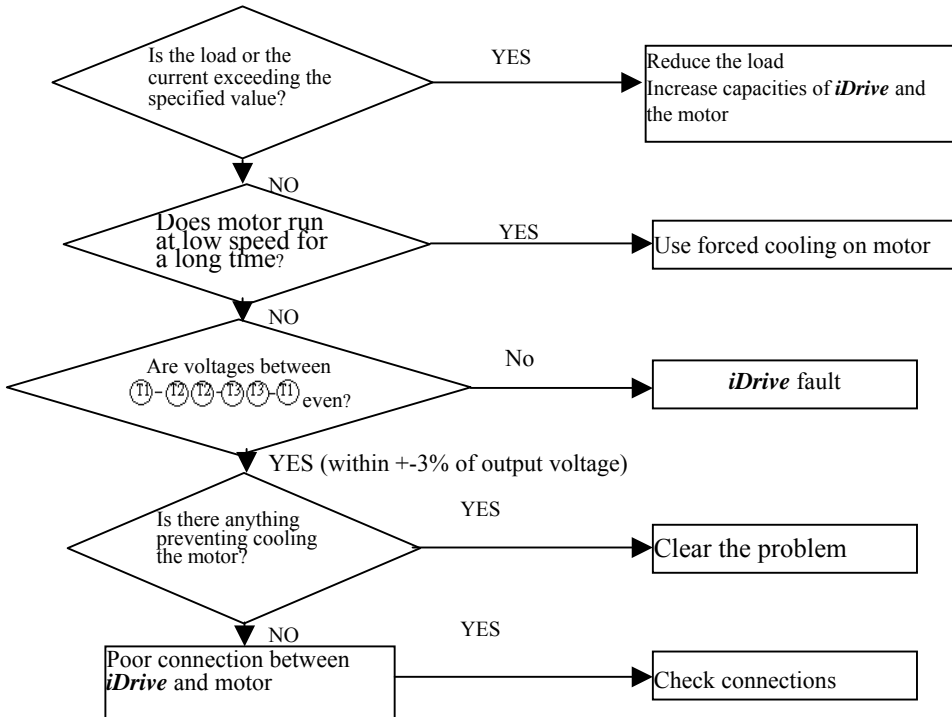

### Motor runs unevenly

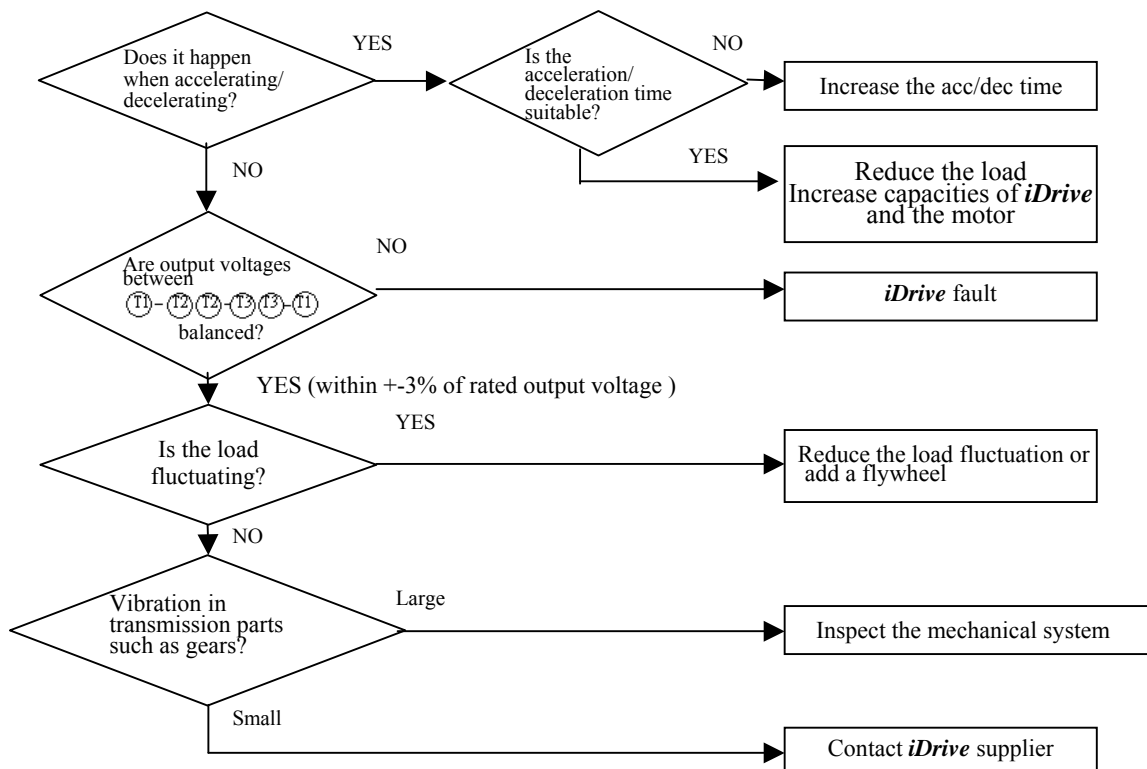

## 5.4 Routine periodic checks

To ensure stable and safe operation, check and maintain the inverter regularly.

The table below lists the items requiring checking to ensure safe operation.

Check these items 5 minutes after the “Charge” indicator goes out to prevent service persons from being hurt by residual electric power.

Items	Details	Checking period		Methods	Criteria	Remedies
		Week	Year			
Circumstances around the machine	Confirm the temperature and humidity around the machine	<input type="radio"/>		Measure with thermometer and hygrometer according to installation notices.	Temperature: -10 – 50°C Humidity: Below 95% RH	
	Are there inflammable materials in proximity?	<input type="radio"/>		Visual check	No foreign matters	
Installation and grounding of the inverter	Any unusual vibration from the machine	<input type="radio"/>		Visual, hearing	No foreign matters	Secure screws
	Is the grounding resistance / earth-loop impedance correct?		<input type="radio"/>	Measure the resistance	According to national regulations	Improve the grounding path
Input power voltage	Is the voltage of the main circuit correct?		<input type="radio"/>	Measure the voltage with a multi-meter	Voltage must conform with the specifications	Improve power supply
External terminals and internal mounting screws of the inverter	Are secure parts loose?		<input type="radio"/>	Visual check Check with a screwdriver (Make sure power is OFF first)	No abnormalities or cross-threading	Secure or send back for repair
	Is the terminal base damaged?		<input type="radio"/>			
	Obvious corrosion?		<input type="radio"/>			
Internal wiring of the inverter	Trapped or over-heated?		<input type="radio"/>	Visual check	No abnormalities	Inform your supplier
	Any damage of to the insulation?		<input type="radio"/>			
Heat sink	Build-up of dust deposits	<input type="radio"/>		Visual check	No abnormalities	Clean away dust
Printed circuit board	Build-up of conductive metal or oil sludge		<input type="radio"/>	Visual check	No abnormalities	Clean up or replace the circuit board
	Discolored, overheated, or burned parts		<input type="radio"/>			
Cooling fan	Check if operating ok or unusual vibration and noise	<input type="radio"/>		Visual or hearing check	Clean, quiet, operating OK	Replace the cooling fan
	Build-up of dust deposits	<input type="radio"/>		Visual check		Clean
Power component	Build-up of dust deposits		<input type="radio"/>	Visual check	No abnormalities	Clean up
	Check circuit between terminals		<input type="radio"/>	Measure with a multi-tester (diode checker)	No short circuit or damage to input/output circuits	Replace power component or inverter
DC Link Capacitor(s)	Any unusual odor or leakage of electrolyte		<input type="radio"/>	Visual check	No abnormalities	Replace capacitor or inverter
	Any splits / swelling to case or end caps?		<input type="radio"/>			
	High temperatures?		<input type="radio"/>			

## 5.5 Maintenance and inspection

The *iDrive* doesn't need daily inspection and maintenance.

To ensure long-term reliability, follow the instructions below when performing regular inspection.

**ALWAYS** turn the power off and wait for the keypad LED display to extinguish before inspection or maintenance begins to avoid potential shock hazard caused by high residual charge in the DC link capacitors.

If in doubt wait 10 minutes after switching off power supply, then test across terminals + and – with a multi-meter for the presence of DC voltage.

- (1) Clean up any accumulation of dust or foreign matter inside the inverter.
- (2) Check if there are any loose terminal screws and securing screws. Tighten all loose screws.
- (3) Insulation tests
  - (a) Disconnect all leads connecting *iDrive* with external circuits when performing insulation tests.
  - (b) Internal insulation test should be performed on the main circuit of the *iDrive* only. Use a high resistance 500VDC meter with insulating resistance higher than 5MΩ.

See diagram below: -

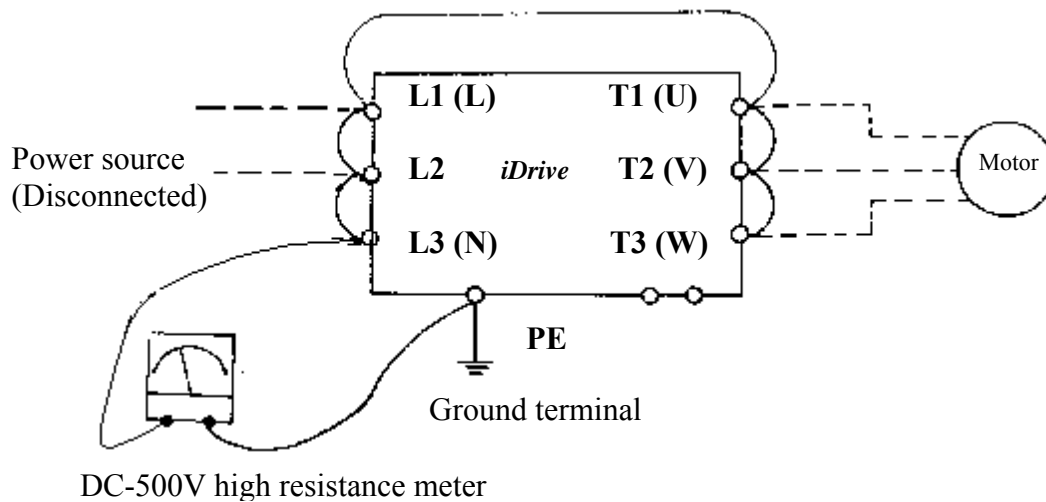

**Caution! Do not perform this test on the control circuit or damage will occur.**

# Chapter 6 Options

## 6.1 Option cards

### 6.1.1 RS-485 option card (EDX-485)

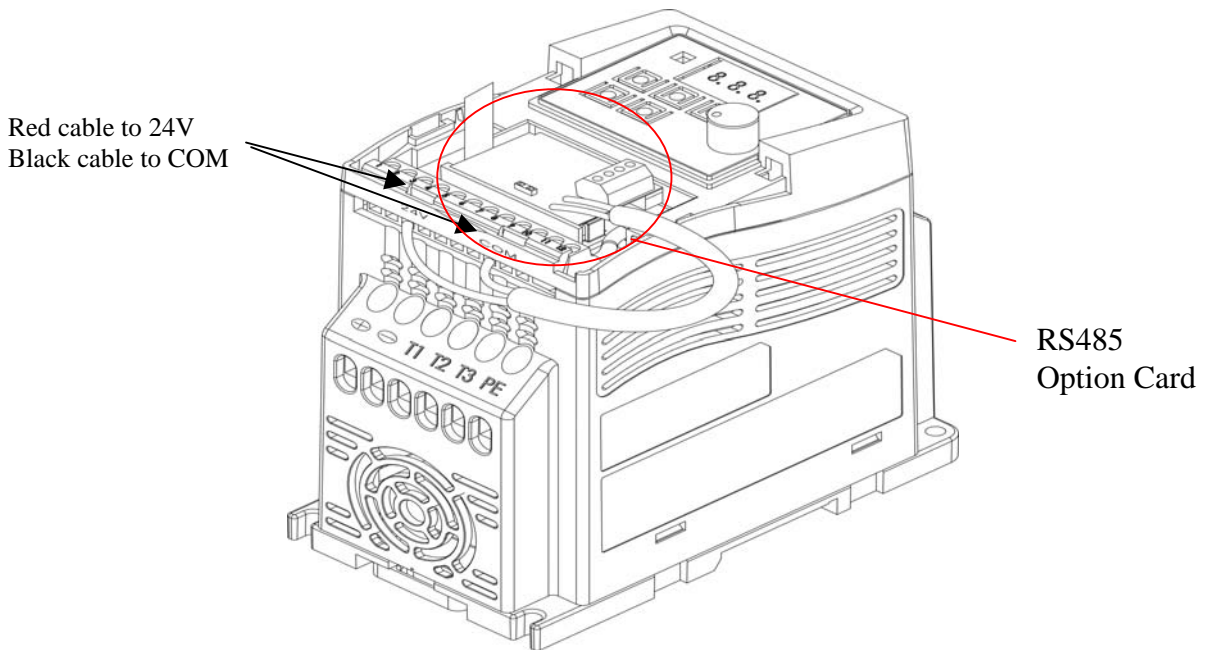

EDX-485 connection diagram:

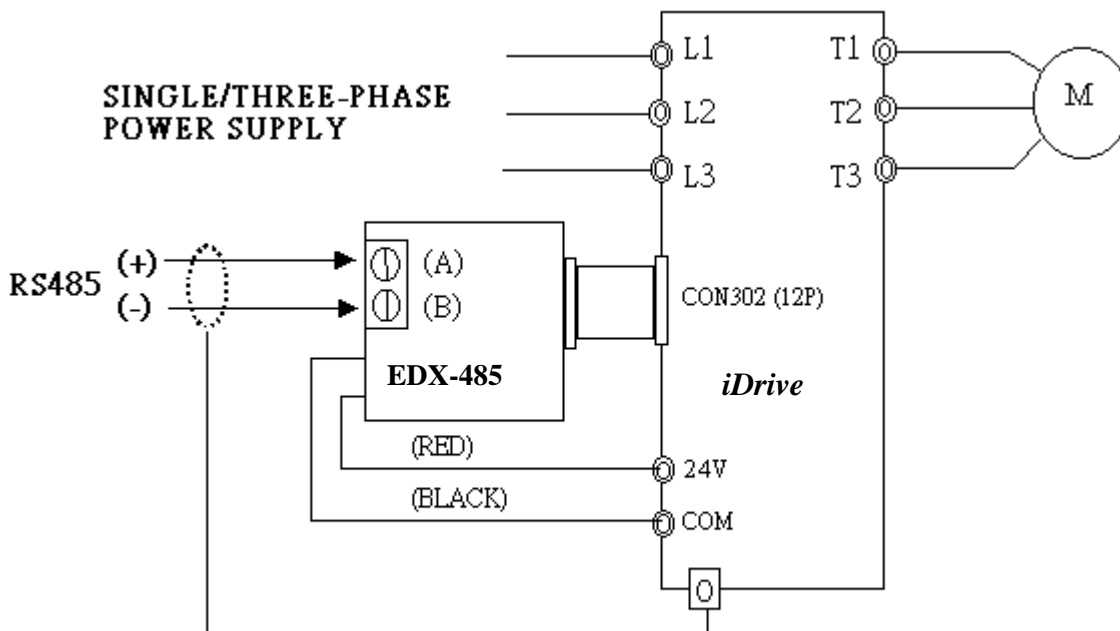

Note :

In order to avoid external interfere with option card, fit top cover to the main unit.  
 Use isolated RS232 / RS485 converter connecting with PC and option card to avoid damaging configuration.

6.1.2 RS-232 option card and cable (EDX-232)

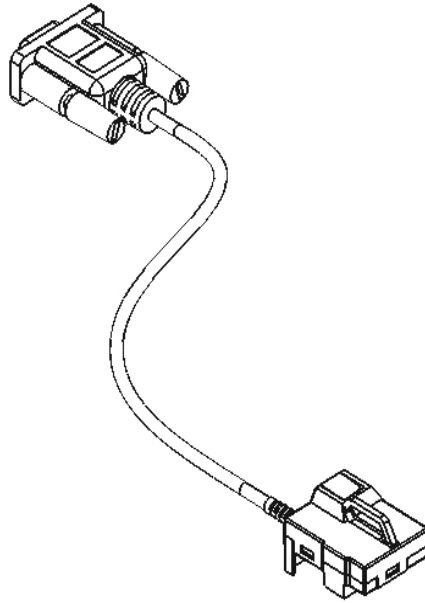

EDX-232 connection diagram

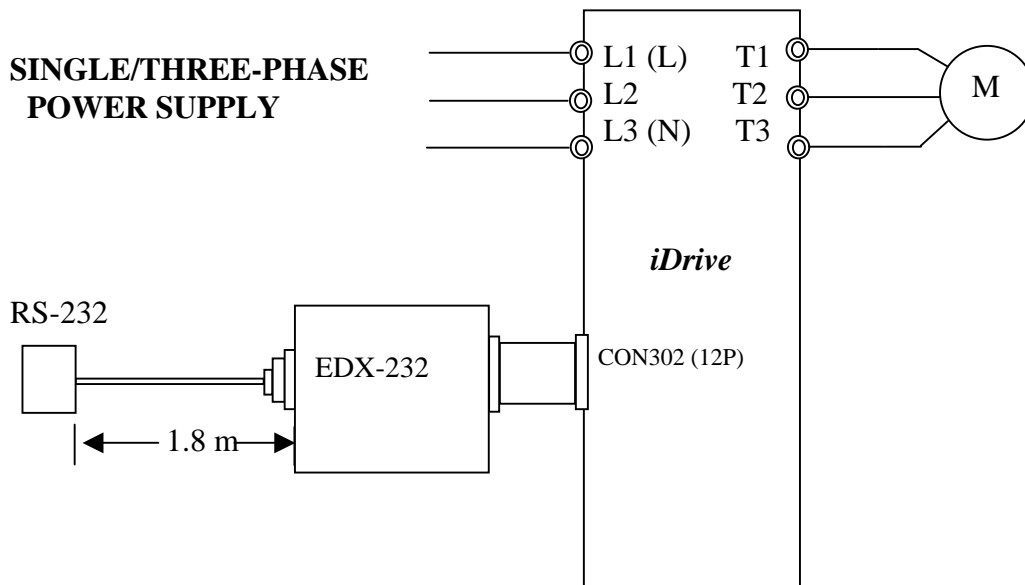

6.1.3 Program Copy option card (EDX-MP)

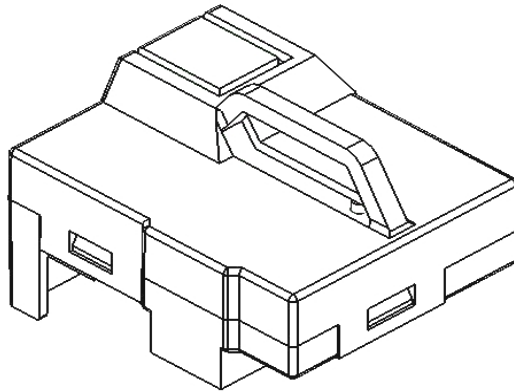

EDX-MP connection diagram

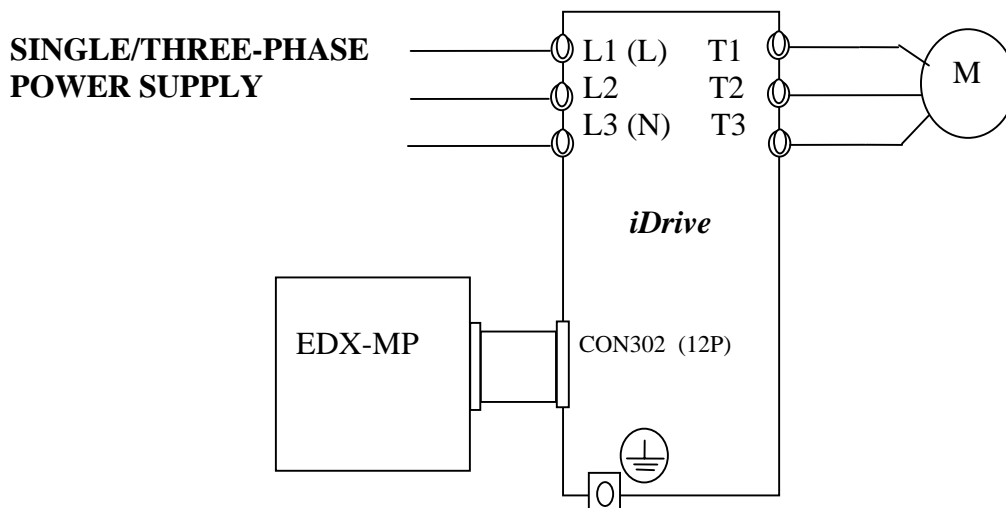



## 6.1.4 Remote keypad (EDX-LED)

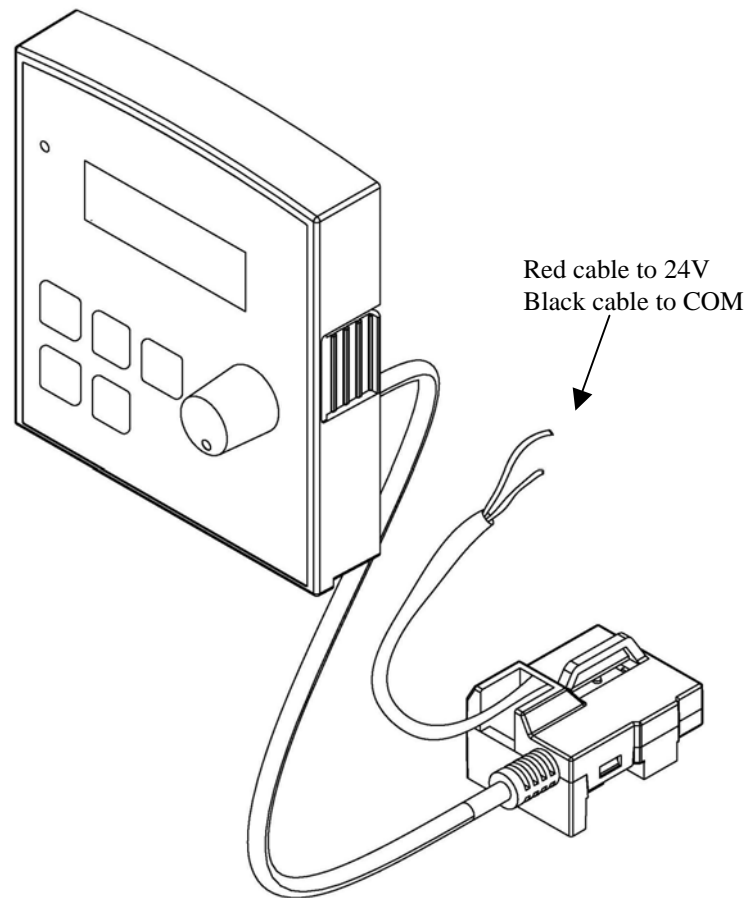

EDX-LED connection diagram

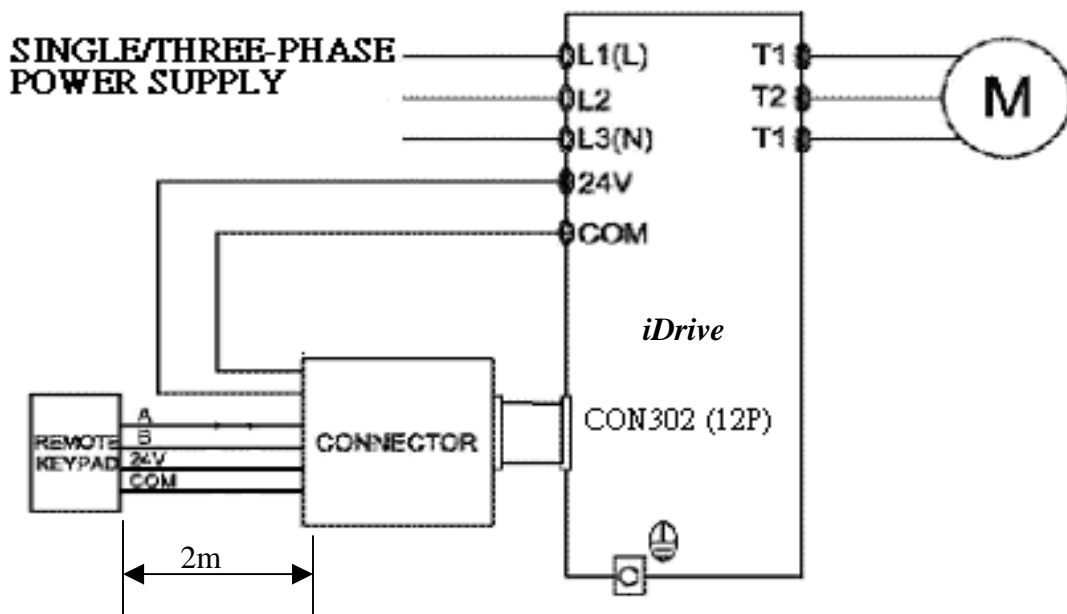

- When the inverter is powered on or off it is possible to set up or remove the remote keypad, but must be connected to TM2 24V DC power in normal use.
- For remote keypad operation set parameter b85 according to required action.

6.1.5 2 IN/1OUT expansion card (EDX-IO)

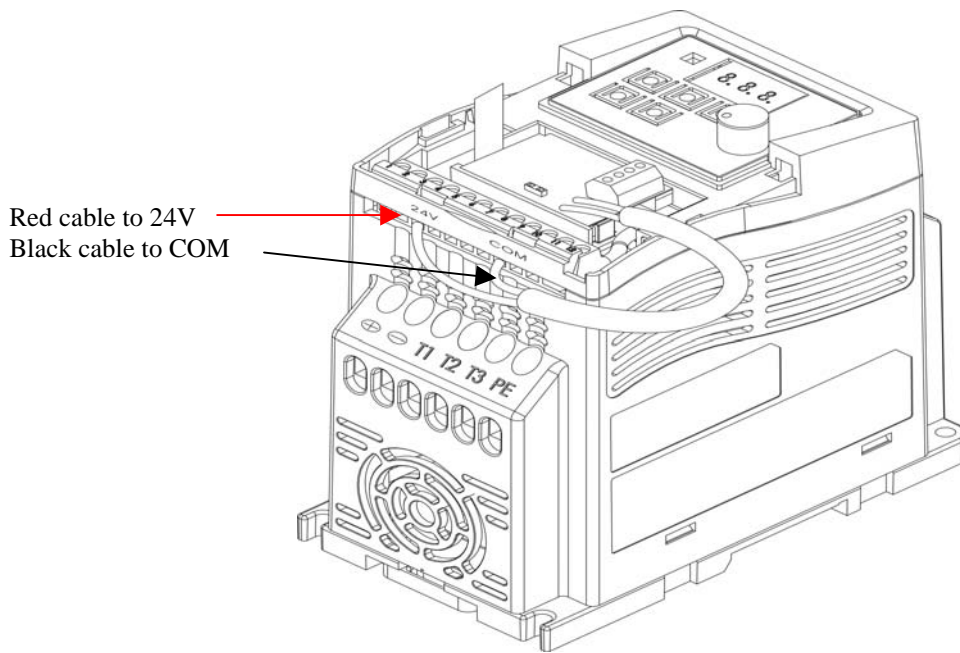

2 In/1 Out card wiring diagram

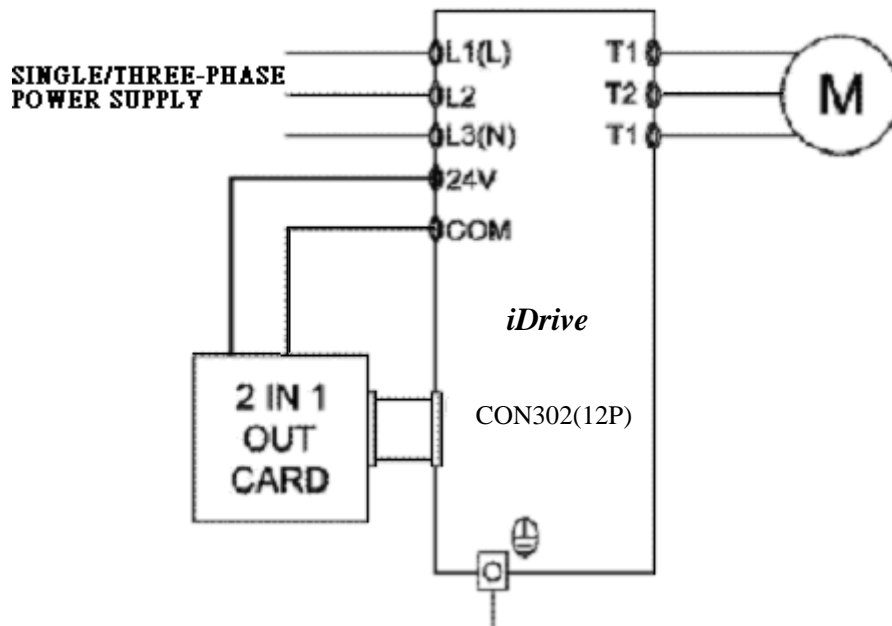

Appendix: *iDrive* -EDX inverter parameter setting list

Inverter model: EDX-			Company:		
Date:		Application:			
Engineer:		Note:			
Parameter Number	Setting	Parameter Number	Setting	Parameter Number	Setting
A00		b24		b62	
A01		b25		b63	
A02		b26		b64	
A03		b27		b65	
A04		b28		b66	
A05		b29		b67	
A06		b30		b68	
A07		b31		b69	
A08		b32		b70	
A09		b33		b71	
A10		b34		b72	
A11		b35		b73	
A12		b36		b74	
		b37		b75	
b00		b38		b76	
b01		b39		b77	
b02		b40		b78	
b03		b41		b79	
b04		b42		b80	
b05		b43		b81	
b06		b44		b82	
b07		b45		b83	
b08		b46		b84	
b09		b47		b85	
b10		b48		b86	
b11		b49		b87	
b12		b50		b88	
b13		b51		b89	
b14		b52		b90	
b15		b53		b91	
b16		b54		b92	
b17		b55		b93	
b18		b56		b94	
b19		b57		b95	
b20		b58		b96	
b21		b59		b97	
b22		b60			
b23		b61			