

FUSION IV REV B NVR
Digital Recording and Transmission System

User Manual

Revisions

Issue	Date	Revisions
A	July 2011	Based on 800-03703-A; updated for Rev B hardware and version 4.5 software
B	October 2011	Updated user notes

FCC Compliance Statement

INFORMATION TO THE USER: THIS EQUIPMENT HAS BEEN TESTED AND FOUND TO COMPLY WITH THE LIMITS FOR A CLASS B DIGITAL DEVICE, PURSUANT TO PART 15 OF THE FCC RULES. THESE LIMITS ARE DESIGNED TO PROVIDE REASONABLE PROTECTION AGAINST HARMFUL INTERFERENCE IN A RESIDENTIAL INSTALLATION. THIS EQUIPMENT GENERATES, USES AND CAN RADIATE RADIO FREQUENCY ENERGY AND, IF NOT INSTALLED AND USED IN ACCORDANCE WITH THE INSTRUCTIONS, MAY CAUSE HARMFUL INTERFERENCE TO RADIO COMMUNICATIONS. HOWEVER THERE IS NO GUARANTEE THAT INTERFERENCE WILL NOT OCCUR IN A PARTICULAR INSTALLATION. IF THIS EQUIPMENT DOES CAUSE HARMFUL INTERFERENCE TO RADIO OR TELEVISION RECEPTION, WHICH CAN BE DETERMINED BY TURNING THE EQUIPMENT OFF AND ON, THE USER IS ENCOURAGED TO TRY TO CORRECT THE INTERFERENCE BY ONE OR MORE OF THE FOLLOWING MEASURES:

- REORIENT OR RELOCATE THE RECEIVING ANTENNA.
- INCREASE THE SEPARATION BETWEEN THE EQUIPMENT AND RECEIVER.
- CONNECT THE EQUIPMENT TO AN OUTLET ON A CIRCUIT DIFFERENT FROM THAT TO WHICH THE RECEIVER IS CONNECTED.
- CONSULT THE DEALER OR AN EXPERIENCED RADIO/TV TECHNICIAN FOR HELP.

CAUTION: CHANGES OR MODIFICATIONS NOT EXPRESSLY APPROVED BY THE PARTY RESPONSIBLE FOR COMPLIANCE COULD VOID THE USER'S AUTHORITY TO OPERATE THE EQUIPMENT.

THIS CLASS B DIGITAL APPARATUS COMPLIES WITH CANADIAN ICES-003.

CET APPAREIL NUMÉRIQUE DE LA CLASSE B EST CONFORME À LA NORME NMB-003 DU CANADA.

OPERATION OF THIS DEVICE IS SUBJECT TO THE FOLLOWING CONDITIONS:

- THIS DEVICE MAY NOT CAUSE HARMFUL INTERFERENCE.
- THIS DEVICE MUST ACCEPT INTERFERENCE RECEIVED, INCLUDING INTERFERENCE THAT MAY CAUSE UNDESIRABLE OPERATION.
- CABLES USED WITH THIS DEVICE MUST BE PROPERLY SHIELDED TO COMPLY WITH THE REQUIREMENTS OF THE FCC.
- ANY CHANGES OR MODIFICATIONS NOT EXPRESSLY APPROVED IN THIS MANUAL COULD VOID YOUR AUTHORITY TO OPERATE THIS EQUIPMENT.

USERS OF THE PRODUCT ARE RESPONSIBLE FOR CHECKING AND COMPLYING WITH ALL FEDERAL, STATE, AND LOCAL LAWS AND STATUTES CONCERNING THE MONITORING AND RECORDING OF VIDEO AND AUDIO SIGNALS. HONEYWELL VIDEO SYSTEMS SHALL NOT BE HELD RESPONSIBLE FOR THE USE OF THIS PRODUCT IN VIOLATION OF CURRENT LAWS AND STATUTES.

National Power Deviation Standards

AUSTRALIA / NEW ZEALAND

COMPONENTS COMPLY WITH THE RELEVANT PORTIONS OF IEC 60950 OR THE APPLICABLE COMPONENT STANDARD OR THE RELEVANT AUSTRALIAN / NEW ZEALAND STANDARD.

AC POWER DISTRIBUTION SYSTEMS CLASSIFIED AS TT OR IT ARE NOT ALLOWED. THIS UNIT IS INTENDED FOR USE ON A TN SYSTEM.

DENMARK

CERTAIN TYPES OF CLASS I APPLIANCES MAY BE PROVIDED WITH PLUG NOT ESTABLISHING EARTHING CONTINUITY WHEN INSERTED INTO DANISH SOCKET-OUTLETS.

"VIGTIGT !

LEDEREN MED GRØN/GUL ISOLATION MÅ KUN

TILSLUTTES EN KLEMME MÆRKET

(IEC 417, NO. 5019) ELLER (IEC 417, NO. 5017)

FOR TILSLUTNING AF DE ØVRIGE LEDERE, SE MEDFØLGENDE INSTALLATIONSVEJLEDNING

SUPPLY CORD OF SINGLE-PHASE EQUIPMENT HAVING A RATED CURRENT NOT EXCEEDING 13 A SHALL BE PROVIDED WITH A PLUG ACCORDING TO THE HEAVY CURRENT REGULATIONS, SECTION 107-2-D1. CLASS I EQUIPMENT PROVIDED WITH SOCKET-OUTLETS WITH EARTH CONTACT OR WHICH ARE INTENDED TO BE USED IN LOCATIONS WHERE PROTECTION AGAINST INDIRECT CONTACT IS REQUIRED ACCORDING TO THE WIRING RULES SHALL BE PROVIDED WITH A PLUG IN ACCORDANCE WITH STANDARD SHEET DK 2-1A OR DK 2-5A. IF POLY-PHASE EQUIPMENT AND SINGLE-PHASE EQUIPMENT HAVING A RATED CURRENT EXCEEDING 13 A IS PROVIDED WITH A SUPPLY CORD WITH A PLUG, THIS PLUG SHALL BE IN ACCORDANCE WITH THE HEAVY CURRENT.

GERMANY

(GESETZ UBER TECHNISCHE ARBEITSMITTEL (GARATESICHERHEITSGESETZ) [LAW OF TECHNICAL LABOUR EQUIPMENT {EQUIPMENT SAFETY LAW}], OF 23RD OCTOBER 1992, ARTICLE 3, 3RD PARAGRAPH, 2ND SENTENCE, TOGETHER WITH THE "ALLGEMEINE VERWALTUNGSVORSCHRIFT ZUR URCHFUHRUNG DES ZWEITEN ABSCHRITTS DES GERATESICHERHEITSGESETZES" [GENERAL ADMINISTRATIVE REGULATION ON THE EXECUTION OF THE SECOND SECTION OF THE EQUIPMENT SAFETY LAW], OF 10TH JANUARY 1996, ARTICLE 2, THE PARAGRAPH, ITEM 2).

KOREA

PLUGS FOR THE CONNECTION OF THE APPARATUS TO THE SUPPLY MAINS COMPLY WITH THE KOREAN REQUIREMENT (KSC 8305).

EMC - THE APPARATUS SHALL COMPLIES WITH THE RELEVANT CISPR STANDARDS.

SWITZERLAND

SUPPLY CORDS OF EQUIPMENT HAVING A RATED CURRENT NOT EXCEEDING 10 A SHALL BE PROVIDED WITH A PLUG

COMPLYING WITH SEV 1011 OR IEC 60884-1 AND ONE OF THE FOLLOWING DIMENSION SHEETS:

SEV 6532-2.1991, PLUG TYPE 15, 3P+N+PE 250/400 V,10 A

SEV 6533-2.1991, PLUG TYPE 11, L+N 250 V,10 A

SEV 6534-2.1991, PLUG TYPE 12, L+N+PE 250 V,10 A

IN GENERAL, EN 60309 APPLIES FOR PLUGS FOR CURRENTS EXCEEDING 10 A. HOWEVER, A 16 A PLUG AND SOCKETOUTLET SYSTEM IS BEING INTRODUCED IN SWITZERLAND, THE PLUGS OF WHICH ARE ACCORDING TO THE FOLLOWING DIMENSION SHEETS, PUBLISHED IN FEBRUARY 1998:

SEV 5932-2.1998, PLUG TYPE 25, 3P+N+PE 230/400 V,16 A

SEV 5933-2.1998, PLUG TYPE 21, L+N 250 V,16 A

SEV 5934-2.1998, PLUG TYPE 23, L+N+PE 250 V,16 A

UNITED KINGDOM

THE CURRENT RATING OF THE CIRCUIT SHALL BE TAKEN AS 13 A, NOT 16 A.

RATING OF CIRCUIT UNDER TEST WAS TAKEN TO BE 20 A.

APPARATUS WHICH IS FITTED WITH A FLEXIBLE CABLE OR CORD AND IS DESIGNED TO BE CONNECTED TO A MAINS SOCKET CONFORMING TO BS 1363 BY MEANS OF THAT FLEXIBLE CABLE OR CORD AND PLUG, SHALL BE FITTED WITH A "STANDARD PLUG" IN ACCORDANCE WITH STATUTORY INSTRUMENT 1786: 1994 - THE PLUGS AND SOCKETS ETC. (SAFETY) REGULATIONS 1994, UNLESS EXEMPTED BY THOSE REGULATIONS. NOTE: "STANDARD PLUG" IS DEFINED IN SI 1786: 1994 AND ESSENTIALLY MEANS AN APPROVED PLUG CONFORMING TO BS 1363 OR AN APPROVED CONVERSION PLUG.

Rack Mount Instructions

- A) Elevated Operating Ambient – If installed in a closed or multi-unit rack assembly, the operating ambient temperature of the rack environment may be greater than room ambient. Therefore, consideration should be given to installing the equipment in an environment compatible with the maximum ambient temperature (T_{ma}) specified by the manufacturer.
 - B) Reduced Air Flow – Installation of the equipment in a rack should be such that the amount of air flow required for safe operation of the equipment is not compromised.
 - C) Mechanical Loading – Mounting of the equipment in the rack should be such that a hazardous condition is not achieved due to uneven mechanical loading.
 - D) Circuit Overloading – Consideration should be given to the connection of the equipment to the supply circuit and the effect that overloading of the circuits might have on over current protection and supply wiring. Appropriate consideration of equipment nameplate ratings should be used when addressing this concern.
 - E) Reliable Earthing – Reliable earthing of rack-mounted equipment should be maintained. Particular attention should be given to supply connections other than direct connections to the branch circuit (e.g. use of power strips).
-

UL Notice

Underwriters Laboratories Inc. has not tested the performance or reliability of the security or signaling aspects of this product. UL has only tested for fire, shock and casualty hazards as outlined in UL's Standard for Safety UL 60950-1. UL Certification does not cover the performance or reliability of the security or signaling aspects if this product.

UL MAKES NO REPRESENTATIONS, WARRANTIES OR CERTIFICATIONS WHATSOEVER REGARDING THE PERFORMANCE OR RELIABILITY OF ANY SECURITY OR SIGNALING RELATED FUNCTIONS OF THIS PRODUCT.

CE Notice

This product is in conformity with the following European Directives:

ELECTROMAGNETIC COMPATIBILITY DIRECTIVE, 2004/108/EC

per the provisions of:

EN 55022:2006 + A1:2007 (Class B)

EN 61000-3-2:2006 + A2:2009

EN 61000-3-3:2008

EN50130-4:1995 + A1:1998 + A2:2003

LOW VOLTAGE DIRECTIVE, 2006/95/EC

per the provisions of:

EN60950-1:2006 A11:2009

EN50130-4:1995 + A1:1998 + A2:2003

1. Uninterrupted Power supply (UPS) required.
2. Maximum lengths of wiring connected to the sensor inputs and control outputs are 30 meters.

Optical and Acoustical Statements

VISIBLE LED STATEMENT

The LEDs on this DVR unit are classified as “Class 1 LED Product” in accordance with EN 60825-1.

LASER SAFETY STATEMENT FOR A CLASS 1 LASER PRODUCT

This DVD-ROM Storage device fulfills the required Laser measurements and classification for Class 1 Laser Products according to the requirements in US Food and Drug Administration, CDRH Title 21 CFR Sec. 1040.10, 2008.

The mass storage system does not product hazardous laser radiation. Because laser light emitted inside the mass storage system is completely confined within the protective housings and external covers, the laser beam cannot escape from the machine during any phase of user operation.



CAUTION: Due to the extremely fast rotation speed of the DVD-ROM drive spindle motor (9000 ~ 12000 rpm), the drive's performance could be affected by using substandard discs. These substandard discs may be damaged, or damage the DVD-ROM drive.

Check each DVD for cracks before using it. If there are cracks on the surface, especially on the border of the center hole, do not use it in the DVD-ROM drive. Using such DVDs can cause irreparable damage to the DVD-ROM drive.

Do not leave DVDs in direct sunlight or hot, humid locations.

Always remove DVDs from the drive after use.

To protect DVDs from scratches, never touch the DVD face or place the DVD face down on a hard surface.

Do not affix highly adhesive stickers to a DVD.

ACOUSTIC NOISE STATEMENT

Lpa < 70 dB operator position, normal operation, per ISO 7779.

Important Safeguards

1. **Read Owner's Manual** – After unpacking this product, read the owner's manual carefully, and follow all the operating and other instruction
2. **Power Sources** – This product should be operated only from the type of power source indicated on the label. If you are not sure of the type of power supply to your home or business, consult your product dealer or local power company
3. **Ventilation** – Slots and openings in the cabinet are provided for ventilation and to ensure reliable operation of the product and to protect it from overheating, and these openings must not be blocked or covered. The product should not be placed in a built-in installation such as a bookcase or rack unless proper ventilation is provided or the manufacturer's instructions have been adhered to.
4. **Heat** – The product should be situated away from heat sources such as radiators, heat registers, stoves, or other products that produce heat.
5. **Water and Moisture** – Do not use this product near water. Do not exceed the humidity specifications for the product as detailed in this manual.
6. **Cleaning** – Unplug this product from the wall outlet before cleaning. Do not use liquid cleaners or aerosol cleaners. Use a damp cloth for cleaning.
7. **Power Cord Protection** – Power-supply cords should not be routed so that they are not likely to be walked on or pinched by items placed against them, paying particular attention to cords at plugs, convenience receptacles, and the point where they exit from the product.
8. **Overloading** – Do not overload wall outlets; extension cords, or integral convenience receptacles as this can result in a risk of fire or electrical shock.
9. **Lightning** – For added protection for this product during storm, or when it is left unattended and unused for long periods of time, unplug it from the wall outlet. This will prevent damage to the product due to lightning and power line surges.
10. **Object and Liquid Entry Points** – Never insert foreign objects into the NVR, other than the media types approved by Honeywell, as they may touch dangerous voltage points or short-out parts that could result in a fire or electrical shock. Never spill liquid of any kind on the product.
11. **Accessories** – Do not place this product on an unstable cart, stand, tripod, bracket, or table. The product may fall, causing serious personal injury and serious damage to the product.
12. **Disc Tray** – Keep fingers clear of the disc tray as it is closing. Neglecting to do so may cause serious personal injury.
13. **Burden** – Do not place a heavy object on or step on the product. The object may fall, causing serious personal injury and serious damage to the product.
14. **Disc** – Do not use a cracked, deformed, or repaired disc. These discs are easily broken and may cause serious personal injury and product malfunction.

15. **Damage Requiring Service** – Unplug the unit from the outlet and refer servicing to qualified service personnel under the following conditions:
When the power-supply cord or plug is damaged.
If liquid has been spilled, or objects have fallen into the unit.
If the unit has been exposed to rain or water.
If the unit does not operate normally by following the operating instructions. Adjust only those controls that are covered by the operating instructions as an improper adjustment of other controls may result in damage and will often require extensive work by a qualified technician to restore the unit to its normal operation.
If the unit has been dropped or the enclosure has been damaged.
When the unit exhibits a distinct change in performance - this indicates a need for service.
16. **Servicing** – Do not attempt to service this product yourself as opening or removing covers may expose you to dangerous voltage or other hazards. Refer all servicing to qualified personnel.
17. **Replacement Parts** – When replacement parts are required, be sure the service technician has used replacement parts specified by the manufacturer or have the same characteristics as the original part. Unauthorized substitutions may result in fire, electric shock or other hazards.
18. **Safety Check** – Upon completion of any service or repairs to this unit, ask the service technician to perform safety checks to determine that the unit is in proper operating condition.

Notes on Handling

- When shipping the NVR, the original shipping carton packing materials come in handy. For maximum protection, repack the unit as it was originally packed at the factory.
- Do not use volatile liquids, such as aerosol spray, near the NVR. Do not leave rubber or plastic products in contact with the NVR for long periods of time. They will leave marks on the finish.
- The top and rear panels of the NVR may become warm after long periods of use. This is not a malfunction.

Notes on Locating

- Place the NVR on a level surface. Do not use it on a shaky or unstable surface such as a wobbling table or inclined stand.
- When you place this NVR next to a TV, radio, or VCR, the playback picture may become poor and the sound may be distorted. If this happens, place the NVR away from the TV, radio, or VCR.

Notes on Cleaning

- Use a soft dry cloth for cleaning.
- For stubborn dirt, soak the cloth in a weak detergent solution, wring well and wipe. Use a dry cloth to wipe it dry. Do not use any type of solvent, such as thinner and benzene, as they may damage the surface of the NVR.
- If using a chemical saturated cloth to clean the unit, follow that product's instructions.

Notes on Maintenance

This NVR is designed to last for long periods of time. To keep your NVR always operational we recommend regular inspection maintenance (cleaning parts or replacement). For details contact your nearest dealer.

Notes on Moisture Condensation

Moisture condensation damages the NVR. Read the following information carefully.

Moisture condensation occurs during the following cases:

- When you bring the NVR directly from a cold place to a warm place.
- When you use the NVR in a room where you just turned on the heater, or a place where the cold wind from the air conditioner directly hits the unit.
- In the summer, when you use the NVR in a hot and humid place just after you move the unit from an air conditioned room.
- When you use the NVR in a humid place.

Do not use the NVR when moisture condensation may occur.

If you use the NVR in such a situation, it may damage discs and internal parts. Remove any DVD discs, connect the power cord of the NVR to the wall outlet, turn on the NVR, and leave it for two to three hours. After two to three hours, the NVR will have warmed up and evaporated any moisture. Keep the NVR connected to the wall and moisture will seldom occur.

WARNING

TO REDUCE THE RISK OF ELECTRICAL SHOCK, DO NOT EXPOSE THIS APPLIANCE TO RAIN OR MOISTURE.
DANGEROUS HIGH VOLTAGES ARE PRESENT INSIDE THE ENCLOSURE.
DO NOT OPEN THE CABINET.
REFER SERVICING TO QUALIFIED PERSONNEL ONLY.

CAUTION

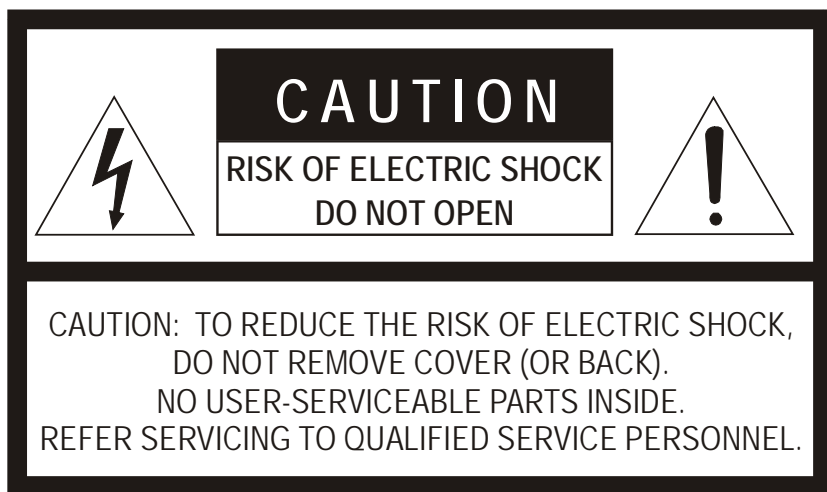

Contents

1	Contents	12
2	Introduction	17
	Product Description.....	17
	Features.....	18
3	Controls and Connections	19
	Front Panel Controls and LEDs.....	19
	Rear Panel Connectors	20
4	Getting Started	21
	Identifying Included Components.....	21
	Keyboard Setup	22
	Mouse Setup.....	22
	Monitor Setup.....	23
	Power Setup	23
	Optional Components	24
	Turning On the Recorder	24
	Turning Off the Recorder	24
5	DVR Basics	25
	Setting the Time and Date	25
	Accessing the DVR Utility.....	26
	Exporting DVR Settings	26
	Importing DVR Settings	26
	Changing Video Format.....	27
	Live View screen.....	27
	Live Camera Options	28
	Camera View	29
	Recording Status Indicator	29
	Special Recording.....	29
	Screen Division Buttons	30
	Dual Monitor Camera Display Menu.....	30
	Custom Live View Divisions	31
6	Setup Options	32
	Setup Overview	32
	Setup Screen	33
	Camera Setup	34

Set Up New Camera	34
Network Video	35
Connecting a Network Device	35
Connecting Manually	35
Connecting with Camera Finder	36
Assigning a Network Device to a Channel	36
Assigning Audio Channels to a Network Device	37
Camera Configuration	38
Enable/Disable Live Video	38
Displaying More Columns	38
Accessing the Configuration Menu	39
Motion Setup	39
Regular Interval Recording	39
Enable Sabotage Detection	40
Create a Motion Area	40
General Setup	41
Voice Warning	42
Video Loss Alarm	42
Volume	43
Connecting to a Wide Screen Display	43
Connecting a Second Monitor	43
Auto Sequence Setting	44
Create Custom Auto Sequence	44
Hybrid Sensor Setup	45
Schedule Setup	46
Default Schedules	47
Day of the Week	47
Creating a Simple Schedule (By Example)	47
Scheduling Sensors and Relays (By Example)	51
Verifying a Recording Schedule	52
Network Setup	53
Administration	54
Disk Management	55
Setting up DDNS	56
Enable DDNS	56
Set the IP Address	56
User Management	57
Add a New User	57
User Rank	58
Changing the Administrator Password	58
Default Administrator Password	58
Log Management	58
Set up Log Management Options	59
Status Check / Email	60
General	60
Users	60
Storage Check	61

	Recording Data Check	61
	SMART Information.....	61
	SMART Alert.....	62
	Alarm Event.....	62
	Data Management.....	62
	Information	63
	Instant Recording	64
	Activate Instant Recording.....	64
	Searching 'Instant Recorded' Video	64
7	Search	65
	Search Overview	65
	Play Controls.....	66
	Hour / Minute Controls.....	66
	Brightness / Speed / Zoom.....	66
	Adjusting the Brightness of an Image	66
	Zooming in on an Image.....	67
	Zooming in on a Portion of an Image.....	67
	Adjust the Brightness of an Image	67
	Zooming in on an Image.....	67
	Zooming in on a Portion of an Image.....	67
	Open Video from a Saved Location	67
	Time Sync	68
	After Image Removal.....	68
	Performing a Basic Search	68
	Printing an Image	68
	Daylight Saving Time	69
	Save to JPG or AVI.....	69
	Bookmarks	71
	Modify Bookmarks.....	71
	Single Clip Backup	72
	Single Clip Backup Using Bookmark Data	72
	Index Search	73
	Performing an Index Search	73
	Index Search Results Display	73
	Preview Search.....	74
	Performing a Preview Search	75
	Object Search.....	75
	Performing an Object Search	76
	Status Search	77
	Performing a Status Search.....	77
	Motion Search	78
	Performing a Motion Search.....	78
	Audio Playback	79
8	Pan / Tilt / Zoom.....	80
	Pan / Tilt / Zoom Overview	80
	Enable the PTZ Settings	80
	Advanced PTZ Setup	81

Creating and Viewing Preset Positions	81
Creating a Preset	81
Viewing a Preset	82
Understanding Tours	82
Creating a Preset Tour.....	83
Viewing the Preset Tour.....	83
Creating a Preset Tour2.....	83
Viewing the Preset Tour2.....	83
Creating a Mimic Tour	83
Viewing the Mimic Tour	83
PTZ Status on Close	84
Activating the PTZ Status on Close Option.....	84
PTZ Tour Scheduling	84
Create PTZ Tour Schedule	84
PTZ Address Setting	85
Accessing PTZ Menus	85
Opening and Editing the Honeywell MAXPRO Menu	85
Controlling a PTZ Camera.....	86
Using the On-Screen Compass.....	86
Using the PTZ Controller	87
AUX Buttons.....	87
9 Backing up Video Data	88
Backup Overview	88
Nero® Express.....	88
General Screen Overview	89
Performing a General Backup	89
Clip Screen Overview.....	90
Performing a Clip Backup	90
Scheduled Screen Overview	91
Performing a Scheduled Backup	91
Specifying Scheduled Backup Drives.....	91
10 LAN / ISDN / PSTN Connections.....	92
LAN Overview	92
Connecting to a LAN Using TCP/IP	93
Configuring TCP/IP Settings.....	93
11 LDAP Integration.....	94
Features.....	94
Installing LDAP	95
12 Web Viewer	97
Web Viewer Overview.....	97
Configuring the Server for Remote Connection.....	98
Connecting to a DVR Using Web Viewer	98
Closing the Web Viewer.....	98
13 Included Software Setup	99
Proprietary Viewer Overview	99
Installing the Proprietary Viewer	100
Loading Video from DVD-ROM or Hard Drive	100

Contents

Digital Verifier Overview	101
Installing the Digital Verifier	101
Using the Digital Verifier.....	101
Alarm Monitor Overview	102
Installing the Alarm Monitor	102
Configuring the DVR	102
Configuring the Client PC	103
Alarm Monitor Window.....	104
Filter Event List.....	104
Search Alarm Window	105
View Recorded Video	105
Export Video	105
Fusion Remote Software Overview.....	106
Remote Client Minimum Requirements.....	107
Remote Client Recommended Requirements.....	107
Installing the Fusion Remote Software.....	107
Setting up the Server to Accept Incoming Communications.....	108
Setting up the Fusion Remote Software.....	109
Creating a New Remote Connection.....	109
FVMS Overview	110
FVMS System Requirements.....	110
Configuring the Server for Remote Connection	111
Connecting to a DVR	111
Health Check.....	112
Enable Health Check on the Fusion DVR	112

Introduction

Product Description

The Honeywell Fusion NVR is a server that performs as a High Definition Digital Recorder. By utilizing the many features of a computer, including processing power, storage capacity, graphics compression, and security features, the NVR is more powerful than the analog recorders of the past.

The Fusion series Network recorders are designed to capture video streams from network cameras and video servers and then record to hard drives for storage purposes.

The Honeywell Fusion NVR server software comes pre-configured for fast and seamless integration within the existing IT infrastructure. Designed around Microsoft® Windows 7, the server software offers unparalleled stability, security, and ease of use. Accordingly, a security investment has never been easier to maintain. Multiple users may simultaneously connect through any network connection for instantaneous live viewing, digital search, and off site video storage. Users can also connect remotely through DSL, Cable Modems, and ISDN. This powerful software enables users to establish recording schedules, create motion detection zones, and use PTZ controls. With the latest advancements in the NVR Server Software, searching and indexing the video archive has never been easier. Video can be found, viewed, and exported in a number of file formats with just a few clicks.

The Honeywell Fusion NVR is a high performance security product ready to meet today's security demands.

Features

Honeywell's Fusion NVRs include the following features:

- Optimized and designed for Microsoft® Windows 7 Embedded®
- Available 8, 16, and 32 channel configurations.
- Support for most industry leading network camera manufacturers.
- Remote system operation & configuration
- Supports multiple simultaneous remote connections
- Pan / Tilt / Zoom controls
- Simultaneous video search, playback, and backup
- Video indexes for easy searching
- Multiple levels of security access
- 1 channel of audio per camera (only on IP cameras that support audio)
- Supports resolutions up to 5 megapixel
- High performance, durable, rack mount case
- NTSC and PAL supported
- Virtually unlimited storage potential
- Supports digital signatures authentication
- Continuous motion detection, alarm, pre-alarm, and scheduled recording modes
- Software watchdog
- Camera dependant recording resolution

Controls and Connections

Front Panel Controls and LEDs

The front panel of the NVR contains the devices that will be commonly used for data removal, retrieval, and backup replacement. The most common components and buttons are shown below.

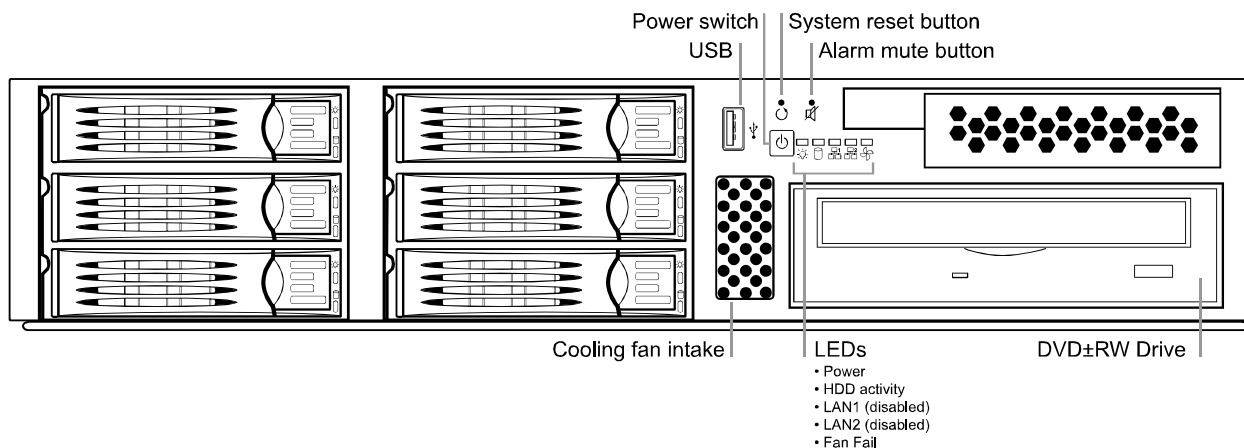

Rear Panel Connectors



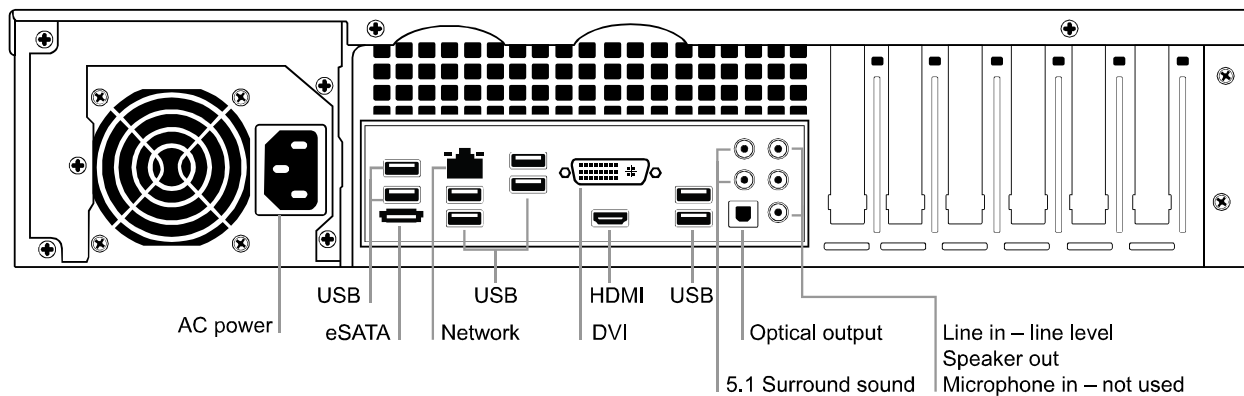



The rear panel of the NVR contains virtually all of the necessary connectors. Below is a diagram that outlines the location and description of each connector:



Getting Started

Identifying Included Components

Honeywell's Fusion NVRs come with a mouse, keyboard, selected software and cables. Identify the following components to make sure everything has been properly included with the new NVR. If any of the following items are missing, contact the dealer to arrange for a replacement.

 <p>NVR</p>	 <p>Mouse</p>	 <p>Keyboard</p>
 <p>DVR Repair/Software Disc</p>	 <p>Power Cord</p>	 <p>DVI-I to VGA adapter</p>

Keyboard Setup

To attach the keyboard to the recorder, plug the end of the Keyboard into a USB port located on the back of the machine.

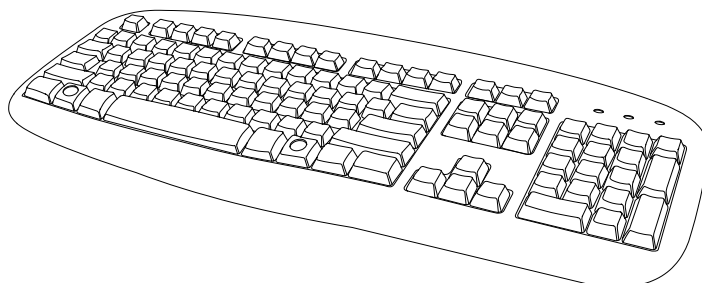

Mouse Setup

To attach the mouse to the recorder, plug the end of the mouse into a USB port located on the back of the machine.

The mouse uses a cursor called a pointer. Pointers come in many different shapes but are most commonly shaped like an arrow.

The mouse has two buttons: a left button and a right button. Quickly pressing and releasing one of these buttons is called clicking. Sometimes you will need to double-click – or click the same button twice quickly.

In this manual:

Click means to position the mouse cursor over an item and to single click the left button.

Right click means to position the mouse cursor over an item and to single click the right button.

Double-click means to position the mouse cursor over an item and to click the left button twice.

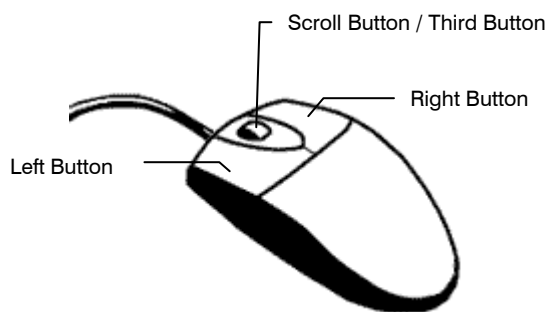

Select means to position the mouse cursor over a radio button, checkbox, or list item and click on it.

The scroll wheel in between the two buttons is used for added navigation functionality. By moving the wheel with index finger (scrolling), quickly move through multiple pages, lines, or windows. The wheel may also function as a third button allowing the user to quickly click or double-click an icon or a selected item



Monitor Setup

The recorder has the following connections available to attach a monitor.

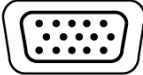
	HDMI Output	To TV / Digital Monitor
	DVI -I Output	To TV / Digital Monitor
	DVI to SVGA Adapter	Connect adapter to DVI output to connect an analog VGA Monitor.

Attach the monitor or monitors to the rear of the recorder using the cable supplied by the monitor manufacturer. Refer to the monitor manual for detailed information on how to setup and use it.

Note The monitor must be capable of having a screen resolution of 1024 x 768 and display colors of at least 32 Bit

Power Setup



WARNING:

To reduce the risk of electrical shock or damage to the equipment:

Do not disable the power grounding plug.
The grounding plug is an important safety feature.

If the electrical plug you are using does not have a ground plug receptacle contact a licensed electrician to have it replaced with a grounded electrical outlet.

Plug the power cord into a grounded (earthed) electrical outlet that is easily accessible at all times.

Disconnect the power from the computer by unplugging the power cord either from the electrical outlet or the computer.

Optional Components

To fully utilize the potential of the NVR, several optional Fusion components are listed below. Contact a dealer for more information.

- Internal RAID 5
- External RAID 5 Storage
- External SATA Storage
- SCSI Interface card
- Gigabit 10/100/1000 NIC Adapter
- Performance package upgrade
- Fusion Video Management Software
- Fusion Remote Video Software
- 2U NVR Rackmount Rails

Turning On the Recorder

Once the cables and adapters have been properly connected it is time to turn on the power. To turn on the power follow these steps:

1. Turn on the monitor and any external peripherals (ex. Printers, External Storage Devices, etc.) connected to the recorder.
2. Turn on the Secondary Power Switch located in the rear of the recorder.
3. Turn on the main power switch located on the front of the recorder.

The recorder will run a series of self-tests. After two or three minutes a series of messages may be displayed as the various hardware and software subsystems are activated. Under normal circumstances you should not be asked to respond to these messages. If you are asked to respond to the messages (adding a Printer, Monitor, etc for the first time) follow the instructions carefully.

After this finishes, the Fusion recorder software should load automatically and bring you to the main screen.

Turning Off the Recorder

To turn off the recorder, select the Exit button on the main screen and select Power Off. The recorder will safely shutdown, it may take several minutes to shut down completely.

Caution Always be sure to follow the proper procedures when turning off the power to the recorder. NEVER disconnect the power to the recorder while it is still running or in the process of shutting down. Doing so can cause data loss, file corruption, system instability and hardware failure

DVR Basics

Setting the Time and Date

1. Exit to Windows by clicking **Exit** on the Live View screen and selecting **Restart in Windows Mode**. (See the Live View screen section later in this chapter)
2. Open Windows Explorer. Do this by right-clicking the **My Computer** icon (located on the top left hand corner of the Desktop) and select **Explore**.
3. Click on **Control Panel** to open it. If you do not see Control Panel listed, Click **My Computer** to expand the folder tree.
4. Double-click **Date and Time** inside Control Panel.
5. Adjust the Date and Time.
6. When finished, close all open windows and restart the recorder.

Accessing the DVR Utility

Exporting DVR Settings

Exporting DVR settings can help configure multiple DVRs quickly or reconfigure a unit that has failed. Some things must be kept in mind when using this feature.

You cannot use this function on:

- DVRs that are different models.
- When upgrading from certain software versions. (This feature cannot be used when upgrading from v2.x to v3.x)

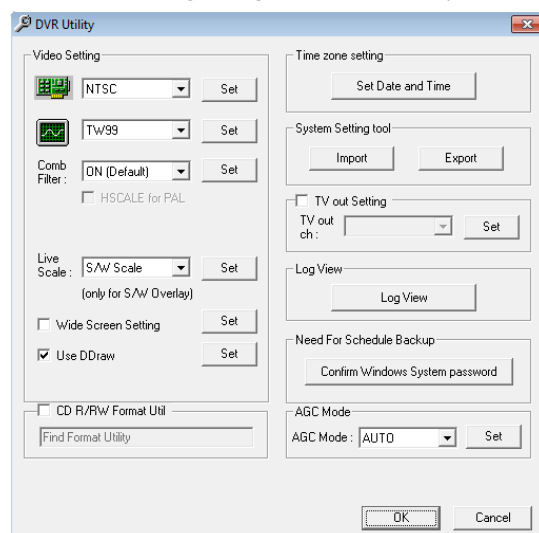

1. Exit to Windows by clicking **Exit** on the Live View screen then and select **Restart in Windows Mode**. (See the Live View screen section later in this chapter)
2. Open the **DVR Utility** window by clicking the **Start** button , clicking **All Programs**, clicking **Fusion**, and then clicking **vFormat**.
3. Click **Export** in the System Setting tool section.
4. Select a location to save the settings file and click **Save**. The DVR Utility will export the DVR settings and automatically close.

Importing DVR Settings

1. Exit to Windows by clicking **Exit** on the Live View screen then and select **Restart in Windows Mode**. (See the Live View screen section later in this chapter)
2. Open the **DVR Utility** window by clicking the **Start** button , clicking **All Programs**, clicking **Fusion**, and then clicking **vFormat**.
3. Click **Import** in the System Setting Tool section.
4. Select the location of the settings file to import and click **Open**.
5. Click **Yes** to import the data file.

Changing Video Format

1. Exit to Windows by clicking **Exit** on the Live View screen then and select **Restart in Windows Mode**. (See the Live View screen section later in this chapter)
2. Open the **DVR Utility** window by clicking the **Start** button , clicking **All Programs**, clicking **Fusion**, and then clicking **vFormat**.
3. Select the appropriate video setting from the list in the **Video Setting** section – NTSC or PAL..
4. Click **Set**.

Live View screen

Each time the recorder starts, the program defaults to the Live View screen. The following diagram outlines the buttons and features used on the Live View screen. You should become familiar with these options as this is the screen that will be displayed the majority of the time.

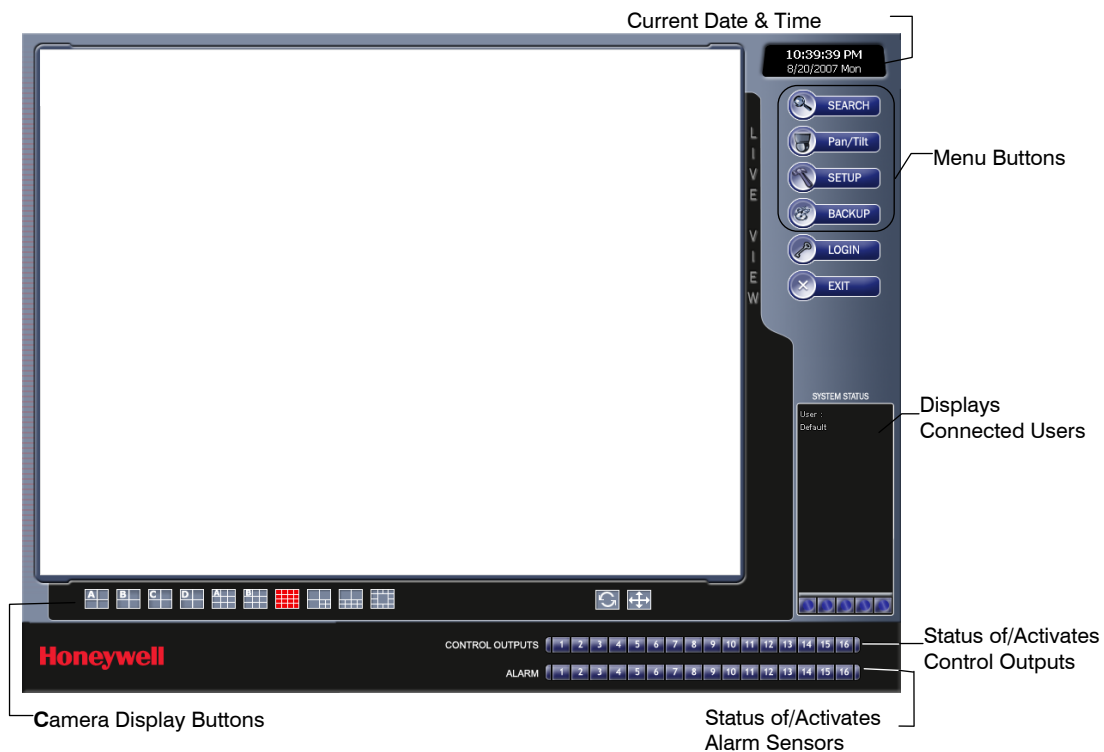

Live Camera Options

Right-click a camera on the Live View screen to display these options:

- Full Screen
- Instant Recording
- Search In Live
- Digital Zoom

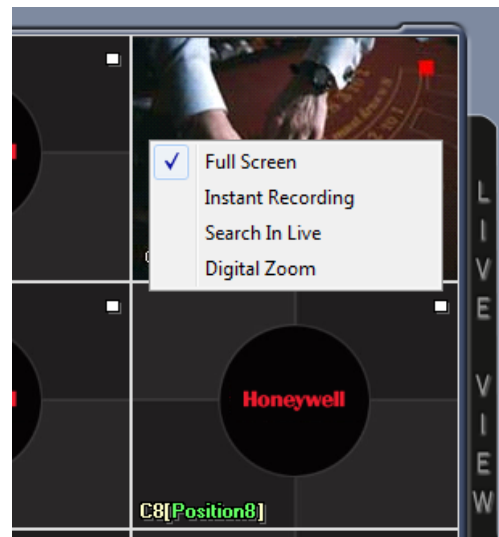

Camera View



Recording Status Indicator

The camera status for each camera is displayed in the upper right corner on the Video Display Area. The following are the different states for each camera:

- Recording** Displayed when the camera is currently being recorded to the recorder.
- Motion Detection** Displayed when a camera (set up for motion detection) detects motion.
- Display** Displayed when the camera is currently not being recorded to the recorder.





Special Recording

There are two types of Special Recording. Text is displayed on the camera indicating what type of Special Recording is activated.

- SENSOR** Sensor is displayed when a sensor, associated with a given camera, is activated.
- INSTANT** Instant Recording is a manual activation of the recording for the selected camera. Regardless of the recording method, Instant Recording will start the camera recording and also flag the video for future searches using the Index Search feature. INSTANT is displayed when a user activates the instant recording option. Double Right-Click the video display to activate and deactivate the Instant Recording option.

Screen Division Buttons

Note When viewing live video from Network Cameras, only 4CH will display at one time.

	Quad View	Displays cameras 1-4, 5-8, 9-12, 13-16, etc. in the Video Display Area.
	Nine Camera View	Displays cameras 1-9, 10-18, etc. in the Video Display Area.
	16 Camera View	Displays the first 16 cameras in the Video Display Area.
	Full Screen	Displays the current camera display configuration full screen.
	Auto-Sequence	Sequences through the Screen Divisions sets of 4, 9, or 16 cameras.

Dual Monitor Camera Display Menu

When dual monitors are enabled, you can adjust the camera display for live view on the secondary display. Move the mouse to the top of the screen and the camera display menu will appear.



Custom Live View Divisions

Customize your Live View screen by changing the order of the cameras. Each screen division can be individually customized but a camera can only be displayed once (once in 4 camera view, once in 9 camera view, etc). Both analog and IP video cameras can be moved.

Create custom live view divisions:

1. On the Live View screen click **Setup**, and then click the **General** tab.
2. Click **Sequence Setting**.
3. Drag and drop cameras from the Channel List to the desired location within the Division Group (4 Division, 9 Division, 16 Division).

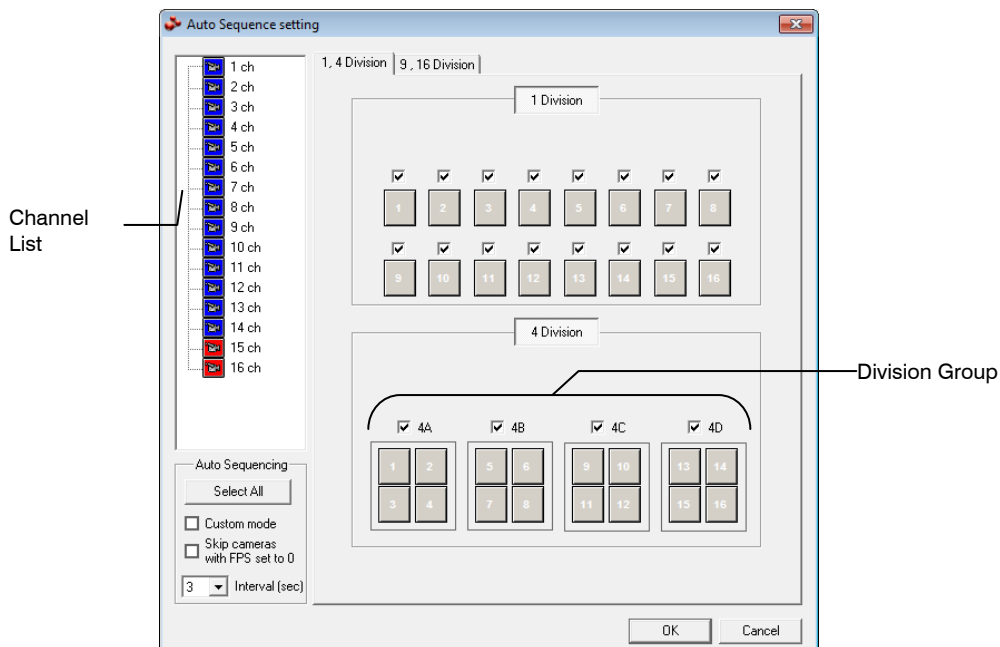

Setup Options

Setup Overview

The Setup options allow optimization of the DVR by adjusting things like camera names, recording schedules and more. It is extremely important to setup the DVR correctly for several reasons:

- **Recording Schedules** – Increase the amount of pertinent recorded video that is saved on the DVR by optimizing the recording schedule. Optimize the type of recording done by adding motion detection to this as well, again increasing the amount of useful video.
- **DVR Access** – By setting up the access passwords, the user has better control of the types of access any individual may have. This ensures the security and integrity of the DVR.
- **Camera Naming** – By naming each camera, the location and any other pertinent information can be easily identified when viewing it in the Video Display Area.

Setup Screen

Camera Setup

Assign names to each camera.

Network Video

Register and add network video devices, and adjust basic settings.

Motion

Create up to 15 video detection areas,

General

Configure display options, alerts, intensive recording

Recording Schedule

Create custom recording schedules for each channel, sensor, and special days.

Network

Assign network settings.

Administration

Set permissions for users, export logs, adjust HDD storage

Information

View version numbers, save contact numbers, and view available HDD status.

PTZ

Set up preset positions, tour and assign protocols.

Camera Setup

Displays live video from a selected camera

CAMERA SETUP allows you to name, adjust the brightness, hue and contrast for each camera.

Select Camera

Channel 1

Define camera name

Enter a name that is descriptive of the currently selected camera. This name may contain up to 14 characters.

Camera Name : Position1

For example: "Front Hallway" or "PTZ-07"

Set Up New Camera

1. Attach camera to the rear of the DVR chassis.
2. Click **Setup** on the Live View screen.
3. Click **Camera Setup** to open the **Camera Setup** display.
4. Select the channel that corresponds with the new camera from the **Select Camera** list.
5. Enter a name for the camera in the **Camera Name** box.
6. Click **Apply** when finished.

Network Video

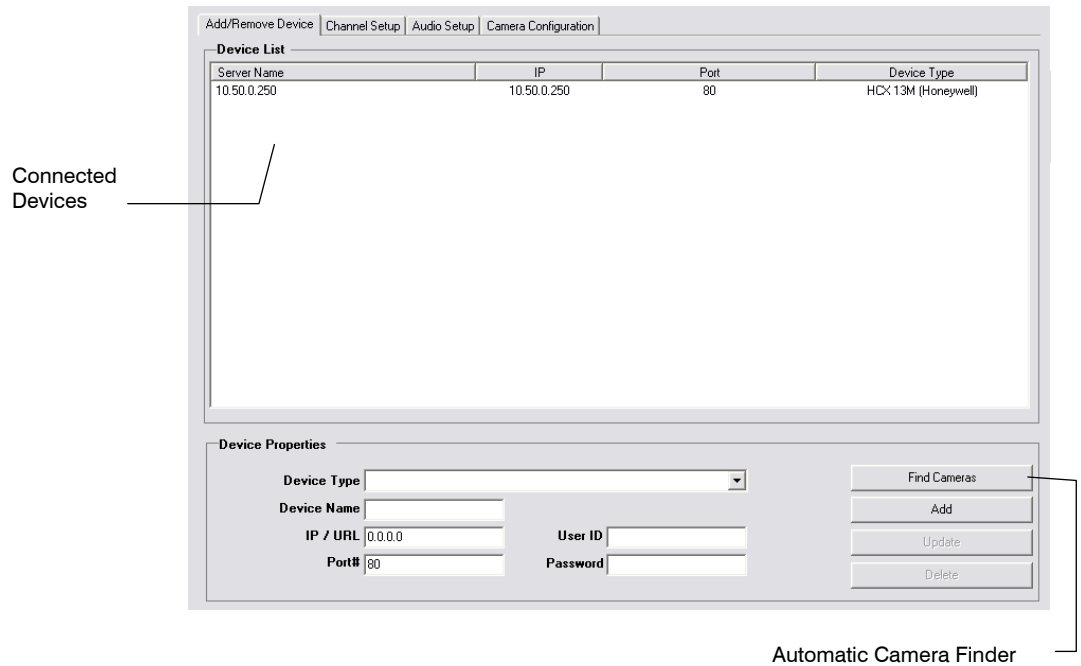

Connecting a Network Device

Note Refer to the EQUIP Series Network IP camera user guide for detailed information on setting up that camera using the Honeywell IP Utility application.

Connecting Manually

1. From the **Live View** screen, click **Setup**.
2. Click **Network Video**.
3. Click the **Add/Remove Device** tab.
4. Select your network device from the **Device Type** list.
5. Type a **Device Name**.
6. Type the **IP/URL address**, **Port#**, **User ID** and **Password** of the device.
7. Click **Add**.

Connecting with Camera Finder

1. From the **Live View** screen, click **Setup**.
2. Click the **Network Video** tab.
3. Click the **Add/Remove Device** tab.
4. Click **Find Cameras** to automatically find all connected Network cameras.
5. Select the check box next to the desired camera.
6. Click **Get Device**.
7. Type the **User ID** and **Password** of the device.
8. Click **Update**.

Assigning a Network Device to a Channel

Note Fusion IV recorders support single stream IP camera operation. Dual stream operation is not supported.

1. From the **Live View** screen, click **Setup**.
2. Click **Network Video**.
3. Click the **Channel Setup** tab.

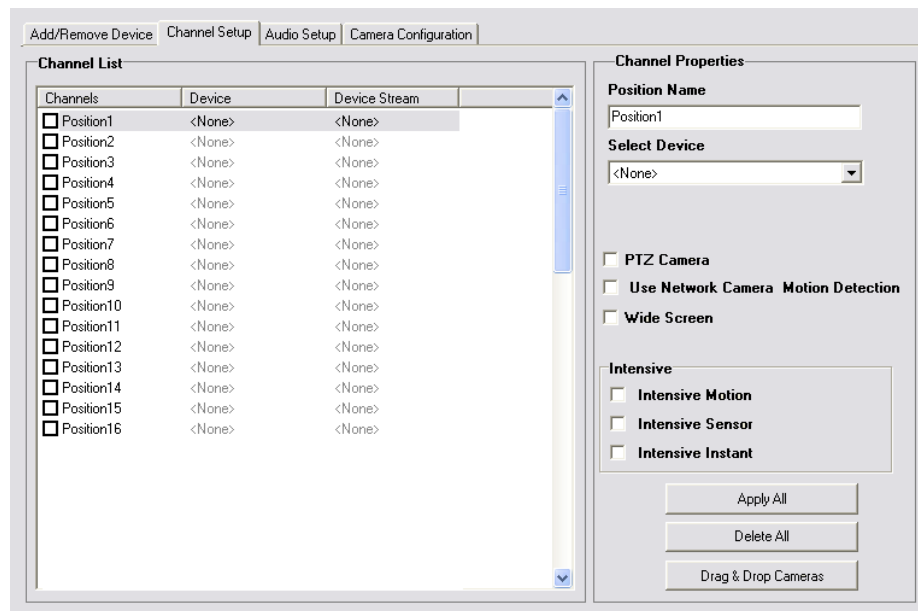

4. Click an available channel on the **Channel List**.
5. Type the desired **Position Name**.
6. On the **Select Device** list, select the appropriate network device added previously.
7. If the device has PTZ capabilities, select the **PTZ Camera** check box to enable.
8. If the device displays wide screen video, select the **Wide Screen** check box to allow it to display properly.
9. If supported, select the **Use Network Camera Motion Detection** check box.
10. Select **Intensive Motion**, **Intensive Sensor**, and/or **Intensive Instant** to increase the recording rate on an event.
11. Click **Apply** to save your selections.

Assigning Audio Channels to a Network Device

1. From the **Live View** screen, click **Setup**.
2. Click **Network Video**.
3. Click the **Audio Setup** tab.

The screenshot shows the 'Audio Setup' configuration window. At the top, there are tabs for 'Add/Remove Device', 'Channel Setup', 'Audio Setup', and 'Camera Configuration'. The 'Audio Setup' tab is active. The window is divided into two main sections: 'Channel List' on the left and 'Channel Properties' on the right.

Channel List: A table with three columns: 'Channels', 'Device', and 'Device Channel'. It contains 16 rows, each representing a channel position. The first row, 'Position1', is selected with a checked checkbox and has 'Network Camera' in the 'Device' column and '<None>' in the 'Device Channel' column. All other positions (2-16) have unchecked checkboxes and '<None>' in both the 'Device' and 'Device Channel' columns.

Channels	Device	Device Channel
<input checked="" type="checkbox"/> Position1	Network Camera	<None>
<input type="checkbox"/> Position2	<None>	<None>
<input type="checkbox"/> Position3	<None>	<None>
<input type="checkbox"/> Position4	<None>	<None>
<input type="checkbox"/> Position5	<None>	<None>
<input type="checkbox"/> Position6	<None>	<None>
<input type="checkbox"/> Position7	<None>	<None>
<input type="checkbox"/> Position8	<None>	<None>
<input type="checkbox"/> Position9	<None>	<None>
<input type="checkbox"/> Position10	<None>	<None>
<input type="checkbox"/> Position11	<None>	<None>
<input type="checkbox"/> Position12	<None>	<None>
<input type="checkbox"/> Position13	<None>	<None>
<input type="checkbox"/> Position14	<None>	<None>
<input type="checkbox"/> Position15	<None>	<None>
<input type="checkbox"/> Position16	<None>	<None>

Channel Properties: This panel contains a 'Select Device' dropdown menu currently set to '<None>'. Below it are two checkboxes: 'Record Network Audio' and 'Enable Network Audio in Live View', both of which are currently unchecked. At the bottom of the panel are three buttons: 'Apply All', 'Delete All', and 'Drag & Drop Cameras'.

4. Click an available audio channel on the **Channel List**.
5. On the **Select Device** list, select a network device added previously.
6. To record the network audio select the **Record Network Audio** check box. The audio channel will be available on the search screen.
7. To access the audio channel from the Live View screen, select the **Enable Network Video in Live View** check box.

Camera Configuration

The Camera Configuration tab displays information on all cameras (analog and network) connected to the Fusion recorder

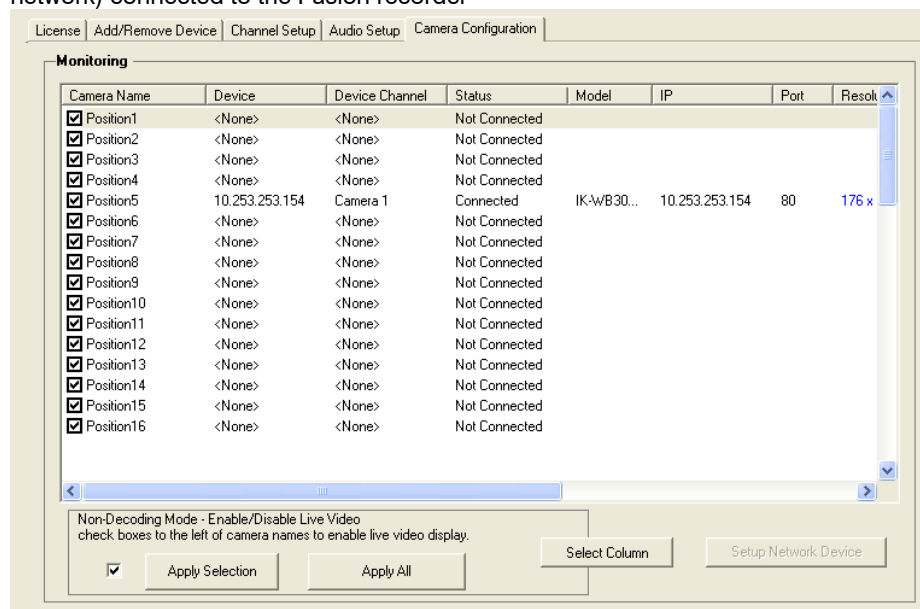

Enable/Disable Live Video

- To enable a network device to display as live video select the check box next to the **Camera Name** that you want available for live video display.
- To disable live video for a network device, clear the check box next to the **Camera Name**.

Displaying More Columns

The Camera Configuration tab can be customized to display the information you use most. Click **Select Column** to add or remove specific columns.

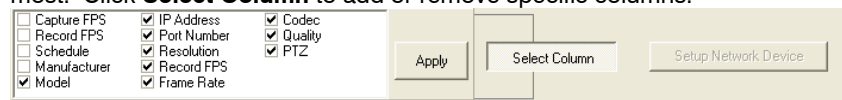

- | | | |
|---------------------|--------------------|----------------|
| Capture FPS | IP Address | Codec |
| Record FPS | Port Number | Quality |
| Schedule | Resolution | PTZ |
| Manufacturer | Record FPS | |
| Model | Frame Rate | |

Accessing the Configuration Menu

Use the Fusion interface to access basic network device menu functions.

1. From the **Live View** screen, click **Setup**.
2. Click **Network Video**.
3. Click the **Camera Configuration** tab.
4. Highlight the desired camera.
5. Click **Setup Network Device**.

Motion Setup

The recorder allows the user to adjust several different Motion Settings and create motion detection areas.

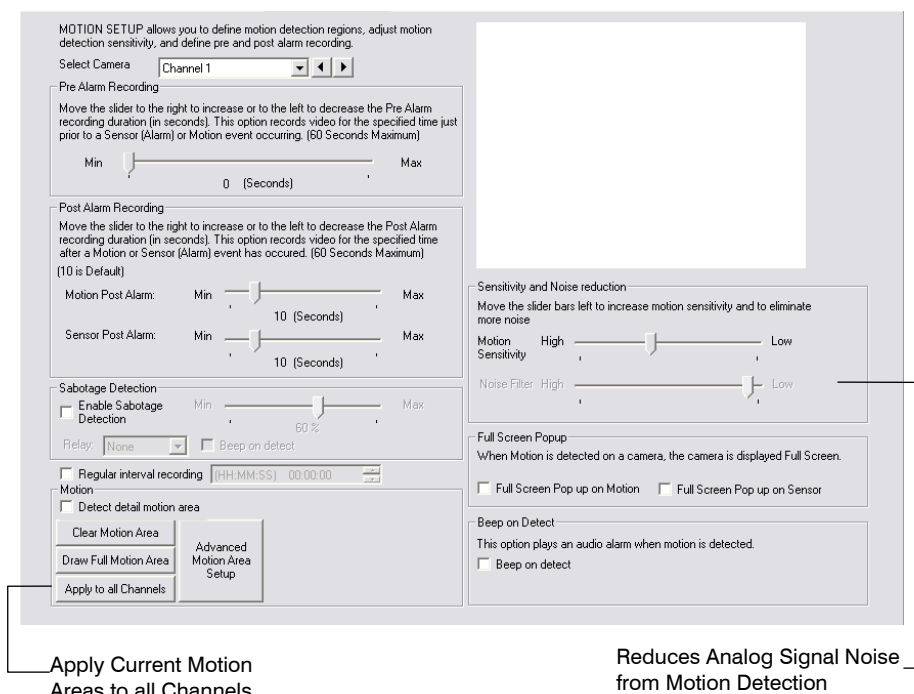

Regular Interval Recording

Regular Interval Recording allows users to record a single frame every few minutes or hours even when there is no motion. This option is only available when Motion recording is selected in the recording schedule.

To enable Regular Interval Recording:

1. Select the **Regular Interval Recording** check box.
2. Specify how often to take an image when no motion is occurring. System can be set to as many as one image per second.

Enable Sabotage Detection

The Camera Sabotage Detection feature will notify users that the field of vision of a camera has been compromised, abruptly changed, or detects significant vibration. To enable Sabotage Detection:

1. Select the **Enable Sabotage Detection** check box.
2. Set the threshold percentage to reduce false alarms.
3. Select the **Beep on Detect** check box – or – select a Relay to activate on detection.

Create a Motion Area

1. Click **Motion** in **Setup**.
2. Select a camera from the **Select Camera** list.
3. Select the **Detect Detail Motion Area** check box.
4. Click **Clear**.
5. Click **Advanced Motion Area Setup**.
6. Click a **Motion Detection Area** shape button.

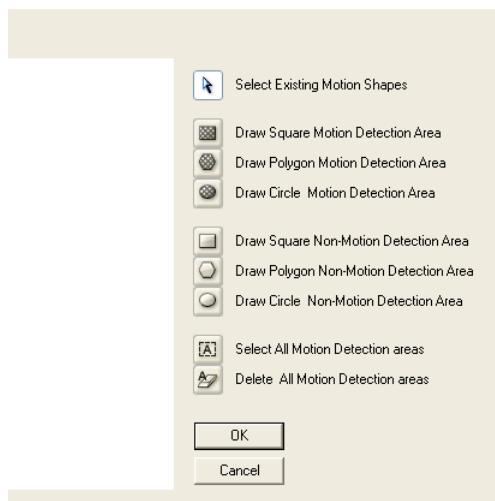

7. Drag the mouse over the camera image.

Note To create a polygon shape, click the mouse at each point and double-click to close the shape.

8. Click **OK**.
9. Move the sliders to adjust motion sensitivity and the noise filter.
10. Define the pre-alarm and post-alarm recording time for a motion event.

Pre Alarm – 0 > 50 Seconds [The number of seconds the recorder records before motion is detected]

Post Alarm (MOTION) – 0 > 50 Seconds [The number of seconds the recorder records after motion is detected]

General Setup

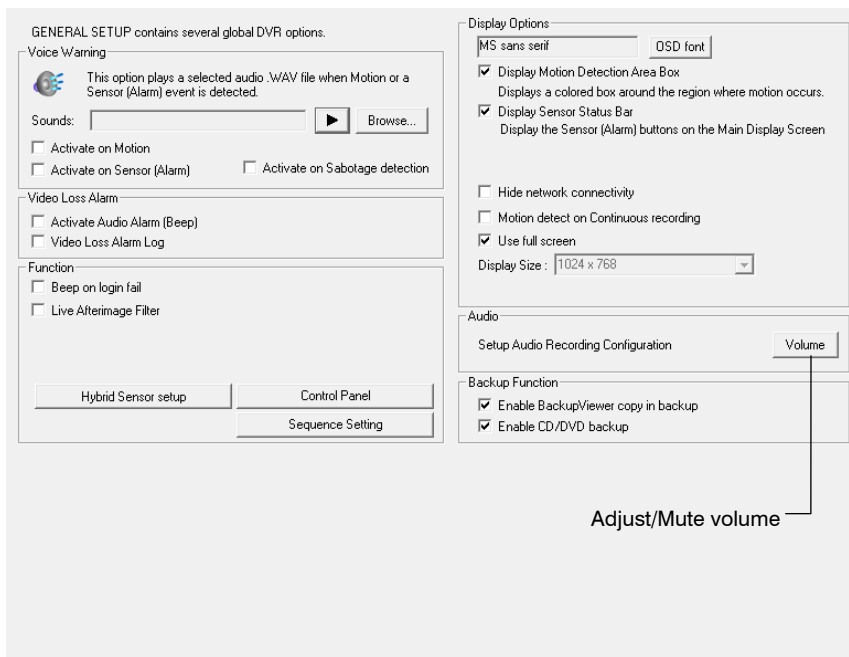

Function

Beep on Login Fail Enables the DVR to beep continuously in response to a failed login attempt. Only an authorized login will stop the beeping.

Sequence Setting Allows the video out picture to automatically cycle through channels at a set speed. Example: .Cycle through channels 1-6 at four-second intervals.

Display Options

Use Full Screen Stretch the Fusion software to use the full monitor screen.

Display Size Select from available monitor display sizes. Use to correctly display video on wide screen monitors.

Motion Detect on Continuous recording Allows you to process and receive motion events and alarms while recording in continuous mode. Also enhances search capabilities when recording in continuous

Note Motion Detect on Continuous is not supported on IP cameras.

Voice Warning

The recorder allows users to play a sound file when either a Motion event or Sensor event occurs. This file can be a custom created sound file that is unique to the application. The selected WAV file is played through speakers attached to the recorder.

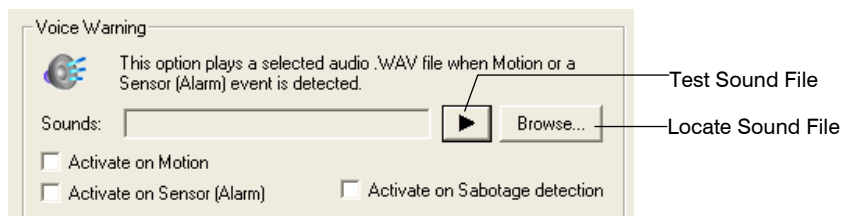

1. Click the **Open Sound File** icon to browse for a WAV file. The selected file will display in the box on the left.
2. Click the **Test** icon to verify the audio file.
3. Select **Activate on Motion**, **Activate on Sensor (Alarm)**, and or **Activate on Sabotage Detection** to trigger the audio file.

Video Loss Alarm

The DVR supports a Video Loss Alarm function which allows an Alarm Event to occur when a camera loses its signal. The lost signal can be due to camera power failure to the camera, the camera cable being cut or unplugged, or the camera being damaged in some way.

In order to use Video Signal Loss detection, cameras must either be Enabled or Disabled. This is because the DVR needs to know which cameras it should expect to receive signals from. To enable camera(s), open Frame Setup, and set the Images Per Second to anything above zero. By designating zero images per second the camera will not be used by the DVR.

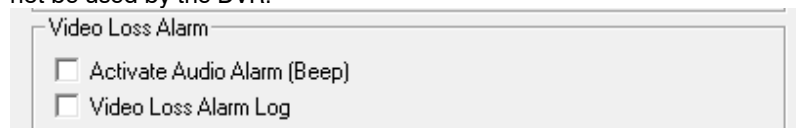

Activate Audio Alarm (BEEP)

When video loss occurs, an internal speaker on the DVR will sound an alarm.

Video Loss Alarm Log

When video loss occurs, the event is recorded in the DVR log.

Volume

The volume control allows fine tuning of the volume settings on the recorder.

Volume Options:

- **Speakers** – Used to adjust the volume for all sound coming from the system's speakers
- **System Sounds** – Used to adjust the volume for the system sounds exclusively.

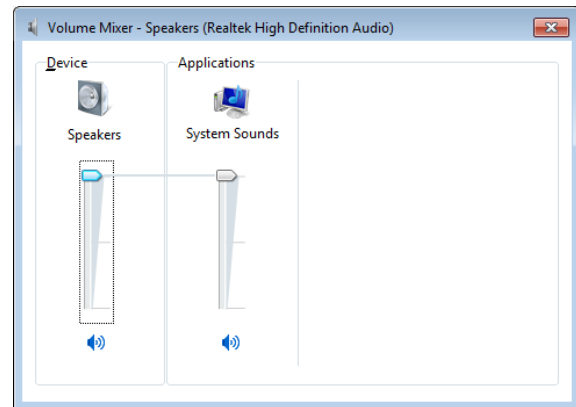

Connecting to a Wide Screen Display

1. Click **Exit** on the Live View screen and select **Exit in Windows Mode**.
2. Right-click the Desktop and select **Screen Resolution**.
3. From the **Resolution** list, select the proper resolution of the connected display.

Tip Refer to the display documentation for the proper resolution settings.

4. Click **OK** and confirm the change.
5. Double-click the **Fusion Server** icon on the Desktop.
6. Click **Setup** on the Live View screen and then click **General**.
7. Under **Display Settings**, select the **Use Full Screen** check box and then select the correct resolution from the **Display Size** list.
8. Click **Apply**.

Connecting a Second Monitor

1. Click **Exit** on the Live View screen and select **Exit in Windows Mode**.
2. Right-click the Desktop and select **Screen Resolution**.
3. Click the secondary Live View screen and from the **Multiple displays** list click **Extend these displays**.
4. Click **Apply**.
5. On the **Resolution** list, select the proper resolution of the connected display.

Tip Refer to the display documentation for the proper resolution settings.

6. Click **OK** and confirm the change.
7. Double-click the **Fusion Server** icon on the Desktop.
8. Click **Setup** on the Live View screen and then click **General**.
9. Under **Function**, select the **Dual Monitor** check box.
10. Click **Apply**.

Auto Sequence Setting

Auto Sequencing is available either in the Live View screen when Auto Sequencing has been enabled or when a Spot-Monitor out signal is used to display on a spot monitor. Auto Sequencing conveniently displays video channels at specified intervals and sequences through each selected channel.

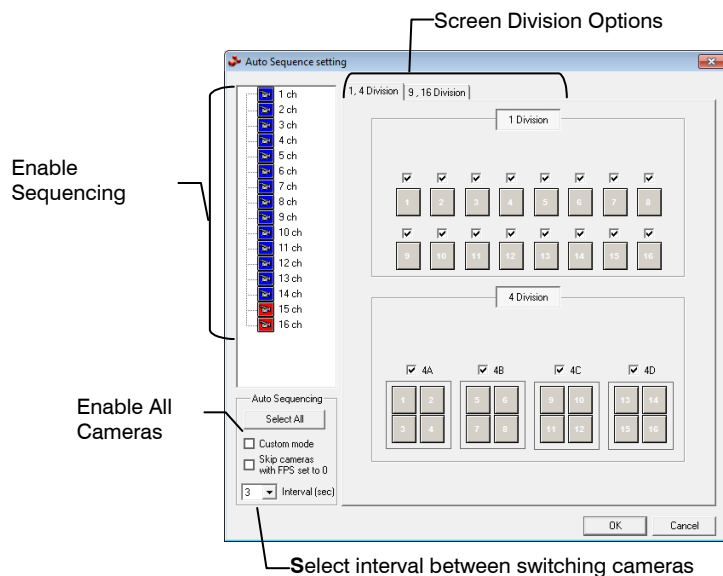

Custom Mode

Create non-standard screen divisions

Skip 0 FPS Channel

Sequence skips cameras with no video signal

Create Custom Auto Sequence

1. Open **General** setup and click **Sequence Setting**.
2. Click individual cameras in the left pane or click **Select All** to include all cameras in the sequence.
3. Select an **Interval** time (in seconds) to display each screen in the sequence.
4. Select screen division options for appropriate cameras.

Hybrid Sensor Setup

This interface is used to link Hard Contact Sensor Inputs from supported Network Devices to the recorder software.

Network Device Sensor Setup

Network Device Sensor Setup

* Network Device List (Select a device.)

Address (Port)	Model (Type)	Sensor count	Relay count

* Sensor / Relay list

Sensor count	DVR Sensor No	Relay	DVR Relay No

Apply Close

Schedule Setup

Creating a customized schedule is important to maximize the efficiency of the recorder. The Fusion recorder offers numerous options to allow for a wide variety of different needs and requirements.

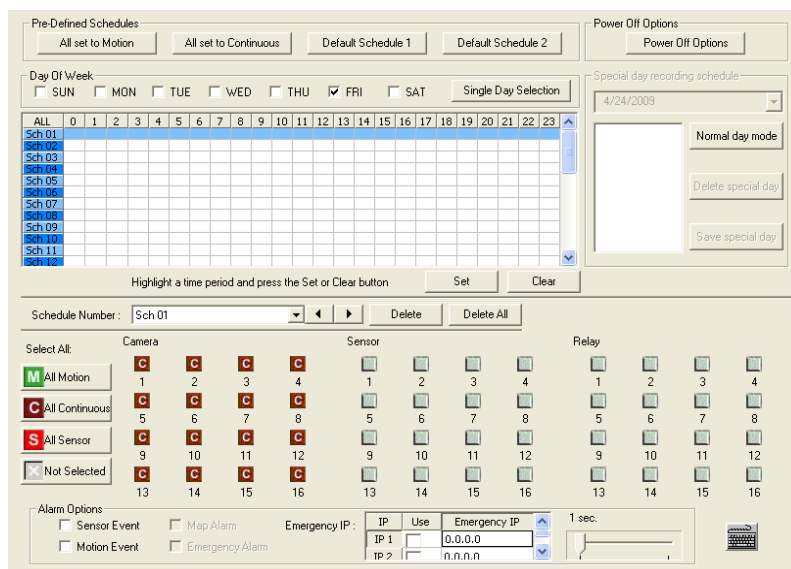

Schedule Number	The Schedule Number is a group of settings. Up to 32 schedules can be created. Think of the schedules as transparency paper with words written on them. When placed one on top of another, the words can still be seen from the layers below. These schedules allow a powerful detailed recording schedule to be created.
Special Day Recording Schedule	Customize a schedule for a particular day, such as a Parade Day, Holiday, etc.
Alarm Options	These are advanced options that send alarm events (either motion or sensor) to the remote alarm monitor software and FVMS. Tip To send motion events to FVMS, select both Motion Event and Map Alarm check boxes.
Power Off Options	Allows the user to specify time frames for turning off and restarting the DVR automatically.

Default Schedules

Default Schedule 1

All cameras are set to: 8AM-5PM. Continuous recording 5PM-8AM Motion recording

Default Schedule 2

All cameras are set to: Motion recording 24 hours/day, 7 days/week.

Camera 1 associated to sensor input 1

Camera 2 associated to sensor input 2

Camera 3 associated to sensor input 3, etc.

Note Default Schedule 1 and Default Schedule 2 are not configured for use with sensors/alarms.

Day of the Week

The Day of Week is the day of the week for which the schedule is being edited. If WED is checked, Wednesday's schedule is being edited.

The Single Selection Mode button allows selection of multiple days at once.

By selecting the Single Selection Mode button placing multiple checks in the boxes is allowed, thereby selecting multiple days simultaneously.

Day Of Week

SUN MON TUE WED THU FRI SAT

Clicking on Single Selection Mode will change the button to Multi Selection Mode. This allows you to select multiple days to configure at once.

Creating a Simple Schedule (By Example)

Creating schedules is easy with a little experience. In the following example, the steps for creating a simple schedule for cameras 1 to 4 are detailed.

The schedule will be as follows:

- MON-FRI (9AM-5:59PM) all 4 cameras will record using MOTION recording.
- MON-FRI (6PM-8:95AM) all 4 cameras will record using CONTINUOUS recording.
- SAT-SUN (12AM-11:59PM) all 4 cameras will record using MOTION recording.

Using these examples, a total of 3 schedules will be created.

Steps 1-6: Schedule cameras 1-4 to record on MOTION from 9:00am-5:59pm Monday through Friday.

1. Select **Sch01** from the **Schedule Number** list. (This should already be selected by default)
2. Click the **Single Selection Mode** button.
3. Select the MON, TUE, WED, THU, and FRI days of the week check boxes.
4. On the **Sch01** line on time selector grid, highlight hours 09-17. Click **Set**.
5. Click **Camera** buttons 1-4 until the green Motion buttons are selected.
6. Click **Apply** to save.

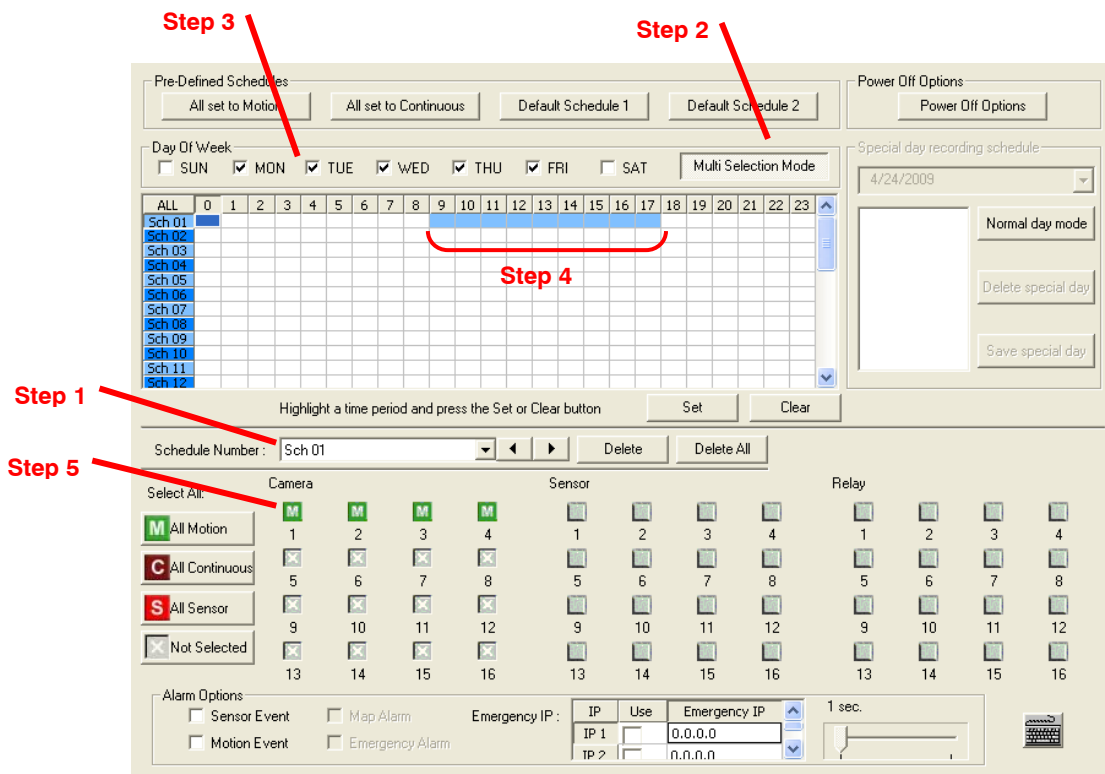

Steps 7-11: Schedule cameras 1-4 to record on CONTINUOUS from 6:00pm-8:59am Monday through Friday.

1. Select **Sch02** from the **Schedule Number** list.
2. On the **Sch02** line again, highlight the hours 18-23 (for 6:00pm-midnight) and click **Set**.
3. On the **Sch02** line on time selector grid, highlight the hours 00-08 (for midnight to 8:59am) and click **Set**.
4. Click **Camera** buttons 1-4 until the maroon Continuous buttons are selected.
5. Click **Apply** to save.

The screenshot shows the 'Pre-Defined Schedules' configuration window. At the top, there are buttons for 'All set to Motion', 'All set to Continuous', 'Default Schedule 1', and 'Default Schedule 2'. Below this is a 'Day Of Week' section with checkboxes for SUN, MON, TUE, WED, THU, FRI, and SAT, and a 'Multi Selection Mode' dropdown. The main area is a grid with rows for 'Sch 01' through 'Sch 12' and columns for hours 0-23. Red arrows indicate the following steps:

- Step 7:** Points to the 'Set' button at the bottom of the grid.
- Step 8:** Points to the highlighted hours 18-23 on the 'Sch 02' row.
- Step 9:** Points to the highlighted hours 00-08 on the 'Sch 02' row.
- Step 10:** Points to the 'All Continuous' button in the 'Select All' section.

Below the grid, there is a 'Schedule Number' dropdown set to 'Sch 02', and buttons for 'Delete' and 'Delete All'. The 'Select All' section includes buttons for 'All Motion' (M), 'All Continuous' (C), 'All Sensor' (S), and 'Not Selected' (X). Below this is a table for selecting cameras and sensors:

Select All:	Camera				Sensor				Relay			
<input checked="" type="checkbox"/> All Motion	<input checked="" type="checkbox"/> 1	<input checked="" type="checkbox"/> 2	<input checked="" type="checkbox"/> 3	<input checked="" type="checkbox"/> 4	<input type="checkbox"/> 1	<input type="checkbox"/> 2	<input type="checkbox"/> 3	<input type="checkbox"/> 4	<input type="checkbox"/> 1	<input type="checkbox"/> 2	<input type="checkbox"/> 3	<input type="checkbox"/> 4
<input checked="" type="checkbox"/> All Continuous	<input checked="" type="checkbox"/> 5	<input checked="" type="checkbox"/> 6	<input checked="" type="checkbox"/> 7	<input checked="" type="checkbox"/> 8	<input type="checkbox"/> 5	<input type="checkbox"/> 6	<input type="checkbox"/> 7	<input type="checkbox"/> 8	<input type="checkbox"/> 5	<input type="checkbox"/> 6	<input type="checkbox"/> 7	<input type="checkbox"/> 8
<input type="checkbox"/> All Sensor	<input checked="" type="checkbox"/> 9	<input checked="" type="checkbox"/> 10	<input checked="" type="checkbox"/> 11	<input checked="" type="checkbox"/> 12	<input type="checkbox"/> 9	<input type="checkbox"/> 10	<input type="checkbox"/> 11	<input type="checkbox"/> 12	<input type="checkbox"/> 9	<input type="checkbox"/> 10	<input type="checkbox"/> 11	<input type="checkbox"/> 12
<input checked="" type="checkbox"/> Not Selected	<input checked="" type="checkbox"/> 13	<input checked="" type="checkbox"/> 14	<input checked="" type="checkbox"/> 15	<input checked="" type="checkbox"/> 16	<input type="checkbox"/> 13	<input type="checkbox"/> 14	<input type="checkbox"/> 15	<input type="checkbox"/> 16	<input type="checkbox"/> 13	<input type="checkbox"/> 14	<input type="checkbox"/> 15	<input type="checkbox"/> 16

At the bottom, there are 'Alarm Options' including 'Sensor Event', 'Map Alarm', 'Motion Event', and 'Emergency Alarm'. There is also an 'Emergency IP' section with fields for IP 1 (0.0.0.0) and IP 2 (0.0.0.0), and a '1 sec.' timer.

Steps 12-17: Schedule cameras 1-4 to record on MOTION from 12:00am-11:59pm Saturday and Sunday

1. Select **Sch03** from the **Schedule Number** list.
2. Select the **SAT** and **SUN** check boxes.
3. Clear all other **Day of Week** check boxes
4. On the **Sch03** line on the time selector grid, highlight hours 00-23 and click the **Set** button.
5. Click **Camera** buttons 1-4 until the Green Motion buttons are selected.
6. Click **Apply** to save.

Step 13 & 14

Step 15

Step 12

Step 16

The screenshot shows the 'Pre-Defined Schedules' window. At the top, there are buttons for 'All set to Motion', 'All set to Continuous', 'Default Schedule 1', and 'Default Schedule 2'. Below this is the 'Day Of Week' section with checkboxes for SUN, MON, TUE, WED, THU, FRI, and SAT. The 'SUN' and 'SAT' checkboxes are checked. A 'Multi Selection Mode' button is also present. The main area is a grid with columns for hours 0-23 and rows for schedules Sch 01 through Sch 12. The row for Sch 03 is highlighted in blue, and a red arrow labeled 'Step 15' points to this row. Below the grid are 'Set' and 'Clear' buttons. At the bottom, there is a 'Schedule Number' dropdown set to 'Sch 03', and a table for selecting camera, sensor, and relay options. The 'Camera' section has four buttons: 'All Motion' (green with 'M'), 'All Continuous' (red with 'C'), 'All Sensor' (red with 'S'), and 'Not Selected' (grey with 'X'). The 'All Motion' button is selected. Below the table are 'Alarm Options' and 'Emergency IP' settings.

Scheduling Sensors and Relays (By Example)

It is easy to add advanced recording functionality using Sensor Inputs.

SENSOR - Sensor Inputs can be programmed to instantly start one or more cameras recording when an alarm occurs.

Note You must first associate the software sensors with the sensors (click Hybrid Sensor Setup on the General tab).

The schedule example will be as follows:

- SUN-SAT (12AM-11:59PM) Cameras 1 and 2 will be activated on Sensor #3 and/or Sensor #5.

Steps 1-7: Schedule cameras 1 and 2 to be activated on Sensor # 3 and/or Sensor #5.

1. Select **Sch01** from the **Schedule Number** list. (This should already be selected by default.)
2. Click the **Single Day Selection** button.
3. Select the **SUN, MON, TUE, WED, THU, FRI, and SAT** check boxes.
4. On the **Sch01** line (time selector grid), highlight the hours 00-23 and click **Set**.
5. Click **Camera** buttons #1 and #2 until the Red Sensor buttons are selected.
6. Click **Sensor** buttons #3 and #5.
7. Click **Apply** to save.

The screenshot shows the 'Pre-Define Schedules' window. At the top, there are buttons for 'All set to Motion', 'All set to Continuous', 'Default Schedule 1', and 'Default Schedule 2'. Below this is the 'Day Of Week' section with checkboxes for SUN, MON, TUE, WED, THU, FRI, and SAT, all of which are checked. A 'Multi Selection Mode' dropdown is also present. The main area is a grid for selecting time periods for various schedules (Sch 01 to Sch 12). A red arrow labeled 'Step 4' points to the 'Set' button at the bottom of the grid. Below the grid, there is a 'Schedule Number' dropdown set to 'Sch 01' and buttons for 'Delete' and 'Delete All'. The 'Camera' and 'Sensor' selection area shows buttons for 'All Motion', 'All Continuous', 'All Sensor', and 'Not Selected', with a grid of buttons for cameras 1-4 and sensors 1-16. Red arrows labeled 'Step 5' and 'Step 6' point to the 'All Motion' and 'All Sensor' buttons respectively. At the bottom, there are 'Alarm Options' including 'Sensor Event', 'Motion Event', 'Map Alarm', and 'Emergency Alarm', along with an 'Emergency IP' field and a '1 sec.' duration setting. Red arrows labeled 'Step 1' and 'Step 2' point to the 'Set' and 'Multi Selection Mode' buttons respectively. A red arrow labeled 'Step 3' points to the 'Day Of Week' checkboxes.

Verifying a Recording Schedule

1. Select a single day of the week using the selection check box to the left of the specified day.
2. Identify the schedule (or schedules) that have specific hours of the day highlighted in light blue color. The horizontal axis of the schedule grid corresponds to the 24 hours of each day.
3. After verifying that all hours of the selected day are covered by at least one of the 32 independent schedules (vertical axis of schedule grid) now look to the lower half of the schedule interface.
4. In the **Schedule Number** list, select the schedule(s) that were defined above for the current day and verify, in each schedule number, that the correct cameras are set to Continuous, Motion or Sensor based recording.

Note If a specific camera should not be recorded on a given day/schedule combination, set the camera to "Not Selected" - a white "X".

5. Repeat this process for each of the 7 days of the week until certain that the desired recording method is configured for each day.

Network Setup

Network Setup allows the user to adjust settings such as Ports, setup emergency PPP information for use with the Emergency Agent and enable Remote Access.

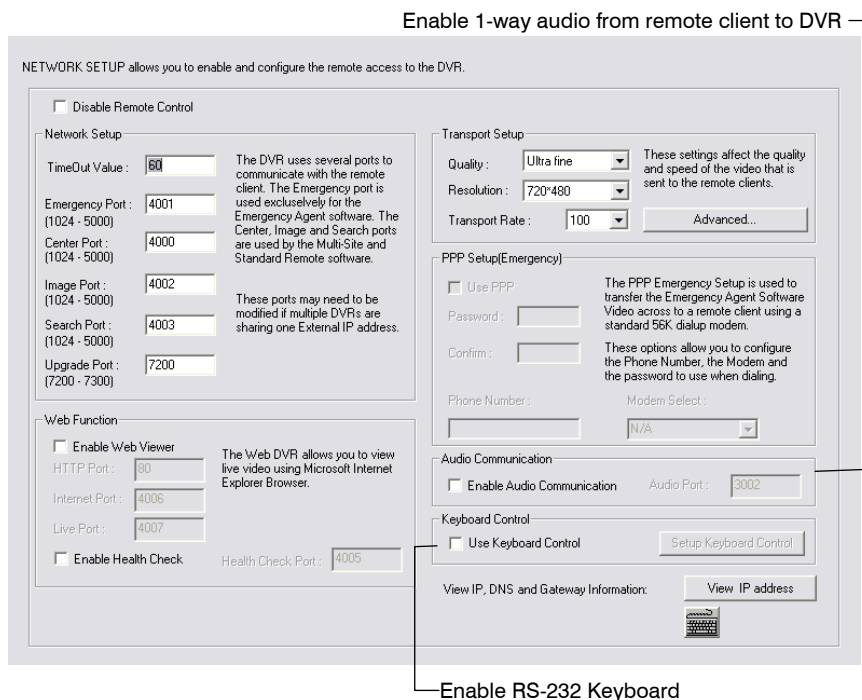

Network Setup

Time Out Value

When attempting to connect to the DVR, if the connection does not succeed during the timeout period (seconds), the connection will be terminated.

Emergency Port

Used to connect to the Alarm Monitor software.

Center Port

Used to connect to the Fusion remote software. This port must be specified in the Fusion Remote Software to connect to the DVR.

Image Port

Used to transfer the video to the Fusion remote software.

Search Port

Used to transfer search information to the Fusion remote software.

Upgrade Port

Used to upgrade software via a remote connection.

Note If connecting to the DVR through a firewall, the above ports must be open to incoming and outgoing traffic.

Web Function

- HTTP Port** Used to transfer the DVR Interface via the Internet to the Web Viewer. Default 80.

- Internet Port** Used for Data communication between the DVR and the Web Viewer. Default 4006.

- Live Port** Used to transfer video via the Internet when Web Viewer is enabled. Default 4007.

- Health Check Port** Enables FVMS to receive information regarding the health of the DVR.

- Resolution** By setting the resolution low, the images will be sent faster, however, the image quality will be reduced considerably. When set to Original, full quality video will be sent [720 x 480 (NTSC) 720 x 576 (PAL)]. The Original setting is very bandwidth intensive.

Transport Setup

- Transport Rate** Throttles the bandwidth on the DVR. This option is based on percentages of images sent. These settings affect the quality and speed of the video that is sent to the remote clients.

- Advanced** Configure the Transmit size on a per channel basis.

Administration

The screenshot shows the 'ADMINISTRATION' interface with several sections:

- User Management:** Includes a 'User Management' button for creating and configuring user accounts.
- Storage Management:** Includes buttons for 'Disk Management', 'Status Check/Email', and 'File Information'.
- Other Management:** Includes a 'Program Management(ETC)' button.
- System Log:**
 - A calendar for 'March 2011' with a red '4' on the 4th, labeled 'Select Date'.
 - 'Log Type' section with radio buttons for 'System Log' (selected), 'Event Log', 'Alarm Log', and 'Drive Check Log'.
 - 'Export' section with 'Choose 1-week period to export', 'Start Date' and 'End Date' dropdowns (both set to 3/11/2011), and buttons for 'Export log data (Text)' and 'Export log data (Raw)'. A 'Log Management' button is also present.
 - 'Pages' dropdown set to 'Page 1(00001 ~ 01000)' and 'Total log size' of 4.55 KB.
 - A table of log entries with columns: NO, Date & Time, Log Contents, Log Value, and User.

The log data table is labeled 'Log Data' and contains the following entries:

NO	Date & Time	Log Contents	Log Value	User
1	3/11/2011 15:26:3...	Start Site	Ver(4.5.0 [Build : 24]) - Lib(2.0.2.2)	Default
2	3/11/2011 15:26:3...	First Start Site		Default
3	3/11/2011 15:26:3...	Timezone information	Pacific Standard Time	Default
4	3/11/2011 15:26:3...	Nero Initialize	7.2.3.3	Default
5	3/11/2011 15:26:3...	Open Fail (SerialPort)	Port: COM1, Error Code: 6	Default
6	3/11/2011 15:27:3...	Terminate of Site		admini...
7	3/11/2011 15:44:0...	Start Site	Ver(4.5.0 [Build : 24]) - Lib(2.0.2.2)	Default
8	3/11/2011 15:44:0...	Start Site After Normal terminate		Default
9	3/11/2011 15:44:0...	Timezone information	Pacific Standard Time	Default
10	3/11/2011 15:44:0...	Nero Initialize	7.2.3.3	Default
11	3/11/2011 15:44:0...	Open Fail (SerialPort)	Port: COM1, Error Code: 6	Default
12	3/11/2011 15:44:4...	Terminate of Site		admin

Export Log Data (1 to 7 days)

Disk Management

The Disk Management window is a native Windows function. This window displays the partition scheme and health status of the Hard Disk Drives in the recorder. This window is often used to troubleshoot a recorder, or verify the amount of Hard Drive storage installed. For more information about Disk Management, consult a Windows 7 manual.

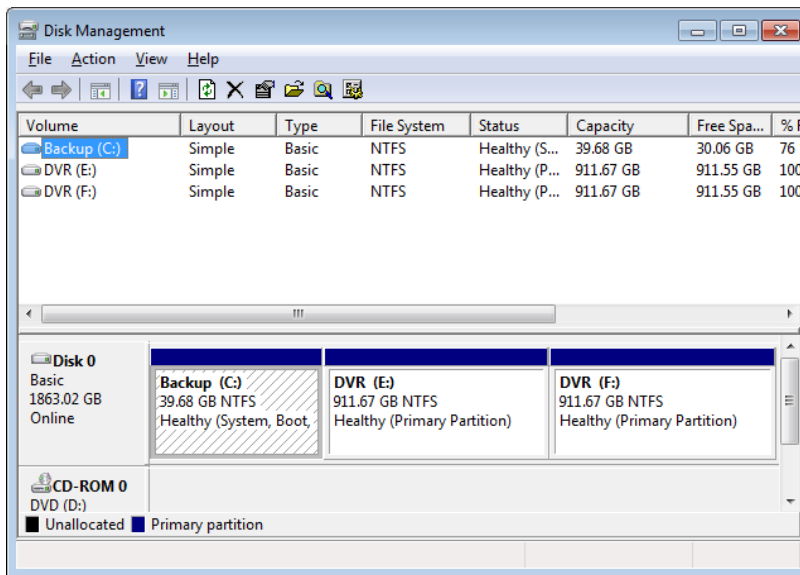

Setting up DDNS

Dynamic Domain Name System (DDNS) is a service that provides a static address to simplify remote connection to the recorder. This service is most useful for installations where the WAN (public) IP address is dynamic (changes from time to time). Most public IP addresses are dynamic unless a static address has been specifically ordered from the internet service provider.

Enable DDNS

To enable this functionality of the recorder, follow the steps below:

1. Click **Setup** on the Live View screen and log in as Administrator if prompted.
2. Click The **Administration** tab.
3. Click **Program Management (ETC)** and enter the Administrator password when prompted.
4. Click Show (to the right of The agent program for DDNS).
5. Select the **Enable DDNS** check box.
6. Enter the **ID**, **Password**, and **Hostname** specified on the DDNS document shipped with your DVR.

Note Ensure the DVR has an IP address by setting it statically. The Network settings may need to be changed. If you are not sure of the correct values, contact the individual or department responsible for network administration at the site.

Set the IP Address

To set the IP address of the recorder, follow the steps below:

7. On the Live View screen, click **Exit** and choose **Restart in Windows Mode**.
8. On the desktop, right-click **Network** and click **Properties**.
9. In the **Network and Sharing Center**, click **Local Area Connection**.
10. Click **Internet Protocol (TCP/IP)** and then click **Properties**.
11. Select **Use the following IP address**.
12. Enter the following values (or as specified by the department responsible for network administration).
 - a. **IP Address**: The first three sets of numbers should match the router's local IP address and the last set should be a unique number between 1-254.
 - b. **Subnet Mask**: This should match the router's setting (commonly 255.255.255.0 for 192.X addresses and 255.0.0.0 for 10.X addresses).
 - c. **Default Gateway**: This is the router's internal IP address. Once DDNS is configured, the router the DVR connects to will need to be configured to forward ports 80 and 4000 to the IP address of the DVR.

For further instruction on this process, visit

http://www.portforward.com/english/routers/port_forwarding/routerindex.htm

Select the correct model of router, and follow the instructions. Once DDNS and port forwarding have been configured, the recorder will be accessible from any remote site by entering the HOSTNAME into the address bar of Internet Explorer or the IP Address field in the Remote Software.

User Management

The User Management Console allows the administrator to create, edit, and delete user accounts. Each user account can be assigned different privileges to limit the usage of the recorder system. Users can be given administrator privileges by enabling all rights, however only the true administrator account can log into the User Management Console.

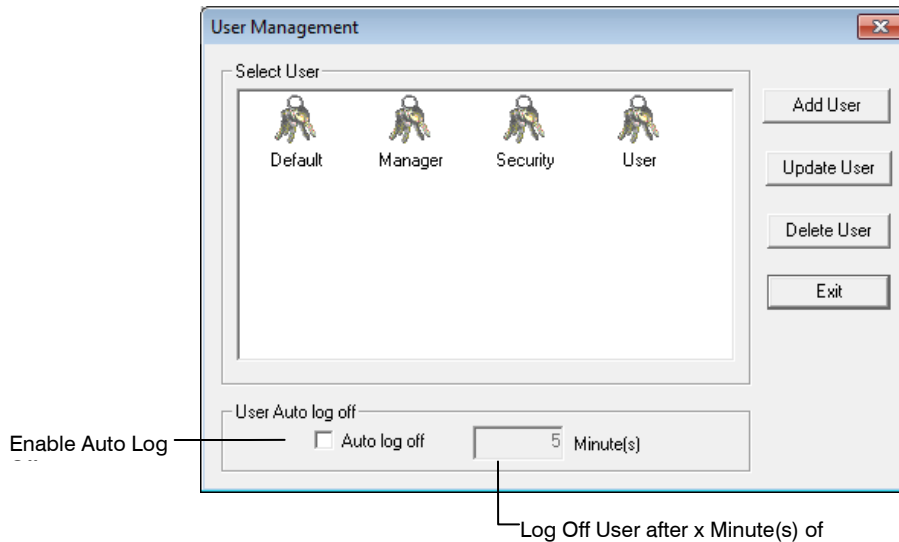

Note The Delete User button immediately deletes the user – use cautiously.

Add a New User

1. From the Live View screen, click the **Administration** tab.
2. Click **User Management**.
3. Click **Add User** to open the **User** window.
4. Enter a **User Name** and **Password**.
5. Enable appropriate **Permissions**.
6. Select **Cameras** and **Audio** channels to hide from the user.
7. Assign a **User Rank**.
8. Click **OK** to save changes and close the window.

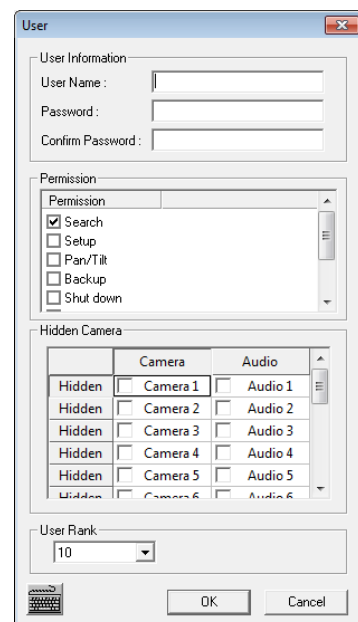

User Rank

The User Ranking structure allows the option to assign a privilege system (1-10 where one has the most rights) to users of the recorder Software. For example. Since only one user is allowed to use the PTZ controls at any one time, an administrator with a higher rank can kick another user out and take control of the PTZ.

The User Rank option affects:

SETUP ACCESS - The recorder Software can only have 1 user accessing Setup at any given time. A user with a higher rank will kick another user out and then open Setup.

NOTE: User settings will NOT be saved when a user with a higher ranking logs in.

PTZ CONTROL - The recorder SOFTWARE can only have 1 user using the PTZ controls at any given time. A user with a higher rank will kick another user out and then open the PTZ controls.

1. From the Live View screen, click **Setup**.
2. Click the **Administration** tab.
3. Click **User Management**.
4. Enter the Administrator **password** and click **OK**.
5. Select a user from the **Select User** box and click **Update User**.
6. Set the user's rank using the **User Rank** list and click **OK** to save changes.

Changing the Administrator Password

1. Inside the **Administration** tab, click **User Management**. When the prompt appears, click **Change Password**.
2. Enter the new **password** and click **OK**.

Default Administrator Password

The default administrator login is:

User: Administrator

Password: <blank>

Log Management

The **Log Management** window provides the user the options to overwrite log files or schedule log deletion.

Set up Log Management Options

1. From the **Administration** tab, click **Log Management**.

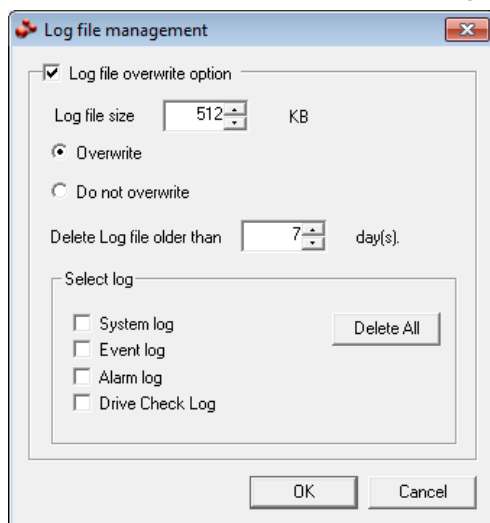

2. Select the check box to enable the **Log File Overwrite Option**.

Set Log Overwrite

- a) Select **Overwrite** and define the size of the log file cache.

Set Log Cache Size

- a) Select **Do Not Overwrite** and define the number of days to maintain log files.

Manually Delete Log Files

- a) Select the type(s) of log file to delete. **System Log, Event Log, Alarm Log.**
- b) Click **Delete All**.

3. Click **OK** to save the settings and close the window.

Status Check / Email

General

1. Click **Setup** on the Live View screen.
2. Click the **Administration** tab.
3. Click **Status Check/Email**.
4. Select the **Enable Email Alarm** check box.
5. Enter a **From Name** and e-mail **Address**.

Note This name and address will appear in the From line of the email alert message.

6. Enter the SMTP information for the “From” email account. Contact the email administrator for this information if necessary.
7. If using a secondary e-mail account select the **Use Secondary SMTP** check box and complete the SMTP information.
8. Click **Test** to check settings.
9. Click **Apply** when finished.

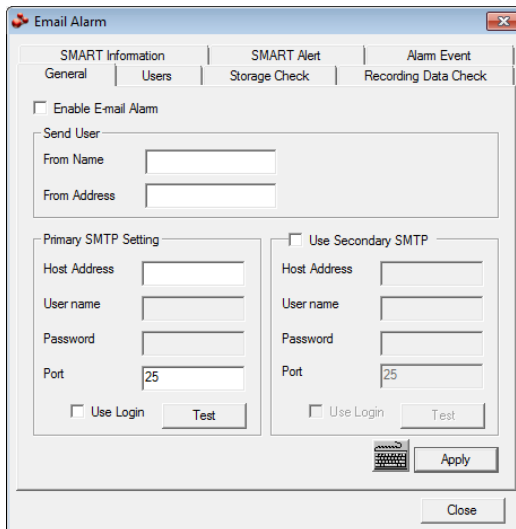

Users

1. Set up the **General** tab first.
2. Click the **Users** tab.
3. Select the type of **Event** to send email on.
4. Enter the **User Name** and **E-mail Address** of an email recipient.
5. Click **Add**.
6. Repeat for additional recipients and types of events.

Note A separate email notification for each type of event must be set up for a single recipient to receive notifications for each type of event.

7. Click **Apply** when finished.

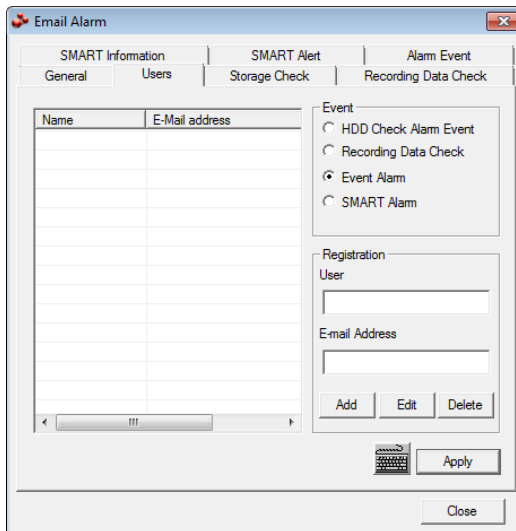

Storage Check

1. Set up the **General** and **Users** tabs first. (see previous sections)
2. Select the **Use Storage Check** check box.
3. Define the number of minutes.
4. Select an **Alert Option**, **Beep** or **Popup Message**, if desired.
5. Click **Apply**.

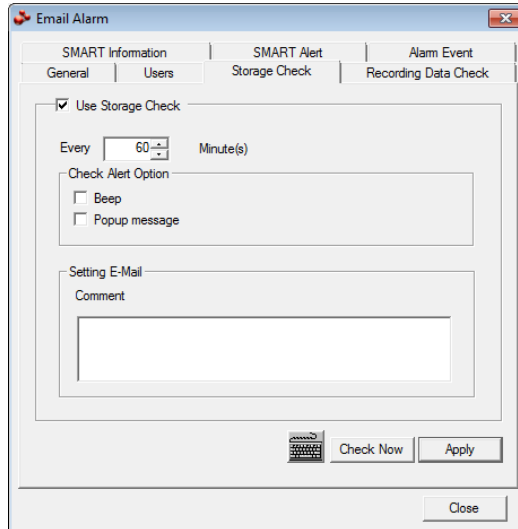

Recording Data Check

1. Set up the **General** and **Users** tabs first. (see previous sections)
2. Select the **Recording Data Check** check box.
3. Define the number of hours between data checks.
4. Select the **Action Method**.
5. Click **Apply**.

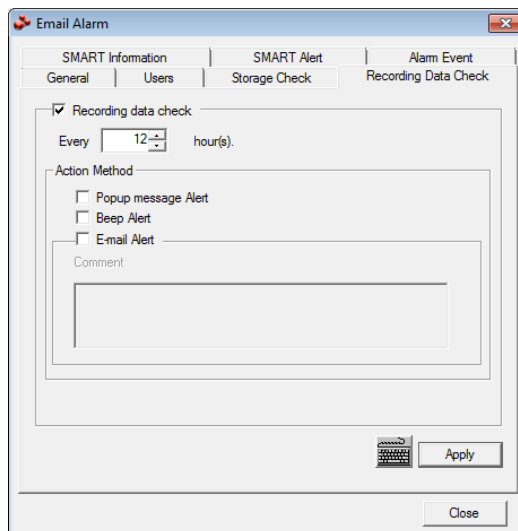

SMART Information

The SMART Information tab displays Hard Drive information.

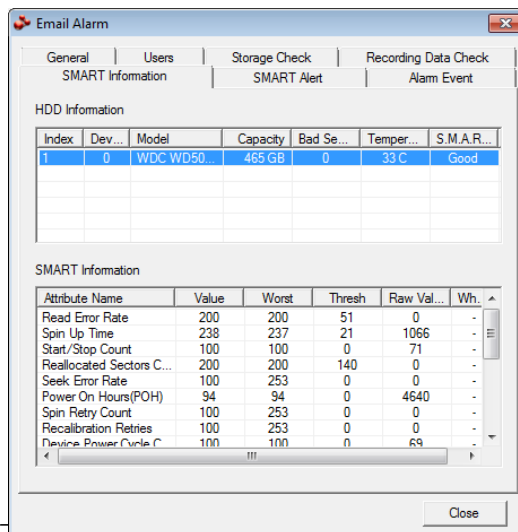

SMART Alert

1. Set up the **General** and **Users** tabs first. (see previous sections)
2. Select the **Enable SMART Alarm** check box.
3. Define the number hours between SMART checks.
4. Select the type of SMART event to trigger an action.
5. Define the maximum HDD temperature.
6. Select an action method.
7. Click **Apply**.

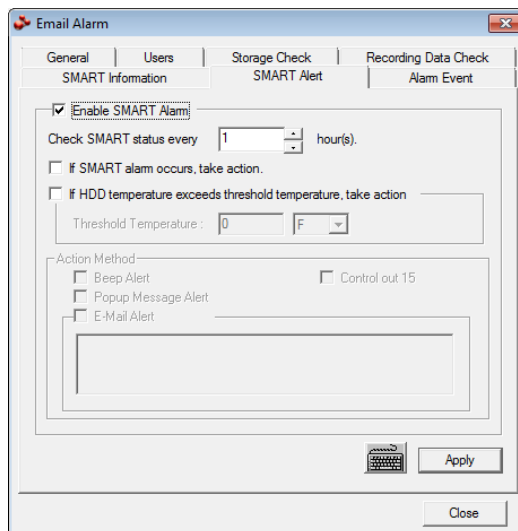

Alarm Event

1. Set up the **General** and **Users** tabs first. (see previous sections)
2. Select the **Use Email Alarm** check box.
3. Define the number of minutes between recording data checks.
4. Select **Motion** and/or **Sensor** to send and alert on that type of event.
5. Click **Apply**.
6. Click **Close** to return to the **Administration** tab.

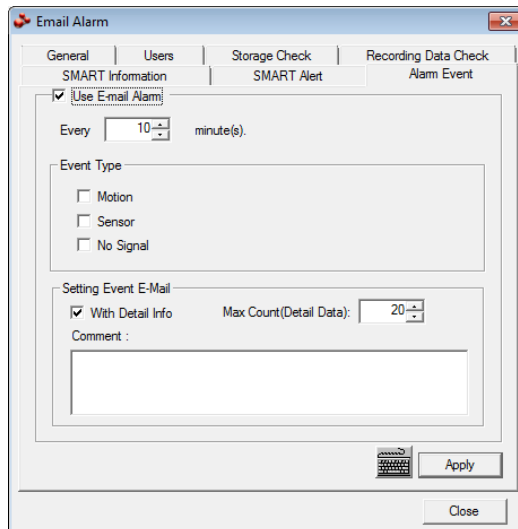

Data Management

Data Management is available for select regions where operators must delete data after a set number of days. If you need to purge your video data, and this feature is not enabled on your Fusion recorder, contact Technical Support.

Information

The Information display allows users to define the site code necessary for connecting to remote software, save comments relative to the recorder and store tech support and contact number information.

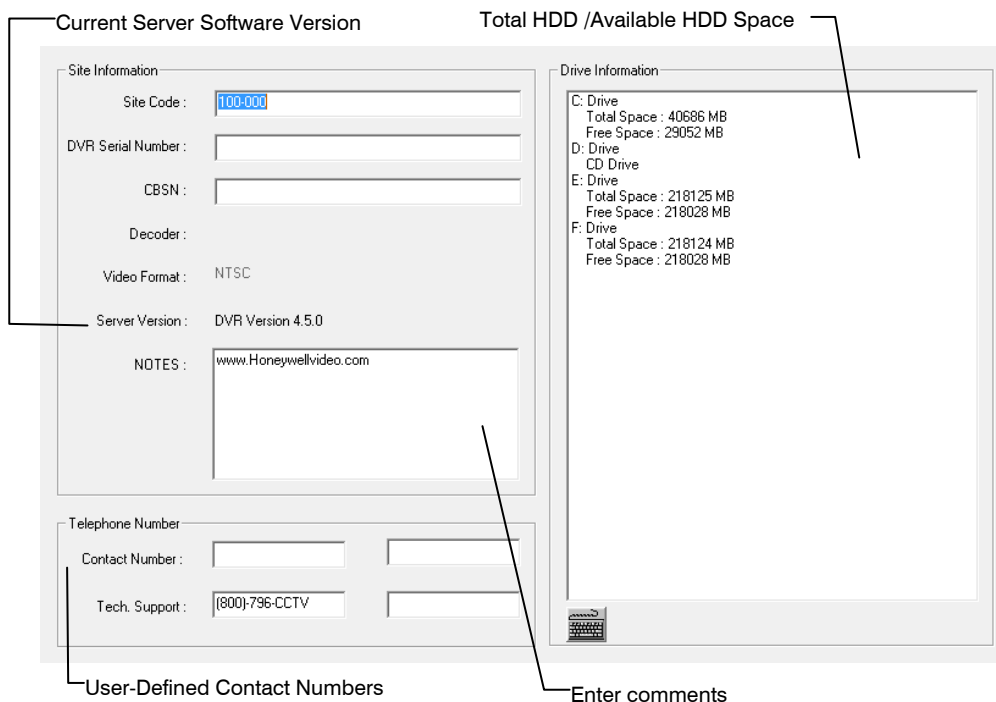

Site Code: A user-specified unique identification name used by other recorder software to identify the recorder. (Remote, Emergency Agent, FVMS, Digital Signature Verifier)

CBSN: Displays the serial number of an internal DVR hardware component.

Instant Recording

The Instant Recording feature allows users to manually initiate recording on a specific camera, overriding the current schedule. When Instant Recording is activated the recorder flags the clip as an event so Instant Recording instances can be found using the Index Search

Instant Recording can be used, for example, when a suspicious object or person is detected and the user wants to flag that section of video for easy retrieval at a later date.

Activate Instant Recording

1. From the Live View screen, double right-click the camera on which to enable instant recording. An INSTANT label will be placed on the upper right corner of the video.
2. To turn the Instant Recording option off, double right-click the camera a second time.

Searching 'Instant Recorded' Video

1. From the Live View screen click **Search**.
2. Click **Index Search**.
3. Select the **Instant Recording** option. See the Search chapter for more information.

Search

Search Overview

The recorder has several options that allow the user to easily search through, and find, a particular section of video. From Motion/Sensor indexing to calendar views highlighting days with recorded video; the recorder is equipped to help the user quickly find a specific video or event.

Note 16 Channel model shown below.

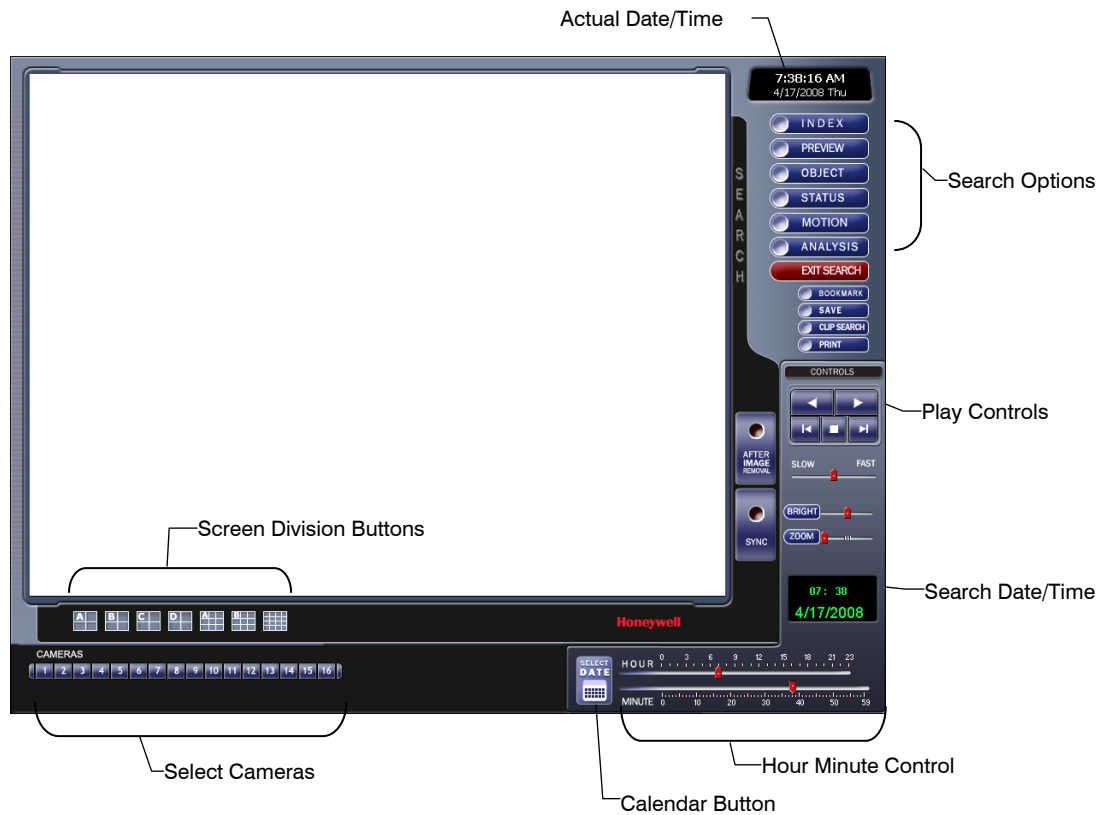

Play Controls

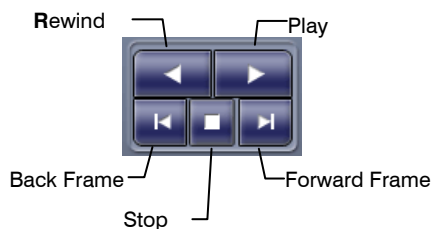

Back Frame	Moves video back one frame.
Rewind	Rewinds video.
Play	Plays video.
Forward Frame	Moves video forward one frame.
Stop	Stops video playback

Hour / Minute Controls

The Hour/Minute Control Bar allows a user to select the Hour and Minute using an easy-to-use slide bar. The user can control the slide bar by clicking and dragging the slider or using the scroll wheel on the mouse.

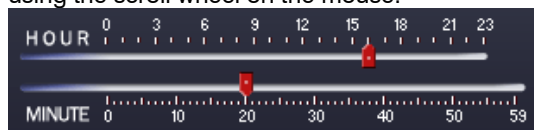

Brightness / Speed / Zoom

The Brightness and Zoom features can get the most out of the images. Adjusting Brightness can brighten up an image to get more detail. Zoom can not only bring the image up full screen but also Zoom into a particular area of the image.

- Slow / Fast:** Increases or decreases playback speed.
- Brightness:** Used to adjust the brightness of an image.
- Zoom:** Used to zoom in on an image.

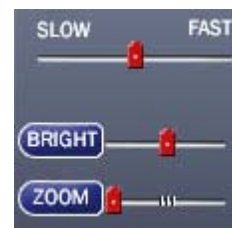

Adjusting the Brightness of an Image

1. Select a single image to adjust by double-clicking on the desired image. Multiple images cannot be adjusted at one time.
2. Move the Bright slide bar to the right or left to adjust the brightness.
3. Reset the brightness by clicking the Bright button.

Zooming in on an Image

1. Select a single image to adjust by double-clicking on the desired image. Multiple images cannot be adjusted at one time.
2. Move the Zoom slide bar to the right or left to zoom in or out of an image.
3. Reset the zoom by clicking the Zoom button.

Zooming in on a Portion of an Image

1. Right-click the area of interest on the image.
2. Repeated right-clicking will zoom in further.
3. Continue to right-click the image and the zoom will cycle back to the original size.

Adjust the Brightness of an Image

1. Select an image to adjust by double-clicking on the desired image. Multiple images cannot be adjusted at one time.
2. Move the **Brightness** slide bar to the right or left to adjust the brightness.
3. Reset the Brightness by moving the slider back to the center of the bar.

Zooming in on an Image

1. Select an image to adjust by double-clicking on the desired image. Multiple images cannot be adjusted at one time.
2. Move the **Zoom** slide bar to the right or left to zoom in or out of an image.
3. Reset the Zoom by moving the slider back to its original position on the bar.

Zooming in on a Portion of an Image

1. Right-click the area of interest on the image and select **Zoom**.
- or - Double-right-click the image.
2. Repeat to zoom in further.
3. Continue clicking the right mouse button and the image zoom will cycle back to the original size.

Open Video from a Saved Location

Previously saved video clips or backup files can be searched for content. Find file by date and time or by name.

1. Click **Open** to search for the saved file.
2. Select a file from the list of saved clips and backup files or search by start hour.
3. Click **OK** to open the saved file.

Time Sync

The Time Sync option synchronizes a single channel of video to playback in real time. Ordinarily the video may playback slower or faster depending on several factors, including how many IPS recorded and number of cameras playing at the same time.

1. Select a single image to synchronize by double-clicking on an image.
2. Click **Time Sync**. The video will now playback in real time.

After Image Removal

The recorder is capable of recording video using one of three different resolutions. When using the 720 x 480 resolution, two fields are mixed. Because of the timing gap between the two fields, according to the standardized image rules, after image might occur to high speed moving images. The Fusion recorder allows the user to remove this by clicking the **After Image Removal** button.

Performing a Basic Search

There are several different types of searches that can be performed on the recorder. The most basic involves selecting the date, time, camera, and clicking play.

1. Click the Calendar button to select a date.
2. Select a time by clicking the up and down arrows to the right of the time display.
3. Click **OK**.
4. Select one or more cameras.
5. Click Play. Video can be played forwards, backwards, or frame-by-frame.

Printing an Image

1. Using the Search screen, locate a frame to print.

Note Only one camera can be selected at a time for this function to work.

2. Click **Print**. A **Print Options** window appears. Depending on the printer being used, there may be several printing options available. Refer to the printer manual for more information.
3. Click **Print** to print the selected images.

Note The message "NO DEFAULT PRINTERS INSTALLED" will display if no printer is installed.

Daylight Saving Time

The recorder automatically adjusts for Daylight Saving Time changes. When the hour “jumps forward” no video is lost because an hour is skipped. However when the hour “falls back” there is a duplicated hour that under normal circumstances would be recorded over. The Fusion recorder actually records both hours and allows the user to select which hour to play if the need arises.

To access the ‘lost hour’:

1. From the Search screen, click the Calendar button.
2. Select the date when Daylight Saving time ‘lost’ an hour. The **Daylight Saving** option appears.
3. To play back the ‘lost hour’, select the **Daylight Saving** check box and enter the repeated hour in the time box.
4. Click **OK** to confirm the date and begin playing the video using standard search features.

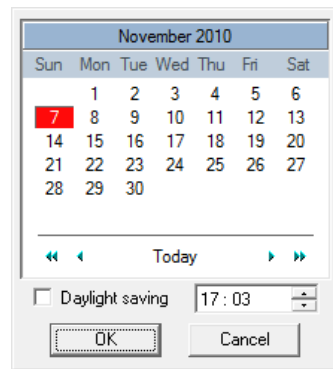

Save to JPG or AVI

The recorder can export single images in a JPG Image file format and save video clips in an AVI format. Both JPG and AVI file formats are the most commonly used graphical formats today. Virtually every computer offers some type of support for these file formats which make them the most ideal formats to use.

JPG

Optimized for compressing full-color or grayscale photographic images, JPG images are 24-bit (16.7 million color) graphics. Use JPG to export a single image or frame.

AVI

AVI image data can be stored uncompressed, but it is typically compressed using a Windows-supplied or third party compression and decompression module called a codec. AVI is used to export a video clip.

To save a .jpg still or .avi video clip:

1. From the **Search** screen, click **Save**.
2. Select the **Export Type: Image File** (JPG) or **AVI File**.

Note Different image format types provide different file-sizes, quality and compatibility.

Image File

- a) Select **Quality (50 > 100)**. When size is not an issue, set the quality to 100.

AVI File

- a) Enter the **duration** (seconds) to record. Although 100 is the longest time displayed, a longer recording may be entered manually.
 - b) Select a **Compression Codec**. Each codec provides different levels of quality, compatibility and file-size.
 - c) Select **Quality - 50 > 100**. When size is not an issue, set quality to 100.
3. Click **Export** to save file. The **Cancel** button exits the window without exporting file.

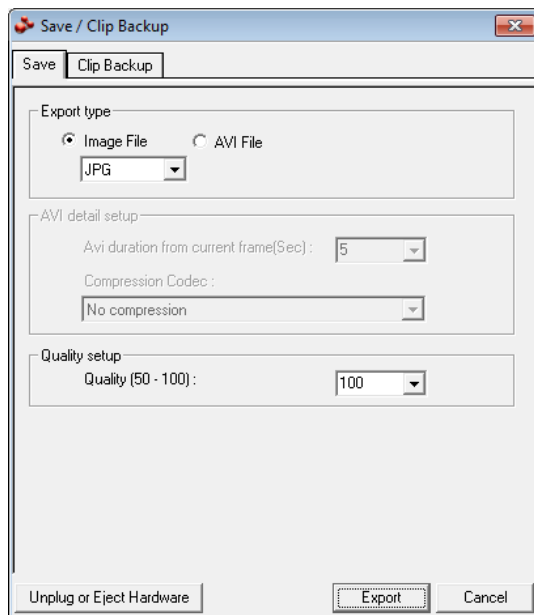

Bookmarks

Use bookmarks to mark a video clip during a search. Export bookmarked data using the Clip Backup feature.

1. Perform a search for the desired video.
2. Stop playback at the beginning of the desired clip.
3. Right-click the video and select **Start Bookmark**.
4. Click the play button to continue playback.
5. Stop playback at the end of the desired clip.
6. Right-click the video at the desired end point and select **End Bookmark**.
7. Type a name to identify the bookmark in the Title box.
8. Enter a memo or notes in the **More Information** box.
9. You may also select additional channels to include video at different locations recorded at the same time.
10. Click **Create**.

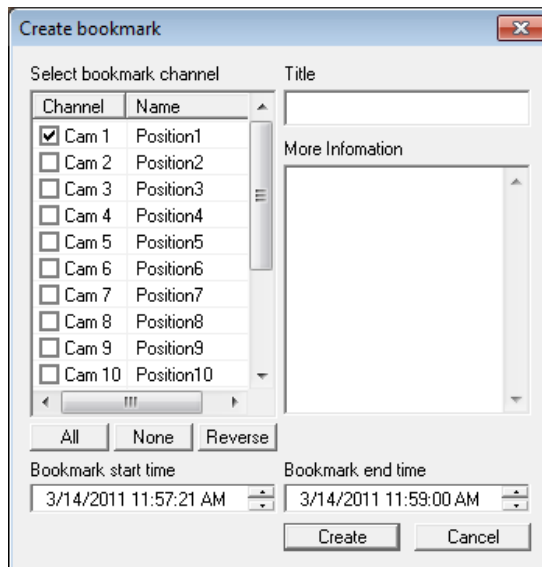

Modify Bookmarks

You can modify a previously created bookmark to change the start or end time of the clip, add additional comments, change the title, or add additional cameras.

1. From the **Search** screen, click **Graphic Search** and then click **Bookmark**.
2. On the calendar, select the date the desired bookmarks were created.
3. Select the desired bookmark from the list.
4. Make the desired change.
5. Click **Modify**.
6. When the modification is complete, click **Cancel** to close the window.

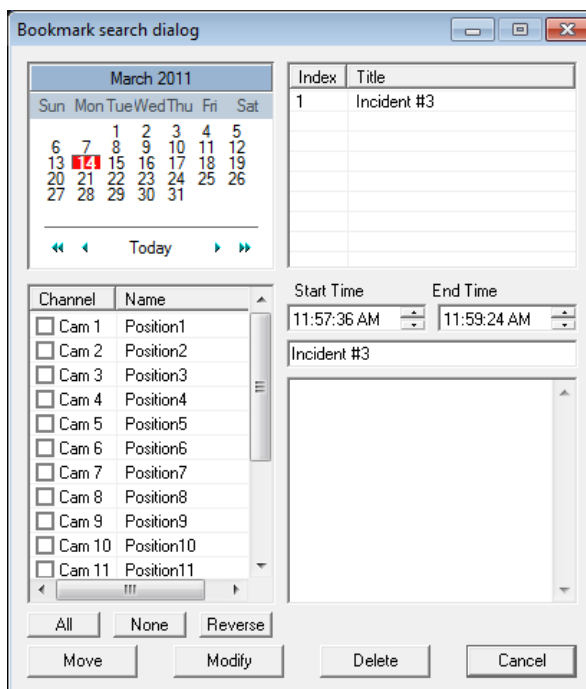

Single Clip Backup

Along with the Save option, a single camera backup option is also included with the Fusion software. The single Camera or Clip Backup allows the user to backup a single camera without having to backup multiple cameras at a given time. The Clip Backup option gives the users the ability to choose a backup time frame, choose a specific camera, add memos, and even make a copy for the Backup Viewer if needed.

1. From the **Search** screen, click **Save**.
2. Select the drive from the file tree to save data to. (Hard disk drive, removable drive (USB), CD/DVD drive)
3. Select cameras from the list.
4. Define the **Start** and **End** time of the backup clip.
5. Select the **Include Viewer** check box to include a copy of the proprietary Backup Viewer Software to view the clip on virtually any Windows machine.
6. Click **Add Memo** to include additional information.
7. Click **Backup** to start the backup.

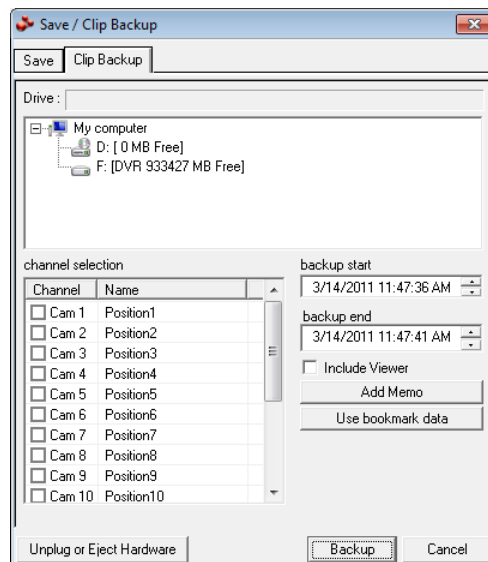

Note If backing up to a removable USB device click the Unplug or Eject Hardware button after backup is complete to safely remove the device.

Single Clip Backup Using Bookmark Data

1. From the **Search** screen, click the **Save** button.
2. Select the drive from the file tree to save data to. (Hard disk drive, removable drive, CD/DVD drive).
3. Click **Use Bookmark Data**.
4. On the calendar, select the date the desired bookmarks were created.
5. Select the desired bookmark from the list.

Note To include multiple bookmarks in a clip backup, select the Multi Backup check box before selecting the desired bookmarks.

6. Type notes in the **Memo** box to include additional information.
7. Click **OK** close the **Bookmark data** window.
8. Click **Backup** to start the backup.

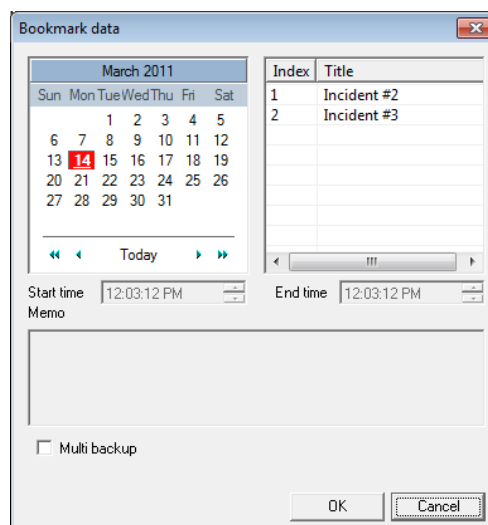

Note If backing up to a removable USB device click the Unplug or Eject Hardware button after backup is complete to safely remove the device.

Index Search

Using the Index Search can greatly decrease the amount of time spent searching through saved video. The Index Search allows a user to perform a search based on criteria such as Sensor, Motion and Instant Record events

Performing an Index Search

1. Click the Calendar button on the **Search** screen to select the date to search.
2. Click **Index Search**.
3. Select the cameras and sensors to include in the search.
4. Select the **Select Time** check box to define a specific period.
5. Select an event type to search (**Sensor**, **Motion**, **Instant Record**) or select the **All Event** option.
6. Click **OK**. There may be a delay while results are returned. Results will be displayed in a column on the left side of the screen – Each line represents a segment of video. If no results are found, “NO IMAGE FOUND” will appear in the column.
7. Once the results are displayed, double-click any one to play the associated video.
8. Once the desired image is found, apply it to the Main Search by clicking the **Close** button at the bottom of the results column.

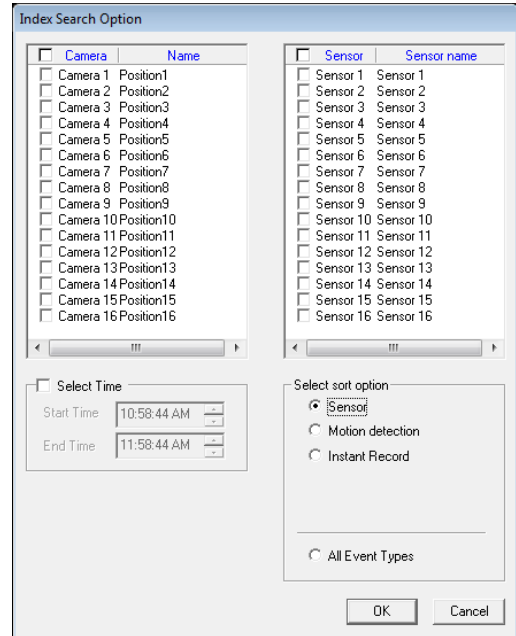

Index Search Results Display

Image Display Area

Event Recorded on Camera #

Time Event Occurred

Event Type:
M – Motion
S – Sensor
IR – Instant Record

Time	Camera	Type
08:34:21	C01[Back R	M
08:35:34	C01[Back R	M
08:36:17	C01[Back R	M
08:36:38	C01[Back R	M
08:37:17	C01[Back R	M
08:38:49	C01[Back R	M
08:39:31	C01[Back R	M
08:40:31	C01[Back R	M
08:42:12	C01[Back R	M

Preview Search

Preview Search can be used in a number of circumstances to quickly find an exact moment where an event, such as a theft, occurred. The Preview Search gives a 24 Hour visual overview of a single camera by separating a 24 hour period (1 day) into 24 images, one image for each hour of the day. The search can then be further narrowed down into ten minute increments and one minute increments by selecting one of the images displayed.

These example images show how the Preview Search functions.

The first screen that appears has 24 images displayed. Each image represents the first second of each hour. If there is no image recorded during that period then nothing will be displayed.

When an hour is selected (by double-clicking on the image), a new screen appears with 6 images. Each of these images represents a 10 minute segment of video within the selected hour.

Once a 10 minute segment is selected (by double-clicking on the image) the final screen appears which breaks down that 10 minute segment into 1 minute increments (10 images).

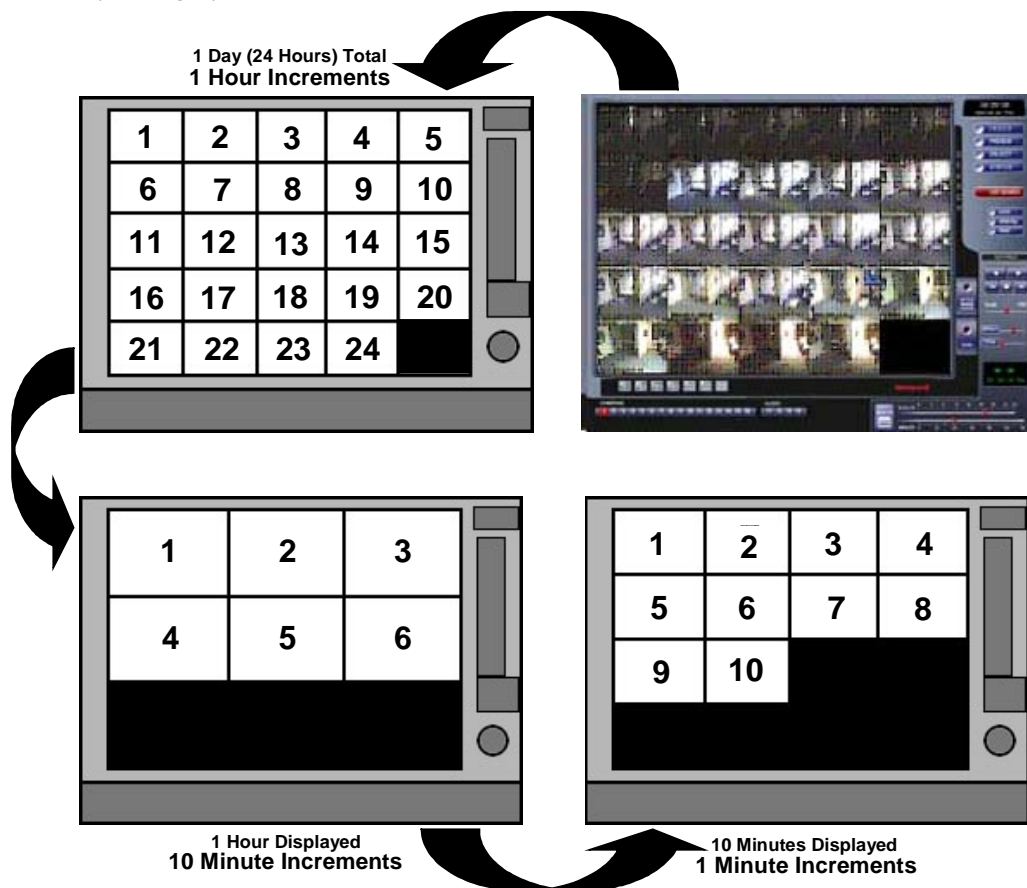

Performing a Preview Search

1. Select a single camera by either turning off all cameras but one or double-clicking a displayed image.
2. Click **Preview Search**. 24 images display. If there is no recorded video during a portion of the day, "No Image" will be displayed where the image should be.
3. Refine the search by double-clicking on an image to select it. 6 images display. If needed, return to the previous 24-image view by right-clicking on an image.
4. Refine the search by double-clicking on an image to select it. 10 images display. If needed, return to the previous 6-image view by right-clicking on an image.
5. Double-click an image to select the 1-minute segment of video to play. A single image displays. If needed, return to the previous 10-image view by right-clicking on an image.
6. Use the Play controls to play the video of the selected segment.
7. To exit out of the **Preview** search with the current image still selected, click **Preview Search** again to clear it.

Object Search

Object Search is a powerful search utility that is used to search a region on the video for any motion changes. Results are neatly displayed and can be viewed quickly.

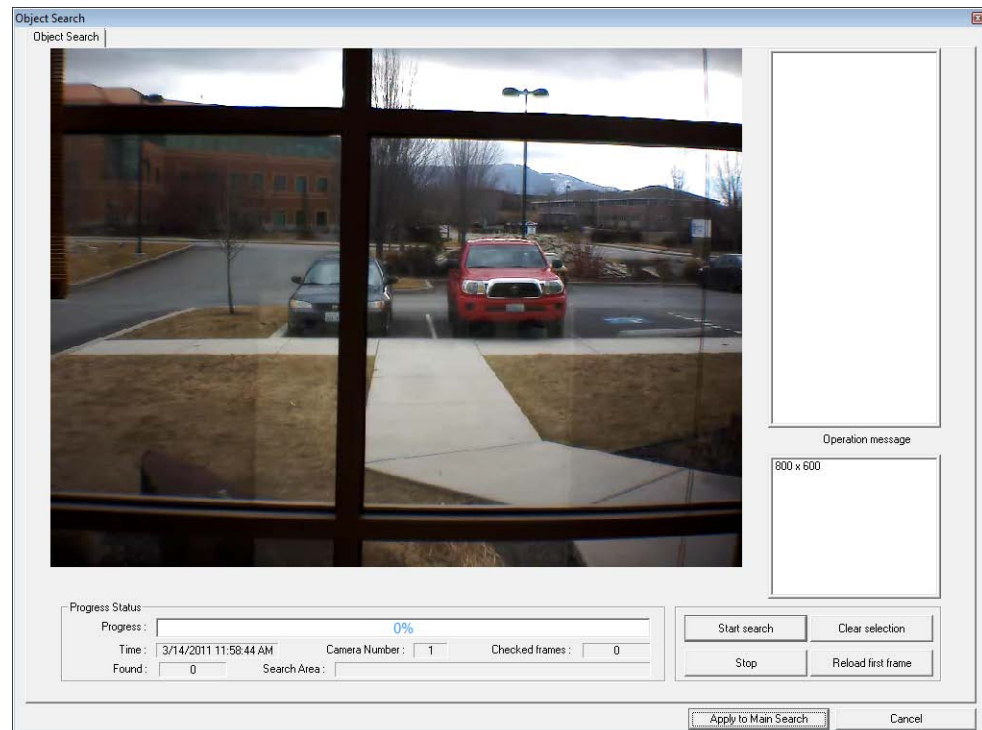

Performing an Object Search

1. Perform a Basic Search. See the instructions on Performing a Basic Search.
2. Select a single camera, either by turning off all cameras but one or by double-clicking a displayed image.
3. Click **Object Search** on the **Search** screen.
4. Click and drag the mouse on the video display to define a motion region area. Resize by pulling on the small square boxes located on the outer perimeter of the area.
5. Click **Start Search**, the **Object Search Filter Information** window will open
6. Select an **End** date/time. One hour is the default setting.
7. Adjust the sensitivity if necessary.
8. Click **OK**.
9. Select a motion event from the search results list displayed on the right
10. Click **Apply to Main Search** to display the selected image in the main **Search** screen and to use play controls
11. To start a new object search using the original image, click **Reload First Frame**.
12. To exit **Object Search** without selecting an image, click **Cancel**.

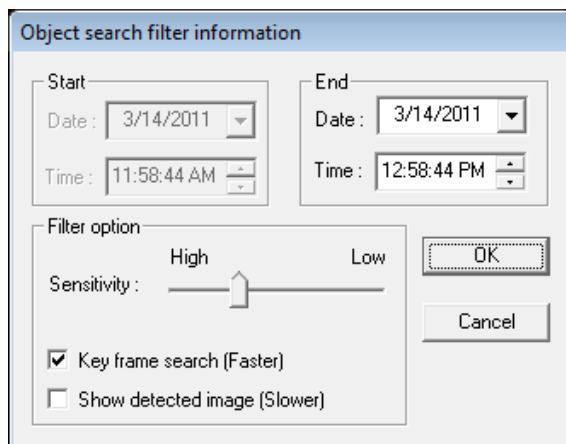

Status Search

The Status Search option displays video in graph format. (16 Channel Model Show)

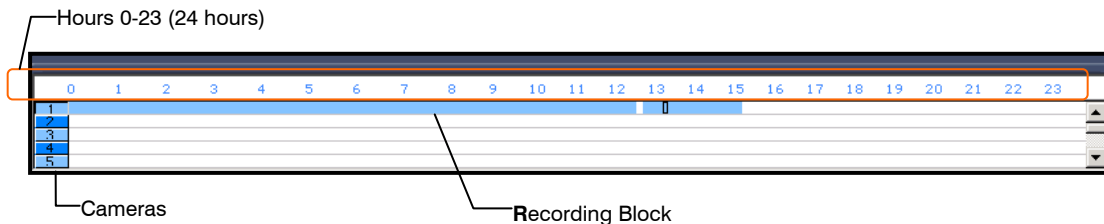
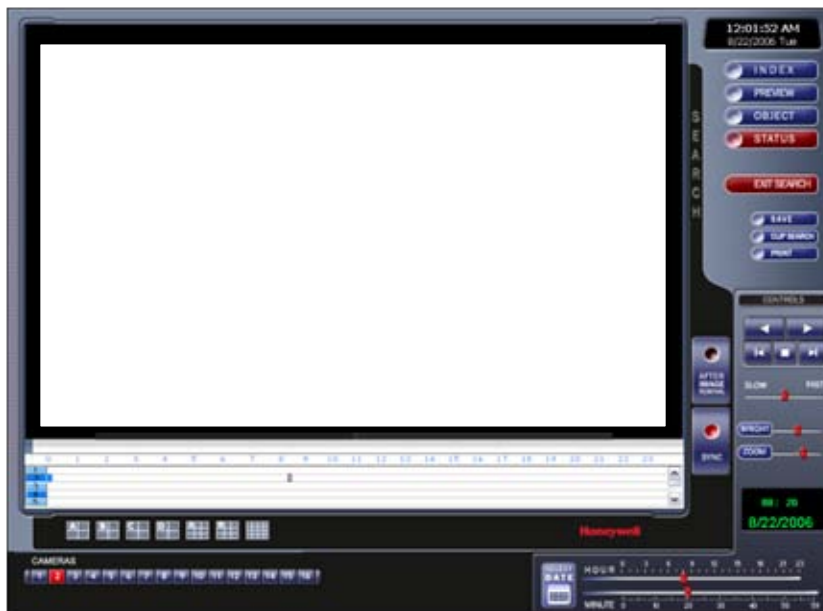

Performing a Status Search

1. Click **Status** on Search Screen Display.
2. Click the calendar icon to select a day.
3. Click on an area of the blue recording block. Only one camera can be displayed at a time.
4. Recorded video from the corresponding camera and time block will display above.
5. Use the mouse or arrow buttons to move through recording blocks and view video.

Motion Search

The Motion Search provides a dynamic display of the levels of motion in recorded video. Adjust the level of motion to only play clips of video at or above that level.

Tip To enable motion data to be saved for Motion search, ensure that you select the following settings:
On the **Motion** setup page under **Motion Regions**, select the **Detect Detail Motion Area** check box.
On the **General** setup page under **Display**, select the **Motion Detect on Continuous Recording** check box.

Note Motion Search is only available for newly recorded video; it is not compatible with video recorded prior to version 3.6.

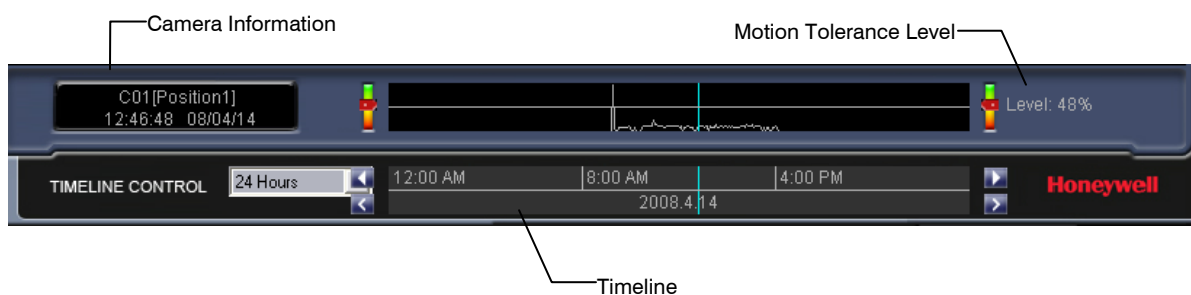

Performing a Motion Search

1. From the **Search** screen select a camera. Motion Search can only be performed on one camera at a time.
2. Click **Graphic Search** and then click **Motion Search**.
3. Click the calendar icon to select a day.
4. Adjust the motion level line.
5. Adjust the timeline display settings.
6. Click the play button to start playback.

Tip You can drag the blue line on the Timeline or motion level box to adjust the time.

Audio Playback

Audio is played back at 48,000Hz.

To play audio with the video:

1. Select a single camera by turning off all cameras but one using the Camera Select buttons. The audio buttons will be displayed.
2. Select a single audio channel to play. When an audio channel is selected, the Time Sync button will be automatically selected.
3. Click Play.

Tip When connecting speakers to the recorder for the first time, exit the Fusion software to Windows mode before plugging in the speakers. This will ensure that the speakers are detected properly.

Pan / Tilt / Zoom

Pan / Tilt / Zoom Overview

The PTZ controls within the recorder allow for powerful control over the cameras. This can be extremely beneficial by increasing the usefulness of the recorded video. Using the PTZ controls you can create custom preset configurations that can continuously sweep across large areas.

Note PTZ setup and control is only available for supported video encoders with a PTZ RS-485 pass-through.

Enable the PTZ Settings

1. Inside the recorder PTZ Setup, select the PTZ camera using the Camera Channel list.
2. Enable the PTZ functions of the camera by selecting the **Enable Pan/Tilt** check box.
3. Select the appropriate **Protocol** and set the **PTZ Driver Address** and **Serial Port Settings** (See Advanced PTZ Setup in this chapter).

Note The majority of major PTZ manufacture protocols are included in this software. Refer to the Supported Protocols list in this manual.

4. Click **Apply** and then click **Exit**.
5. From the Live View screen, click **PTZ** (See the chapter on DVR Basics). The PTZ Controller will open.
6. Select the PTZ camera to control by clicking on its video on the Live View screen. The camera number will appear inside the PTZ controls.
7. Using the PTZ controls, move the PTZ around.

Advanced PTZ Setup

Note Preset and Tour options may vary depending on the camera

Creating and Viewing Preset Positions

A Preset Position is a user-defined location where the camera can be pointed, zoomed in, and focused. Preset positions can be defined and labeled if the camera supports this.

Creating a Preset

1. Inside Setup, click the **PTZ** tab and select a camera from the **Channel** list.
2. Select the **Pan/Tilt Connection** check box and select the appropriate PTZ protocol.
3. Under **PTZ Status on Close**, click **Controller** to open the PTZ graphical gontroller.
4. In the **Preset** box, select a Preset from the list to modify (a red box will appear around the Preset).

5. Use the controls on the Graphical Controller to move the selected camera to the desired position.

6. Enter a Dwell Time and Speed Setting. This is used for the Tour 2 function (Each preset can have a different Dwell and Speed setting).
7. Click **Set** once the camera is in the desired position.
8. Enter a name in the new window and click **OK**.

Note Preset positions can also be created using the advanced buttons on the PTZ graphical controller.

Viewing a Preset

1. From the Live View screen select the PTZ camera by clicking on it.
2. Using the keyboard click the number keys corresponding with the Preset Positions. The camera will move to the saved Preset.
3. Presets can also be activated using the on-screen PTZ controller. Open the controller and click a preset number button.

Understanding Tours

The following section explains PTZ Tour options. Not every Tour method will be available for each PTZ camera.

Preset Tour

Cycles through the selected Recorded Presets.

Preset Tour 2

Cycles through the selected Recorded Presets with the addition of a definable Travel Speed and Dwell Time.

Mimic Tour

'Mimics' a user-defined motion path, copying everything the user does (including speed).

Privacy Zone

A user-defined masked out area so it cannot be viewed.

Sequence

Displays a list of preset sequences.

This list is only displayed on supported protocols.

Travel Speed

Sets the speed at which a PTZ moves from one Preset position to the next (when using Preset Tour 1).

Dwell Time

Defines the length of time (in seconds) that a PTZ Tour stays on a Preset Position (when using Preset Tour 1).

The **Honeywell VCL** Tour has been updated. Preset 1 now obeys configured speed and dwell times and Preset 2 uses PTZ dome defaults.

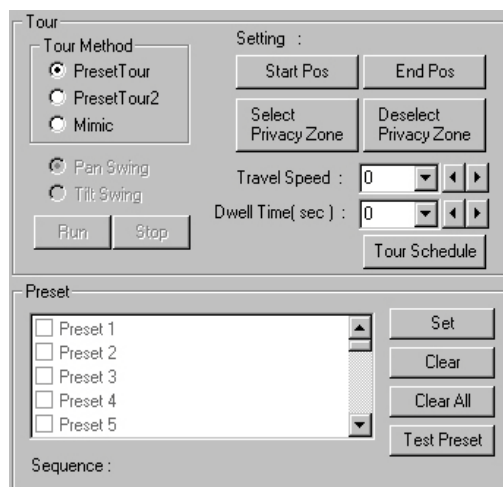

Creating a Preset Tour

1. Select two or more Preset Positions. See Creating a Preset above.
2. Select the Preset Tour method.
3. Define a Travel Speed and Dwell Time for the tour.
4. Click the Apply button.

Viewing the Preset Tour

1. On the Main Display screen, click the PTZ button to open the graphical controller.
2. Click the video display of the desired PTZ camera.
3. Click the Tour button. The Preset Tour will activate.

Creating a Preset Tour2

1. Select two or more Preset Positions. See Creating a Preset above.
2. Select the Preset Tour2 method.
3. Click the Apply button.

Viewing the Preset Tour2

1. On the Main Display Screen click the PTZ button to open the graphical controller.
2. Click the video display of the desired PTZ camera.
3. Click the Tour button. The Preset Tour2 will activate.

Creating a Mimic Tour

1. Select the Mimic Tour Type.
2. Click the Controller button to open the PTZ graphical controller.
3. Click the Start Position button.
4. Using the PTZ Controller, move the PTZ in the path of the tour to mimic.
5. Click the Stop Position button when finished moving the PTZ around.
6. Click OK or Apply to save.

Viewing the Mimic Tour

1. On the Main Display Screen click the PTZ button to open the graphical controller.
2. Click the video display of the desired PTZ camera.
3. Click the Tour button. The Mimic Tour will activate.

PTZ Status on Close

The PTZ Status on Close option defines the default settings for a PTZ camera when the controller is not open. This includes activating a tour, moving to a preset position or leaving the camera as it.

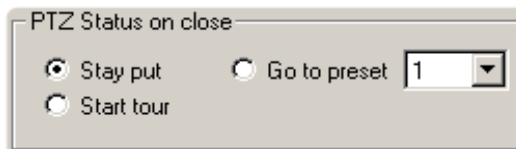

Stay Put

Leaves the PTZ in its present state.

Start Tour

Starts the Pre-Defined Tour function when the PTZ controller is closed.

Go To Preset

Moves to a Selected Preset position when the PTZ controller is closed.

Activating the PTZ Status on Close Option

1. Start by creating a Preset or Tour for the selected camera. See the instructions above.
2. Select either Start Tour or Go To Preset.
3. Click Apply to save.

PTZ Tour Scheduling

The PTZ Tour Scheduling option allows users to create set tour schedules for PTZ cameras connected to the DVR. The Tour Schedule allows users to schedule tours on specific days of the week and specific hours of the day for multiple PTZ cameras. Selected time frames are designated in blue and non-selected (default frames) and shown in white.

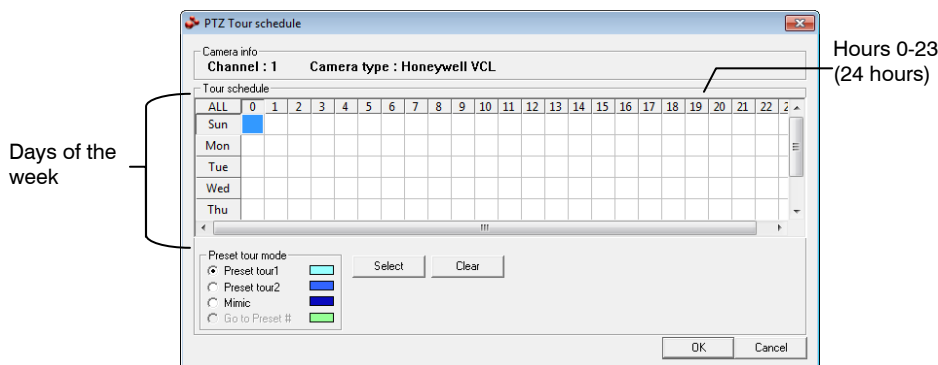

Create PTZ Tour Schedule

1. Click **Setup** on the Live View screen.
2. Click **PTZ**.
3. Select the desired PTZ camera channel from the **Channel** list.
4. Click **Tour Schedule** to open the **PTZ Tour Schedule** window.
5. Click and drag the mouse cursor to select blocks of time (hours 0-24) on the desired days of the week, and then click **Select**.

PTZ Address Setting

Some protocols support software address settings.

Address Setting

RX Address 1 : Previous ID : Set ID

RX Address 2 : New ID : PT Driver Address :

The **RX Addresses** and **ID settings** are compatible with a particular line of receivers that support 2 ID addresses

The **PT Driver Address** is associated with the PTZ ID address set on the camera. The addresses must match for the DVR to communicate with the proper PTZ camera. This is especially important when a large number of PTZ cameras are connected to the DVR.

Note To select a PT Driver Address of 129-254, manually enter the ID in the box.

Accessing PTZ Menus

Some protocols support the ability to access the Internal PTZ Onscreen Menu.

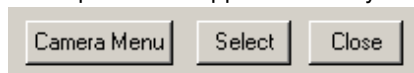

Camera Menu	Opens the PTZ Camera Menu.
Select	Select an item on the onscreen menu.
Close	Close the PTZ Onscreen Menu.
Up/down	The Up and Down buttons on the PTZ controller move through the PTZ menu options.
Left/Right	The Left and Right buttons on the PTZ controller move through the PTZ menu options and/or highlight options.

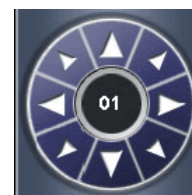

Since every PTZ camera is different, the functions of these options can vary slightly. For an explanation available options, please refer to the operations manual for your camera.

Opening and Editing the Honeywell MAXPRO Menu

1. Click the Camera Menu button. The Camera Menu will appear on the screen.
2. Use the Up and Down buttons on the PTZ controller to scroll through the menu options.
3. Click the Select button to select a menu option. Clicking Select will either scroll one menu deeper or it will change a selected option.
4. Click Close to scroll one menu back, or if at the root menu level, it will close the PTZ Menu.

Controlling a PTZ Camera

Fusion DVRs provide control of PTZ cameras in two different ways.

- Using the Graphical PTZ controller that appears when the PTZ button is clicked on the main screen.
- Clicking on the video itself. This second option is a much more powerful way to control the Camera.

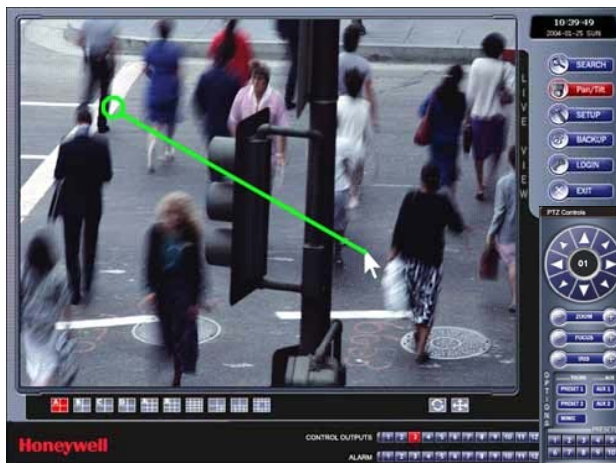

Using the On-Screen Compass

To enable the on-screen compass control:

1. Click **Setup** on the main screen.
2. Click the **PTZ** tab.
3. Select the **On Screen Compass** check box to enable the feature.
4. Click **Apply**.
5. Control the PTZ by dragging the mouse on the screen in the desired direction. A green line will appear to show the direction the PTZ will move. The shorter the line the less the PTZ will move. The longer the line the more the PTZ will travel in the specified direction.

Using the PTZ Controller

- Use the Arrow buttons to control the direction of the PTZ camera.
- To select a new camera, click the video display of a different camera on the Main Screen Display.
-

Note Eight directions are available only for select protocols. Only four of the PTZ Control buttons work for all protocols (UP, DOWN, LEFT, RIGHT).



AUX Buttons

The AUX buttons activate different options for each protocol. The protocols and their options are defined below.

VCL, Javelin (Orbitor), HONEYWELL MAXPRO	AUX 1	Auto Iris
	AUX 2	Auto Focus
Pelco-D, Pelco-P, Kodicom Receiver, CBC, Dennard	AUX 1	Wiper
	AUX 2	Light

Backing up Video Data

Backup Overview

The Backup Center allows you to back up recorded video data from multiple dates and times to one or more locations including the DVD-RW drive, Network Storage Locations, and External Hard Drives.

The recorder can easily backup important video data to an internal or external media location. The most commonly used forms of this are CD-R/RWs, External USB or FireWire Hard Drives, and Network Drives. Every recorder comes equipped with a DVD-RW drive, USB port, and Network Adapter.

The recorder is capable of performing a backup to multiple CD/DVDs when the file sizes exceed the capacity of a single disk. You may also specify multiple locations for backup as well as the order they are recorded to.

The recorder backs up video data using a proprietary compression format that can only be read by the Fusion Backup Program. This ensures the integrity of the data.

Throughout the backup process the recorder will continue recording without interruption. This is the result of the tremendous multiplexing power of the recorder, which allows it to perform virtually all functions without disrupting the recording process.

Nero® Express

The recorder uses Windows® 7® Embedded running Nero® Express 7.0 to write data to the DVD-RW Drive. This solution allows the recorder software to read and write data to the DVD-RW Drive without formatting the disk first.



CAUTION: Although many features are available within Nero, it is highly recommended that you do NOT use any features other than those necessary for the standard backup of video data as outlined in this section, loss of information or software instability may result.

General Screen Overview

The General Backup Screen is used for performing bulk backup of video recorded by all cameras for a selected period, or periods, to a specified storage location.

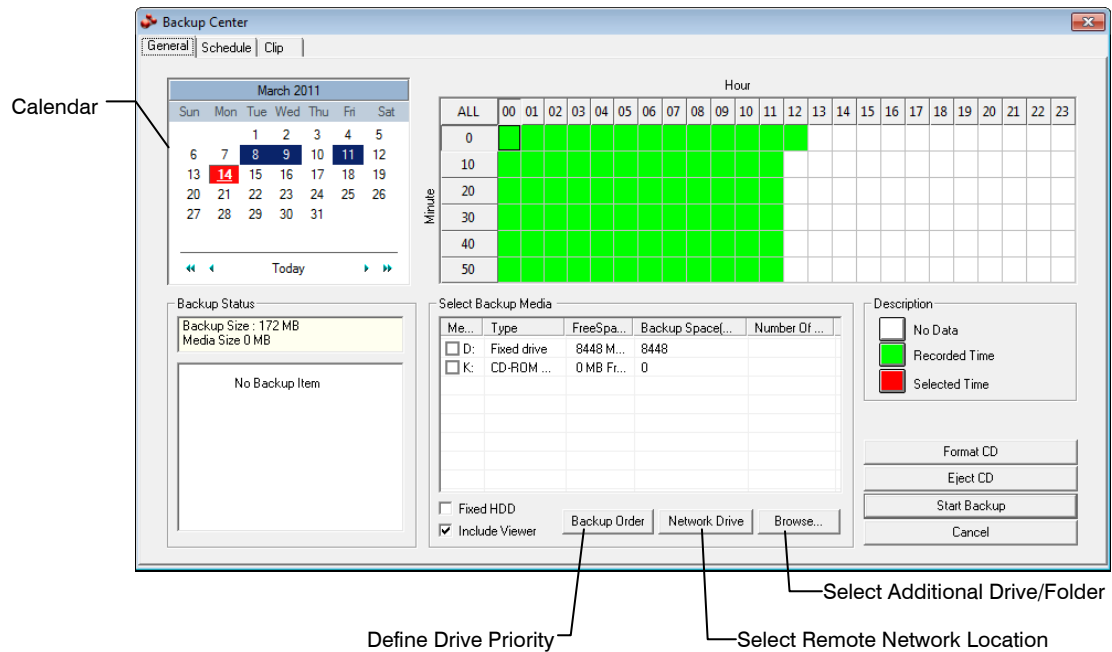

Hour / Minutes

Recording data displays in hourly (24 horizontal columns) and 10-minute (6 vertical cells) segments. Green cells indicate time with recorded video. Red cells indicate time selected for backup.

Backup Status

Displays the size of all video currently selected for backup, the available size of the media currently selected for backup to, and the dates and times of video currently selected for backup.

Fixed HDD

Display all Hard Drives

Performing a General Backup

1. Click **Backup** on the Live View screen.
2. Select the date or dates to back up using the calendar. Dates highlighted in blue contain recorded data.
3. Select the blocks of time to back up using the Hour/Minute grid. Blocks of time with recorded video are highlighted in green. Blocks of time selected for backup are highlighted in red.
4. Select the backup drive or drives under **Select Backup Media**, or click **Network Drive**, or **Browse**. When selecting the CD-RW Drive you must specify the number of CDs to use for backup.
5. Click **Backup Order** to set the backup order.
6. Select the **Include Viewer** check box to include the Backup Viewer Application.
7. Click **Start Backup** to begin the backup process. A progress bar will be displayed in the lower right corner of the Live View screen.

Clip Screen Overview

The Clip Screen is used for backing up video recorded by individual cameras for a selected period of time to a specified storage location

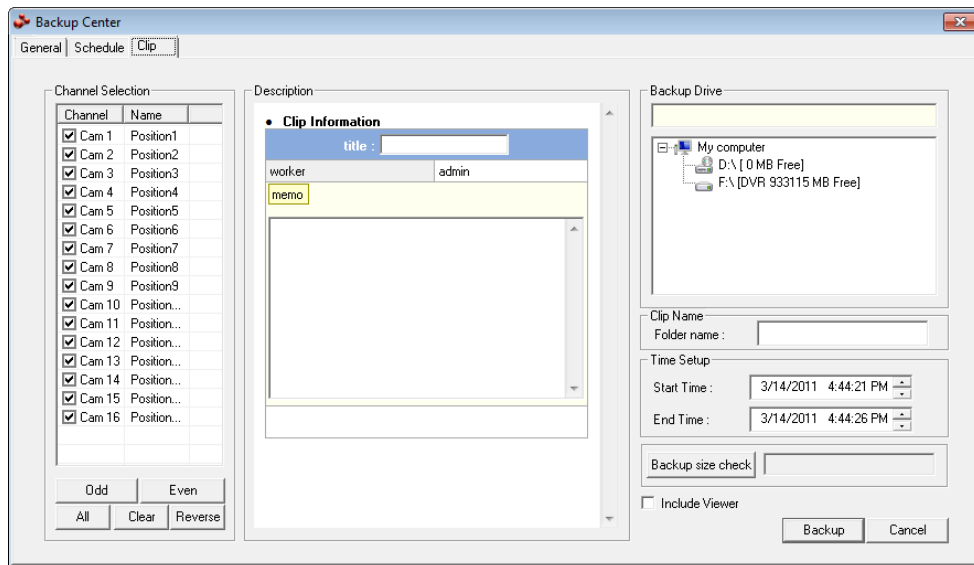

Performing a Clip Backup

1. Click **Backup** on the Live View screen.
2. Click the **Clip** tab at the top of the **Backup Center** window.
3. Set the **Start Time** and **End Time** under **Time Setup**.
4. Select the cameras to back up in the **Channel Selection** box.
5. Select the **Backup Drive** to save the backup video to.
6. Type the **Folder name** for the clip files under **Clip Name**.
7. Select the **Include Viewer** check box to include the Backup Viewer Application.
8. Enter pertinent clip information into the **Clip Information** section in the **Description** box.
9. Click **Backup size check** to confirm the file size of the clip backup.
10. Click **Backup** to begin the backup process. A progress bar will be displayed in the lower right corner of the Live View screen.

Scheduled Screen Overview

The Scheduled Backup Screen is used for performing bulk backup of video recorded by all cameras for a selected period, on a regular scheduled basis (1-24 hours). The Scheduled Backup Screen is similar to the General Backup Screen.

Performing a Scheduled Backup

1. Click **Backup** on the Live View screen.
2. Click the **Schedule** tab at the top of the **Backup Center** window.
3. Select the blocks of time to back up using the Hour/Minute Grid. Blocks of time with recorded video are highlighted in green. Blocks of time selected for backup are highlighted in red.
4. Set the **Backup Time** to perform the backup.
5. Set the **Repeat Backup(Daily)** time to specify the number of hours between backup procedures (between 1 and 24 hours).
6. Select the **Backup Drive** to save the backup video under **Select Backup Media** or click **Network Drive**. To save to a local drive or partition you must first rename the location "Backup".
7. Select the **Overwrite on Disk Full** check box to overwrite previous backup files when the disk becomes full.
8. Click **Save Backup Setting** to save the current backup setting and return to the Live View screen.

Specifying Scheduled Backup Drives

In order to use the Scheduled Backup feature one or more storage drives or partitions connected to the recorder must be specified as a backup drive.

1. Exit and restart in Windows mode.
2. Double click the **My Computer** icon on the recorder desktop.
3. Right-click the desired drive to specify as a backup drive for Scheduled Backup and click **Rename**. Rename the drive to 'Backup'. Repeat this process for all drives to use for Scheduled Backup. To remove a drive from use for Scheduled Backup, change its name to something other than 'Backup'.
4. Restart the Fusion application and return to the **Schedule** tab in the **Backup Center** window.

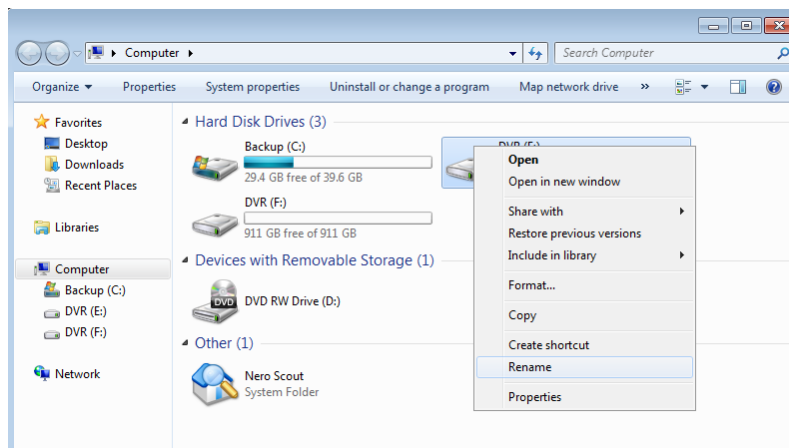

LAN / ISDN / PSTN Connections

LAN Overview

The recorder can be easily connected to a Local Area Network (LAN) and uses Microsoft's® powerful and secure Windows® Embedded Standard 7 operating system. This allows for easy and well-documented instructions on setting up LAN connections no matter what type of LAN you want to use.

A LAN is a group of computers and other devices dispersed over a relatively limited area and connected by a communications link that allows one device to interact with any other on the network.

There are many reasons why using Microsoft Embedded 7 is superior to other platforms when running on a LAN. The number one reason is security. Running the recorder on a secure network is important to prevent unwanted users from gaining access to confidential information. Unwanted users can compromise the integrity of the confidential data being stored and viewed, and in extreme circumstances can cause irreparable damage to the network.

Since connecting the recorder to a network can be extremely complex (depending on the network), this Fusion recorder manual will cover only the basics. It is suggested that the recorder administrator consult the Vendor or IT Administrator before attempting to create or connect to a LAN.

Connecting to a LAN Using TCP/IP

The networking options of the recorder can create and edit all Network settings available on Windows Embedded 7. The recorder comes equipped with a 10/100/1000 Network Interface Card (NIC). This card uses a standard RJ-45 Ethernet connector.

Configuring TCP/IP Settings

1. On the Live View screen, click **Exit** and select **Restart in Windows Mode**.
2. Right-click the **Network** icon located on the desktop and select **Properties**.
3. Click **Local Area Connections** and then click **Properties**.
4. Select the Internet Protocol (TCP/IP) by clicking on it once. Once it is highlighted, click **Properties**.
5. Select **Use the Following IP Address** option. Enter the **IP Address** and **Subnet** mask appropriate for the network. It is recommended to contact the Network Administrator for appropriate IP settings.

Example:

- a. Common IP addresses are 10.0.0.25
- b. Common Subnet masks are 255.255.255.0

Note In order to connect to the recorder through a remote LAN connection, a static IP address must be assigned. If the network assigns the IP address automatically (DHCP), contact the Network Administrator for help assigning a static IP address.

6. If the network requires you to specify the DNS information, enter it now by selecting the appropriate DNS options.
7. When finished configuring the TCP/IP settings click **OK** to close the **Internet Protocol (TCP/IP) Properties** window.
8. Click **OK** to close the **Local Area Connection Properties** window.
9. It may be required to restart Windows for the changes to take effect. Restart windows by clicking the Start button  on the desktop and clicking **Restart**.

LDAP Integration

Features

The instructions below are for LDAP Integration with Server Software version 3.6.36 and above.

- The recorder server does not need to be joined to the Domain. The recorder server will query the LDAP server for accounts and authorization levels.
- The recorder server creates groups within Active Directory for each of the permissions on the recorder. Simply join a Domain user to these groups to provide access to that function in the recorder.
- Recorder access within Active Directory is based on the Site Code within the recorder software. This allows an administrator to group recorders with the same Site Code.
- Remote and Multi-Site management software works with LDAP logins.

Installing LDAP

Required Items

- Name of LDAP server.
 - Account in LDAP server that has Domain Admin rights. This user will be used initially to create the OU's and Groups within Active Directory.
1. Verify that the recorder server is connected to a network that has a valid LDAP (Active Directory) server.
Ensure that the TCP/IP settings are configured correctly for DNS resolution and gateway if needed.
Check to verify that you can ping the LDAP server without issues.
 2. Set up DVR Site Code to be used for LDAP authorization. The default will be 100-000. This site code can be used to group recorders together within Active Directory.
 3. Log in to the recorder using the local recorder administrator account (non-LDAP).
 4. Navigate to the Setup -> Information tab and change the Site Code.
 5. Log on to the recorder server with the domain account with administrator privileges (see above required items).
If successful, the recorder will log the administrator user on without any error messages. You may log off the recorder once this is completed without errors.

Note If you encounter an error please verify that the above required items are correct.

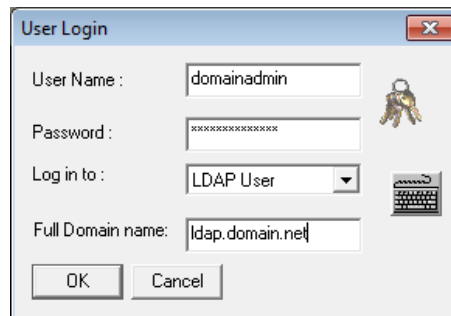

6. Go to the Active Directory Users and Computers application. You should now see an OU called DVR with an OU inside of it named the same as the Site Code above (example 100-000).

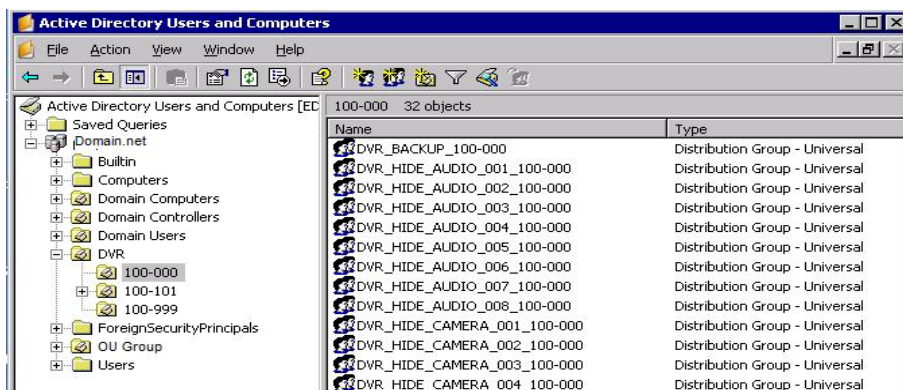

7. You can now add users within Active Directory to the groups the recorder has created. When a user belongs to a group he or she will have access (or be denied access in the case of Audio or Camera channels) to that permission on any recorders with that site code.

Group	Description
DVR_BACKUP_100-000	Backup access to DVRs with site code 100-000
DVR_HIDE_AUDIO_0XX_100-000	Hides audio channel XX for site code 100-000
DVR_HIDE_CAMERA_0XX_100-000	Hides camera XX for DVRs - site code 100-000
DVR_INSTANT_100-000	Instant recording access to DVR
DVR_PTZ_100-000	PTZ access to DVRs - site code 100-000
DVR_PTZEX_100-000	Access to advanced PTZ control
DVR_RELAYOUT_100-000	Access to toggle relays from live view
DVR_SEARCH_100-000	Access to search on DVRs - site code 100-000
DVR_SETUP_100-000	Access to setup on DVRs - site code 100-000
DVR_SHUTDOWN_100-000	Grants the ability to shut down the DVR server

Note The above site codes may be different depending on what site code the recorder server had when it was logged into LDAP.

8. You can now log into the recorder server using any of the Active Directory users who belong to one of the above groups.

Web Viewer

Web Viewer Overview

The web viewer is the ideal way to connect to the DVR for anyone who only needs to view live cameras. It is compatible with Internet Explorer 6.0 and later.

Highlights:

- View Live Video from most computers
- Username and Password protected
- Easy to use graphical interface

Basics:

75 users can access the Web DVR simultaneously. The Web Viewer is an easy, secure way to view live video from virtually any computer with an internet connection using Microsoft Internet Explorer.

To log in to the DVR server from the Web Viewer, a user account must be made for the user. This ensures that only authorized users are allowed to log in. In addition, each user can be assigned different privileges that allow or deny them access to different functions.

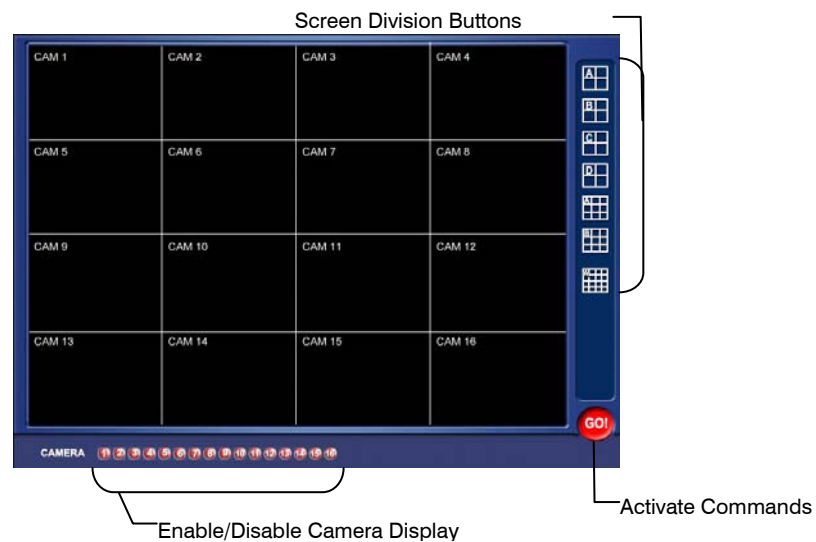

Configuring the Server for Remote Connection

1. Enter Setup on the DVR.
2. Click the Network Setup tab.
3. Clear the Disable Remote Control check box. Adjust port settings if necessary.

Note If using a Firewall, it may be necessary to adjust the port settings on both the DVR and the Firewall. Contact the Network Administrator for more information.

4. Select the Enable Web Viewer option. Again, adjust port settings if necessary
5. Click OK.
6. Make sure a User account is created. Without a user account, the Administrator account must be used.
7. The DVR server is now ready to receive incoming connections.

Connecting to a DVR Using Web Viewer

1. Open Microsoft Internet Explorer.
2. Enter the IP address of the DVR into the Address Bar.
3. When attempting this for the first time you will be asked to accept an Active X installation. Select Yes to this.

Note If you receive a message saying Internet Explorer security settings do not allow you to download Active X components then you will need to adjust the browser security settings. One way to do this is to add the IP address of the DVR to the trusted sites list inside Internet Explorer settings. Contact the System administrator for additional help with adjusting Internet Explorer settings.

4. When the Web Viewer finishes loading, select one or more cameras (or select a screen division button).
5. Click GO!
6. A login window will appear. Enter the Username and Password of an authorized user.
7. The cameras will now be displayed.

Closing the Web Viewer

- To exit the Web Viewer close Internet Explorer.

Included Software Setup

Proprietary Viewer Overview

The Proprietary Viewer plays back the exported video in its proprietary format. Video saved in this format is extremely difficult to tamper with and therefore is the ideal solution when law enforcement and legal departments are involved. This video cannot be read by any other viewer.

The Proprietary Viewer is essentially the Search portion of the DVR software. For detailed explanation of these functions, refer to the Search Chapter in this manual.



Installing the Proprietary Viewer

1. Insert the Software Installation CD into the CD-ROM. (Do not install on the DVR.)
2. Select the Proprietary Viewer option to begin installation. When the Welcome screen appears, Click the Next button
3. When the Choose Destination Location Window appears Click the Next button. This will install the Proprietary Viewer in the default destination folder.
4. When the Select Program Folder Window appears Click the Next button.
5. Select either 16 or 32 channel option depending on the model. The user can always reinstall and change this option at a later date. Click the Next button.
6. Click Finish.

Loading Video from DVD-ROM or Hard Drive

1. Open the Proprietary Viewer program by selecting Start > Programs> Fusion > Proprietary Viewer > Proprietary Viewer.
2. Select Backup Search (see the Performing a Basic Search section) and the Total Backup Search window opens.

3. Click the Chose Time to Search tab.
4. For CD-ROM data, select the appropriate CD-ROM drive letter from the Backup Media box.

For hard drive data, select either an attached hard drive from the Backup Media box or select the Open Folder icon to browse to the specified directory.

Once selected, any available video will be displayed in the Choose Start Hour box.

5. Click on the desired time to select it.
6. Click OK.
7. The video will now load into the Proprietary Viewer. To view the video, follow the instructions for searching as described in the Search chapter.

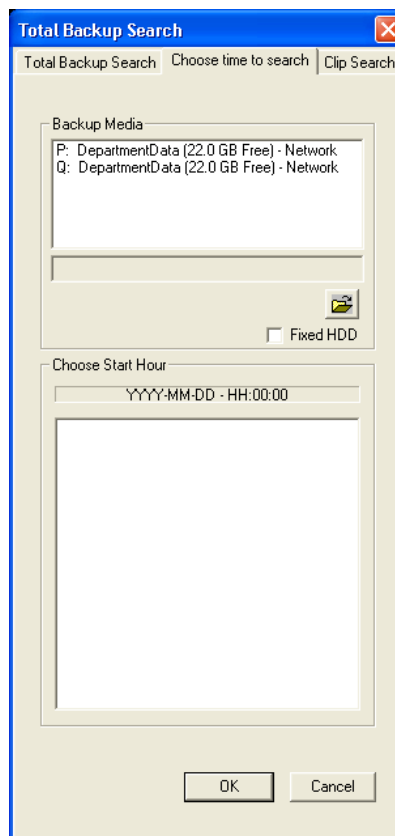

Digital Verifier Overview

.JPG images and .AVI video files that are exported from the Digital Video Recorder are automatically embedded with a digital signature. Digital Signatures are a way to verify the authenticity of the images to ensure that they have not been tampered with or edited in any way. Included on the Software Installation DVD, supplied with the DVR, is the Digital Signature Verification program. This program can be installed on any computer and loads an image in question.

Installing the Digital Verifier

1. Insert the Software Installation CD into the CD-ROM. (Do not install on the DVR.)
2. Select the Digital Verifier option to begin installation. When the Welcome screen appears, click Next.
3. When the Setup Complete window appears click Finish. Installation is complete.

Using the Digital Verifier

1. Open the Digital Verification program by selecting Start > Programs > Fusion > Digital Verifier > Digital Signature Verifier.
2. Click the Browse button to load the .JPG image.
3. Enter the Site Code of the DVR that the image was originally extracted from. (The Site Code is specified in the Site Information Setup Menu)
4. Click the Verify button to continue or Close to close the window without verifying.

If the image has not been tampered with, a blue square will appear around the image with the message "Original image file."

If the image has been tampered with, a red square will appear around the image with the message "Entire image changed or wrong SITE CODE."

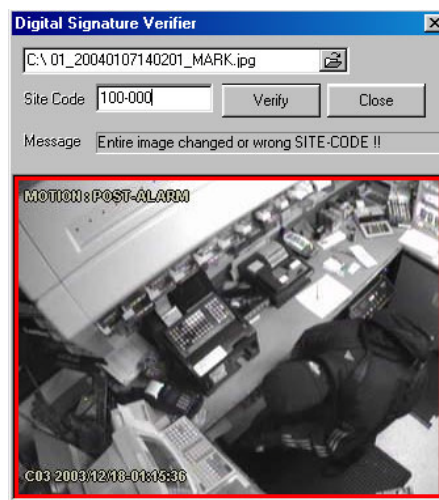
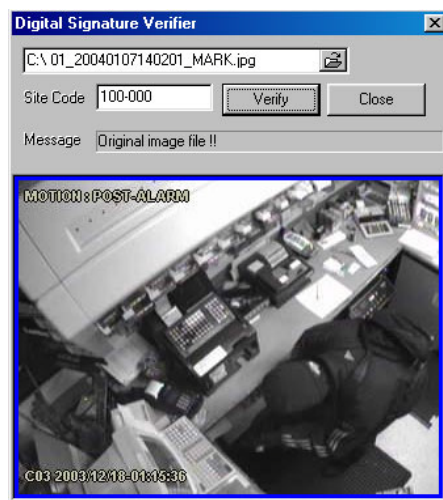

Alarm Monitor Overview

The Alarm Monitor software is a utility that streams video across a Local Area Network to a Client PC when an alarm is detected on the DVR. The video that streams across can be stopped, played forwards and backwards, in slow motion or real time. The utility is loaded at startup and placed in the taskbar. It constantly monitors for a signal from the DVR. When an alarm signal is detected the Alarm Monitor Image Viewer Window opens and starts playing the video from the camera associated to the alarm.

Installing the Alarm Monitor

1. Insert the Software Installation Disc into the CDRom. (Do not install on the DVR) Select the Alarm Monitor option to begin installation and accept the license agreement.
2. Follow the on screen instructions.
3. Click the Finish button to complete the installation.

Configuring the DVR

To enable the Alarm Monitor on the DVR follow these steps:

1. Enter Setup and click the Recording Schedule tab.
2. Assign the desired sensors to the desired cameras. Refer to the Recording Schedule section of this manual for in depth instructions on how to do this.
3. Enable Sensor Event and/or Motion Event in the Alarm Options Section of each schedule number to send alarm events to the Alarm Monitor.

Note The Remote Alarm and Emergency Alarm options are used by the more advanced FVMS multi site management and control software.

4. Enter the IP Address of the computer running the Alarm Monitor software.
5. Click the Network tab and make sure that Disable Remote Control is not checked.
6. The Alarm Monitor uses the Emergency Port to transfer the data through. The port can be adjusted inside the Network Menu if necessary. It is recommended that the default port setting be used.
7. Click the Sensor Menu tab.
8. Configure the Sensors assigned to cameras.
9. Click OK.

Configuring the Client PC

All configurations take place in the Alarm Monitor Window on the client PC. For descriptions and locations of the buttons and features of the Alarm Monitor Window, refer to the Alarm Monitor Window section later in this chapter.

1. Open the Alarm Monitor Window on the Client PC. Start > Programs > Fusion > Alarm Monitor > Alarm Monitor.
2. Click New in the DVR List and enter the site code, site name, and IP Address of the DVR in the Site Edit window. Click Save.

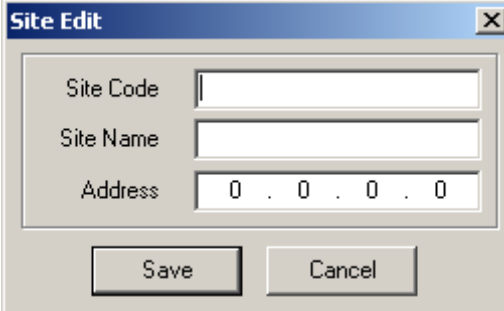

The image shows a 'Site Edit' dialog box with the following fields and buttons:

- Site Code:
- Site Name:
- Address:
- Buttons: Save, Cancel

Note The site code can be found under the Information tab in the Setup Menu.

3. Click the Tools Menu and select Setup.
4. Confirm that the Listen Port in the Configuration Window is set to the same number as the Emergency Port in Communication Settings on the DVR. If the numbers are different adjust the Listen Port on the client PC to match the DVR.
5. Click Enter.
6. Reboot the client PC.

Alarm Monitor Window

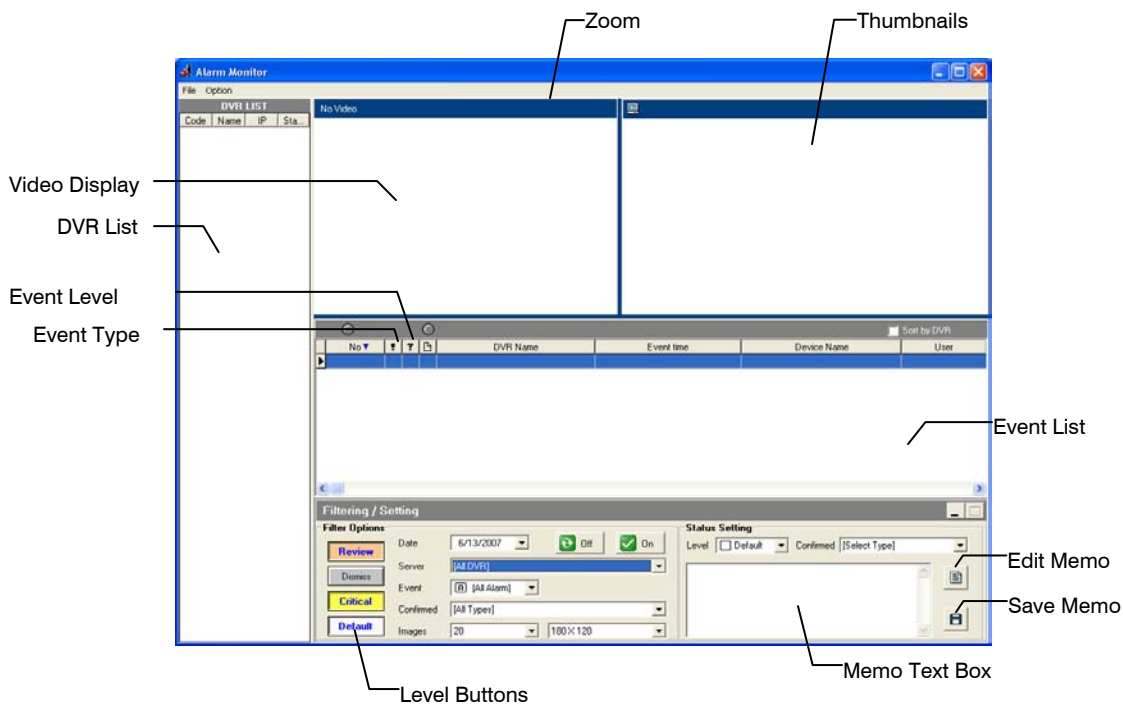

Filter Event List

1. Select a DVR from the Server list under Filter Options.
2. Select the Date to include.
3. Select the type of Events to include.
4. Select the event levels (Review, Dismiss, Critical, Default).
5. Click the On button to display filtered event listings.

Search Alarm Window

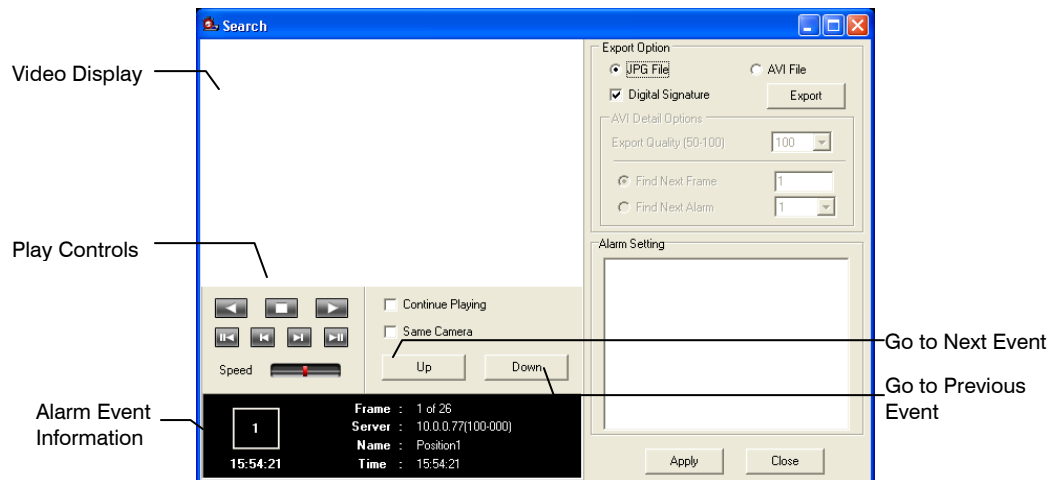

Export Quality

It may be necessary to reduce the overall size of an .AVI file; for example, to email to someone. .AVI file sizes can be reduced by reducing the image quality. When size is not an issue, setting quality to 100 is highly recommended.

Digital Signature

Adds a digital signature to the exported .JPG image for use with the Digital Signature Verifier to verify integrity of exported images and prevent tampering.

View Recorded Video

1. Double click an event listing to open the Search window.
2. Use the play controls to locate the desired video.
3. Select the Continue Playing check box to watch all recorded events. When not selected, playback stops at the end of the alarm event.
4. Select the Same Camera check box to watch all events recorded by a single camera.
5. Click Apply after making any changes.

Export Video

1. Double click an event listing to open the Search window.
2. Use the play controls to locate the desired video.
3. Click the Rewind button to return to the beginning or desired spot in the video.
4. Click the Stop button and select the Export Type – JPG or AVI.
 - a) **Save JPG:** Select the Digital Signature check box to embed a digital signature in a JPG file and click Export.
 - b) **Save AVI** Reduce Export Quality only if necessary to reduce the size of the file and click Export.

Fusion Remote Software Overview

The DVR was specifically designed to be fully operated and maintained remotely. It connects using the standard TCP/IP protocol through connection types such as DSL, Cable Modem, T1, ISDN, 56K Modem, LAN, and more. The Fusion Remote software provides for viewing live video, searching through archived video, exporting images and video clips; and provides virtually full Setup control.

Highlights:

- Search Archived Video
- View Live Video
- Export Images and Video Clips
- Control Relay Outputs
- Setup Administration

Basics:

The DVR can have up to five simultaneous remote connections. Each user can perform functions on the DVR and will not affect the other users. The only exception to this is accessing Setup. Only one user is allowed to access setup at any given time. The Frames per Second passed to the Remote Client varies greatly depending on the connection type and speed.

In order to log in to the DVR server, a user account must be made for the user. This ensures that only authorized personnel are allowed to log in. In addition, each user can be assigned different privileges that allow or deny them access to different functions. (See the User Management section.) For example, a user can be denied Searching and Setup privileges and only granted access to view cameras 4, 8 and 16.

Attention It is highly recommended that users not be granted Setup privileges since this can pose a security risk. Only authorized Administrators should have access to Setup.

The Remote software operates virtually the same way as the DVR itself. Its appearance matches the DVR almost identically, however, there are a few minor differences. Some search features are not available as well as some Setup options.

Remote Client Minimum Requirements

- Windows® 7, Vista or XP Operating System
- Intel Dual Core
- 1 GB RAM
- 256 MB+ NVIDIA or ATI Video Card
- DirectX 9 or Higher
- 256k Network Connection (Lower speed network connections can cause a loss in performance or connection stability)
- 32 bit Color
- 1280x1024 Resolution

Remote Client Recommended Requirements

Note The follow system requirements are the minimum requirements for any system receiving data from a DVR using H.264 hardware compression.

- Windows® 7, Vista or XP Operating System
- Intel Core 2 Duo 2.8GHZ
- 2 GB RAM
- 256 MB+ NVIDIA or ATI Video Card
- DirectX 9 or Higher
- 256k Network Connection (Lower speed network connections can cause a loss in performance or connection stability)
- 32 bit Color
- 1280x1024 Resolution

Installing the Fusion Remote Software

1. On the client computer, insert the Honeywell Fusion Software CD into the CD-ROM. The CD should run automatically.
2. When prompted, select the Install Fusion Remote Software option. Follow the installation instructions carefully.
3. When the software finishes installing, close any open installation windows.

Setting up the Server to Accept Incoming Communications

In order to access the DVR remotely, the DVR Server must be setup to allow remote connections.

Disable Remote Control Enables/Disables acceptance of remote connections by the DVR server.

Time Out Value Specifies a value (in seconds) to wait for a signal from the Fusion Remote Client. If a signal is not received by that time, the connection is dropped.

Center Port Used by the DVR to transfer the connection data.

Image Port Used by the DVR to transfer the image data.

Search Port Used by the DVR to transfer the search data

1. Enter Setup on the DVR.
2. Click the Network tab.
3. Clear the Disable Remote Control check box.

Note If a Firewall is used, it may be necessary to adjust the port settings on both the DVR and the Firewall. Contact the Network Administrator for more information.

4. Click OK.
5. Make sure a User account is created. Without a user account, the Administrator account must be used.
6. The DVR server is now ready to receive incoming connections.

Setting up the Fusion Remote Software

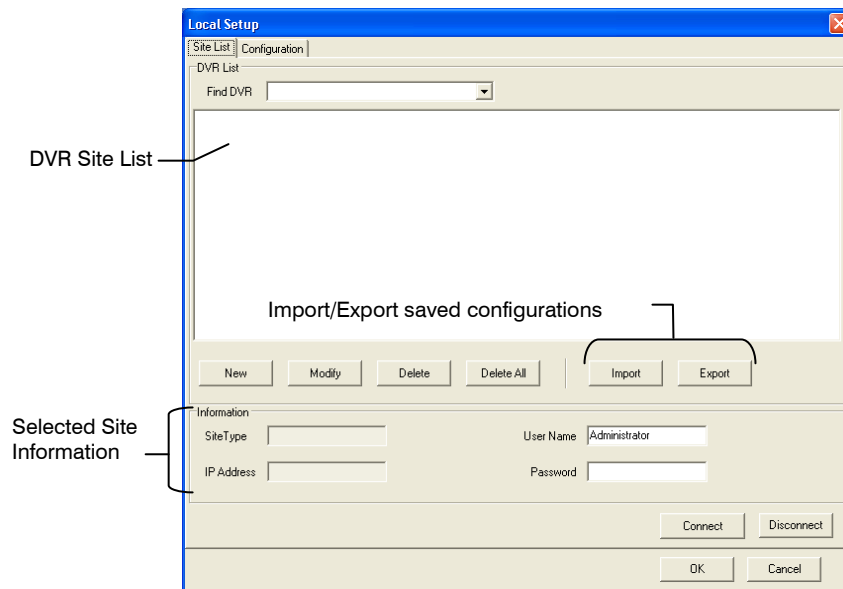

Creating a New Remote Connection

1. Select Start > Programs > Fusion > Fusion Remote.
2. Click New to open the Site Info window.
3. Enter the Site Code and Site Name. The Site Code can be found on the Information tab on the Fusion DVR.
4. Enter the IP Address of the DVR server. By default the DVR is set to connect using DHCP.
5. Enter the Center Port. This setting is specified on the server on the Network tab
6. Click OK.
7. Click on the newly created connection and enter the username and password.
8. Click Connect.

FVMS Overview

FVMS software is Multi-Site Management Software; a powerful utility that allows 100 or more DVRs to be controlled using one computer. This software allows you to view live video, search saved video, edit and configure setup on each DVR, and import maps of buildings and other locations.

The FVMS software was specifically designed as a multi-site capable, central management software solution.

Highlights:

- Multi-site operation
- View Live Video from most computers
- Search and playback - zoom in to stored video from megapixel cameras
- Username and Password protected
- Easy to use graphical interface

Basics:

In order to log in to the DVR server, a user account must be made for each user. This ensures that only authorized personnel are allowed to log in. In addition, each user can be assigned different privileges that allow them or deny them access to different functions.

FVMS System Requirements

Minimum	Recommended¹
Intel Core 2 Duo 2.8 Ghz (or equivalent) ²	Intel Quad Core i7 processor (or equivalent) ²
1 GB System Memory	2 GB System Memory
DirectX 9 or Higher	DirectX 9 or Higher
256 MB+ NVIDIA or ATI Video Card. ³	ATI 5750 Video Card (or equivalent) ³
256k Network Connection ⁴	512k Network Connection ⁴
TCP/IP Installed	TCP/IP Installed
Microsoft Windows [®] 7, Vista, or XP ⁵	Microsoft Windows [®] 7, Vista, or XP ⁵
1280 X 1024 Optimal Display Resolution	1280 x 1024 Optimal Display Resolution
32 Bit Color	32 Bit Color Depth

- 1 Minimum requirements for Software H.264 and highly recommended for MegaPixel image rendering.
- 2 FireMV, NVS and CAD cards are not supported. Dual video cards required for four monitor output. SLI/Crossfire not supported.
- 3 Gigabit network highly recommended for LAN environments and configurations running multiple megapixel cameras.
- 4 No support for Server operating systems

Configuring the Server for Remote Connection

1. Enter Setup on the DVR.
2. Click the Network tab.
3. Clear the Disable Remote Control check box.

Note If you are using a Firewall, it may be necessary to adjust the port settings on both the DVR and the Firewall. Contact the Network Administrator for more information.

4. Click OK.
5. Make sure a User account is created. Without a user account, the Administrator account must be used.
6. The DVR server is now ready to receive incoming connections.

Connecting to a DVR

Refer to the Setup section of the FVMS Manual for information on using the FVMS Software. The FVMS Manual can be found on the Fusion Software CD.

Health Check

FVMS Health Check is used to monitor the status of Network, Video, Recording, and HDD storage space on remotely connected Fusion DVRs. Health Check also provides the user with detailed information on each of the DVRs connected, including the software version running, whether cameras are recording in Motion or Continuous mode and other important information. The DVR transmits this information on port 4005 (default). You can also enable E-mail alarms to be sent on a Health Check Event (Warning or Failure event).

Highlights:

- Can monitor multiple DVRs on the Health Check Main page – up to 100 DVRs.
- Able to define the number of occurrences before a Warning or Failure alarm is triggered.
- Check interval times allow FVMS to check the Fusion DVRs status once every 10 minutes or up to once every 7days.
- Independently enable or disable Health Check on each connected Fusion DVR.
- Independently select warning and failure notification counts for Video Loss, Recording failures, Disk Free Space %, and Storage Failures.
- Enable custom Voice Warning on Failure alert.
- Detailed status screen provides the following information:
 - DVR Information: including last Health Check time, Total # of channels recording, DVR software version running, current working drive, and disconnected time.
 - Video and Recording information: including the recording status of each camera channel and whether or not it is Motion or Continuous, and if there is a Video Signal from each of the channels
 - HDD Storage Status Bar: indicates the amount of Free and Used space remaining on the HDD.
 - Enable an E-mail to be sent on a Warning or Failure Health Check Event – Enabled through the Admin>Enable Email Alarm setup window.
 - Ability to Export Status Summary Information, from each independently selected DVR, to HTML, TXT, or Excel formats.
 - Summary information of Network Status, Disk Status, Video Status, Capture Status and Storage Status indicating Good, Warning or Failure, along with the specifics about each. Also includes the overall Total status of the DVR.

Enable Health Check on the Fusion DVR

1. Enter Setup on the DVR.
2. Click the Network tab.
3. Clear the Disable Remote Control check box.
4. Select the Enable Health Check check box.

Note The default connection port is 4005; only change this if necessary.

5. Click Apply.
6. Click OK.

Honeywell Systems (Head Office)

2700 Blankenbaker Pkwy, Suite 150
Louisville, KY 40299, USA
www.honeywellvideo.com
☎ +1.800.796.2288

Honeywell Systems Europe/South Africa

Aston Fields Road, Whitehouse Industrial Estate
Runcorn, Cheshire, WA7 3DL, UK
www.honeywell.com/security/uk
☎ +44.01928.754028

Honeywell Systems Caribbean/Latin America

9315 NW 112th Ave.
Miami, FL 33178, USA
www.honeywellvideo.com
☎ +1.305.805.8188

Honeywell Systems Pacific

Level 3, 2 Richardson Place
North Ryde, NSW 2113, Australia
www.honeywellsecurity.com.au
☎ +61.2.9353.7000

Honeywell Systems Asia

35F Tower A, City Center, 100 Zun Yi Road
Shanghai 200051, China
www.asia.security.honeywell.com
☎ +86 21.5257.4568

Honeywell Systems Middle East/N. Africa

Post Office Box 18530
LOB Building 08, Office 199
Jebel Ali, Dubai United Arab Emirates
www.honeywell.com/security/me
☎ +971.04.881.5506

Honeywell Systems Northern Europe

Ampèrestraat 41
1446 TR Purmerend, The Netherlands
www.honeywell.com/security/nl
☎ +31.299.410.200

Honeywell Systems Deutschland

Johannes-Mauthe-Straße 14
D-72458 Albstadt, Germany
www.honeywell.com/security/de
☎ +49.74 31.8 01.0

Honeywell Systems France

Immeuble Lavoisier
Parc de Haute Technologie
3-7 rue Georges Besse
92160 Antony, France
www.honeywell.com/security/fr
☎ +33.(0).1.40.96.20.50

Honeywell Systems Italia SpA

Via della Resistenza 53/59
20090 Buccinasco
Milan, Italy
www.honeywell.com/security/it
☎ +39.02.4888.051

Honeywell Systems España

Avenida de Italia, nº 7
P.I. - C.T.C. Coslada
28820 Coslada, Madrid, Spain
www.honeywell.com/security/es
☎ +34.902.667.800

Honeywell

www.honeywellvideo.com
+1.800.796.CCTV (North America only)
HVSsupport@honeywell.com

Document 800-03703V1 Rev B– 10/11

© 2011 Honeywell International Inc. All rights reserved. No part of this publication may be reproduced by any means without written permission from Honeywell Video Systems. The information in this publication is believed to be accurate in all respects. However, Honeywell Video Systems cannot assume responsibility for any consequences resulting from the use thereof. The information contained herein is subject to change without notice. Revisions or new editions to this publication may be issued to incorporate such changes.