

Other Access Control Products

standalone products

Also available is a range of fully functional standalone door controls for less complex door management. This attractive design, with modern aesthetics, will complement and building.

- 1 and 2 Door Digital Keypads
- Proximity Switch
- Biometric Switch

Features:

- (35 - 1000) users
- Access control
- Door monitoring
- Manager user
- fire and intruder alarm interface
- Backlighting
- Tamper resistant
- 5 amp relays
- Indoor or outdoor use
- Robust polycarbonate housing with stainless steel keys
- Mounts onto a standard electrical back box



Contents

Installation Instructions	3
Installation Diagrams	4
System Overview	6
Wiring Diagrams	8
Network Diagrams	9
Operating Instructions	12
Fingerprint Enrollment	19

Wi-Enterprise Controller

Simple Secure Access

www.argusaccess.com

Installation & User Manual v2.062



Technical Specs - Wi-Enterprise Controller

Power Supply	230 VAC
Current consumption	30mA
Fuse Rating	230VAC 315mA T
Moisture Resistance	Indoor Use Only
Dimensions	W. 260mm D. 262mm H. 55mm

Technical Specs - Wi-Enterprise Door Controls

Power Supply	12 DC
Current consumption	110mA
Current consumption with load (max)	145mA
Relay Contact Rating	5 Amps /230V ac
Operating Temperature	- 20°C to +60°C
Moisture Resistance	IP 67 (IP65 on Wi-Bio)
Dimensions - Flush Mount	W. 87mm D. 21mm H. 119mm
- Surface Mount	W. 87mm D. 35mm H. 119mm

Features

Doors controlled	20
Users	20000
User Groups	128
Time Zones	128
Door Groups	128
Reporting Facility	Yes
Challenge Facility	Yes
Logging	Unlimited
Input/Output Mapping	CCTV & Lift control
Supports Wireless & RS485 Networks	Yes
Automatic Backup Facility	Yes
Database Encryption	Yes



Installation Steps

Step	Description	Page
1	Install the Controller using the Installation Diagrams	4-5
2	Wire the Controller using the Wiring Diagrams	8
3	Install and wire each Door Control. Refer to the Door Control Manual for instructions.	
4	Connect the Controller to the PC using Network Diagrams	9-11
5	Restoring Factory Defaults	11
6	Setting up TCP-IP	12
6	Phase 1- Setting up the Controller	14
7	Phase 2 - Configuring the Controller	15
8	Phase 3 - Enrolling Door Controls	16-18
9	Phase 4 - Configuring Users	19
10	Phase 5 - Configuring Access Levels	20
11	Phase 6 - Downloading Configuration	20
12	Enrolling User Fingerprints	21
13	Correct Finger Placement techniques	22-25



Control Panel opening

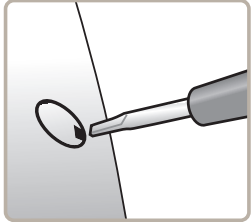

remove screw cap

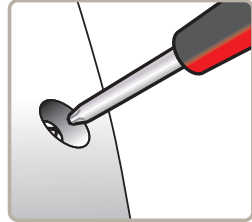

remove retaining screw

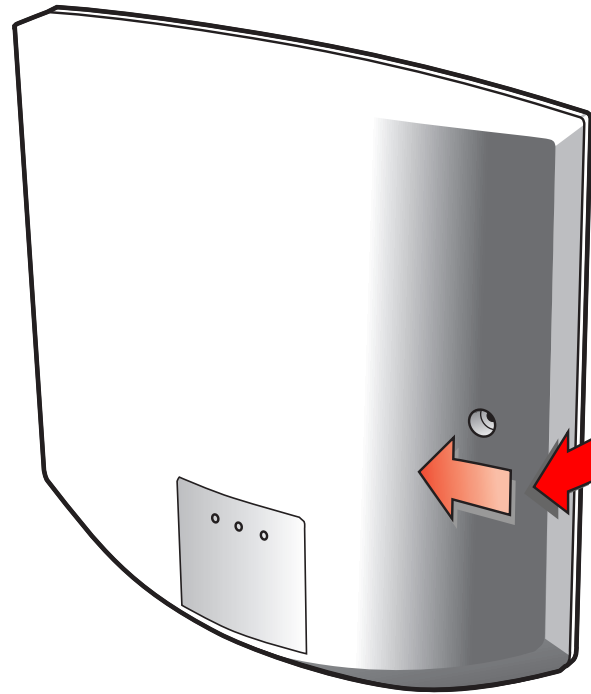

to remove cover
pull forward on
right and slide left



Control Panel features

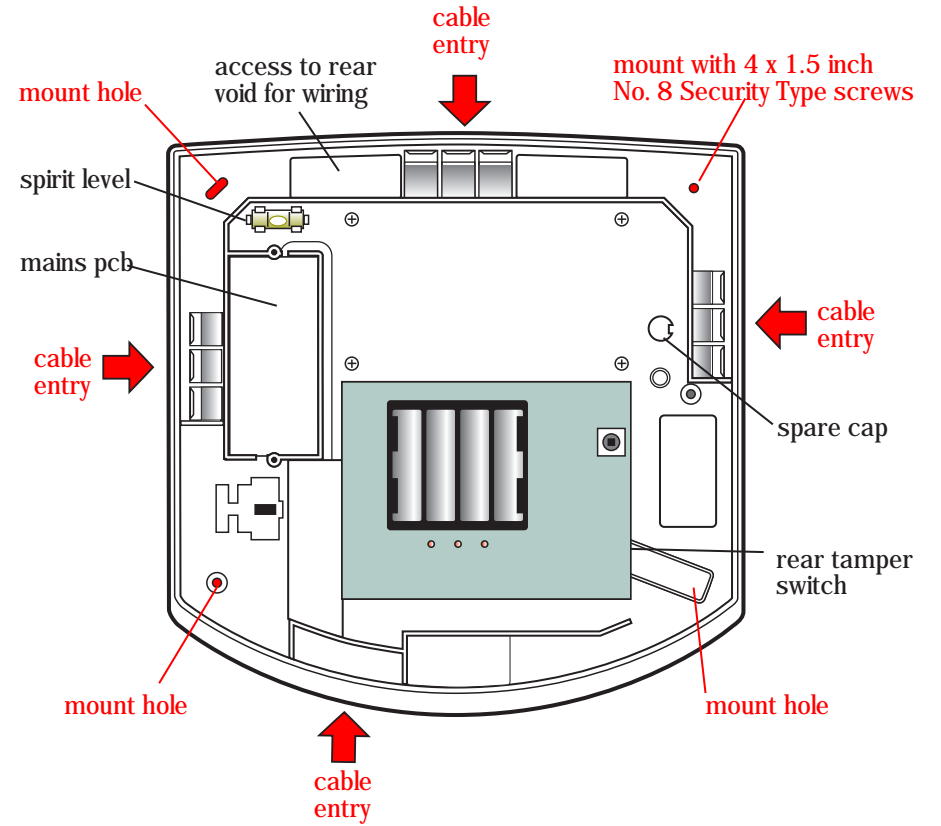



RS485 Connection to Door Controls

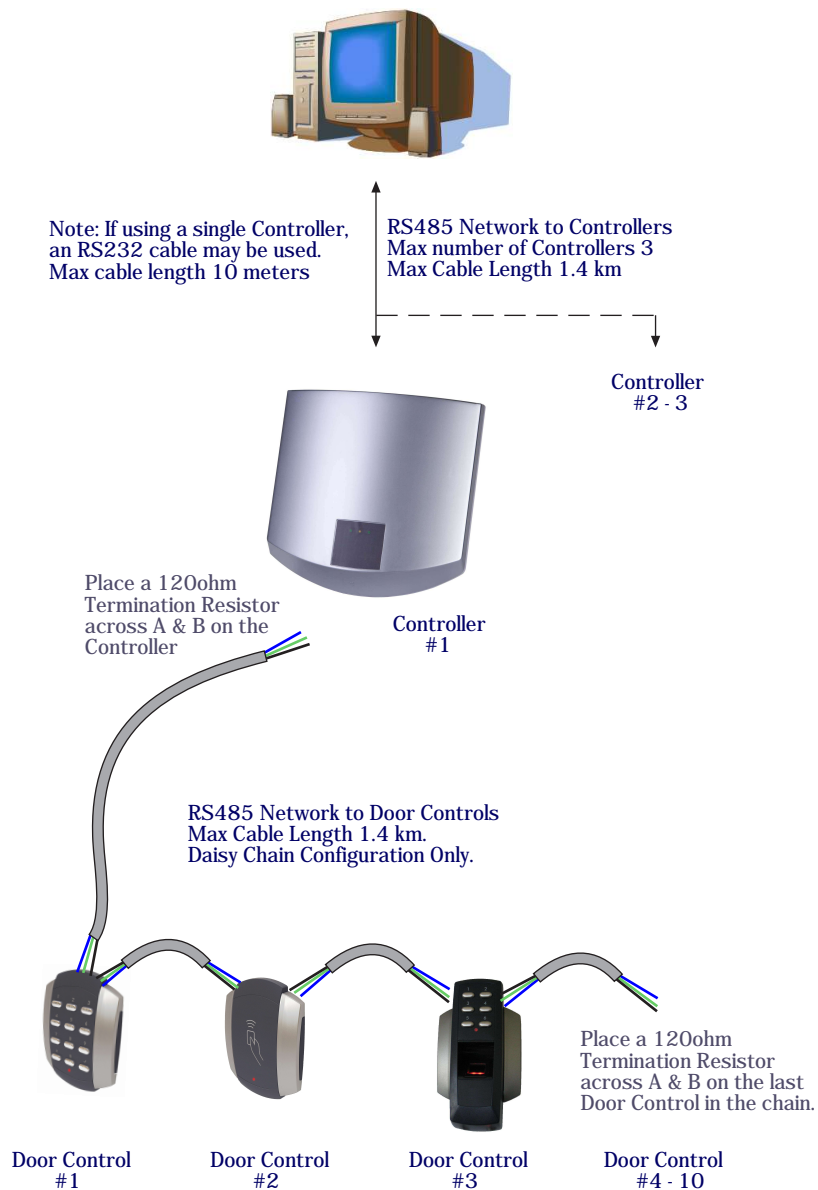

Wireless Connection to Door Controls

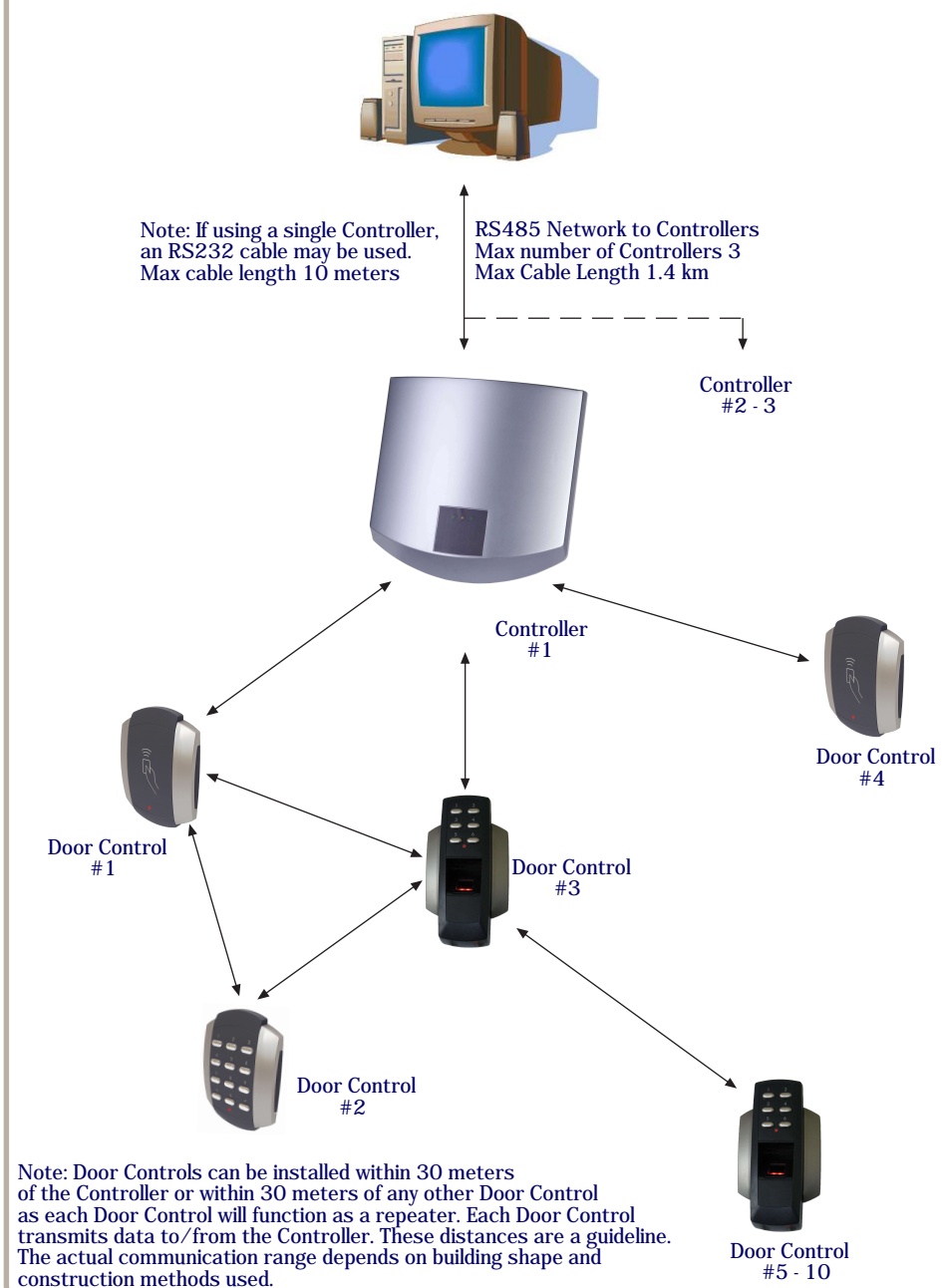



Wiring Diagrams

Warning : Installation should only be carried out by a suitably qualified person only.

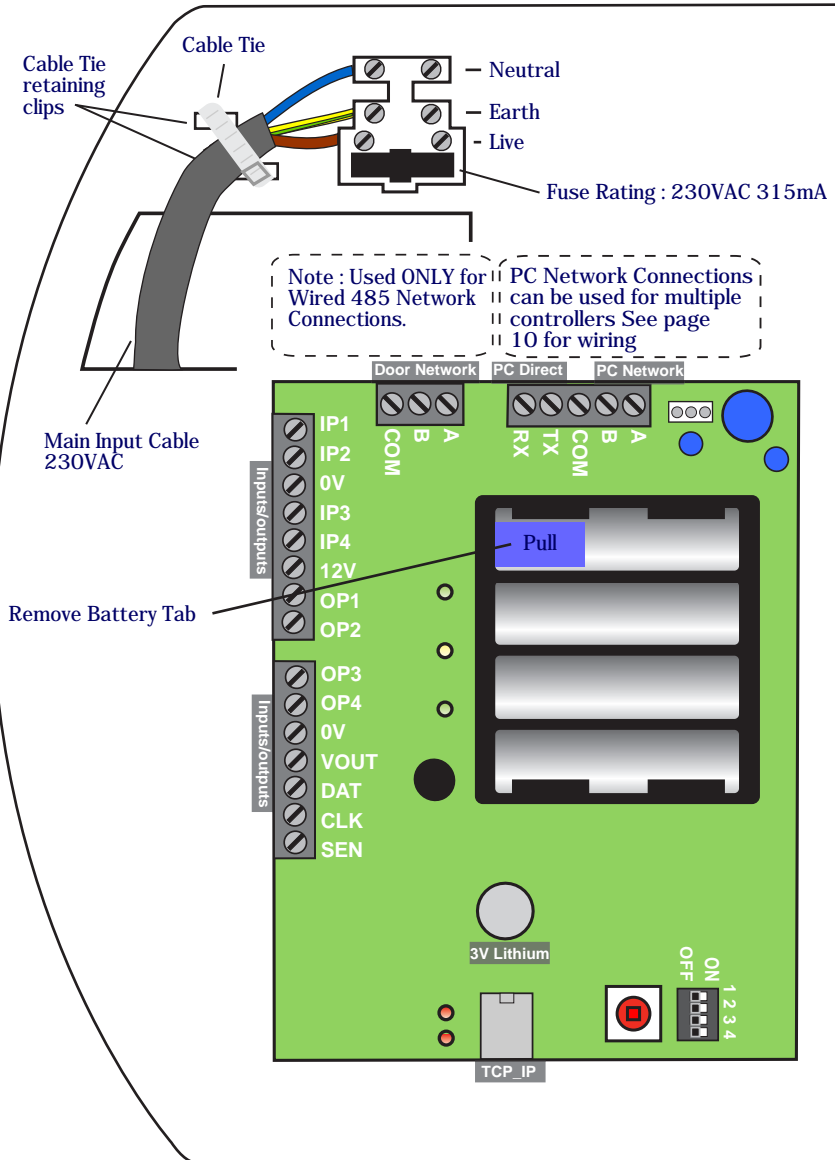

Network Diagrams for Single Controller

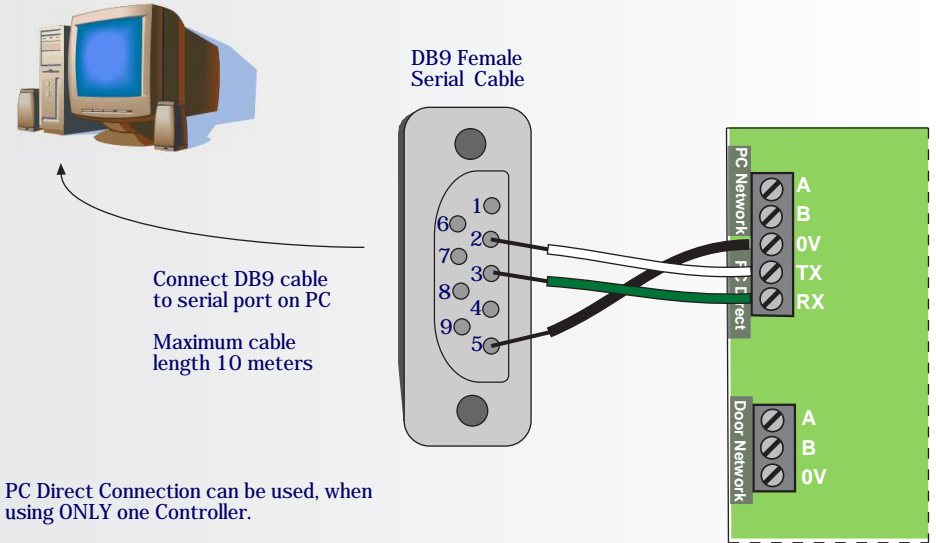

PC Direct Connection can be used, when using ONLY one Controller.

Set the Direct address to ALL dip switches OFF (see below)

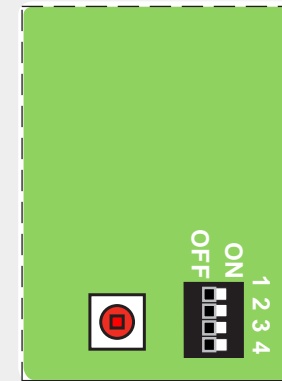

Direct Connect - All Dip Switches OFF

See page 11 on "Configuring Controller Communication" to setup the application for serial communications



Network Diagrams for Multiple Controllers

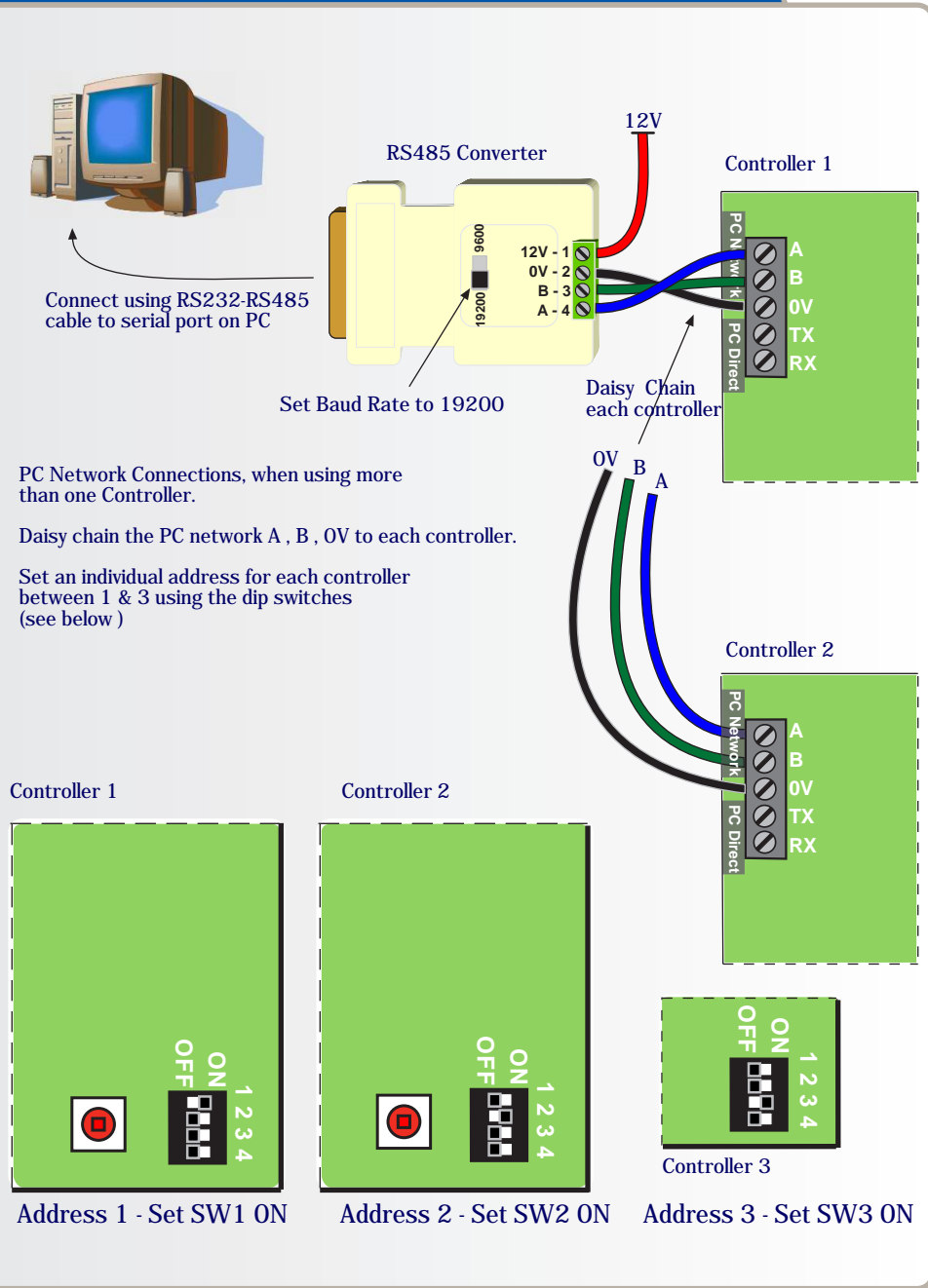

Configuring Controller Communications

Step	Description
1.	On the "Controller" Tab, set the "Connection - Type" to "Serial"
2.	On the "Settings" tab in the communications section, Select the Serial Port number from the drop-down list connected to the Controller.

Setting the Controller address

The Controller Address is set by configuring the Dip switches as shown below.

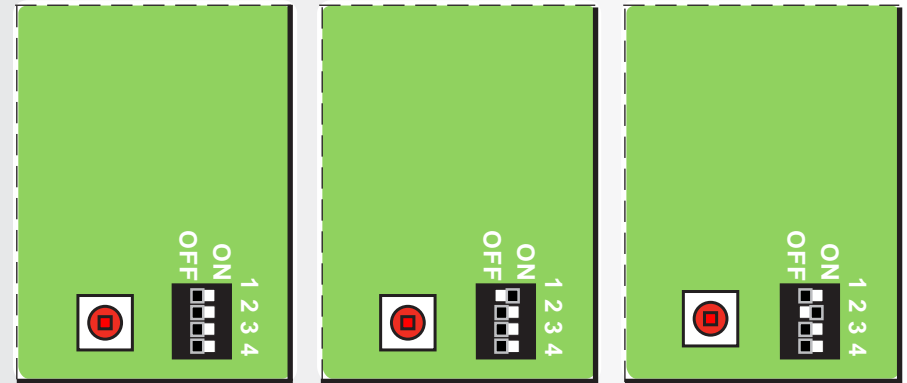

Direct Connect - All OFF Address 1 - Set SW1 ON Address 2 - Set SW2 ON
Note: Address 3 - Set SW3 ON only

Restoring Factory Settings

To restore the factory default setting , Set ALL Dip Switches 1,2,3 & 4 to the ON position and then power-up the Controller.

Example: All Dip Switches are set to the ON position.

Note: Factory Default settings will be restored after powering up the controller with All dip-switches ON. The dip-switches's should then be set to the controller address as shown above in section "Setting the controller address"



Setting up TCP/IP - DHCP

Step	Description
1.	Default the Controller. See Restore Factory settings on page 11. The default TCP/IP mode will then be set to DHCP.
2.	Set the Controller address to address 1. See page 11 for details.
	Connecting the Controller to your DHCP LAN.
1.	Connect the Controller to your LAN using an ethernet cable. The Controller will be assigned an IP address automatically by your DHCP server.
2.	Open the PC application. On the Controller tab, Select TCP/IP with the DHCP option and enter the MAC address of the Controller and click "Apply". The MAC address of the controller can be found on the box or printed on the Controller PCB. The Controller icon will turn blue when it comes online.

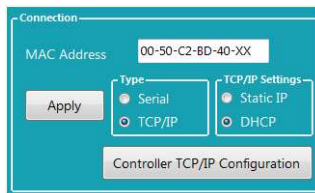

Setting up TCP/IP - Static IP

Step	Description
1.	Default the Controller. See Restore Factory settings on page 11. The Controllers default IP address is 169.254.1.1.
2.	Set the Controller address to address 1. See page 11 for details.
3.	Connect the Controller directly to a PC to using an ethernet cable.
	Connecting the Controller directly to a PC using default IP address..
4.	Connect an Ethernet cable between the Controller and the PC. (The default IP address of the Controller is 169.254.1.1)
5.	Set the IP address on the PC to a similar IP address e.g. 169.254.1.2 Note: If there is no LED activity on your PC's ethernet interface then the PC requires a cross-over cable between the PC and the Controller.
6.	Open the PC application. On the Controller tab, Select TCP/IP with Static option and enter the default Controller IP address of 169.254.1.1 and click apply. The Controller icon will turn blue when it comes online. A new IP address can then be sent to the Controller using the "Controller TCP/IP Configuration" button. Sending a new IP address to the Controller e.g 192.168.1.26.
7.	Make sure the controller is online and click on the "Controller TCP/IP Configuration" button.
8.	Choose Static IP mode and enter the IP address, Netmask and Default Gateway assigned by your network administrator. Click "Send new settings to Controller". The Controller will now go offline as the new IP Address settings are applied.
9.	Connect the PC and Controller to your LAN and enter the new IP address to allow the application to communicate with the Controller. Note: Reset the IP address on your PC to its original setting for your LAN.

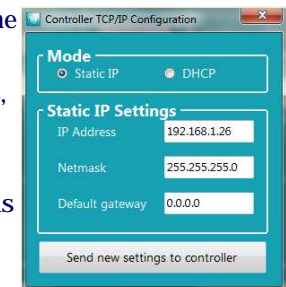



Phase 1 - Setting up the Controller

Step	Description
1.	Install the main Controller and power up
2.	Default the controller immediately via the dip switch settings (see instructions on page 11)
3.	Important! Once powered up and the controller has completed the default the process – reset the dip switches to the correct address positions. (see instructions on page 11)
4.	Follow instructions on the CD provided to install the PC application. Note: Make sure the USB enrollment reader is not connected to the PC before the PC application is installed.
5.	Launch the application: A. Launch the application by clicking the PC app icon on the desktop. B. Click Create a new Wi-Enterprise Site and give it a name of the new installation site. C. Log in to the application as the Engineer (not the administrator) with the password 6666. D. Connect to the Controller. Refer to page 12 & 13 for setting up DHCP or Static IP addresses E. The Controller icon will change colour to show that the Controller is on-line. F. Go to the 'Current Events' tab and verify the log messages indicate the controller is on-line.

Phase 2 - Configuring the Controller

Step	Description
1.	Open the 'Doors' tab in the main menu to add the required number of new doors to be part of this network. One door will already be added by default. Click on the "+" button to add new doors. "-" to remove doors.
2.	Make sure all doors are "Enabled" and then click "Save".
3.	Open the Settings Tab and do a "Configuration Download" to the Controller – this gives the Controller a clean set of instructions before beginning to enroll doors onto the network. This will take approximately 1 minute.
4.	WARNING! A New Network should only be created on first installation. Creating a new network will overwrite any existing network information and any enrolled Door Controls will be un-enrolled. All Door Controls will have to be defaulted and re-enrolled on the new network that has just been created! A new network is now ready to be created. Go to the 'Controllers' tab and Click on the 'Wireless Network' and then the 'Create a New Network' button. Click Yes on the pop-up to proceed. Note: It will take about 20 - 60 seconds to complete. a pop-up will appear when the network has been created.



Phase 3 - Enrolling Door Controls

Step	Description
	All Door Controls should be installed at this point and powered up.
1.	<p>All Door Controls must be defaulted before joining a network. Note: Door Controls will be shipped with their factory default settings. Enter Engineer mode on each Keypad Door Control in the following way</p> <ol style="list-style-type: none"> Press X followed by 6666 Enter 55 –to default Press the tick to confirm – the keypad will now go through the process of defaulting itself. The process could take 20-30 seconds. The LED will flash once every second when it is complete Repeat the process for all keypad Door Controls <p>Enter Engineer mode on each Wi-Bio Door Control in the following way</p> <ol style="list-style-type: none"> Enter 6666 Enter 55 –to default Scan Finger to confirm – the Door Control will now go through the process of defaulting itself. The process could take 20-30 seconds. The LED will flash once every second when it is complete. Repeat the process for all Wi-Bio Door Controls <p>Enter Engineer mode on each Prox Only Door Control in the following way</p> <ol style="list-style-type: none"> Add a programming card to the Door Control by presenting a card twice on power-up. The security wing must be removed first! Present this new programming card to enter Engineer mode. Present the programming card again to select “Default mode”. Present any other card once to default the Door Control. The process could take 20-30 seconds. The LED will flash once every second when it is complete



Phase 3 - Enrolling Door Controls

Step	Description
2.	<p>The controller is now ready to allow Door Controls to enroll onto the Network – Go to the ‘Controllers’ tab and Click on the ‘Wireless Network’ and then click the “Allow Doors to Join” start the controller scanning for new doors that do not already have an address – only DoorControls without an address can be enrolled.</p>
	<p>Note: For Wired 485 Door Controls, right click on the Controller on the right hand side of the application and select ‘Manually Assign Address’ from the drop down menu. Once all new Door Controls are found by the Controller they will all ‘beep’ with the number of the next available address/door position on the Controller. e.g. if door 2 is the next available address then all Door Controls will beep at the same time with 2 beeps. This is basically saying that any door can be assigned to this address – it’s up to the installer to decide which one. Also – you will notice that the Key back light of the keypad Door Controls will be illuminated with the next available address as well. i.e. Key 2 will be illuminated for this example.</p>
3.	<p>Go to the Door control that you want to make door 2 on the network system (it should be beeping 2 times). Press any key on this keypad and the system will automatically assign this door control to door 2 address on the system. Present a card if the Door Control is Prox Only.</p>
	<p>Note: All other Door Controls will now start beeping with the next available address i.e. ‘3 beeps’ (address 3) in this instance and so on every time you enroll a new Door Control. The Key back light will also correspond to each address as the system fills up.</p>



Phase 3 - Enrolling Door Controls

Step	Description
4.	Once all Door Controls are enrolled onto the network – go back to the Controller application and click the 'Secure Network' button –this safeguards the systems –if you select another tab on the application this will happen automatically.
5.	<p>Select each Door on the application and configure individual settings such as Door Name, Timed Actions, Relay Times, Ajar Times, Door Option and Alarm Options etc.</p> <p>IMPORTANT: A timezone must be selected in 'Timed Actions' for one of the options: Card and PIN, Any Card, Card or PIN , or PIN only. If all of these are set to 'inactive' then access will be denied for all cards and PINs on that Door Control.</p> <p>Example: To Enable PIN codes only on a Wi-PIN&Prox: Set the Timed Action "Card or PIN" to "Inactive" and set the Timed Action "PIN Only" to "All day,Every Day". This will grant access for PIN codes and deny access for cards and fobs.</p>



Phase 4 - Configuring Users

Step	Description
1.	Enable a User by ticking the 'Enabled' box for each User
2.	Assign a Name to the User
3.	Assign a UserGroup from the drop-down menu. The Usergroup will determine the access levels for this User. Refer to section on page 20 'Configuring Access Levels' for information on User Groups.
4.	Assign a Card , PIN number and enroll FingerPrints for the User. Refer to section FingerPrint Enrolment on page 22 Click 'save' to transmit these changes to the Controller.



Phase 5 - Configuring Access Levels

Step	Description
	Access Levels are controlled by creating UserGroups and assigning the UserGroup to a User as described in section 'Configuring Users'.
1.	UserGroups are created by combining pairs of DoorGroups with Timezones. Each UserGroup can have up to 6 pairs of DoorGroups and Timezones. Select DoorGroups and Timezones from the drop-down menus to add to the current UserGroup.
2.	Timezones are the periods of time for each day of the week that access will be granted. Select times and tick the days of the week this time is valid. 4 time periods can be created for each timezone. Select 'Holiday Access' to grant access for holiday periods. Double click on the 'Holiday Access' to add days to the holiday periods. Use the calendar to select these days.
3.	DoorGroups are created by grouping doors together. e.g. all the entry and exit doors could be grouped together as 'Perimeter Doors'. Select a Door from the 'All available Doors' window and drag it to the 'Doors in Current Door Group' to add it to the Door Group. Repeat for adding each door.

Phase 6 - Downloading Configuration

Step	Description
	After all users, access levels and door control settings have been finalised, a full download to the controller should be carried out.
1.	Go to the 'Settings' tab and click on 'Download Configuration'. A pop-up window will appear, tracking the status of the download. All settings will be downloaded to the Controller and Door Controls.



Enrolling User Fingerprints

Step	Description
	Note: Make sure the USB Fingerprint reader is attached to the PC
1.	On the Users Tab , Select a User for fingerprint enrollment
2.	Click on the 'Fingerprints' button.
3.	Click on '+' button to begin and place finger on the enrolment reader. An image of the fingerprint will appear on the screen. Ensure that the image quality is good and a value of at least 90% is achieved. Refer to section 'Finger Placement' for correct finger placement and example of good quality image. Repeat this process if this is not achieved on first attempt.
4.	Click 'Save' using a good quality template only. Poor Quality templates can lead to false rejections later when trying to gain access .



Correct Finger Placement

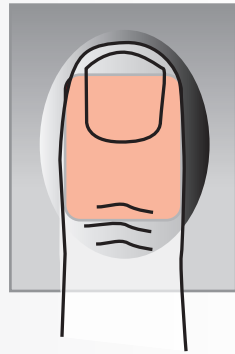
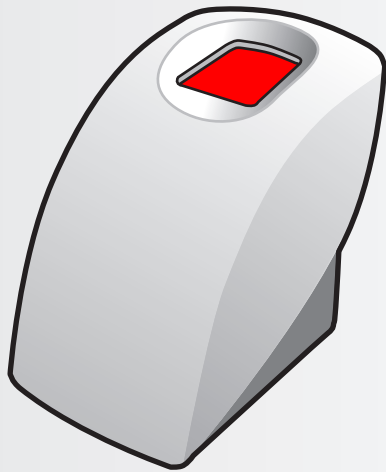

Good Quality Image

Note: Ensure that the core of finger is centered on the sensor window during the enrollment process. This will increase the quality of the fingerprint template. Ensure a value of at least 90% is achieved.

Note: Good Quality image, Fingerprint core is center of sensor window

Note: The System does not store the finger print. It uses an algorithm to generate a binary representation using sample points from the fingerprint. It uses this information to then validate each users fingerprint.



Incorrect Finger Placement

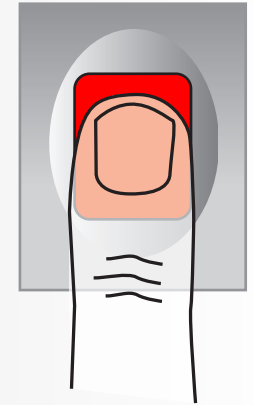

Note: Incorrect placement : finger does not fully cover the sensor window.



Poor Quality Image

Note: Poor Quality image, No Fingerprint core on sensor window.

This can result in poor template quality that can lead to false rejection issues later when the user is trying to gain access.





Correct Finger Placement

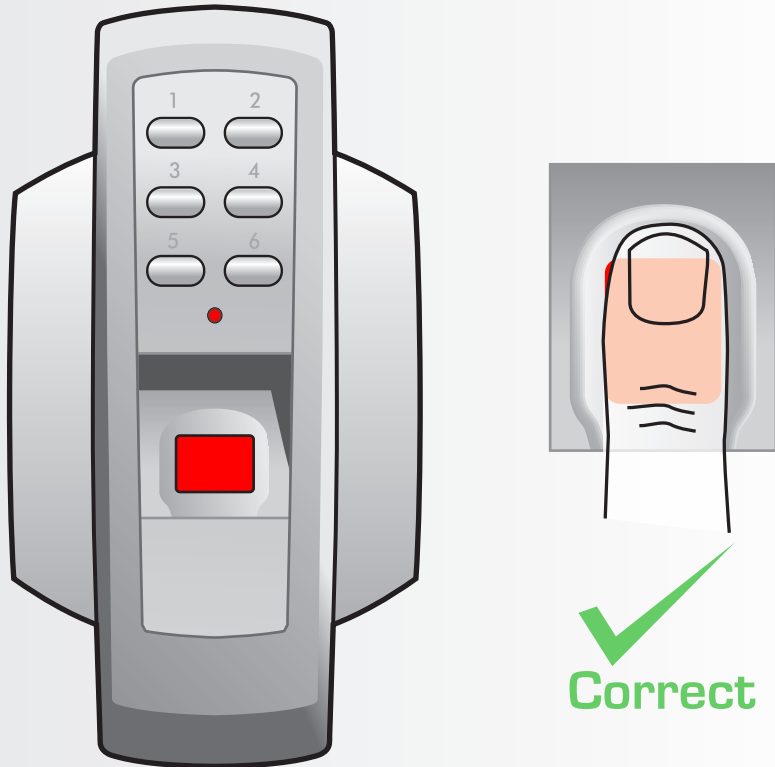

Note: Ensure that the finger is centered and placed flat to the surface and fully covers the sensor window.

Note: Finger must remain on the sensor window until the door control acknowledges that the finger has been scanned by sounding a beep and turning off the red light. This will take approximately 1 second.



Incorrect Finger Placement

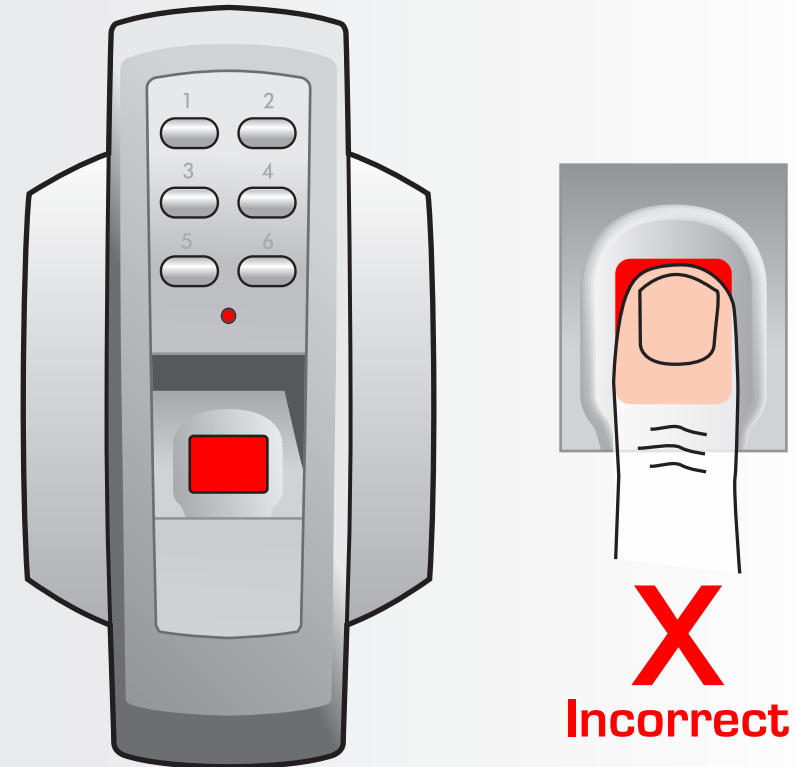

Note: Incorrect placement : finger does not fully cover the sensor window. The door control will not respond and the red light will not turn off if the sensor window is not fully covered by the finger.



Ctrl	Door No.	Door Type	Door Location Name	Walk Test
1	1			
	2			
	3			
	4			
	5			
	6			
	7			
	8			
	9			
	10			
	11			
	12			
	13			
	14			
	15			
	16			
	17			
	18			
	19			
	20			
2	1			
	2			
	3			
	4			
	5			
	6			
	7			
	8			
	9			
	10			



Ctrl	Door No.	Door Type	Door Location Name	Walk Test
2	11			
	12			
	13			
	14			
	15			
	16			
	17			
	18			
	19			
	20			
3	1			
	2			
	3			
	4			
	5			
	6			
	7			
	8			
	9			
	10			
	11			
	12			
	13			
	14			
	15			
	16			
	17			
	18			
	19			
	20			