

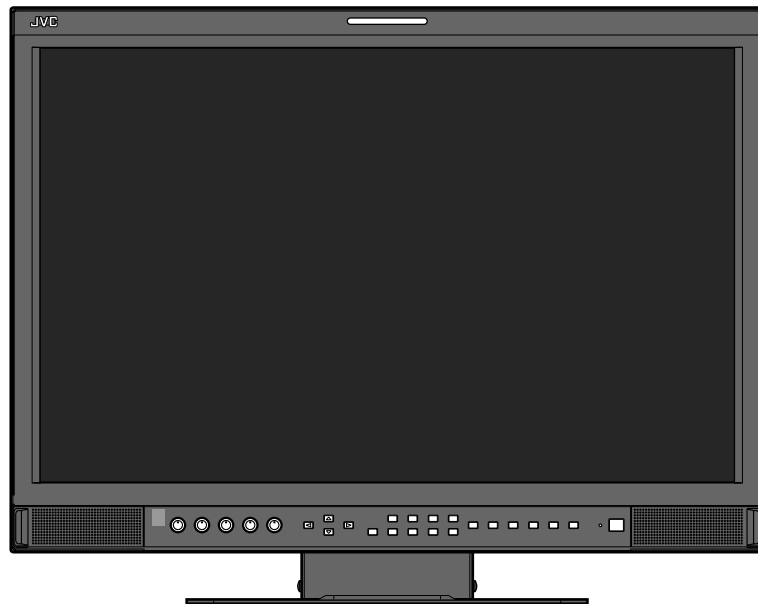

DT-V24L1D DT-V24L1 DT-V20L1D DT-V20L1

INSTRUCTIONS

MULTI FORMAT LCD MONITOR



The illustration of the monitor is of DT-V24L1D.

Table of Contents

Safety Precautions	2
IMPORTANT SAFEGUARDS	2
Maintenance	3
Installation	4
Using the monitor on the stand	4
Installing the monitor in the rack.....	5
Daily Operations / Connections	6
Front panel	6
Rear panel.....	8
Available signals	9
Menu Configuration—MAIN MENU	10
Menu Configuration—SET-UP MENU	12
External Control	14
About the external control	14
Using the MAKE/TRIGGER system	14
Using the serial communication	15
Troubleshooting	16
Self-check program	16
Specifications	17
General.....	17
Input/output terminals.....	17
Dimensions.....	18

Safety Precautions

WARNING: TO REDUCE RISK OF FIRE OR ELECTRIC SHOCK, DO NOT EXPOSE THIS APPARATUS TO RAIN OR MOISTURE. NO OBJECTS FILLED WITH LIQUIDS, SUCH AS VASES, SHALL BE PLACED ON THE APPARATUS.

IMPORTANT SAFEGUARDS

Electrical energy can perform many useful functions. This unit has been engineered and manufactured to assure your personal safety. But **IMPROPER USE CAN RESULT IN POTENTIAL ELECTRIC SHOCK OR FIRE.** In order not to defeat the safeguards incorporated into this product, observe the following basic rules for its installation, use, and service. Please read these "IMPORTANT SAFEGUARDS" carefully before use.

- All the safety and operating instructions should be read before the product is operated.
- The safety and operating instructions should be retained for future reference.
- All warnings on the product and in the operating instructions should be adhered to.
- All operating instructions should be followed.

POWER CONNECTION

The power supply voltage rating of this product is AC 120 V (For U.S.A. and Canada) and AC 220 – 240 V (For European countries, Asian countries, and United Kingdom).

The power cord attached conforms to the following power supply voltage and countries. Use only the power cord designated to ensure safety and EMC regulations of each country.

For U.S.A. and Canada: AC 120 V

For European and Asian countries:
AC 220 – 240 V

For United Kingdom: AC 220 – 240 V



This plug will fit only into a grounded power outlet. If you are unable to insert the plug into the outlet, contact your electrician to install the proper outlet. Do not defeat the safety purpose of the grounded plug.

- This product should be operated only with the type of power source indicated on the label. If you are not sure of the type of power supply of your home, consult your product dealer or local electric power company.

Warning:

- Do not use the same power cord for AC 120 V as for AC 220 – 240 V. Doing so may cause malfunction, electric shock or fire.

Note for United Kingdom power cord only

The plug of United Kingdom power cord has a built-in fuse. When replacing the fuse, be sure to use only a correctly rated approved type, re-fit the fuse cover. (Consult your dealer or qualified personnel.)

How to replace the fuse

Open the fuse compartment with the blade screwdriver, and replace the fuse.

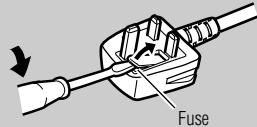

U.S.A. only

FCC NOTICE

CAUTION: Changes or modifications not approved by JVC could void the user's authority to operate the equipment.

NOTE: This equipment has been tested and found to comply with the limits for a Class A digital device, pursuant to Part 15 of the FCC Rules. These limits are designed to provide reasonable protection against harmful interference when the equipment is operated in a commercial environment. This equipment generates, uses, and can radiate radio frequency energy and, if not installed and used in accordance with the instruction manual, may cause harmful interference to radio communications. Operation of this equipment in a residential area is likely to cause harmful interference in which case the user will be required to correct the interference at his own expense.

Under the following conditions,

1. Turn off the power.
 2. Unplug this product from the wall outlet.
 3. Refer service to qualified service personnel.
- a) When the product emits smoke or unusual smell.
 - b) When the product exhibits a distinct change in performance—for example, no picture or no sound.
 - c) If liquid has been spilled, or objects have fallen on the product.
 - d) If the product has been exposed to rain or water.
 - e) If the product has been dropped or damaged in any way.
 - f) When the power supply cord or plug is damaged.

- Make enough room for inserting or removing the power plug. Place the product as close to an AC outlet as possible. The main power supply for the product is controlled by inserting or removing the power plug.
- When you install the product in a place where you cannot easily insert or remove the power plug from an AC outlet, do not use the provided power cord holder, and insert or remove the power cord from the AC inlet on the product.
- When the product is left unattended and unused for a long period of time, unplug it from the wall outlet and disconnect the cable system.
- Do not overload wall outlets, extension cords, or convenience receptacles on other equipment as this can result in a risk of fire or electric shock.
- Use only the accessory cord designed for this product to prevent shock.

- Do not install this product in the following places:

- in a damp or dusty room
- where the product is exposed to soot or steam, such as near the cooking counter or a humidifier
- near heat sources
- where condensation easily occurs, such as near the window

- Do not place this product on an unstable cart, stand, or table. The product may fall, causing serious injury to a child or adult, and serious damage to the product.

The product should be mounted according to the manufacturer's instructions, and should use a mount recommended by the manufacturer.

- Do not use this product near water.
 - Be sure to install the product in the place where proper temperature and humidity are kept (Ⓔ "Operating conditions" on page 17).
- This product becomes hot during its use. Take enough care when handling the product.

Do not attempt to service this product yourself, as opening or removing covers may expose you to dangerous voltages and other hazards. Refer all service to qualified service personnel.

• Slots and openings in the cabinet are provided for ventilation. These ensure reliable operation of the product and protect it from overheating. These openings must not be blocked or covered.

- Never push objects of any kind into this product through openings as they may touch dangerous voltage points or short-circuit the parts, which could result in a fire or electric shock.
- Never spill liquid of any kind on the product.
- Do not put heavy objects on the product.
- Do not step on or hang on the product.

Do not use the product for a long time if the sound is distorted.

- Before connecting other products such as VCR's and personal computers, you should turn off the power of this product for protection against electric shock.
- Do not use attachments not recommended by the manufacturer as they may be hazardous.
- **When replacement parts are required**, be sure the service technician has used replacement parts specified by the manufacturer or equivalents. Unauthorized substitutions may result in fire, electric shock, or other hazards.
- **Upon completion of any service or repairs to this product**, ask the service technician to perform safety checks to determine that the product is in proper operating condition.

European Union only

Dear Customer,

This apparatus is in conformance with the valid European directives and standards regarding electromagnetic compatibility and electrical safety.

European representative of Victor Company of Japan, Limited is:
 JVC Technology Centre Europe GmbH
 Postfach 10 05 52
 61145 Friedberg
 Germany

Information for Users on Disposal of Old Equipment



[European Union]

This symbol indicates that the electrical and electronic equipment should not be disposed as general household waste at its end-of-life. Instead, the product should be handed over to the applicable collection point for the recycling of electrical and electronic equipment for proper treatment, recovery and recycling in accordance with your national legislation.

By disposing of this product correctly, you will help to conserve natural resources and will help prevent potential negative effects on the environment and human health which could otherwise be caused by inappropriate waste handling of this product. For more information about collection point and recycling of this product, please contact your local municipal office, your household waste disposal service or the shop where you purchased the product.

Penalties may be applicable for incorrect disposal of this waste, in accordance with national legislation.

(Business users)

If you wish to dispose of this product, please visit our web page www.jvc-europe.com to obtain information about the take-back of the product.

[Other Countries outside the European Union]

If you wish to dispose of this product, please do so in accordance with applicable national legislation or other rules in your country for the treatment of old electrical and electronic equipment.

Attention:
 This symbol is only valid in the European Union.

European Union only

EMC Supplement

This equipment is in conformity with the provisions and protection requirements of the corresponding European Directives. This equipment is designed for professional video appliances and can be used in the following environments:

- Controlled EMC environment (for example purpose built broadcasting or recording studio), and rural outdoors environment (far away from railways, transmitters, overhead power lines, etc.)

In order to keep the best performance and ensure electromagnetic compatibility, we recommend to use cables not exceeding the following length:

Cable		Length
Power cord	(attached cable (H05VV-F 3 x 0.75 mm ²))	2.0 m
Video signal cable	(coaxial cable)	2.0 m
Audio signal cable	(shielded cable)	1.5 m
DVI cable	(shielded cable)	1.5 m
RS-232C cable	(shielded cable)	2.0 m
(A straight cable with a D-sub 9-pin connector)		
RS-485 cable	(twist pair cable)	2.0 m
(A straight LAN cable)		
REMOTE cable	(twist pair cable)	2.0 m
(A straight LAN cable)		

The inrush current of this apparatus is 5.428 ampere.

CAUTION

In case where the strong electromagnetic waves or magnetism are near the audio cable or the signal cable, the sound or the picture will contain noise. In such cases, please keep the cable away from the sources of the disturbance.

Maintenance

Unplug this product from the wall outlet before cleaning.

Screen

To avoid irreparable change in appearance of the screen such as uneven color, discoloration, scratches, be careful about the following:

- Do not paste or stick anything with any glues or adhesive tapes.
- Do not write anything on the screen.
- Do not strike the screen with a hard object.
- Avoid condensation on the screen.
- Do not wipe the screen with solvent such as alcohol, thinner, or benzine.
- Do not wipe the screen hard.

If the screen gets stained, wipe it with a soft dry cloth, a soft damp cloth, or a soft cloth soaked in water-diluted neutral detergent and wrung well.

Cabinet

To avoid the deterioration or damages of the cabinet such as its paint's peeling away, be careful about the following:

- Do not wipe the cabinet using solvent such as alcohol, thinner, or benzine.
- Do not expose the cabinet to any volatile substance such as insecticides.
- Do not remain any rubber or plastic in contact for a long time.
- Do not wipe the cabinet hard.

Wipe stains off the cabinet with a soft cloth. If the cabinet gets heavily stained, wipe it with a soft cloth soaked in water-diluted neutral detergent and wrung well, then wipe with a soft dry cloth.

Ventilation openings

- Use a vacuum cleaner to get rid of the dust around the intakes (all the openings). If a vacuum cleaner is not available, use a cloth and wipe it off. Leaving the dust around the intakes may prevent proper temperature control and cause damage to the product.

CAUTION

- Do not rest your arm on the monitor or lean against the monitor.
- Do not hold the LCD panel when installing the monitor.
- Make sure to install the monitor securely to prevent the monitor from falling over, which causes damage to the monitor or injury.

■ Using the monitor on the stand

You can place the monitor in the following two ways when using the monitor on the supplied stand.

You can tilt the monitor from about 6° upward to about 6° downward.

- When the monitor is not tilted (0°), the guidelines align as illustrated below.

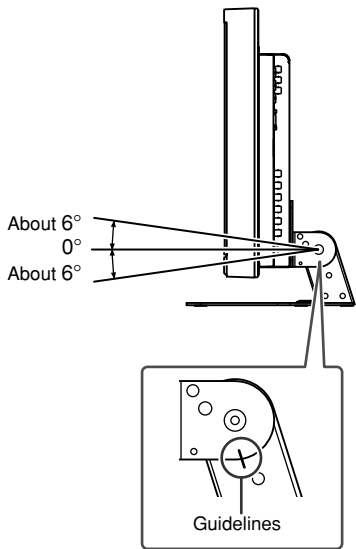

The illustration of the monitor is of DT-V24L1D.

CAUTION

- Be careful not to pinch your fingers in the gap between the monitor and the stand.
- When the stand plate is attached to the lower position of the stand body (see "To adjust the stand height" on page 5), you cannot tilt the monitor downward.

When the stand plate is attached to the higher position of the stand body (see "To adjust the stand height" on page 5), you can lift the stand up by about 148° and place the monitor as illustrated below.

- Remove the screws on the left and right sides of the stand (see the illustration below), then lift the stand up by about 148°. Make sure of attaching the removed screws after lifting up the stand.
- To place the monitor as illustrated on the left again, remove the screws on the left and right sides of the stand, return the monitor angle to 0°, then attach the removed screws.

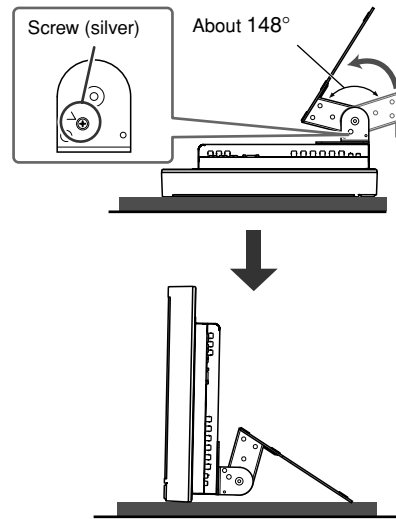

The illustrations of the monitor are of DT-V24L1D.

CAUTION

- When lifting up the stand, lay the monitor on a cloth with the LCD panel facing down to prevent the LCD panel being damaged.
- Be careful not to pinch your fingers in the moving parts.
- Make sure to lift the stand up until it stops (about 148°); otherwise the monitor may fall over.
- Place the monitor on a mat to avoid scratching the table surface.
- Do not place the monitor in this way when the stand plate is attached to the lower position of the stand body (see "To adjust the stand height" on page 5).

To detach the stand

CAUTION

- Lay the monitor on a cloth with the LCD panel facing down to prevent the LCD panel being damaged.

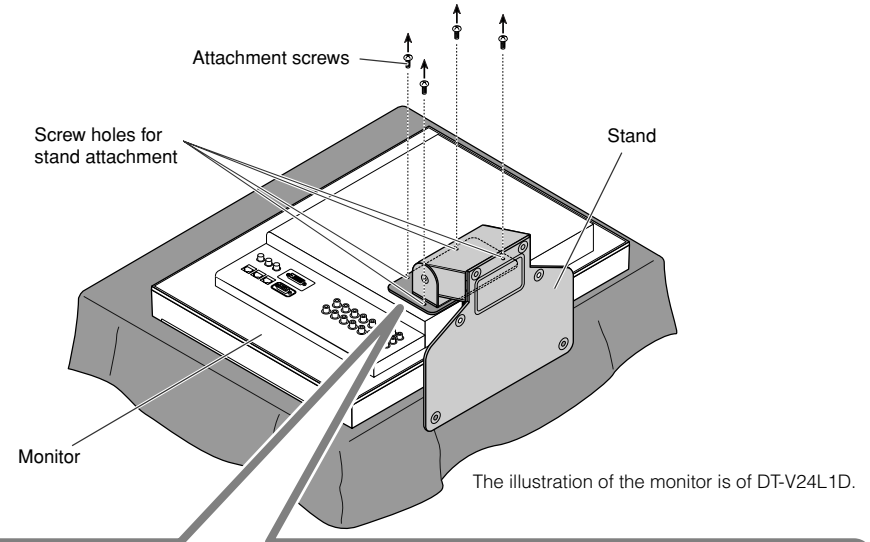

When installing the stand to the monitor, insert the guides of the stand into the guide holes on the monitor to place the stand on the correct position. Then fix the stand firmly with the attachment screws.

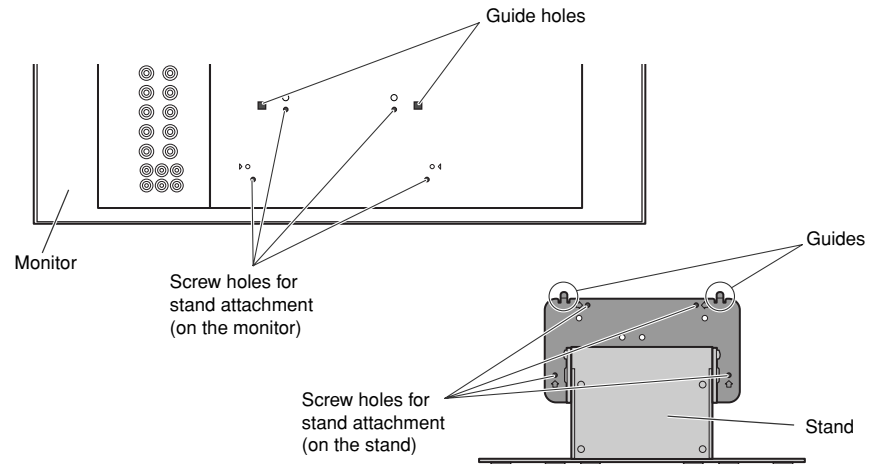

To adjust the stand height

You can select the stand height—higher position or lower position.

To change the stand height, change the position of the stand plate as illustrated below after detaching the stand from the monitor.

- For detaching the stand, see “To detach the stand” on page 4.

<Higher position>

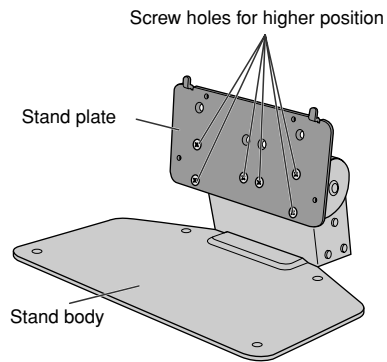

<Lower position>

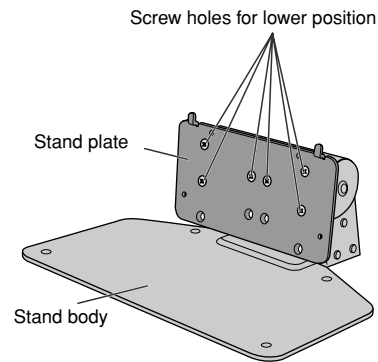

To prevent an accidental fall

Fix the stand to a table or floor with M5 screws (not supplied).

- Choose the screws of proper length corresponding to the thickness of the table or floor.

<Top side view>

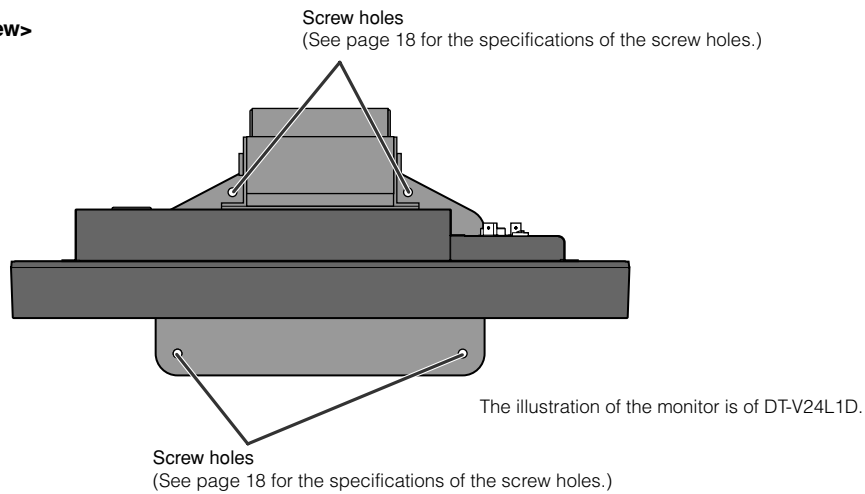

■ Installing the monitor in the rack (DT-V20L1D and DT-V20L1 only)

Use a JVC's RACK MOUNT ADAPTER (RK-C20L1; not supplied).

CAUTION

- Detach the stand first.
- Ask your dealer to install.

Front panel

DT-V24L1 and DT-V20L1 do not have 17, SDI 1 and SDI 2 buttons/lamps (18).

Tally lamp

This lamp is controlled by the tally function of MAKE/TRIG. terminal (see "FUNCTION SETTING" on page 12 and "External Control" on page 14).

NOTE

"NO EFFECT" is displayed when you press a button which is not available for the current input or signal format (the lamp lights even when the function does not actually work).

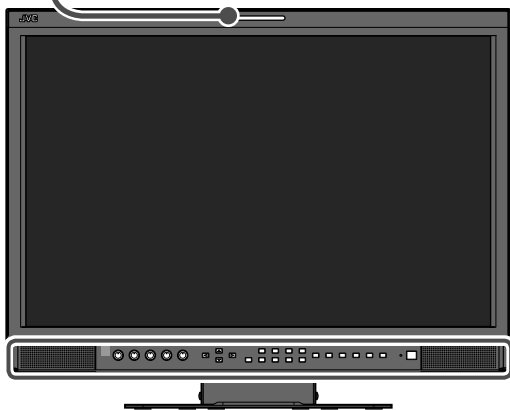

The illustration of the monitor is of DT-V24L1D.

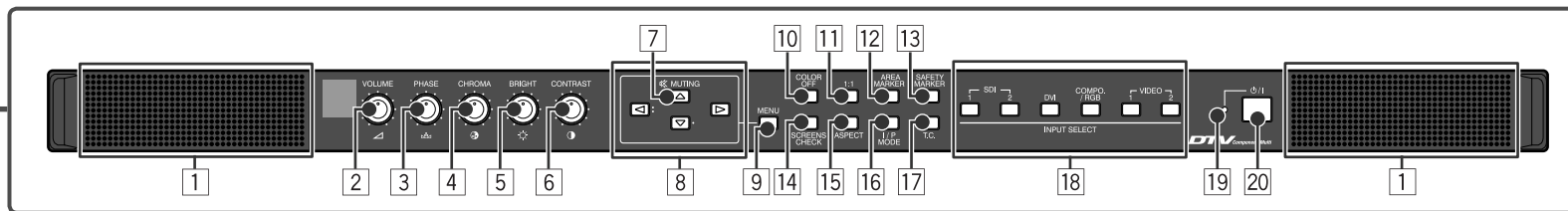

1 Speakers (stereo)

The speakers emit the same audio signal output from AUDIO ASSIGN (MONITOR OUT) terminals. See "8 AUDIO ASSIGN (MONITOR OUT) terminals" on page 8

2 VOLUME adjustment knob

Adjusts the speaker volume.

3 PHASE adjustment knob

Adjusts the picture hue.

4 CHROMA adjustment knob

Adjusts the picture color density.

5 BRIGHT adjustment knob

Adjusts the picture brightness.

6 CONTRAST adjustment knob

Adjusts the picture contrast.

7 MUTING button

Mutes the sound when a menu screen is not displayed.

- To cancel the function, press the button again or turn the VOLUME adjustment knob.

8 Menu select buttons (</>/</>/</>)

When a menu screen is displayed

- Selects or adjusts menu items. See "Menu Operations" on page 7

When no menu screen is displayed

- Selects the audio channels of EMBEDDED AUDIO (DT-V24L1D and DT-V20L1D only). See "Audio Channel Selection" on page 7

To display the set-up menu

- Press </> button while pressing </> button. See "Menu Operations" on page 7

9 MENU button

Displays the main menu.

See "Menu Operations" on page 7

10 COLOR OFF button/lamp

Displays only the luminance signal.

11 1:1 button/lamp

Displays the picture in the original resolution of the input signal.

NOTE

- This function does not work when the input video signal has higher resolution than the resolution of the panel (DT-V20L1D and DT-V20L1 only).
- The aspect ratio of the picture may change depending on the input signal.

12 AREA MARKER button/lamp

Activates/deactivates the settings of "MARKER SELECT," "ASPECT SELECT," "R-MARKER SELECT" and "R-ASPECT SELECT" in "AREA MARKER" (see page 10).

NOTE

- This function works when the picture is displayed in 16:9 aspect ratio.
- The functions do not work when "MARKER SELECT" or "R-MARKER SELECT" is set to "OFF" in "AREA MARKER."

13 SAFETY MARKER button/lamp

Activates/deactivates the settings of "ASPECT SELECT," "R-ASPECT SELECT," "SAFETY MARKER" and "R-SAFETY MARKER" in "AREA MARKER" (see 10 page).

NOTE

- This function does not work when displaying the picture in the 1:1 mode.
- The functions do not work when "SAFETY MARKER" or "R-SAFETY MARKER" is set to "OFF" in "AREA MARKER."

14 SCREENS CHECK button/lamp

Displays only the selected element (R, G, or B) of the video signal.

- Each time you press this button, the screen changes in the following order.



- The screen changes as above also when "SCR CHECK" is controlled with MAKE/TRIGGER system (see "External Control" on page 14).

15 ASPECT button/lamp

Changes the aspect ratio of the picture from 4:3 to 16:9.

- To return to 4:3, press the button again.
- Use this function when the picture of 16:9 aspect ratio is squeezed into 4:3 format signal.

NOTE

This function does not work when displaying the picture in the 1:1 mode.

16 I / P MODE button/lamp

Selects a proper mode corresponding to the input picture.

- Each time you press the button, the mode changes as follows.

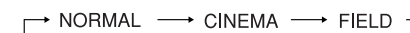

- The mode changes as above also when "I / P MODE" is controlled with MAKE/TRIGGER system (see "External Control" on page 14).

NOTE

Memorized for each input.

17 T.C. (time code) button/lamp

Displays the time data (time code) contained in the SDI signal.

18 INPUT SELECT buttons/lamps

Selects an input.

- SDI 1 : HD/SD SDI (IN 1) terminal
- SDI 2 : HD/SD SDI (IN 2) terminal
- DVI : DVI-D (HDCP) terminal
- COMPO. / RGB : COMPO. / RGB terminal
- VIDEO 1 : VIDEO (INPUT 1) terminal
- VIDEO 2 : VIDEO (INPUT 2) terminal
- The lamp for the selected input lights.

19 Power lamp

Unlit : The monitor is completely off (the AC plug is not connected).

Lights in Green : The monitor is on.

Lights in orange : The monitor is off (standby).

Flashes in orange : The monitor is in the suspend mode.

20 Standby button

Turns on and off (standby) the monitor.

NOTE

To disconnect the mains line completely, unplug the AC plug from the wall outlet.

Menu Operations

1 Display the menu.

To display the main menu

➔ Press MENU button.

To display the set-up menu

➔ Press ◀ button while pressing ▽ button.

When the main menu is displayed

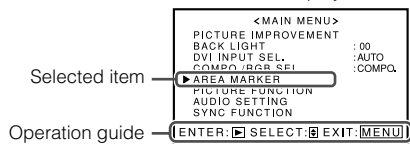

When the set-up menu is displayed

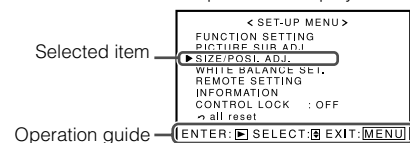

2 Press △ ▽ buttons to select an item, then press ▶ button.

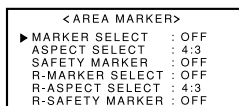

Ex.: When "AREA MARKER" is selected

3 Press △ ▽ buttons to select an item, then press ◀ ▶ buttons to make adjustments.

4 Press MENU button to return to the previous menu.

- Pressing the button again finishes the menu operation.

NOTE

For some items, adjustments will be made by pressing ◀ ▶ in step 2.

Audio Channel Selection (DT-V24L1D and DT-V20L1D only)

Select audio channels of EMBEDDED AUDIO signals to output from the speakers (L/R) and MONITOR OUT (L/R) terminals.

1 Press ◀ or ▶ button to display the screen for audio channel selection.

You cannot display this screen when displaying a menu screen.

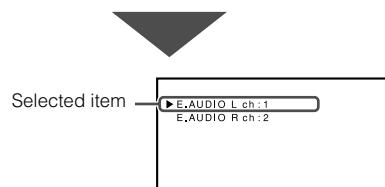

2 Press △ ▽ buttons to select the left (L) or right (R).

3 Press ◀ ▶ buttons to select an audio channel.

NOTE

- You can select channels from 12 audio channels.
- You have to choose a group of selectable audio channels before the channel selection (see "E.AUDIO GROUP" on page 11).

4 Press MENU button to finish the audio channel selection.

About the Status Display

The monitor displays the status information below depending on the settings of the menu and buttons at the top of the screen.

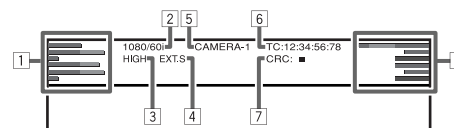

1 Audio level meter *

- Not displayed when no EMBEDDED AUDIO signal is input or "LEVEL METER ch" is set to "OFF" (see "AUDIO SETTING" on page 11).

2 Signal format

- "NO SYNC" is displayed when no video signal is input.
- "Out of range" is displayed for a noncompliant video signal input. When "COLOR SYSTEM" is set to "AUTO" (see "PICTURE FUNCTION" on page 11) and the noncompliant video signal is a composite one, "OTHERS" is displayed.

3 Setting of "COLOR TEMP."

- "WHITE BALANCE SET." on page 12
- "*" is displayed at the end of the indication when "HIGH" or "LOW" is selected in "COLOR TEMP" and its drive levels or cutoff points are adjusted.

4 Displayed when "SYNC INPUT SEL." is set to "EXT." (external synchronization)

- "SYNC FUNCTION" on page 11

5 Source name entered in "CHARACTER SET."

- "INFORMATION" on page 13
- Displayed when "MONITOR NAME" is set to "ON" (see "INFORMATION" on page 13).
- Displayed in large letters when "STATUS DISPLAY" is set to "OFF" or "AUTO" (see "INFORMATION" on page 13).

6 Time code *

- "17" T.C. (time code) button/lamp" on page 6
- When the input signal includes no time code, "TC:--:--:--:--" is displayed.

7 CRC error indication *

- "CRC ERROR" in "INFORMATION" on page 13
- A red square is displayed when an error occurs.

If you press INPUT SELECT button of the current input, the information below [2] - [4] and [8] is displayed in large letters for about three seconds. Then the status information on the left column [1] - [7] is displayed.

When "STATUS DISPLAY" is set to "AUTO" or "ALWAYS", the information below is also displayed in the cases below (see "INFORMATION" on page 13).

- When you change the input
- When the signal condition of the current input changes
- When turn on the monitor

8 Setting of "COMPO./RGB SEL." or the signal form of DVI input

- "COMPO./RGB SEL." or "DVI INPUT SEL." on page 10

NOTE

- When "STATUS DISPLAY" is set to "OFF" or "AUTO" (see "INFORMATION" on page 13), [2] - [4] are not displayed at the top of the screen.
- While displaying any of the status indications except [6] at the top of the screen, the picture is displayed below the status display area.

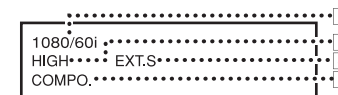

* DT-V24L1D and DT-V20L1D only

Rear panel

DT-V24L1 and DT-V20L1 do not have 9 and 10.

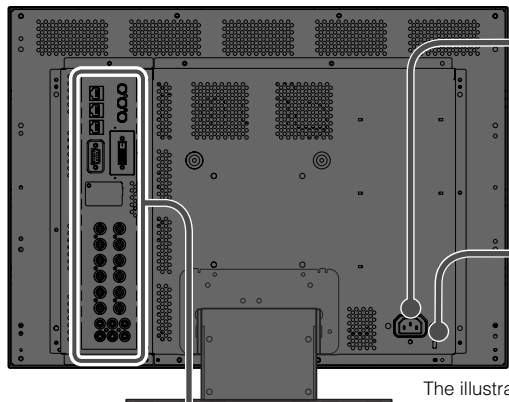

AC inlet
Power input connector. Connect the provided AC power cord to an AC outlet.
• Attach the provided power cord holder to prevent accidental disconnection of the AC power cord (see the right).

Security slot
Install a security wire to this slot.

The illustration of the monitor is of DT-V24L1D.

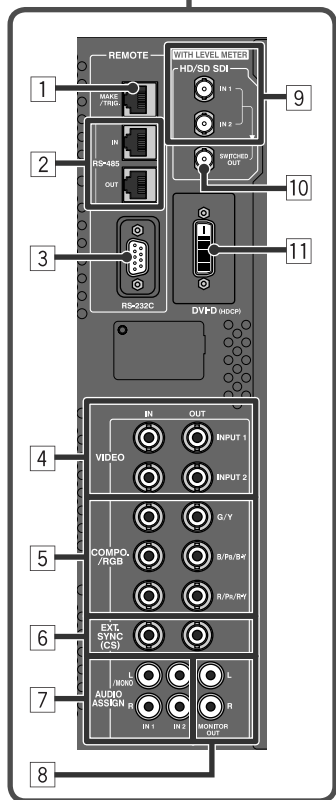

- 1 **REMOTE (MAKE/TRIG.) terminal (RJ-45)**
Terminal for controlling the monitor by an external control.
• “External Control” on page 14
 - 2 **REMOTE (RS-485) terminals (RJ-45)**
Terminals for controlling the monitor by an external control.
• “External Control” on page 14
 - 3 **REMOTE (RS-232C) terminal (D-sub 9-pin)**
Terminal for controlling the monitor by an external control.
• “External Control” on page 14
 - 4 **VIDEO (INPUT 1, INPUT 2) terminals (BNC)**
Input (IN) and output (OUT) terminals for the composite signals.
 - 5 **COMPO./RGB (G/Y, B/Pb/B-Y, R/Pr/R-Y) terminals (BNC)**
Input (IN) and output (OUT) terminals for the analog component (color difference) or analog RGB signals.
• Select the signal type in “COMPO./RGB SEL.” corresponding to the type of the input signal (see page 10).
 - 6 **EXT.SYNC (CS) terminals (BNC)**
Input (IN) and output (OUT) terminals for the external composite sync (Cs) signals.
• To use these terminals, set “SYNC INPUT SEL.” to “EXT.”
• “SYNC FUNCTION” on page 11
- NOTE**
- The terminals are for all VIDEO (INPUT 1), VIDEO (INPUT 2) and COMPO./RGB.
 - When an external sync signal is input, external synchronization has priority over all VIDEO 1, VIDEO 2 and COMPO./RGB input.
 - The setting of “SYNC INPUT SEL.” is memorized for each input.

CAUTION

It is recommended not to use the power cord holder when installing the monitor in a monitor rack etc. where you cannot easily pull out the AC power cord from an AC outlet.

Attaching the Power Cord Holder

- The provided power cord holder prevents accidental disconnection of the AC power cord from the AC inlet.
- The power cord holder consists of two parts, a case and a cover.

- 1 **Attach the power cord holder case around the AC inlet on the rear of the monitor with two screws (provided).**

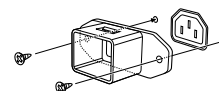

CAUTION

Use only the provided screws.

- 2 **Attach the power cord holder cover to the AC power cord.**

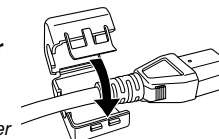

CAUTION

A different plug shape will result in the cover being attached to a different position.

- 3 **Plug in the AC power cord to the AC inlet, and attach the power cord holder cover to the case.**

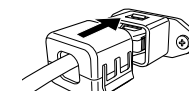

CAUTION

Make sure the plug will not be pulled out after the cover is attached.

NOTE

To detach the cover, release the tab.

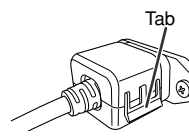

- 7 **AUDIO ASSIGN (IN 1, IN 2) terminals (pin jack)**

Input terminals for the analog audio signals.

- Select the video input to assign the audio signal in “AUDIO1 ASSIGN.” or “AUDIO2 ASSIGN.” (see “AUDIO SETTING” on page 11).

- 8 **AUDIO ASSIGN (MONITOR OUT) terminals (pin jack)**

Output terminals for the analog audio signal.

- The terminals output the audio signal through AUDIO ASSIGN (IN 1) or AUDIO ASSIGN (IN 2) terminals when you select the video input you have selected for “AUDIO1 ASSIGN.” or “AUDIO2 ASSIGN.” in “AUDIO SETTING” (see page 11).
- The EMBEDDED AUDIO signal is decoded into an analog signal, then emitted.

NOTE

- The signal is output from this terminal only when the monitor is on.
- The EMBEDDED AUDIO signal has priority over the audio signal input to AUDIO ASSIGN (IN 1) or AUDIO ASSIGN (IN 2) terminals when “SDI 1” or “SDI 2” is selected for “AUDIO1 ASSIGN.” or “AUDIO2 ASSIGN.” and the EMBEDDED AUDIO signal is input to HD/SD SDI (IN 1) or HD/SD SDI (IN 2) terminal.

- 9 **HD/SD SDI (IN 1, IN 2) terminals (BNC)**

Input terminals for the HD SDI and SD SDI signals. The terminals accept the following signals.

- SMPTE292M HD SDI signal
- SMPTE259M SD SDI signal
- EMBEDDED AUDIO signals* including up to 12 audio channels with the sampling frequency of 48 kHz.

NOTE

The types of signals coming through the IN 1 and IN 2 terminals are automatically recognized—HD SDI or SD SDI signal. Note, however, that input is not changed automatically.

- 10 **HD/SD SDI (SWITCHED OUT) terminal (BNC)**

Output terminal for the HD SDI and SD SDI signals.

- The SDI signal of the current input (SDI 1 or SDI 2) is re-locked and output.

NOTE

- When the input other than SDI 1 or SDI 2 is selected, the SDI signal of the input selected last time is re-locked and output from this terminal.
- The signal is output from this terminal only when the monitor is on.

- 11 **DVI-D (HDCP) terminal**

Input terminal for the DVI-D signal.

- Select the signal type in “DVI INPUT SEL.” corresponding to the type of the input signal (see page 10).

*Using the audio level meter (DT-V24L1D and DT-V20L1D only)

You can check the conditions of the current EMBEDDED AUDIO signals in the audio level meter. The setting for the level meter is selected in “LEVEL METER SETTING” (see “AUDIO SETTING” on page 11).

Available signals

The following signals are available for this monitor.

Video signals

No.	Signal name	Input terminal			
		VIDEO (INPUT1, INPUT2)	COMPO./RGB (Analog component/ analog RGB)	HD/SD SDI (IN 1, IN 2) ^{*1} (DT-V24L1D and DT-V20L1D only)	DVI-D (HDCP) (Digital component/digital RGB)
1	NTSC	√	—	—	—
2	PAL	√	—	—	—
3	SECAM	√	—	—	—
4	BW(50Hz/60Hz)	√	—	—	—
5	480/60i	—	√	√	—
6	576/50i	—	√	√	—
7	480/60p	—	√	—	√
8	576/50p	—	√	—	√
9	640*480/60p	—	—	—	√
10	720/60p	—	√	√	√
11	720/50p	—	√	√	√
12	720/30p	—	√	√	—
13	720/25p	—	√	√	—
14	720/24p	—	√	√	—
15	1080/60i	—	√	√	√
16	1035/60i	—	√ ^{*2}	√	—
17	1080/50i	—	√	√	√
18	1080/60p	—	—	—	√
19	1080/50p	—	—	—	√
20	1080/30p	—	√	√	√
21	1080/25p	—	√	√	√
22	1080/24p	—	√	√	√
23	1080/30psF	—	√ ^{*3}	√ ^{*3}	—
24	1080/24psF	—	√	√	—

√ : Acceptable

— : Not acceptable

^{*1} Compatible with EMBEDDED AUDIO

^{*2} Displays the picture as 1080/60i, and "1080/60i" is displayed in the status display (☞ page 7).

^{*3} "1080/60i" is displayed in the status display (☞ page 7).

Computer signals (preset)

DVI-D (HDCP) terminals

No.	Signal name	Screen resolution		Horizontal frequency (kHz)	Vertical frequency (Hz)	Scan system
		Horizontal	Vertical			
1	VGA60	640	480	31.5	59.9	Non-interlace
2	WVGA60	852	480	31.5	59.9	Non-interlace
3	SVGA60	800	600	37.9	60.3	Non-interlace
4	XGA60	1024	768	48.4	60.0	Non-interlace
5	WXGA (1280)	1280	768	47.8	60.0	Non-interlace
6	SXGA60	1280	1024	64.0	60.0	Non-interlace
7	SXGA+60	1400	1050	64.0	60.0	Non-interlace
8	SXGA+60*	1400	1050	65.2	60.0	Non-interlace
9	WSXGA+60	1680	1050	65.2	60.0	Non-interlace
10	UXGA60 ^{*4}	1600	1200	75.0	60.0	Non-interlace
11	WUXGA60 ^{*4}	1920	1200	74.0	59.9	Non-interlace

^{*4} For DT-V20L1D and DT-V20L1: When No. 10 or 11 signal is input, thin lines will become obscured because their signal resolution is higher than the screen resolution.

Specification of DVI-D (HDCP) terminal

Connect it to DVI-D output terminal on a personal computer.

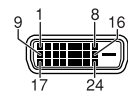

Pin No.	Input signal	Pin No.	Input signal	Pin No.	Input signal
1	T.M.D.S Data 2-	9	T.M.D.S Data 1-	17	T.M.D.S Data 0-
2	T.M.D.S Data 2+	10	T.M.D.S Data 1+	18	T.M.D.S Data 0+
3	T.M.D.S Data 2 shield	11	T.M.D.S Data 1 shield	19	T.M.D.S Data 0 shield
4	NC	12	NC	20	NC
5	NC	13	NC	21	NC
6	DDC Clock	14	+5 V Power	22	T.M.D.S Clock shield
7	DDC Data	15	GND	23	T.M.D.S Clock+
8	NC	16	Hot Plug Detect	24	T.M.D.S Clock-

Note for analog component/analog RGB signals

The monitor is compatible with G on sync, Y on sync and composite sync (Cs) signals. The monitor is not compatible with separate sync (HS/VS) signals.

Note for computer signals

- Non-preset signals may not be displayed normally even if its frequency is within the acceptable range.
- When a preset signal is input, the signal format is displayed on the screen. For other signals, the resolution is displayed.

Note for connections

- Before making any connections, turn off all the equipment.
- Use a cord whose plugs correctly match the terminals on this monitor and the equipment.
- Plugs should be firmly inserted; poor connections could cause noise.
- When unplugging a cord, be sure to grasp its plug and pull it out.
- DO NOT connect the power cord until all connections are completed.
- Refer also to the user manual of each piece of equipment.

Menu Configuration—MAIN MENU

For the operation procedure, see page 7.

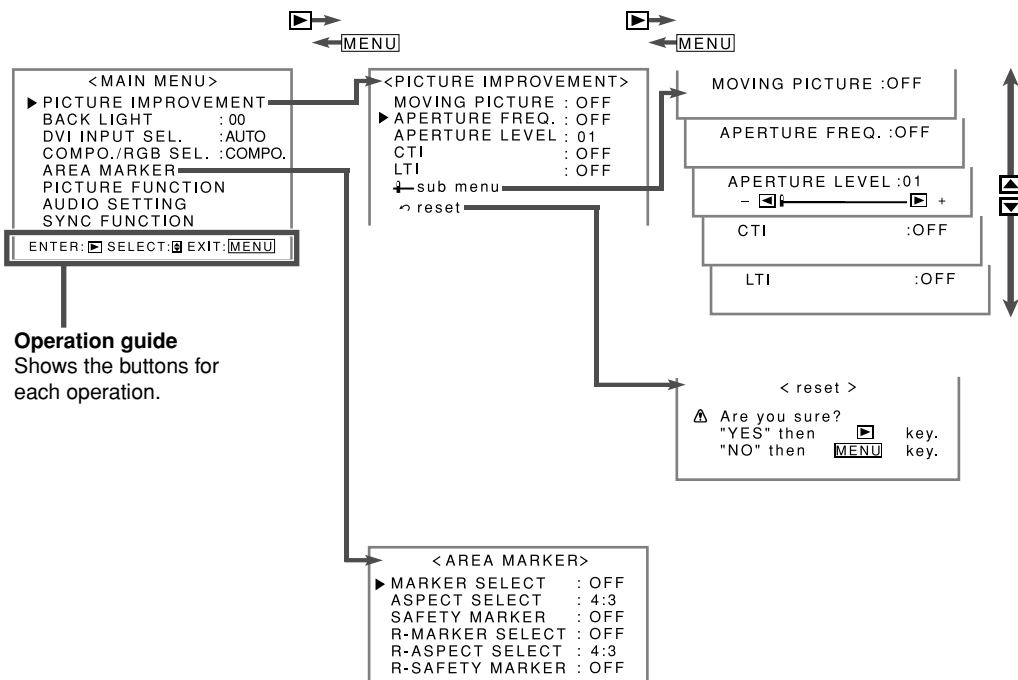

Operation guide
Shows the buttons for each operation.

- NOTE**
- The menu automatically disappears in about 30 seconds after the last menu operation.
 - Some items may not appear on the menu depending on the input or the input signal. These items are not available.

Technical information

Setting of “MARKER SELECT” and “R-MARKER SELECT”

The setting values and features are as follows.

- OFF** : “MARKER SELECT” and “R-MARKER SELECT” do not function.
- LINE** : Displays the area with an outline.
- HALF** : The area outside the specified aspect ratio of the screen is displayed as a 50% transparency.
- HALF+L** : The area of the specified aspect ratio of the screen is indicated by an outline, and the area outside of that is displayed as a 50% transparency.
- BLK.** : The area outside the specified aspect ratio of the screen is black. Only the portion of the picture within the designated area is displayed.
- BLK. +L** : The area of the specified aspect ratio of the screen is indicated by an outline, and the area outside of that becomes black so that only the area inside the line is displayed.

PICTURE IMPROVEMENT

Setting for the picture quality

Item	To do	Setting value
MOVING PICTURE *1	Reduce the lag of moving pictures which is peculiar to LCD.	OFF, ON
APERTURE FREQ. *2	Select the frequency of the luminance signal compensated in “APERTURE LEVEL.”	OFF, LOW, HIGH
APERTURE LEVEL *2	Compensate the frequency response of the luminance signal of the video signal.	01 – 10
CTI *2	Adjust the clearness of the outlines of the chrominance signal.	OFF, NORMAL, HARD
LTI *2	Adjust the clearness of the outlines of the luminance signal.	OFF, NORMAL, HARD
sub menu	Display the sub menu which enables you to adjust the items of “PICTURE IMPROVEMENT” while viewing the actual picture.	
reset	Restore the default settings for all the items in “PICTURE IMPROVEMENT.”	

BACK LIGHT Setting value: -20 – 00 – +20

Adjusts the brightness of the display.

DVI INPUT SEL. Setting value: AUTO, COMPO. (component), RGB

Selects the signal type you want to use for DVI-D (HDCP) terminal.

NOTE

- DVI-D input of the monitor is compatible with HDCP.
- Select “COMPO.” or “RGB” when the signal is not recognized correctly with “AUTO.”

COMPO./RGB SEL. Setting value: COMPO. (component), RGB

Selects the signal type you want to use for COMPO./RGB terminals.

AREA MARKER *2

Setting for AREA MARKER functions

Item	To do	Setting value
MARKER SELECT	Select the style of AREA MARKER whose aspect ratio is selected in “ASPECT SELECT.”	☞ “Technical information”
ASPECT SELECT	Select the aspect ratio of AREA MARKER. You can display this AREA MARKER with AREA MARKER button on the front panel (☞ page 6) or by using external control (☞ page 14).	4:3, 14:9, 13:9, 2.35:1, 1.85:1, 1.66:1
SAFETY MARKER	Adjust the size of SAFETY AREA within the area marked with AREA MARKER. This AREA MARKER’s aspect ratio is selected in “ASPECT SELECT.”	OFF, 80% – 100%
R-MARKER SELECT	Select the style of AREA MARKER whose aspect ratio is selected in “R-ASPECT SELECT.”	☞ “Technical information”
R-ASPECT SELECT	Select the aspect ratio of AREA MARKER. You can display this AREA MARKER by using external control (☞ page 14).	4:3, 14:9, 13:9, 2.35:1, 1.85:1, 1.66:1
R-SAFETY MARKER	Adjust the size of SAFETY AREA within the area marked with AREA MARKER. This AREA MARKER’s aspect ratio is selected in “R-ASPECT SELECT.”	OFF, 80% – 100%

NOTE

- To set up non-“R-” items, press AREA MARKER or SAFETY MARKER button. An external control system should not be operated at this time.
- Using the external control, you can select either “R-” items or non-“R-” items to activate (☞ “External Control” on page 14).
- When a picture is displayed in 4:3 aspect ratio, SAFETY AREA for the 4:3 area is displayed.
- To display SAFETY AREA for the area of a picture displayed in 16:9 aspect ratio, set “MARKER SELECT” and “R-MARKER SELECT” to “OFF.”

*1 DT-V24L1D and DT-V24L1 only

*2 Memorized for each input.

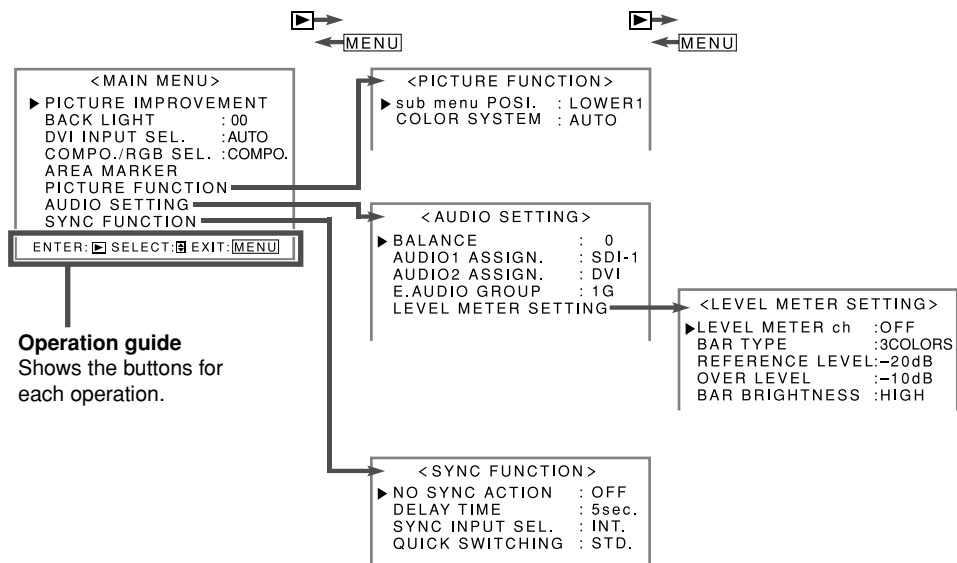

Operation guide
Shows the buttons for each operation.

- NOTE**
- The menu automatically disappears in about 30 seconds after the last menu operation.
 - Some items may not appear on the menu depending on the input or the input signal. These items are not available.

Technical information

Setting of "sub menu POSI."

The setting values and features are as follows.

- LOWER1** : Displays the current setting and adjustment bar at the lower part of the screen.
- UPPER1** : Displays the current setting and adjustment bar at the upper part of the screen.
- LOWER2** : Displays the current setting at the lower part of the screen.
- UPPER2** : Displays the current setting at the upper part of the screen.

NOTE

The adjustment bar is not displayed for some items.

Setting of "E.AUDIO GROUP"

The setting values and selectable audio channels of EMBEDDED AUDIO are as follows.

- 1G** : channel(s) 1/2/3/4/1+2/3+4/1 - 4 (1G)
- 2G** : channel(s) 5/6/7/8/5+6/7+8/5 - 8 (2G)
- 1-2G** : channel(s) 1/2/3/4/5/6/7/8/1+2/3+4/5+6/7+8/1 - 4 (1G)/5 - 8 (2G)/1 - 8 (1G+2G)
- 3G** : channel(s) 9/10/11/12/9+10/11+12/9 - 12 (3G)
- 1-3G** : channel(s) 1/2/3/4/5/6/7/8/9/10/11/12/1+2/3+4/5+6/7+8/9+10/11+12/1 - 4 (1G)/5 - 8 (2G)/9 - 12 (3G)/1 - 8 (1G+2G)/1 - 12 (1-3G)

Example of the level meter display—Level indication and audio channels

Ex.: When "LEVEL METER ch" is set to "12:78" and "BAR TYPE" is set to "3COLORS."

NOTE

- When "BAR TYPE" is set to "W.100," the standard input level set in the "REFERENCE LEVEL" is displayed with the line indication. The input level set in "OVER LEVEL" is not displayed.
- The audio channel bar with no signal input is displayed in white for "3COLORS," and in gray for "W.100."

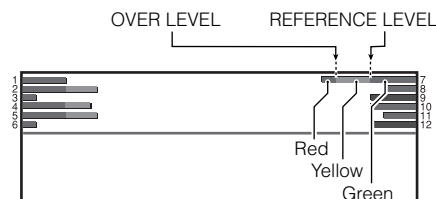

PICTURE FUNCTION

Setting for the screen display

Item	To do	Setting value
sub menu POSI.	Select the contents and displaying position of "sub menu."	☞ "Technical information"
COLOR SYSTEM	Select the color system. • If the picture is unstable with "AUTO," select the appropriate color system other than "AUTO."	AUTO, NTSC, PAL, SECAM

AUDIO SETTING

Setting for the audio input/output

Item	To do	Setting value
BALANCE	Adjust the balance between the right and left speakers.	L5 - L1, 0, R1 - R5
AUDIO1 ASSIGN.	Select the video input which the audio signal through AUDIO ASSIGN (IN 1) terminal is assigned to.	SDI-1*1, SDI-2*1, DVI, COMP/RGB, VIDEO-1, VIDEO-2
AUDIO2 ASSIGN.	Select the video input which the audio signal through AUDIO ASSIGN (IN 2) terminal is assigned to.	
E.AUDIO GROUP*1, 2	Select the audio channel group of the EMBEDDED AUDIO signals.	☞ "Technical information"
LEVEL METER SETTING*1, 2	Adjust the audio level meter display for the EMBEDDED AUDIO signals (☞ "Technical information").	
LEVEL METER ch	Select the audio channels used in the audio level meter display.	OFF, 12:78 (Displays the channels 1 - 6 at the top left of the screen and 7 - 12 at the top right.), 13:24 (Displays the odd channels at the top left of the screen and the even channels at the top right.)
BAR TYPE	Select the color of the audio level meter display.	3COLORS (3 colors to indicate variations in input levels), W.100 (white)
REFERENCE LEVEL	Select the standard input level.	-20dB, -18dB
OVER LEVEL	Select the input level's lower limit indicated in red for the "3COLORS" display.	-10dB, -8dB, -6dB, -4dB, -2dB
BAR BRIGHTNESS	Select the brightness of the audio level meter display.	HIGH, LOW

NOTE

- When selecting "BALANCE," the adjustment bar is displayed at the lower part of the screen.
- You cannot select the same input for both "AUDIO1 ASSIGN." and "AUDIO2 ASSIGN."

SYNC FUNCTION

Setting for the synchronization with signals

Item	To do	Setting value
NO SYNC ACTION	Select the screen status when no signal is being input.	OFF, SUSPEND (suspend mode), GRAY B.(gray screen)
DELAY TIME	Select the period until the screen status changes after signals stop coming in.	5sec., 20sec., 1min., 15min., 30min.
SYNC INPUT SEL.*2	Select the sync signal for the VIDEO and COMPO./RGB input.	INT., EXT.
QUICK SWITCHING	Select the quickness for switching the input.	STD., QUICK

*1 DT-V24L1D and DT-V20L1D only

*2 Memorized for each input.

Menu Configuration—SET-UP MENU

For the operation procedure, see page 7.

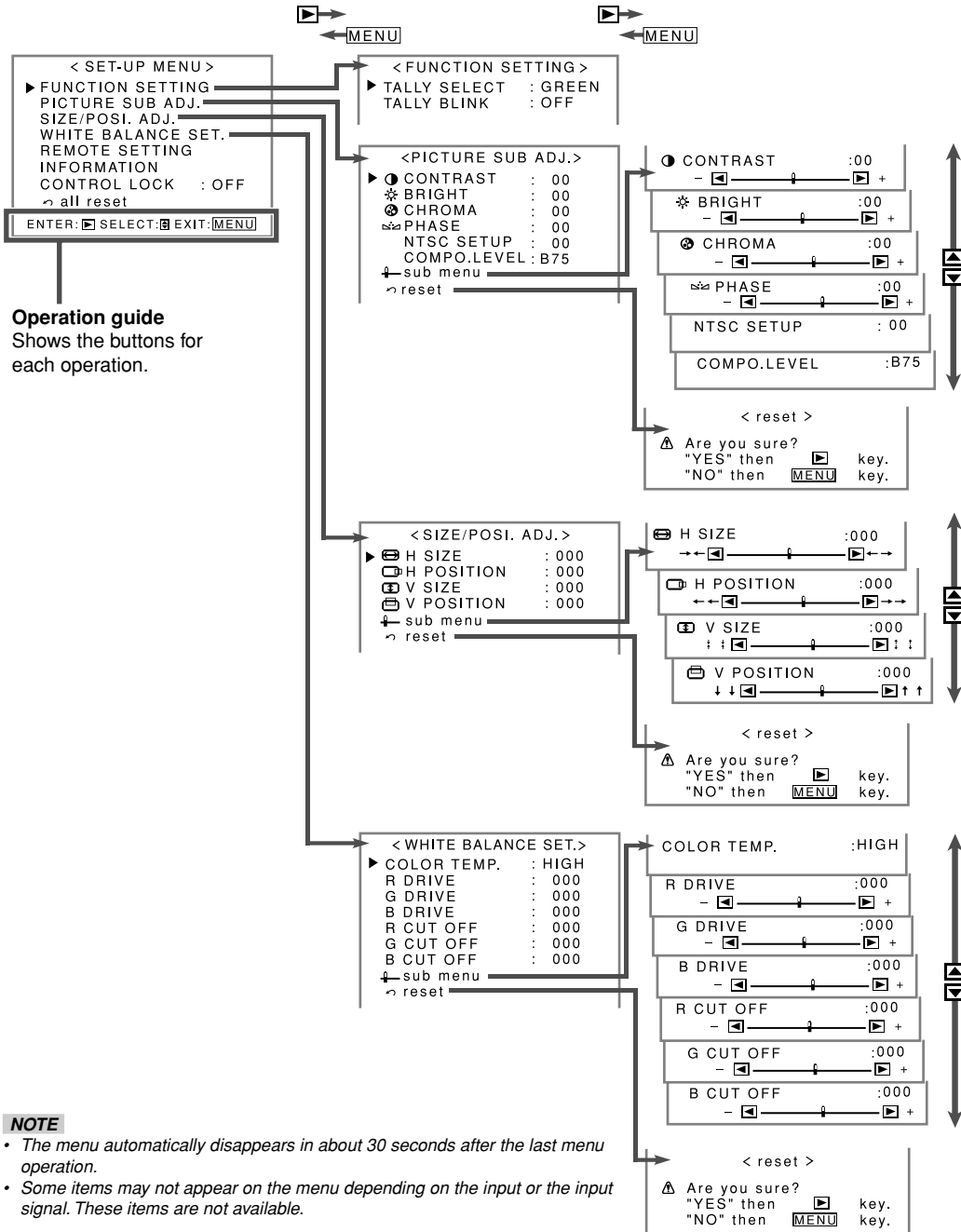

Operation guide
Shows the buttons for each operation.

- NOTE**
- The menu automatically disappears in about 30 seconds after the last menu operation.
 - Some items may not appear on the menu depending on the input or the input signal. These items are not available.

FUNCTION SETTING

Setting for the tally lamp

Item	To do	Setting value
TALLY SELECT	Select the color of the tally lamp on the upper front panel.	GREEN, RED
TALLY BLINK	Select the blinking time of the tally lamp till it gets lighting.	OFF, 5sec., 8sec.

NOTE

The tally lamp is controlled using MAKE/TRIG. terminal of REMOTE terminals (External Control on page 14).

PICTURE SUB ADJ.

Adjusts the standard level for the picture adjustment and selects the set-up level for the input video signal.

Item	To do	Setting value
CONTRAST *1	Adjust the standard level for the contrast adjusted with CONTRAST knob on the front panel.	-20 - 00 - +20
BRIGHT *1	Adjust the standard level for the brightness adjusted with BRIGHT knob on the front panel.	-20 - 00 - +20
CHROMA *1	Adjust the standard level for the chroma adjusted with CHROMA knob on the front panel.	-20 - 00 - +20
PHASE *1	Adjust the standard level for the phase adjusted with PHASE knob on the front panel.	-20 - 00 - +20
NTSC SETUP *1	Select the set-up level of the input NTSC signal.	00 (compliant with 0% set-up signal), 7.5 (compliant with 7.5% set-up signal)
COMPO. LEVEL	Select the level of the analog component signal.	SMPTE (compliant with M2VTR signals), B75 (compliant with BetacamVTR 7.5% set-up signal), B00 (compliant with BetacamVTR 0% set-up signal)
sub menu	Display the sub menu which enables you to adjust the items in "PICTURE SUB ADJ." while viewing the actual picture.	
reset	Restore the default settings for all the items in "PICTURE SUB ADJ."	

SIZE/POSI. ADJ.

Adjusts the size and position of the picture.

Item	To do	Setting value
H SIZE *2	Adjust the horizontal picture size.	
H POSITION *2	Adjust the horizontal picture position.	Varies depending on the other settings.
V SIZE *2	Adjust the vertical picture size.	
V POSITION *2	Adjust the vertical picture position.	
sub menu	Display the sub menu which enables you to adjust the items of "SIZE/POSI. ADJ." while viewing the actual picture.	
reset	Restore the default settings for all the items in "SIZE/POSI. ADJ."	

WHITE BALANCE SET.

Selects the color temperature and adjusts the drive level and cutoff point of each color (R/G/B).

Item	To do	Setting value
COLOR TEMP.	Select the color temperature.	HIGH(9300), LOW(6500), OTHER
R DRIVE, G DRIVE, B DRIVE *3	Adjust the drive level of each color (red, green, and blue).	MIN - 000 - MAX (in 256 grades)
R CUT OFF, G CUT OFF, B CUT OFF *3	Adjust the cutoff point of each color (red, green, and blue).	MIN - 000 - MAX (in 256 grades)
sub menu	Display the sub menu which enables you to adjust the items in "WHITE BALANCE SET." while viewing the actual picture.	
reset	Restore the default settings for the drive levels and cutoff points of the selected color temperature.	

*1 Memorized for each input.

*2 Memorized for each signal format.

*3 Memorized for each color temperature (HIGH, LOW, OTHER).

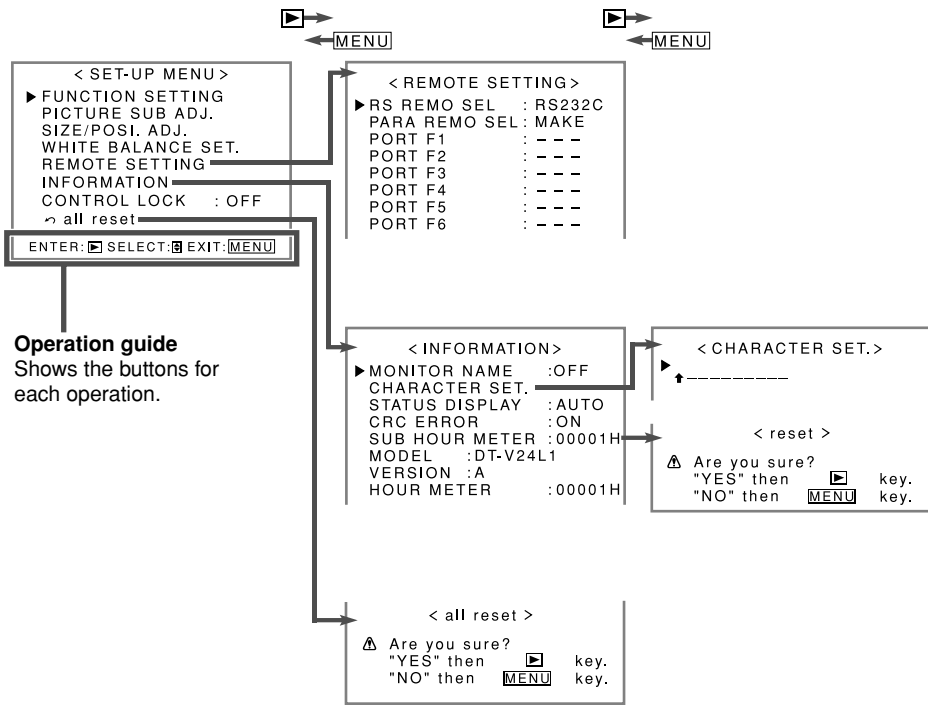

Operation guide
Shows the buttons for each operation.

- NOTE**
- The menu automatically disappears in about 30 seconds after the last menu operation.
 - Some items may not appear on the menu depending on the input or the input signal. These items are not available.

Technical information

Using "CHARACTER SET."

Enter a name for an input video source following the steps below.

1 Select "CHARACTER SET."



2 Press Δ ∇ buttons to select the first character.

- Each time you press Δ button, the character changes as follows. Press ∇ button to reverse the order.

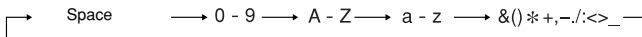

3 Press \triangleright button to move the arrow to the next.



4 Repeat steps 2 and 3 (10 characters at maximum).

5 Press MENU button to store the source name.

REMOTE SETTING (External Control on pages 14 and 15)

Setting for the external control

Item	To do	Setting value
RS REMO SEL	Select the input terminal used for an external control.	RS232C, RS485
PARA REMO SEL	Select the external control method for MAKE/TRIG. terminal.	MAKE, TRIGGER, SET
PORT F1, PORT F2, PORT F3, PORT F4, PORT F5, PORT F6	Assign the control functions to the pins of MAKE/TRIG. terminal (1 to 6) when selecting "SET" in "PARA REMO SEL."	COLOR OFF, ASPECT, A.MARKER, S.MARKER, TIME CODE *1, 1:1, SCR CHECK, I/P MODE, SDI 1 *1, SDI 2 *1, DVI, COMP/RGB, VIDEO 1, VIDEO 2, EXT.SYNC, TALLY, TALLY SEL, MONI. NAME, MUTING, MARK.SEL, L.METER *1, STATUS, --- (no function)

INFORMATION

Setting for the information display of the monitor

Item	To do	Setting value
MONITOR NAME	Choose if the name entered in "CHARACTER SET." is displayed on the screen (External Control "About the Status Display" on page 7).	OFF, ON
CHARACTER SET. *2	Enter an optional name for an input video source (10 characters at maximum).	External Control "Technical information"
STATUS DISPLAY	Choose if the information of the current input is displayed on the screen (External Control "About the Status Display" on page 7).	AUTO, OFF, ALWAYS
CRC ERROR *1	Choose if the CRC error indication for the input HD SDI signal is displayed on the screen (External Control "About the Status Display" on page 7).	OFF, ON
SUB HOUR METER	Display the total hours of use (unit: hour). You can reset this HOUR METER.	
MODEL	Display the model name of the monitor.	
VERSION	Display the version of the monitor.	
HOUR METER	Display the total hours of use (unit: hour). This item is used for maintenance of the monitor. You cannot reset this HOUR METER.	

CONTROL LOCK Setting value: OFF, ON

Turns on (or off) the control lock function to disable the buttons on the front panel.

NOTE

The following operations are available even though this function is activated.

- Turning on/off the monitor
- Displaying the set-up menu (by pressing \triangleleft button while pressing ∇ button) and turning "CONTROL LOCK" to "OFF"
- Operating the monitor by an external control

If you try other operations, "Control lock on!" appears on the screen.

all reset

Restores all the settings and adjustments of the monitor to the default.

NOTE

- "HOUR METER" and the settings done by using the adjustment knobs on the front panel will not be reset.
- After performing "all reset," the monitor is turned off then turned on automatically.

*1 DT-V24L1D and DT-V20L1D only

*2 Memorized for each input.

About the external control

This monitor has three external control terminals.

- **MAKE/TRIG. terminal** : The following external control systems are available.
 - (1) **MAKE (make contact system)**: Controls the function by short-circuiting the corresponding pin terminal to the GND pin terminal, or disconnecting (opening) it (☞ the right).
 - (2) **TRIGGER (trigger system)** : Controls the function by inputting the pulse signal instantaneously to the corresponding pin terminal (☞ the right).
- **RS-232C terminal** : Controls the monitor with RS-232C system. (☞ "Using the serial communication" on page 15)
- **RS-485 terminals** : Controls the monitor with RS-485 system. (☞ "Using the serial communication" on page 15)

Set the following items of "REMOTE SETTING" in set-up menu according to the external control terminal and control system you use (☞ page 13).

Control system		"RS REMO SEL" setting	"PARA REMO SEL" setting
MAKE		—	MAKE
TRIGGER		—	TRIGGER
Serial communication	RS-485	RS485*1	—
	RS-232C	RS232C*1	—

*1 On the monitor connected to the personal computer etc, select the terminal the equipment actually connected to. On the other monitors, select "RS485."

NOTE

- Control priority is as follows.
MAKE > TRIGGER, serial communication, and buttons on the monitor
- You can use the external control even when "CONTROL LOCK" is set to "ON" (☞ page 13).

<MAKE/TRIGGER system>

You can control the monitor by a personal computer or dedicated controller*2. For the details, see the right.

*2 The controller is not commercially available. Consult your dealer if you need it.

<Serial communication>

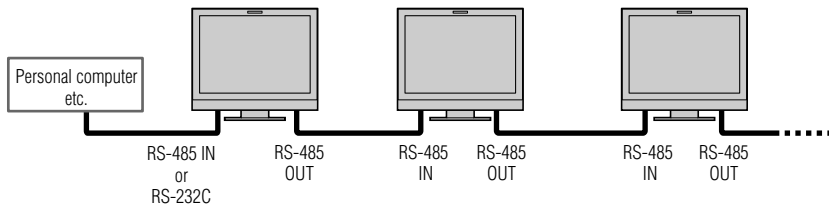

- See also page 15.

Using the MAKE/TRIGGER system

MAKE/TRIG. terminal is configured as follows. You can assign a function to each pin terminal in "REMOTE SETTING" (☞ "PORT F1" – "PORT F6" on page 13).

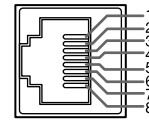

This is a female terminal.

Pin No.	Pin name	Pin No.	Pin name
1	PORT F1	5	PORT F5
2	PORT F2	6	PORT F6
3	PORT F3	7	External control*3
4	PORT F4	8	GND

*3 The external control (the 7th pin terminal) must be controlled by the MAKE (make contact) system.

To assign the functions to the pin terminals

For the operation procedure, see page 7.

- 1 Select "REMOTE SETTING" on the set-up menu.
- 2 Set "PARA REMO SEL" to "SET."
- 3 Select a pin name ("PORT F1" – "PORT F6") which you want to assign a function to, then select the function you want to assign.
 - For selectable functions, see the tables below.

Functions controlled by MAKE/TRIGGER system

Display	Functions to be controlled	Opening	Short-circuiting
COLOR OFF	Color off	Color	Monochrome
ASPECT	Changes the aspect ratio.	4:3	16:9
A.MARKER	AREA MARKER display	Off	On
S.MARKER	SAFETY MARKER display	Off	On
TIME CODE*4	Time code display	Off	On
1:1	Displays in 1:1 mode.	Off	On
SCR CHECK	Screen check*5	☞ "14 SCREENS CHECK button/lamp" on page 6	
I/P MODE	I/P MODE*5	☞ "16 I / P MODE button/lamp" on page 6	
SDI 1*4	Changes the input to "SDI 1."	Invalid	Valid
SDI 2*4	Changes the input to "SDI 2."	Invalid	Valid
DVI	Changes the input to "DVI."	Invalid	Valid
COMP./RGB	Changes the input to "COMPO./RGB."	Invalid	Valid

Display	Functions to be controlled	Opening	Short-circuiting
VIDEO 1	Changes the input to "VIDEO 1."	Invalid	Valid
VIDEO 2	Changes the input to "VIDEO 2."	Invalid	Valid
EXT.SYNC	Changes the sync signal.	Internal sync	External sync
TALLY	Controls the tally lamp.	Unlit	Lights
TALLY SEL	Selects the color of the tally lamp.	Green	Red
MONI. NAME	☞ "MONITOR NAME" on page 13	Off	On
MUTING	Muting on/off	Off	On
MARK.SEL	Selects the items of "AREA MARKER"*6	Non-"R-" items	"R-" items
L.METER*4	Audio level meter display	Off	On
STATUS	Status display*7	☞ "About the Status Display" on page 7	
— — —	No function	—	—

*4 DT-V24L1D and DT-V20L1D only

*5 Must be controlled with the TRIGGER system.

*6 Selects which functions in "AREA MARKER" are activated, "R-" items or non-"R-" items (☞ page 10).

*7 Displays the information shown when INPUT SELECT button of the current input is pressed (☞ "About the Status Display" on page 7). While controlling with MAKE (make contact) system, the information is displayed only at the moment of short-circuiting.

NOTE

- You cannot assign the same function to different pin terminals.
- The TRIGGER system switches each function by short-circuiting the pin terminal for about 1 second and opening it.

Operation

- 1 Set "PARA REMO SEL" of "REMOTE SETTING" to "MAKE" or "TRIGGER" in the set-up menu.
- 2 Short-circuit the 7th pin terminal (external control) to the 8th pin terminal (GND) so that the monitor can be controlled by the external control.
- 3 When selecting "MAKE" (make contact) system: Operate each function by short-circuiting the corresponding pin terminal to the 8th pin terminal (GND) or opening it.
When selecting "TRIGGER" system: Operate each function by pulse control, that is short-circuiting the corresponding pin terminal to the 8th pin terminal (GND) for about 1 second and opening it.

NOTE

- When changing the input with MAKE (make contact) system, only one pin terminal must be short-circuited. (Other pin terminals must be opened.)
- When selecting the "TRIGGER" system, you can operate only one function at a time. Operate the functions one by one.

■ Using the serial communication

You can control the monitor from a personal computer etc. via RS-485 or RS-232C terminal.

<Communication specifications>

Input terminal	Cable	Terminal specification	Communication specifications
RS-485	A straight LAN cable	the right	Baud Rate : 4800 bps
RS-232C	A straight cable with a D-sub 9-pin connector (male for the monitor, female for the personal computer etc.)		Data Bits : 8 bits
			Parity : No parity
			Stop Bits : 1 bit
			Flow Control : No control
			Communication Code : ASCII Code

<Command outline>

- To start communication, send the connection command from the personal computer etc.
- To terminate the communication, send the termination command from the personal computer etc.

Example of communication procedures

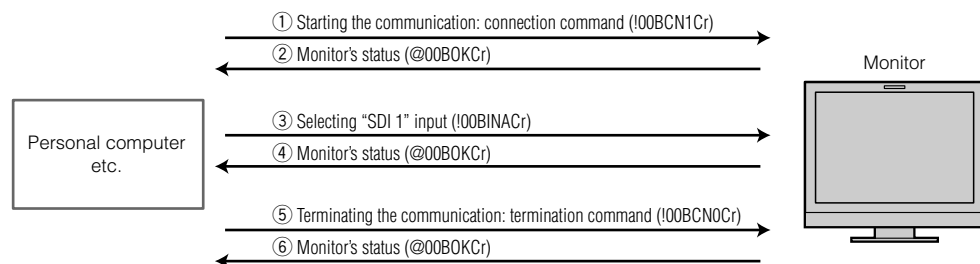

- Commands starting with "!" are operation commands from the personal computer etc. For details, see <Command list> on the right.
- Character strings starting with "@" are status returns from the monitor.

<Command list>

Type	No.	Commands	Functions	Data
Basic commands	1*1	! * * B C N 1 Cr	Starts communication (connection)	No data
	2*1	! * * B C N 0 Cr	Terminates communication (termination)	No data
	3	! * * B I D S E T x x Cr	Assigns the control ID	01 - 99
	4	! * * B I D R E T Cr	Initializes the control ID	No data
	5	! * * B I D D S P x x Cr	Displays/hides the ID	00: Hide 01: Display
	6	! * * B I D C H K x x Cr	Flashes/hides the selected ID No. of the monitor	00: Hide 01: Display
	7	! * * B M E N U Cr	Displays the main menu/Quits the menu operation	No data
	8	! * * B U P Cr	Moves the cursor upward (Δ)	No data
	9	! * * B D O W N Cr	Moves the cursor downward (∇)	No data
	10	! * * B A D J R Cr	Makes setting/adjustment (▷)	No data
	11	! * * B A D J L Cr	Makes setting/adjustment (◁)	No data
	12	! * * B S E T U P Cr	Displays the set-up menu	No data
	13*1	! * * B P W 1 Cr	Turns on the monitor	No data
	14	! * * B P W 0 Cr	Turns off the monitor (standby)	No data
	15*2	! * * B I N A Cr	Selects "SDI 1" input	No data
	16*2	! * * B I N B Cr	Selects "SDI 2" input	No data
	17	! * * B I N C Cr	Selects "DVI" input	No data
	18	! * * B I N D Cr	Selects "COMPO. / RGB" input	No data
	19	! * * B I N E Cr	Selects "VIDEO 1" input	No data
	20	! * * B I N F Cr	Selects "VIDEO 2" input	No data
	21	! * * B D I S P Cr	Displays the status*3	No data
	22	! * * B A M U T E x x Cr	Turns muting on/off	00: Off, 01: On
	23	! * * B A S P x x Cr	Changes the aspect ratio	00: 4:3, 01: 16:9

*1 These commands can be used while the monitor is off (standby).

*2 These commands are available for only DT-V24L1D and DT-V20L1D.

*3 Displays the information shown when INPUT SELECT button of the current input is pressed (see "About the Status Display" on page 7). While controlling with MAKE (make contact) system, the information is displayed only at the moment of short-circuiting.

- "*" is monitor's ID. Normally, set to "00."
- Enter the appropriate data to "xx".
- "Cr" is 0Dh.

<Specifications of RS-485 terminal>

This is a female terminal.

Pin No.	IN terminal signal	OUT terminal signal
1	TXD +	TXD +
2	TXD -	TXD -
3	RXD +	RXD +
4	NC	NC
5	NC	NC
6	RXD -	RXD -
7	NC	NC
8	GND	GND

<Specifications of RS-232C terminal>

This is a female terminal.

Pin No.	Signal
1	NC
2	RXD
3	TXD
4	NC
5	GND
6	NC
7	RTS
8	CTS
9	NC

- The 7th terminal and the 8th terminal are connected.

Solutions to common problems related to the monitor are described here. If none of the solutions presented here solves the problem, unplug the monitor and consult an authorized dealer or service center.

Symptom	Probable cause and corrective action	Page
No power supply	<ul style="list-style-type: none"> Firmly insert the power plug. 	8
No picture with the power on	<ul style="list-style-type: none"> Connect the signal cable firmly. Turn on the power of the connected component and set the output correctly. Select the correct input with INPUT SELECT buttons. Check if the input signal format is acceptable to the monitor. 	6 • 8 • 9
No sound	<ul style="list-style-type: none"> Connect the signal cable firmly. Turn on the power of the connected component and set the output correctly. Adjust the volume level. Deactivate the muting function. 	6 • 8 • 9
“OTHERS” or “Out of range” appears.	<ul style="list-style-type: none"> Check if the input signal format is acceptable to the monitor. 	7 • 9
“NO SYNC” appears.	<ul style="list-style-type: none"> Connect the signal cable firmly. Select the correct input with INPUT SELECT buttons. Turn on the power of the connected component and output video signals. Or, check if the video output of the component (video output setting of the VCR or graphic board of the computer) is set correctly. 	6 • 8 • 9
Wrong color, no color	<ul style="list-style-type: none"> Adjust the each picture adjustment knob on the front panel or adjust the items of “PICTURE SUB ADJ.” in the set-up menu. Or, perform “reset” in “PICTURE SUB ADJ.” Select the proper color system (“COLOR SYSTEM”) in “PICTURE FUNCTION.” Adjust the items of “WHITE BALANCE SET.” in the set-up menu. Or, perform “reset” in “WHITE BALANCE SET.” 	6 • 11 • 12
The picture becomes blurred.	<ul style="list-style-type: none"> Adjust the picture contrast or brightness by using the adjustment knobs on the front panel. Or, adjust “CONTRAST” or “BRIGHT” of “PICTURE SUB ADJ.” in the set-up menu. 	6 • 12
Wrong picture position, wrong picture size.	<ul style="list-style-type: none"> Adjust the picture size (H SIZE/V SIZE) or position (H POSITION/V POSITION) of “SIZE/POS. ADJ.” in the set-up menu. For some signals, the picture cannot be displayed fully in the effective screen area. There is no sure method to solve this problem. Check if the input signal format is acceptable to the monitor. 	9 • 12
Some items do not appear on the menu.	<ul style="list-style-type: none"> The items which are not available for the current input or the current input signal are not displayed on the menu. Change the input or the input signal. 	–
Buttons on the monitor do not work.	<ul style="list-style-type: none"> Set “CONTROL LOCK” in the set-up menu to “OFF.” 	13

The following are not malfunction.

- When a still image is displayed for a long time, it may remain on the screen after the picture changes. This is due to the characteristics of the LCD display and is not malfunction. The remaining picture will disappear after a while.
- The red spots, blue spots and green spots on the panel surface are a normal characteristic of LCD displays, and not a problem. The LCD display is built with very high precision technology; however, be aware that a few pixels may be missing or constantly lit.
- The following symptoms are problems only when pictures or sounds are not played back normally.
 - A slight electric shock occurs when you touch the monitor.
 - The top and/or rear panel of the monitor becomes hot.
 - The monitor emits a cracking noise.
 - The monitor emits a mechanical noise.

Self-check program

When the screen goes blank, and one or some of the INPUT SELECT lamps (COMPO. / RGB, VIDEO 1 and VIDEO 2) on the front control panel start flashing...

This monitor has a self-check function, which allows it to detect malfunctions and alert you. This makes troubleshooting easier. Whenever a problem occurs, one or some of the INPUT SELECT lamps will flash. If this happens, follow the steps below and contact your dealer to resolve the problem.

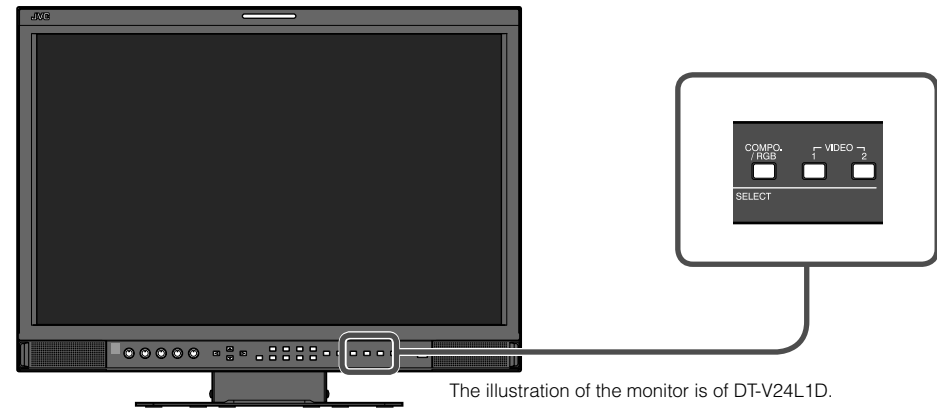

The illustration of the monitor is of DT-V24L1D.

- 1 Check which lamps are flashing.
- 2 Press the standby button to turn off (standby) the monitor.
- 3 Disconnect the AC power cord from the AC outlet.
- 4 Contact your dealer with the information about which lamps are flashing.

NOTE

- If you turn on the monitor soon after turning it off (standby) (or after a short-term power failure), or plug in the AC power cord soon after unplugging it, the INPUT SELECT lamps may flash, and no image may be displayed. When this happens, unplug the AC power cord and wait at least 10 seconds before plugging it in again. If the INPUT SELECT lamps does not flash, you can use the monitor as usual.

Specifications

General

Model name	DT-V24L1D/DT-V24L1	DT-V20L1D/DT-V20L1
Type	Multi format LCD monitor	
Screen size	Type 24 wide format	Type 20 wide format
Aspect ratio	16:10	
LCD panel	24" wide, active matrix TFT	20" wide, active matrix TFT
Effective screen size	Width : 518.4 mm (20 3/8") Height : 324 mm (12 3/4")	Width : 433.4 mm (17 1/16") Height : 270.9 mm (10 5/8")
Number of pixels displayed	1 920 x 1 200	
Number of colors displayed	16.77 million (256 colors for each RGB)	
Viewing angle (TYP.)	176° (Horizontally), 176° (Vertically)	170° (Horizontally), 170° (Vertically)
Brightness (at least) (TYP.)	400 cd/m ²	
Contrast ratio (TYP.)	1 000:1	800:1
Horizontal/vertical frequency (computer signal)	H : 31.469 kHz – 75.000 kHz V : 60 Hz ± 5 Hz	H : 31.469 kHz – 75.000 kHz V : 60 Hz ± 5 Hz
	* Some signals within this frequency range may not be displayed ("Out of range" is displayed).	
Compliant video signal format	☞ "Available signals" on page 9	
Format (DT-V24L1D and DT-V20L1D only)	HD SDI : BTA S-004B, SMPTE292M SD SDI : ITU-R BT.656 : 525/625 SMPTE259M : 525 EMBEDDED AUDIO : SMPTE299M, SMPTE272M	
Audio output	Internal speaker : 1 W + 1 W	
Operating conditions	Operating temperature : 5° C – 35° C (41° F – 95° F) Operating humidity : 20 % – 80 % (non-condensing) * Slightly variable depending on ambient conditions for installation.	
Power requirements	AC 120 V/AC 220 – 240 V, 50 Hz/60 Hz	
Rated current	1.15 A (AC 120 V)/0.67 A (AC 220 – 240 V)	1.00 A (AC 120 V)/0.60 A (AC 220 – 240 V)
External dimensions (excluding protruding parts)	Width : 564 mm (22 1/4") 564 mm (22 1/4") Height : 448.6 mm (17 3/4") 408 mm (16 1/8") Depth : 243 mm (9 5/8") 99 mm (4") (with the stand) (without the stand)	Width : 477 mm (18 7/8") 477 mm (18 7/8") Height : 394.6 mm (15 5/8") 354 mm (14") Depth : 243 mm (9 5/8") 99 mm (4") (with the stand) (without the stand)
Weight	11.6 kg (25.5 lbs) (with the stand) 8.7 kg (19.1 lbs) (without the stand)	10.3 kg (22.7 lbs) (with the stand) 7.4 kg (16.3 lbs) (without the stand)
Accessories	AC power cord x 1, Power cord holder x 1, Screw x 2 (for power cord holder)	

Notice on transportation

This monitor is precision equipment and needs dedicated packing material for transportation. Never use any packing material supplied from sources other than JVC or JVC-authorized dealers.

Options (not supplied)

RACK MOUNT ADAPTER (DT-V20L1D and DT-V20L1 only): RK-C20L1

Input/output terminals

Model name	DT-V24L1D/DT-V20L1D	DT-V24L1/DT-V20L1
Video	VIDEO (INPUT 1)	Input/output of composite signal : 1 line, BNC connector x 2, 1 V(p-p), 75 Ω
	VIDEO (INPUT 2)	* The input (IN) and output (OUT) terminals are bridge-connected (auto termination).
	DVI-D (HDCP)	DVI-D signal input (compatible with HDCP) : DVI-D connector x 1 (compatible with DDC2B)
	COMPO./RGB (G/Y, B/Pb/B-Y, R/Pr/R-Y)	Input/output of analog component signal/analog RGB signal : 1 line, BNC connector x 6 Video signal : G/Y : 1 V(p-p), 75 Ω (including sync signal) B/Pb/B-Y, R/Pr/R-Y : 0.7 V(p-p), 75 Ω * The input (IN) and output (OUT) terminals are bridge-connected (auto termination).
	EXT.SYNC (CS)	Input/output of composite sync signal : 1 line, BNC connector x 2, 0.3 V(p-p) – 4 V(p-p), 75 Ω (tri-level sync, negative polarity sync (bi-level), and BB) (including no video signal) * The input (IN) and output (OUT) terminals are bridge-connected (auto termination).
	HD/SD SDI (IN 1)	Digital signal input (compatible with EMBEDDED AUDIO) : auto detection, 1 line, BNC connector x 1
	HD/SD SDI (IN 2)	
	HD/SD SDI (SWITCHED OUT)	Digital signal output (compatible with EMBEDDED AUDIO) : 1 line switched out, BNC connector x 1
Audio	AUDIO ASSIGN (IN 1)	Analog audio signal input : 1 line, RCA connector x 2, 500 mV (rms), high impedance
	AUDIO ASSIGN (IN 2)	
	AUDIO ASSIGN (MONITOR OUT)	Analog audio signal output : 1 line, RCA connector x 2, 500 mV (rms)
External control	REMOTE (MAKE/TRIG.)	☞ "Using the MAKE/TRIGGER system" on page 14
	REMOTE (RS-485)	
	REMOTE (RS-232C)	☞ "Using the serial communication" on page 15

- For easy understanding, pictures and illustrations are shown by being emphasized, omitted or composed, and may be slightly different from actual products.
- Design and specifications are subject to change without notice.
- All company names and product names mentioned herein are used for identification purposes only, and may be the trademarks or registered trademarks of their respective companies.

The illustrations of the monitor are of DT-V24L1D.

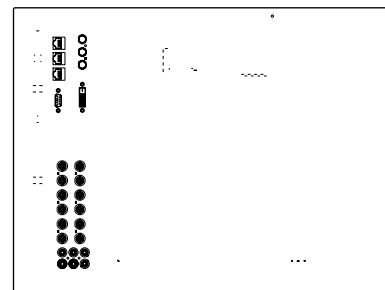
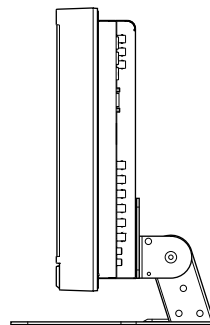
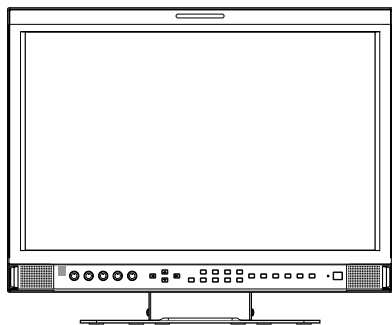

The illustrations of the monitor are of DT-V20L1D.

JVC