

BR16.2A
Built-in Larder Fridge

Instruction manual

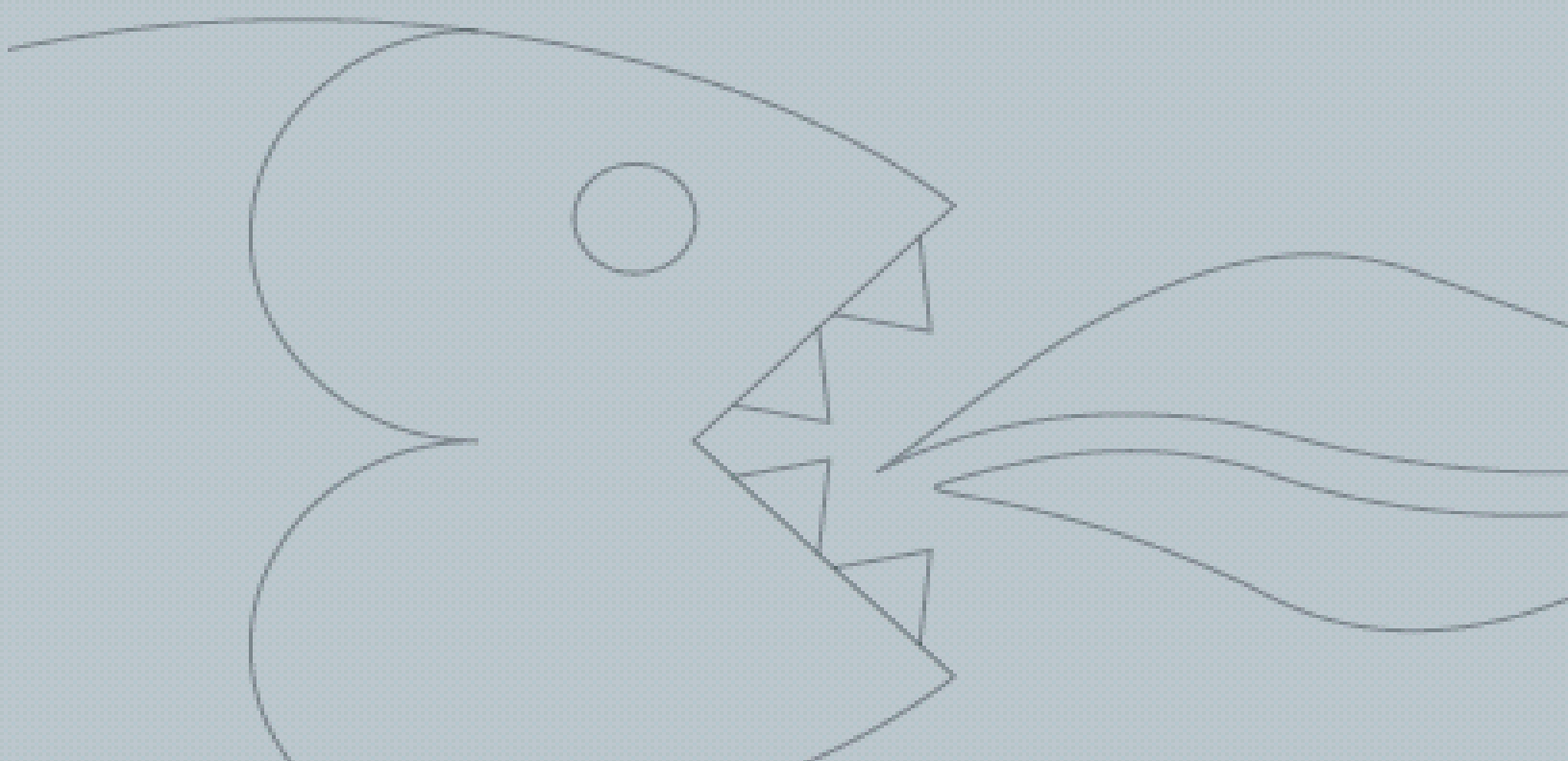

User Manual for your

BR16.2A BUILT-UNDER LARDER FRIDGE



NOTE: This User Instruction Manual contains important information, including safety & installation points, which will enable you to get the most out of your appliance. Please keep it in a safe place so that it is easily available for future reference.

CONTENTS

YOUR APPLIANCE'S SPECIFICATIONS3

SAFETY INFORMATION / ENVIRONMENTAL NOTE .. 4

USING YOUR FRIDGE.....5-8

YOUR BR16.2A FRIDGE5

BEFORE USING YOUR FRIDGE.....6

USING YOUR FRIDGE.....7-8

ARRANGING FOOD IN YOUR FRIDGE9-10

NOTES ON USING YOUR FRIDGE11

CLEANING AND MAINTENANCE.....12-13

DEFROSTING / TIPS FOR SAVING ENERGY.....14

INSTALLING YOUR FRIDGE.....15

FITTING THE DÉCOR DOOR17-18

HOW TO REVERSE THE DOOR SWING19

TROUBLESHOOTING20-21

CONDITIONS OF GUARANTEE.....22

CONTACT DETAILS.....23

HT mod 010306

Specifications of your BR16.2A Built-in fridge

Congratulations on purchasing a Baumatic BR16.2A Built-under Fridge with icebox!

Your Fridge has:

- ↻ ***Gross capacity: 146 litres***
- ↻ ***Net capacity: 145 litres***
- ↻ ***Energy efficiency class: A***
- ↻ ***Automatic Fridge Defrost***
- ↻ ***Adjustable Thermostat***
- ↻ ***Egg Rack***
- ↻ ***3 Wire Shelves***
- ↻ ***2 Salad crispers***
- ↻ ***Reversible door***

Dimensions mm (H x W x D)
878-882 x 560 x 600

To fully enjoy using your appliance long into the future, please firstly familiarise yourself with the specifications, safety advice and operational instructions included in this manual.

NOTE:

When you install your Fridge, it is important to bear in mind its climatic rating.

In order to find out the climatic rating of your appliance, check the data rating tag inside your refrigerator. It indicates the ambient temperature range within which your appliance will function.

Important Safety Information: Please Read this before installing & using.

ELECTRICAL SAFETY

 This appliance complies with Directives 89/368/EEC, 73/23/EEC and following changes.

- **NOTE** - This appliance must be grounded. In the event of a malfunction or breakdown, grounding will reduce the risk of electric shock by providing a path of least resistance of electrical current. You will be able to tell if it is because a non-grounded appliance will give off an electrical discharge. **Manufacturer declines all responsibility for any damage due to non-grounding of appliance.**
 - DURING THE GUARANTEE PERIOD ONLY BAUMATIC SERVICE ENGINEERS OR AN AUTHORISED AGENT OF BAUMATIC SHOULD CARRY OUT REPAIRS ON THIS UNIT.
 - DO NOT USE IF THE SUPPLY CORD IS DAMAGED. NEVER TAKE RISKS WITH FIRE!
- **ENSURE YOU CONNECT THIS APPLIANCE TO A SUPPLY RATED AT 220-240V (or 200-230V) and 50HZ.**
- **NOTE: the supporting structure is constructed in panels of treated sheet steel, electrostatically enamelled to resist ill-treatment and to give long-lasting beauty and shine.**

 Do not attempt to alter the specifications of this appliance. Doing so could damage the machine, cause injury & invalidate your warranty. **DO NOT USE ADAPTERS/SHUNTS.**

 Do not allow children to play with, near or inside this appliance.

 Do not pull on the power supply cable to free the plug from the wall!

 Do not attempt to use your appliance outdoors or any place where it is likely to come into contact with the elements.

 Do not pull out or insert the plug with wet hands.

 Before any cleaning or maintenance work, ensure that the appliance has been disconnected from the power supply.

 Never allow the back coils of the Appliance to come into contact with any wall surface. **ALWAYS ENSURE THAT THE SPACE INTO WHICH YOU ARE PLACING YOUR APPLIANCE IS FREE OF STORED ITEMS SUCH AS PAPERS OR OTHER FLAMMABLE MATERIALS.**

 NEVER block the VENTILATION OPENINGS OF THE APPLIANCE EITHER INSIDE OR ON ITS EXTERIOR. IT IS VITAL TO KEEP YOUR APPLIANCE WELL VENTILATED SO THAT THERE IS PROPER AIR FLOW BETWEEN THE BOTTOM OF THE UNIT AND THE PLINTH / KICK PLATE ON WHICH IT IS SITTING.

 WARNING – DO NOT DAMAGE THE REFRIGERANT CIRCUIT. AT THE END OF THE FUNCTIONAL LIFE OF THE EQUIPMENT (WHICH USES COOLING GAS R600a [ISOBUTANE]) AND INFLAMMABLE GAS INSIDE THE INSULATING FOAM, IT MUST BE PLACED IN SAFETY BEFORE SENDING IT FOR PROPER WASTE DISPOSAL.

PLEASE OBSERVE ALL INSTALLATION ADVICE IN THIS MANUAL FOR SAFE USAGE OF YOUR APPLIANCE.

Note: Before discarding an old refrigerator/freezer, switch off and disconnect it from the power supply. Cut off and render any plug useless. Ensure that the door cannot jam (removing it is best), regardless of whether or not it can be pushed open from inside. AN OLD FRIDGE/FREEZER CAN BE A DEADLY PLAYTHING FOR CHILDREN!

CONFORMITY TO W.E.E.E. DIRECTIVE

This appliance is marked according to the European directive 2002/96/EC on Waste electrical and Electronic Equipment (WEEE). By ensuring this product is disposed of correctly, you will help prevent potential negative consequences for the environment and human health, which could otherwise be caused by inappropriate waste handling of this product.

The symbol  on the product, or on the documents accompanying the product, indicates that this appliance may not be treated as household waste. Instead it shall be handed over to the applicable collection point for the recycling of electrical and electronic equipment.

Disposal must be carried out in accordance with local environmental regulations for waste disposal. For more detailed information about treatment, recovery and recycling of this product, please contact your local city office, your household waste disposal service or the shop where you purchased the product.

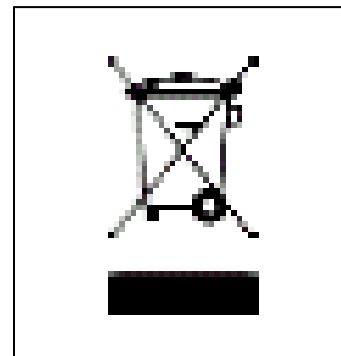

Your BR16.2A Built-under Larder-Fridge:

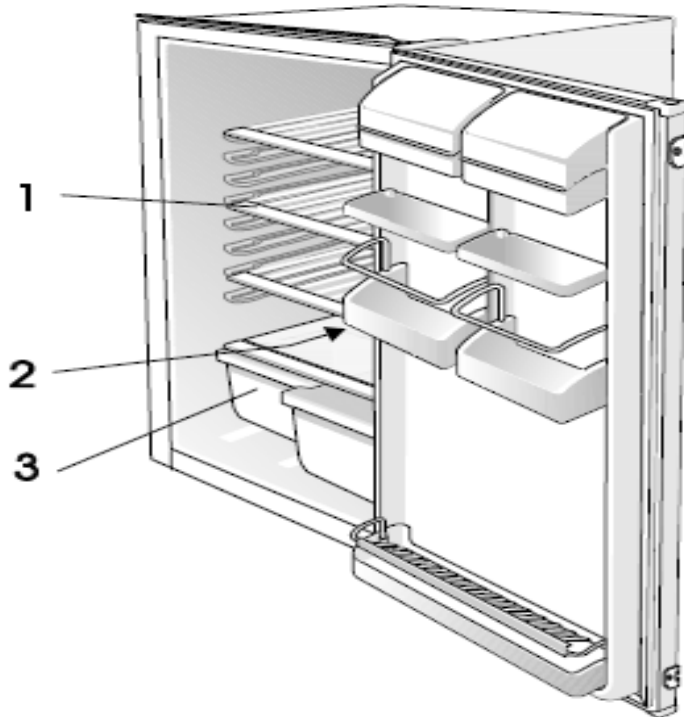

KEY

A

1 SHELF: The shelves may be placed in any of the guide slots within the interior of the appliance. They are protected from sliding out.

To remove a shelf, simply lift the front of the shelf and carefully pull it out of the grooves.

Quickly perishable food should be stored at the back (the coldest part of your refrigerator) but not touching the back wall.

2 DEFROST WATER OUTLET

The interior of the fridge is cooled with the cooling plate at the rear wall. Beneath this, there is a channel and an outlet for defrosted water. It is important

that this channel is never clogged. Use a plastic straw to clear away any dirt.

3 CRISPER TRAYS & SERVING TRAY

The crisper tray at the bottom of your refrigerator is covered by the serving tray. This cover protects fruit and vegetables stored within from drying out.

Note that the door liner holds various shelves containing holders for storing eggs, cheese, butter and yoghurt, as well as smaller packages, tubes, cans, etc. The lower shelf is used for storing bottles.

NOTE: THE LIGHT COMES ON WHEN THE DOOR IS OPENED.

NOTE: BEFORE Using your BR16.2A LARDER-FRIDGE:

UPON DELIVERY:

When your Fridge has been delivered, you will need to wait approximately 2 hours before turning it on. The fluid of the compressor installed in the appliance will need time to settle. **PLEASE DO NOT PLUG IN ANY EARLIER THAN THIS!**

.....
NOTE:

THERE CAN BE AN ODOUR WHEN YOU FIRST SWITCH ON THE APPLIANCE. IT WILL VANISH WHEN THE UNIT STARTS COOLING.

We recommend that you have the Fridge delivered near to where you plan to install it so that this fluid can settle.

SITUATING YOUR FRIDGE

CAUTION: DO NOT PLACE THE APPLIANCE NEAR HEAT SOURCES AND FOLLOW THE INSTALLATION ADVICE SHOWN ON PAGE 15.

FOR FULL INSTALLATION ADVICE, PLEASE SEE PAGE 15

MAKE A NOTE OF THE LOCATION FOR YOUR NEW FRIDGE. MAKE SURE THAT IT WILL FIT PROPERLY SO THAT:

- 1) The doors can open freely and completely.
- 2) You can access your food conveniently.
- 3) There is sufficient space at the back for the cooling coils to give off heat safely & that they do not touch the plug (see SAFETY SECTION).

NOTE: You can reverse the swing of the door to customise the unit to your location. Please see page 18 for details.

USING your Baumatic BR16.2A FRIDGE

YOU SWITCH ON YOUR APPLIANCE by
PLUGGING IT IN & SETTING THE THERMOSTAT inside the Fridge at the upper right-hand side:

Your Fridge's thermostat automatically regulates the inside temperature of the compartments. By rotating the thermostat knob from a low to a higher number position, colder temperatures can be obtained.

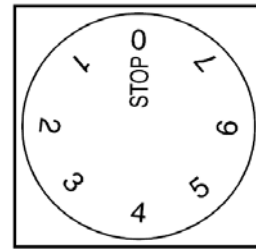

Refrigerator Thermostat setting

Note: Turning the knob setting towards 7 will make all the compartments of your fridge colder. Because the interior temperature may dip below 0°C, you should not leave your fridge on this setting for long periods.

Settings 3-5: Use these mid-settings for longer storage of food in the fridge = mid-coldness. Settings below this will give a milder coldness to the interior of the fridge.

0: This setting will make the fridge **STOP** (the cool system is deactivated), although the light will still function.

REMINDER: *On the maximum setting, your fridge will work harder to maintain this low temperature. So, after you reach this temperature, you should turn the knob to a milder setting (depending on long or short-term storage intentions).*

USING your Baumatic BR16.2A LARDER-FRIDGE

Reminder: Allow the unit time to settle after delivery. If your plug and power socket are now behind the fridge and you still need to move the unit into place, be especially careful. Remember to leave a safe distance between the back of the fridge and the wall or rear of the unit cabinet.

- **You switch your fridge OFF by turning the thermostat knob to position '0'.**

NOTE: When you first switch on the appliance, allow 24 hours for it to cool down to the desired temperature. During this time, DO NOT open the door often or place a lot of food inside the unit.

WARNING! If the appliance is switched off then switched back on again after a short period, the compressor will start up again after approximately half-an-hour. This is part of the normal operation of the appliance.

ARRANGING FOOD IN YOUR FRIDGE

- *To reduce humidity and the consequent increase of frost, NEVER place liquids in unsealed containers in the refrigerator. Frost tends to concentrate in the coldest parts of the evaporator. In time, the unit will need more frequent defrosting if too much humidity develops inside it.*
- *Foods should be properly packed so as to prevent mixing various degrees of moisture and odours. You should use polythene bags or sheets, aluminium foil, wax paper, or store your foods in covered containers or bottles.*
- *Before storing food, remove excessive packaging, like multi-packed yoghurt.*
- *Make sure that you arrange food in such a way that the door can close completely. Be especially wary of protruding items between shelves and the inside of the door, such as bottles.*
- *Some organic solutions such as the oils in lemon and orange peels, acid in butter, can damage plastic over a long period. Be sure that such articles do not make direct contact with the inside of the fridge.*
- *NEVER place warm food inside the refrigerator. Warm food must be allowed to cool at room temperature. It should then be arranged to ensure adequate air circulation in the refrigerator compartment.*

ARRANGING FOOD IN YOUR FRIDGE

- ***DO NOT ALLOW** anything to touch the refrigerator's back wall as it will cause frost. Also, packaging, especially paper, can stick to it and spoil.*
- ***Crispy and delicate foods should be stored in the coldest parts of the fridge.***
- ***DO NOT** open the refrigerator door too often or leave it open for long spells of time.*
- ***ARRANGE** meat and cleaned fish (wrapped in packages or sheets of plastic) which you will then use within 1-2 days.*
- ***You can put fruits and vegetables into the crisper without packing them.***
- ***Use the egg holders provided in the door space to store your eggs.***
- ***Unpleasant odours within may mean your fridge needs cleaning or that food has spoiled.***
- ***If you are planning on being away from your refrigerator for a few days (such as going on holiday), make sure that you remove quickly perishable articles of food from your fridge before you go and dispose of them.***

NOTES ON USING YOUR FRIDGE

ALWAYS Cover and wrap foods, especially if they are PUNGENT.

- **DO NOT place paper or plastic on the shelves which would block the flow of air through the grids.**

NOTE: At the maximum cold setting, with a high outside (ambient) temperature and well-stocked (full or nearly full) compartments, the Fridge's operation may be continuous, leading to the formation of some frost on the evaporator.

Should this happen, the knob must be turned to a less cold position to allow automatic defrosting.

This will also allow lower energy consumption.

REMINDER: *You should regulate the temperature of your Fridge bearing the following in mind:*

- **Ambient temperature**
- **How often the doors are opened and closed**
- **Quantity of food stored in the compartments**
- **Moisture content of what you place in your fridge**
- **The location of your appliance**

IN CASE OF A BLACKOUT (GENERAL POWER FAILURE)

In case of Power Failure, find out how long the electricity will be off. If the failure is not going to be for any longer than 12 hours, leave the food in the fridge and keep the door closed.

If the POWER FAILURE is going to last longer than 12 hours and some food defrosts, consume the latter as soon as possible.

LONG ABSENCES (holidays, etc.): In the case of long absences, the appliance must be switched off, emptied out completely, dried and the doors left open to prevent the formation of mould and unpleasant odours.

CLEANING / MAINTENANCE

NOTE: Before attempting to clean your appliance, UNPLUG IT and make sure you do the following:

WE RECOMMEND THAT YOU CLEAN AND MAINTAIN YOUR REFRIGERATOR ONCE A MONTH.

- ✓ Pay particular attention to the sealing rubber bars of the doors. These need to be kept clean for hygienic reasons as well as to allow the door to close properly.
- ✓ Leave the door open during cleaning.
- ✓ Soak up the water using a sponge.
- ✓ Clean the inside of your Fridge using a solution of soda bicarbonate in warm water (1 tablespoon Bicarbonate to 2 litres of water).
- ✓ Alternatively, you can use a solution of warm water and a little vinegar.
- ✓ Clean the condenser (back of unit) with a broom once a year.

NEVER USE SOLVENTS TO CLEAN THE INSIDE OF YOUR REFRIGERATOR.

MAINTENANCE FROM TIME TO TIME, YOU WILL NEED TO REPLACE THE INTERNAL BULB. REMEMBER TO UNPLUG YOU APPLIANCE FIRST

Find the lamp housing in the top right of the refrigerator's interior.

Gently move the transparent lamp cover plate from the lamp cradle.

Unscrew the bulb and replace with a new one, maximum (10W).

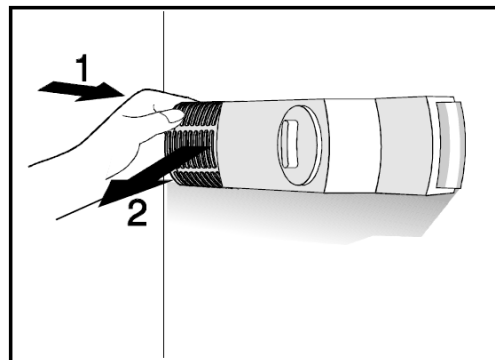

HOW TO CLEAN THE CONDENSER – the condenser consists of a coil structure at the back of your freezer.

To clean it, carefully follow the following instructions:

To optimize the operation of the appliance and to save energy you should periodically clean the dust from the condenser at the back of the appliance.

CAUTION: You will need to move your fridge forward from its cabinet housing to gain access to the condenser at the rear of your appliance.

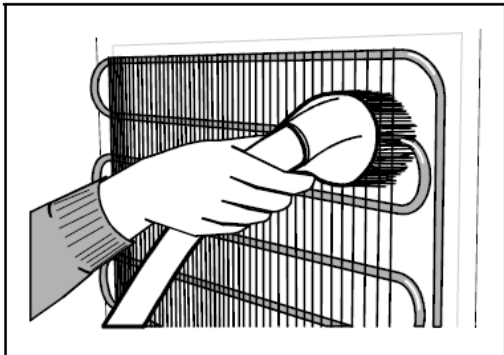

After you have cleaned the appliance, reconnect it to the mains supply and put the food packages back to their place.

- 1) **Carefully move the fridge forward from its cabinet housing until the condenser coil structure at the rear of the appliance is visible.**
- 2) **Use a soft non-metal brush, broom or vacuum cleaner to clear dust away from the condenser.**
- 3) **Replace the fridge properly in its cabinet housing when finished and make sure that the décor door has been properly reattached.**

REMINDER: Disconnect the fridge from the mains before you clean the condenser!

.....

NOTE – YOU WILL ALSO NEED TO CLEAN THE DRAIN PAN ON THE COMPRESSOR FROM TIME TO TIME. IT LOOKS LIKE THIS:

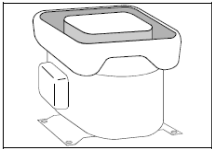

Do not remove the drain pan while cleaning it!

DEFROSTING - Defrosting occurs fully automatically in the refrigerator compartment during normal operation. The defrosted water collected by the evaporating tray evaporates automatically.

TIPS FOR ENERGY SAVINGS

- ✓ **Try not to open the door too often, especially when the weather is wet and hot. Once you open the door, be sure to close it as soon as possible.**
- ✓ **Use higher thermostat settings only if essential and not for constant, long-term use.**
- ✓ **Before loading the appliance with packages of fresh foods, ensure they are cooled to an ambient temperature (except in the case of soup).**
- ✓ **If the door seal (gasket) is damaged, pitted or dirty, the energy consumption will be much higher. To keep the sealing in good condition, be sure not to spill oils or fats on it. A damaged seal will need to be replaced.**
- ✓ **The condenser at the bottom of the appliance must always be clean and free of dust.**

INSTALLING YOUR BR16.2A REFRIGERATOR

A (mm)	B (mm)
575	575-580
875	875-880
1025	1025-1030
1225	1225-1230

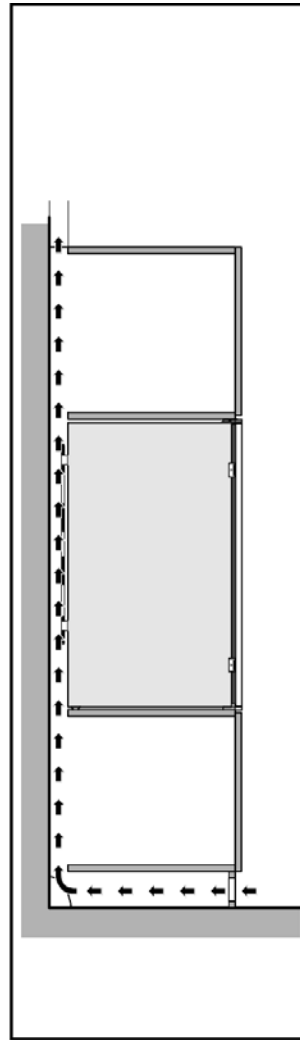
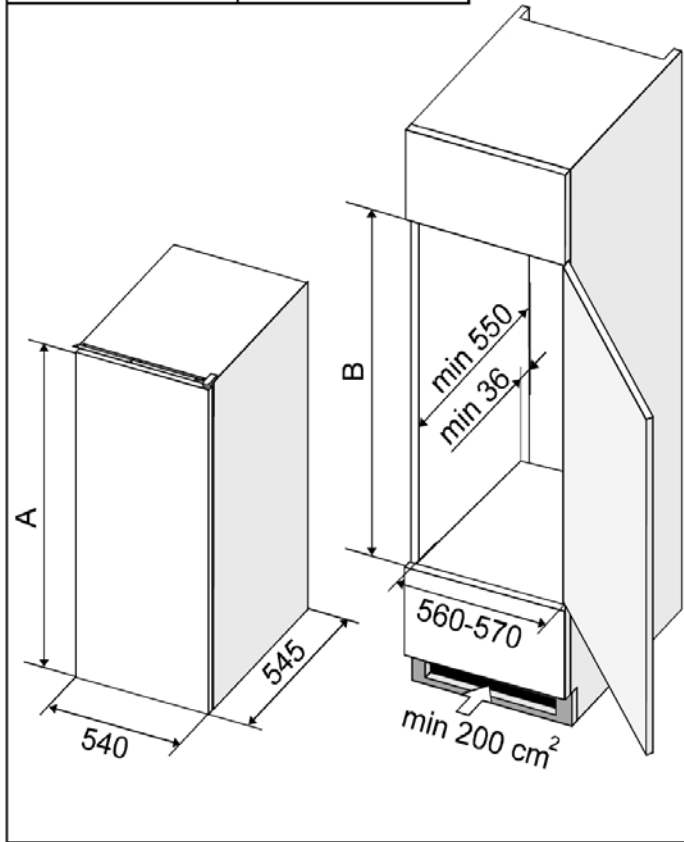

NOTE – YOU NEED THE SPACES SHOWN HERE TO INSTALL YOUR APPLIANCE.

NOTE: Ensure there is sufficient space (36mm) behind the cooling coils at the back of your Fridge.

NOTE: Ensure that you are going to be placing your fridge away from heat sources and in a well-ventilated position. This should be at least 3 cm away from electric or gas stoves and 30 cm from oil or coal stoves. **Note** – you will have to remove the rear wall of your cabinet unit.

- 1) Push the appliance into the kitchen unit's space so there is 38mm (minimum of 36mm) between the rear of the appliance and wall. Allow at least 4mm free space on both sides between the appliance and the interior sides of the kitchen unit (Fig.1, at right).

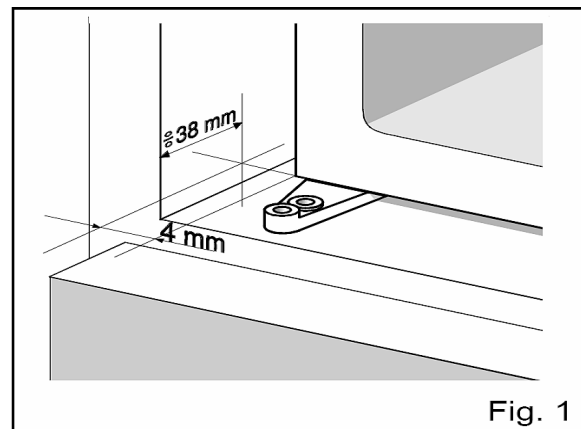

Fig. 1

INSTALLING YOUR APPLIANCE- CONTINUED

Fitting Bar

Install the Fitting Bar (shown in the picture below), so that it attaches to the top of the appliance and underneath the top of the cabinetry, indicated by the arrow:



*Please be aware that the Fitting Bar is not attached to the appliance and needs to be secured during installation.

INSTALLING YOUR BR16.2A REFRIGERATOR

Fitting the Décor Door -

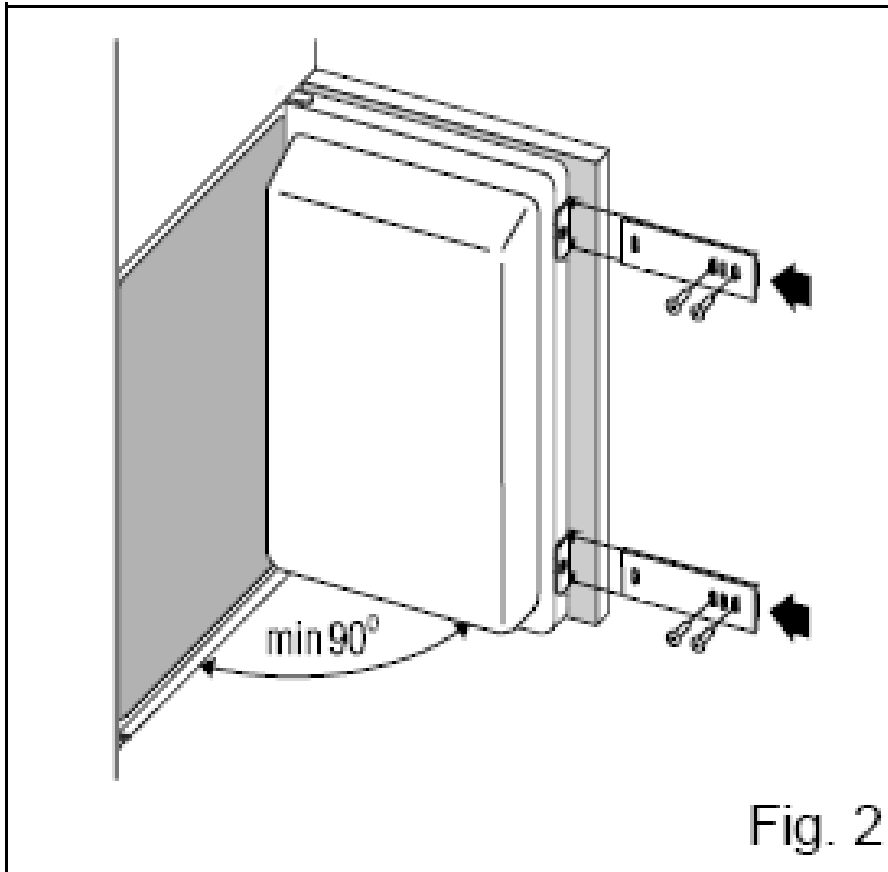

1) Widely open the fridge door & hold it against the kitchen unit door.

2) Fix the slide guides (attached in a plastic bag along with the screws ST 4.2 x 9.5) to the edge of the door. Cover the open holes with the attached caps.

3) Hold the appliance door to the décor door.

4) Insert the slides into the guides and fix them on the kitchen unit door some 15mm from the edge, using the A 4 x 12 screws (Fig. 3, at right).

5) Remove the slide guides and separate the appliance door from the door of the kitchen unit.

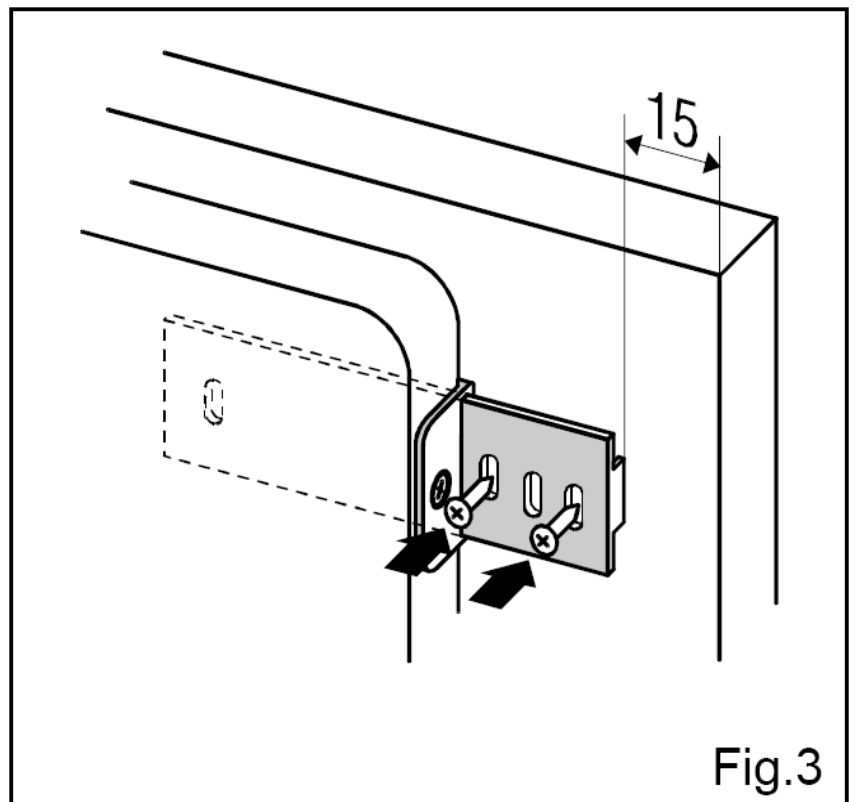

INSTALLING YOUR BR16.2A REFRIGERATOR

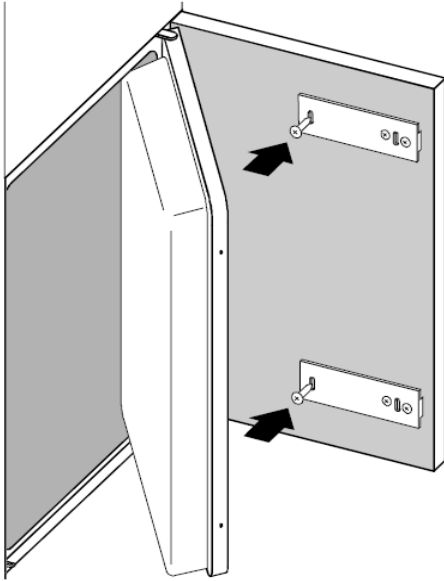

Fig. 4

- 6) Fix the slides, being careful not to move them while fixing them into place (Fig. 4, at left).
- 7) Fix the slide guides to the original position.
- 8) Close the door and check the gasket (it should not be creased). The door should open and close smoothly.

Affixing the door to your Cabinet

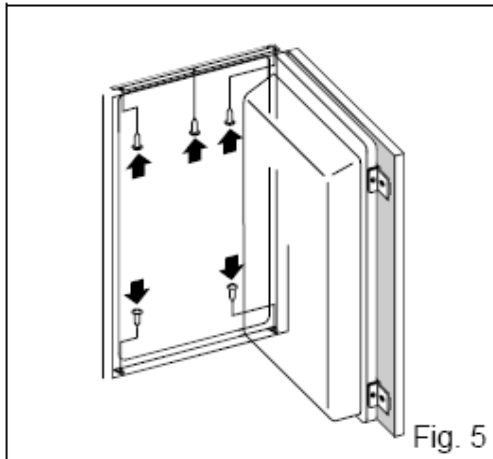

Fig. 5

Fix the appliance to the kitchen unit. On the upper side, fix the three screws A 4 x 12 through the rail and on the lower side with two screws A 4 x 16, through the lower hinges. Drill 5 x 3 mm holes into the positions shown in Figure 5, at left.

Seal the gap on the opposite side of the hinge with the enclosed seal. See Figure 6, at right.

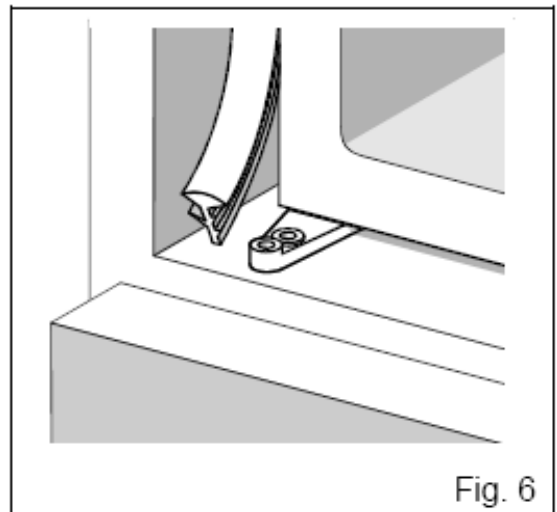
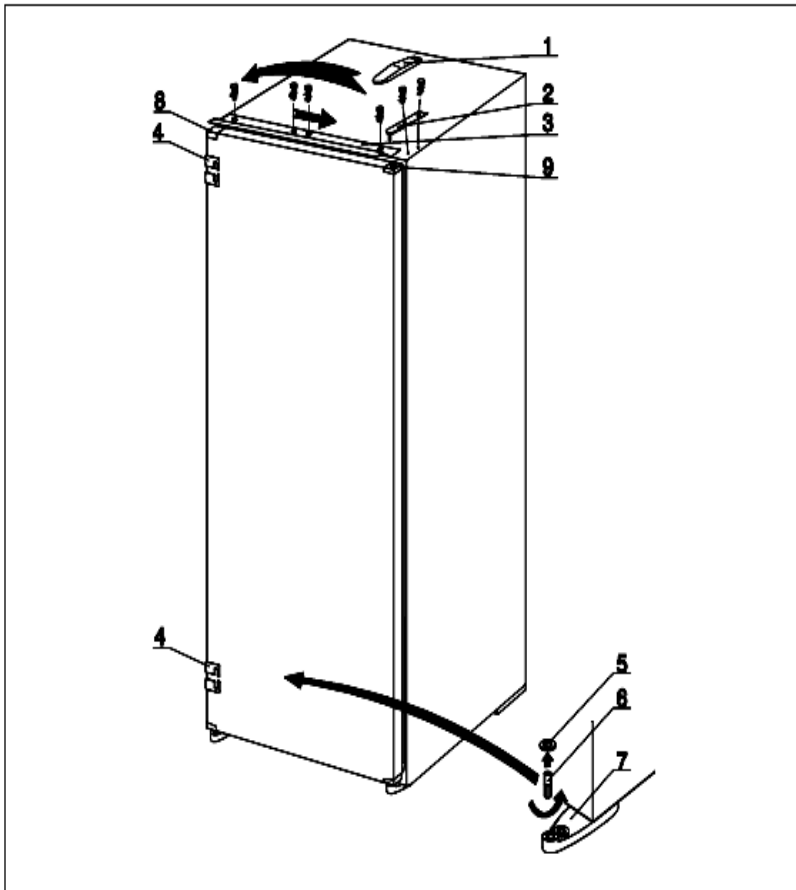

Fig. 6

Reversing the swing of the Door



1 Cover for the upper hinge
2 Upper hinge
3 Upper rail
4 Slide guide
5 Lower hinge washer

6 Lower hinge fastener
7 Lower hinge
8 Corner without a hole
9 Corner with a hole

3) Replace the fastener (6) and the washer (5) in reverse order into the opening of the lower hinge on the opposite side of the appliance.

4) Take off all door corners (8 & 9) and interchange them (instead of the corner with a hole (9), insert the one without the hole (8), and vice versa).

5) Put the door of the appliance on the lower hinge (7).

6) Fix the upper hinge (2) and cover it.

7) Replace the slide guides (4) to the opposite sides of the door.

1) Remove the cover of the upper hinge (2). Unscrew the hinge and take the door off (the door is not fixed on the lower hinge).

2) Unscrew the upper rail (3); replace it to the opposite side of the appliance and fix it.

8) Plug the remaining holes with decorative caps.

9) Check that the seal is not creased or damaged. NOTE: Should the seal not adhere to the fridge's casing perfectly, heat it using a hair dryer, held at a suitable distance so that the

Troubleshooting

Seal can be stretched and flared outward.

Trace a problem using the table below instead of having to call for help.

PROBLEM	WHAT TO DO
YOUR FRIDGE DOES NOT APPEAR TO BE WORKING / NO APPARENT POWER	CHECK THAT THE PLUG IS WELL-INSERTED INTO THE POWER SOCKET
	CHECK THAT THERE IS POWER FROM THE MAINS – THERE MAY BE A BLACKOUT OR YOUR FUSES MAY HAVE BLOWN.
	CHECK THAT THE ELECTRONIC THERMOSTAT (REGULATOR FOUND ON THE INSIDE WALL OF THE FRIDGE-FREEZER NEAR THE TOP) IS IN THE RECOMMENDED FUNCTIONING POSITION AND NOT '0' (OFF).
	CHECK THAT THE SOCKET IS SUFFICIENT AND NO ADAPTER OR EXTENSION LEADS HAVE BEEN USED.
	CHECK THAT THE POWER SUPPLY VOLTAGE CORRESPONDS TO THE APPLIANCE.
YOUR FRIDGE APPEARS TO BE PERFORMING POORLY	YOU HAVE OVERLOADED THE APPLIANCE OR FOOD HAS BEEN PACKED TOO TIGHTLY. TAKE OUT AND CONSUME FOOD; LOOK FOR OUT-OF-DATE FOOD THAT CAN BE DISPOSED OF.
	THE THERMOSTAT SETTING IS SET TOO LOW. SET IT HIGHER.
	ENSURE THAT THE DOOR HAS BEEN CLOSED PROPERLY. FOR INSTANCE, THERE MAY BE A PROBLEM INSIDE THE UNIT, KEEPING THE DOOR OPEN OR ANOTHER FAULT, SUCH AS A BROKEN OR MISSING DOOR SEAL.
	ENSURE THAT THERE IS NO DUST ON THE CONDENSER.
THERE IS A NOISE	ENSURE THAT THERE IS ENOUGH ROOM AT THE REAR AND SIDES OF THE UNIT.
	<p>THE COOLING GAS WHICH CIRCULATES MAY MAKE A SLIGHT NOISE (BUBBLING SOUND) EVEN WHEN THE COMPRESSOR IS NOT RUNNING. THIS IS NORMAL. IF THESE SOUNDS CHANGE, ENSURE:</p> <p>YOUR UNIT IS WELL LEVELLED / NOTHING IS TOUCHING THE REAR OF THE UNIT / NO MATERIAL ON THE APPLIANCE IS VIBRATING.</p> <p>NOTE: A SOUND LIKE FLOWING WATER IS PERFECTLY NATURAL AS IT INDICATES THAT THE REFRIGERANT IS</p>

	FLOWING. THIS IS NOT A MALFUNCTION.
PROBLEM	WHAT TO DO
ICE FORMATION ON THE INNER REAR WALL	<p>IN THE UNLIKELY EVENT THAT ICE DOES FORM ON THE INNER BACK WALL, IT SHOULD BE MANUALLY REMOVED WHEN IT REACHES 3-5MM THICK, USING A PLASTIC SCRAPER. MAKE SURE YOU TURN THE THERMOSTAT DOWN TO 'OFF' OR '0' FIRST.</p> <p>NEVER USE ELECTRIC DEVICES FOR DEFROSTING OR DEFROSTING SPRAYS.</p>
WATER IS LEAKING FROM THE REFRIGERATOR	<p>IN CASE THE DISCHARGE WATER OUTLET BECOMES CLOGGED, OR THE DEFROSTED WATER DRIPS OVER THE CHANNEL, WATER WILL LEAK FROM THE FRIDGE.</p> <p>TO REMEDY THIS:</p> <p>CLEAN THE CLOGGED OUTLET WITH A PLASTIC STRAW.</p> <p>MANUALLY DEFROST THE INCREASED ICE LAYER INSIDE THE APPLIANCE.</p>
<p><i>ADDITIONAL NOTE: SHOULD THE CABINET'S SIDE PANEL HEAT UP, THIS IS NORMAL. IT WILL DO THIS IN SUMMER WITH A HIGH AMBIENT TEMPERATURE OR IF THE DOOR HAS BEEN OPENED AND CLOSED FREQUENTLY. IT IS THE RESULT OF HEAT'S DISSIPATING FROM INSIDE THE CABINET AND IS NOT DETRIMENTAL TO YOUR REFRIGERATOR IN ANY WAY.</i></p>	

BAUMATIC LTD. -CONDITIONS OF GUARANTEE.

Dear Customer,

The conditions of guarantee which apply to your Baumatic appliance are as follows: This product is guaranteed for 12 months from the date of original purchase.

Baumatic Ltd will repair any defect that arises due to faulty materials or workmanship free of charge during this period.

*In addition, your appliance is covered by a 5 year parts warranty. Baumatic Ltd will provide free of charge the parts required to repair the appliance, only if they are fitted by a Baumatic engineer, for any defect that arises due to faulty materials or workmanship within a period of 5 years from the original purchase date.

*An additional and annually renewable insurance scheme for labour is available should you wish to extend the warranty period.

Should any person other than an authorised representative of Baumatic Ltd interfere with the appliance, the policy is negated and Baumatic Ltd will be under no further liability.

The guarantee covers the appliance for normal domestic use only, unless otherwise stated.

Any claims made under the terms of the guarantee must be supported by the original invoice/bill of sale issued at the time of purchase.

This guarantee is transferable only with the written consent of Baumatic Ltd.

If the appliance fails and is considered either not repairable or uneconomical to repair between twelve months and five years from purchase date, a free of charge replacement will not be offered.

The guarantee for any replacement will only be for the remainder of the guarantee on the original product purchased.

This guarantee does not cover:

x Sinks and taps

X Failure to comply with the manufacturer's instructions for use.

X The replacement of cosmetic components or accessories.

X Accidental damage or wilful abuse.

X Subsequent loss or damage owing to the failure of the appliance or electrical supply.

X Incorrect installation.

X Losses caused by Acts of God, civil war, failure to obtain spare parts, strikes or lockouts.

X Filters, fuses, light bulbs, external hoses, damage to bodywork, paintwork, plastic items, covers, baskets, trays, shelves, burner bases, burner caps, decals, corrosion, rubber seals..

In the course of the work carried out it may be necessary to remove the appliance from its operating position. Whilst all reasonable care will be taken, Baumatic Ltd cannot accept responsibility for damage sustained to any property whatsoever in this process.

This guarantee is in addition to and does not diminish your statutory or legal rights.

Contacting Baumatic.

SALES

TEL: 0118 933 6900

FAX: 0118 931 0035

SERVICE

TEL: 0118 933 6911

FAX: 0118 986 9124

SPARES

TEL: 0118 933 6922

FAX: 0118 933 6942

TECHNICAL / ADVICE

TEL: 0118 9336933

FAX: 0118 9336942

For mainland UK and Northern Ireland, please contact one of the above numbers for further information or any other query you may have.

For ROI (Republic of Ireland), please contact one the numbers below:

TEL: 01 - 6266798 FAX: 01 - 6266634

Thank you for buying Baumatic.

*Applies to UK, Scotland, Wales & Northern Ireland only. (Republic of Ireland has 1 year labour and 1 year parts warranty only) .

Baumatic Ltd

Make-up for your kitchen

Headquarters

Baumatic Ltd.
Baumatic Buildings,
6 Bennet Road,
Reading,
Berkshire
RG2 0QX, United Kingdom

Sales Telephone
+44 118 933 6900

Sales Fax
+44 118 931 0035

Service Telephone
+44 118 933 6911

Service Fax
+44 118 986 9124

Spares Telephone
+44 118 933 6922

Technical / Advice Telephone
+44 118 933 6933

E-mail:

sales@baumatic.co.uk

technical@baumatic.co.uk

Http (Internet site):
www.baumatic.com



Baumatic®

www.baumatic.com