

ST-37RS

USER'S MANUAL



WWW.TECHSTEROWNIKI.PL

TECH

TECH

Declaration of Conformity No. 4/2004

Hereby, we declare under sole responsibility that the **ST-37** 230V 50Hz thermoregulator manufactured by TECH, headquartered in Wieprz 1047A, 34-122 Wieprz, is compliant with the Regulation by the Ministry of Economy. (Journal of Laws Dz.U. 155 Item 1089) of July 21, 2007 implementing provisions of the Low Voltage Directive (**LVD**) **2006/95/EC** of January 16, 2007.

The **ST-37** controller has been tested for electromagnetic compatibility (EMC) with optimal loads applied.

For compliance assessment, harmonized standards were used:

PN-EN 60730-2-9:2006.

PAWEŁ JURA

JANUSZ MASTER

WŁAŚCICIELE TECH SP.J.



ATTENTION!

HIGH VOLTAGE!

Make sure the regulator is disconnected from the mains before working on the power supply (cable connections, device installation, etc.)!

All connection works must only be carried out by qualified electricians.

Before activating the controller, measure the motor resetting efficiency and inspect wire insulation.

CAUTION!



**THE DEVICE MAY BE DAMAGED
IF STRUCK BY A LIGHTNING.
MAKE SURE IT IS UNPLUGGED
DURING STORMS**

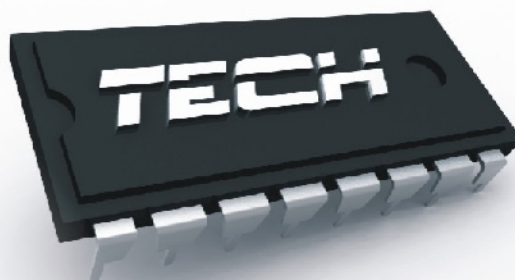

I. Description

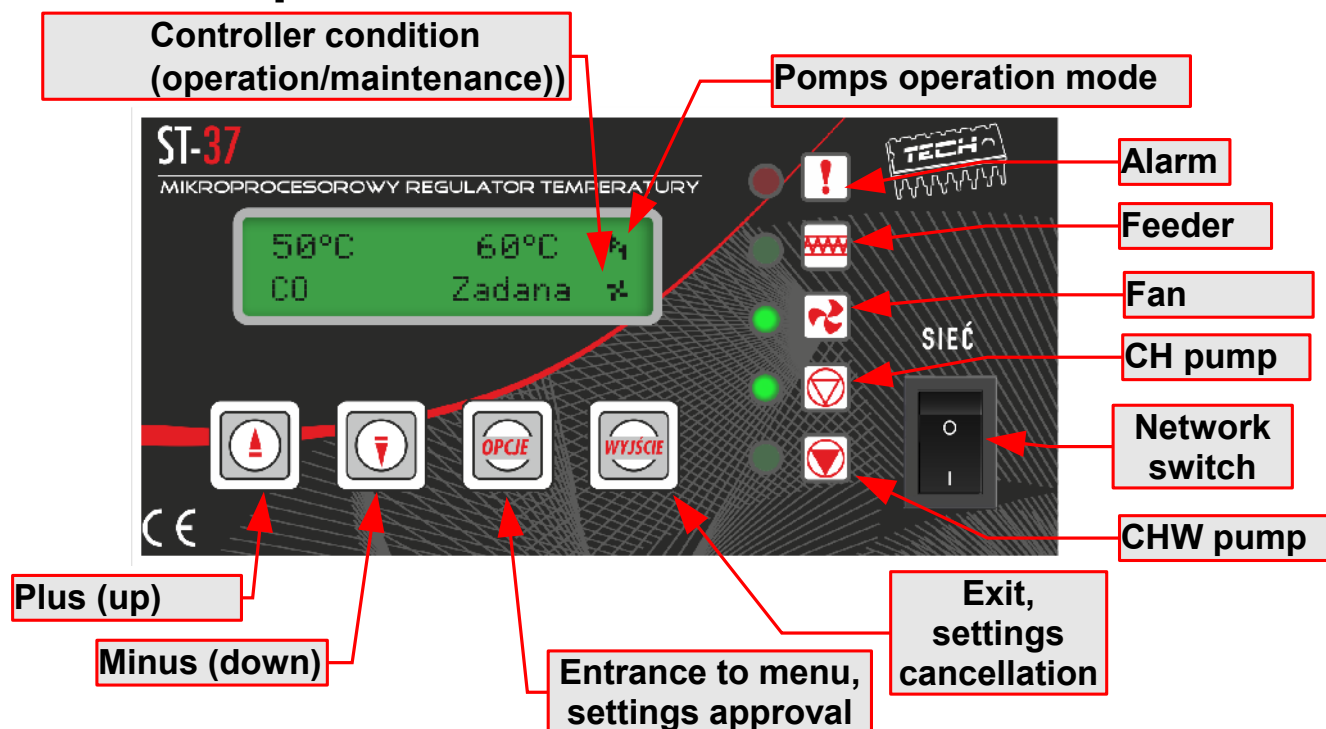

Temperature regulator **ST-37** is designed for CH boilers equipped with a wormwheel or piston feeder. It controls the water circulation pump (C.H.), the usable hot water pump, fan operation and fuel feeder. This device may also cooperate with standard room regulator or with RS communication, GSM module and Internet module. An additional advantage is the possibility to cooperate with two mixing valves by means of additional ST-61 modules with a possibility of weather control.

Each controller should be set individually, for own needs, depending on the type of fuel as well as the boiler type. The TECH company shall not be liable for any incorrect settings of the controller.

II. Basic definitions

Operation - after activation of the controller it switches to *operation mode* and on the display the  symbol is shown. It is the basic functioning condition of the regulator, in which blow-in works all the time, while fuel feeder's operation time is set by the user (both operation time and pause time are set).

Maintenance mode - this mode will be activated automatically, if the temperature is equal or higher than the preset Temperature. In such a case in order to smoothly reduce the temperature of circulating water the regulator will supply the fuel slower and the display will show a symbol: . In order to reduce the temperature correctly, pause time as well as operation time in maintenance should be set correctly.

III. Functions of the regulator

This section describes functions of the regulator, method of changing the settings and menu navigation.

III.a) Main page

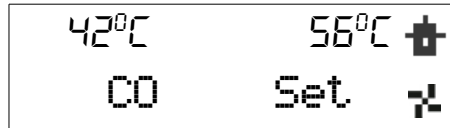

During normal operation of the regulator on LCD display, the homepage is visible, on which the following information is displayed:

- Boiler temperature
- Preset temperature
- Pumps operation mode (see chapter 2.i)
- Boiler operation condition (-operation | - maintenance)

This screen enables fast change of the preset Temperature using PLUS and MINUS buttons. Pressing the OPTIONS button moves the user to menu where the first two functions are displayed. You can navigate the menu, using PLUS and MINUS buttons. Pressing the OPTIONS button transfers to submenu or activates the selected option. To exit the menu or cancel setting 1 button should be used.

Pressing the EXIT button during the main screen view will result in display of screen view change menu, (see chapter 2.b). In the case of lack or damage of usable hot water sensor or selection of house heating operation mode, instead of the current temperature, XX.X will be displayed.

III.b) Screen view

In this function, the user may choose one of the three main thermoregulator operation screens. They are:

- CH Screen (displayed: temperature of the boiler - current and preset), using PLUS/MINUS buttons the set CH may be changed directly from the main screen.
- Usable Hot Water Screen (the boiler temperature is displayed – current and preset), using PLUS/MINUS buttons the set boiler temperature may be changed directly from the main screen.
- Parameters (feeder's temperature [P] and mosfet transistor [M] and current hour are displayed).
- Valve 1 (displays operation parameters of the first valve – current and preset temperature behind the valve and the percentage of its opening), using PLUS/MINUS buttons, you can change the valve preset directly from the main screen.
- Valve 2 (displays operation parameters of the second valve – same as for the first valve)

III.c) Preset CH temperature

This option is used to adjust the set boiler temperature. The user may change the temperature range of the boiler from 45°C to 80°C. The set CH can also be changed directly from the main controller screen with PLUS and MINUS buttons.

III.d) Usable Hot Water preset temperature

This option is used to adjust the set value of the hot utility water temperature. The user may change this temperature within the range of 40°C to 75°C.

III.e) Manual operation



For the user's convenience, the regulator is equipped with a Manual operation mode. In this function, each executive element is switched on and off independently from others.



Pressing the OPTIONS button activates the engine of the chosen device (or alarm) which remains activated until OPTIONS button is pressed again.

The blow-in power, where the user has the possibility to set any rotational speed of the fan in manual operation, is additionally available.

III.f) Operation time*

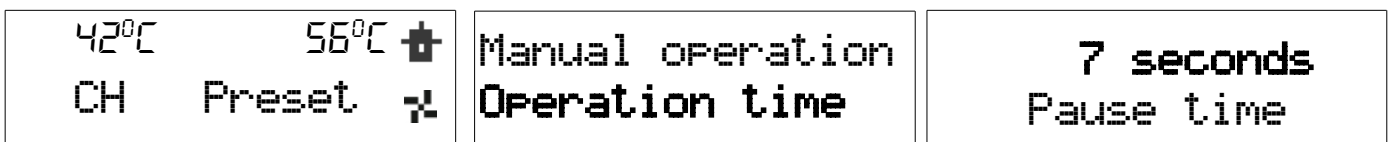

*This function is active only for the boiler with a wormwhel feeder. This option is used to set the operation time of the fuel feeder. The operation time should be set depending on the used fuel and the type of the boiler.

III.g) Pause time

42°C	56°C	⬆	Pause time Blow force	00:30 min:sek Pause time
CH	Preset	⬇		

The pause time is used to set the feeder's operation pause. The pause should be adjusted to the type of fuel combusted in the boiler. Wrong selection of the operation as well as pause time may result in faulty function of the boiler, i.e. coal may not be burnt, the boiler may not reach the preset temperature. Selection of proper times enables correct operation of the boiler.

III.h) Blow force

42°C	56°C	⬆	Pause time Blow force	80 Blow force
CH	Preset	⬇		

This function controls the speed of fan operation. Regulation range is within 1 to 100%.

The fan is always initially activated with full speed – as a result of which it is possible to activate it with a slightly dusted engine.

III.i) Pump operation modes

42°C	56°C	⬆	Blow force PUMPS operat.mode
CH	Preset	⬇	

This function allows you to select one of the following four boiler operation modes:

III.i.1) House heating

⬆	<input checked="" type="checkbox"/> House heating
	<input type="checkbox"/> HW priority

When you select this option the controller switches over to a mode where heating is provided only to heat the central heating circuit. The central heating pump begins to run above the pump activation temperature (factory set at 38°C - see Section III.g). The pump will turn off below this temperature (minus a hysteresis of 2°C).

III.i.2) Boiler tank priority

In this mode, the boiler tank (hot water) pump will be switched on first to run until the set-point temperature is reached (see Section II.e), after which the pump will be turned off and the CH circulating pump will be enabled.

The central heating pump will run all the time until the boiler tank temperature drops below its set-point by the hot water hysteresis value. At that moment the CH pump will turn off and the HW pump will turn on (both pumps operating alternately).



In this mode the fan and the feeder are run only up to 62°C as measured at the boiler (instantaneous set-point) so as to prevent overheating of the boiler.

NOTE: The boiler must be fitted with check valves on the central heating and hot water pump circuits. The valve mounted on the hot water pump is to prevent drawing hot water from the boiler tank.

III.i.3) Pumps in parallel



In this mode both pumps begin to run together (in parallel) above the pump activation temperature. However, these temperatures may vary for each pump, depending on your settings (see Sections III.g-h). When this is so one of the pumps will switch on earlier than the other one, but after both thresholds are crossed both pumps will run together. The central heating pump will run all the time while the hot water pump will turn off when the boiler tank set-point temperature is reached. It will turn on again when the temperature drops by the preset HW hysteresis value below its set-point.

III.i.4) Summer mode

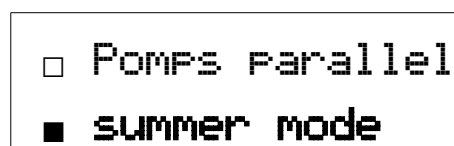

Once this function is activated the central heating pump will be off and the DHW pump will turn on above the preset activation temperature (see Section III.h) and will work continuously until the temperature drops below the activation temperature by the hot water hysteresis value or until the following conditions are met:

$(\text{boiler temperature}) + 2^{\circ}\text{C} \leq (\text{boiler tank temperature})$

In summer mode you only enter the set-point temperature of the boiler, which is also understood to mean the set-point temperature of the boiler tank.

III.j) Operation in maintenance*

62°C CH	56°C Preset	⬆	Operat in maint. Pause in maintn	20 sekund Operat. In maint
------------	----------------	---	-------------------------------------	-------------------------------

* This function is active only for the boiler with a wormwhel feeder. This option is used to set the time of feeder's operation when the boiler is in the maintenance mode.

III.k) Pause in maintenance

62°C CH	56°C Preset	⬆	Operat.In maint. Pause in maint.	30:00 min:sek Pause i maint
------------	----------------	---	-------------------------------------	--------------------------------

The function of pause in maintenance is used for setting fuel feeding pause time of maintenance mode. Wrong selection of the operation time as well as the pause may result in further increase in temperature or unintentional extinguishing of the boiler, or conditions in which it may result in burning of the fuel in the fuel container.

III.l) Fan in maintenance

62°C CH	56°C Preset	⬆	Fan in maintn Weekly control	Workine time Pause time
------------	----------------	---	---------------------------------	----------------------------

This option makes it possible to select appropriate operation and standstill time (pause time) of the fan in maintenance (the so-called blowthroughs).

10 seconds Workine time	15:00 min:sek Pause time
----------------------------	-----------------------------

III.m) Weekly control

Fan in maintn Weekly control	<input checked="" type="checkbox"/> Off <input type="checkbox"/> Mode 1	<input type="checkbox"/> Mode 2 Set mode 1
		Set mode 1 Set mode 2

The function is used to programme daily changes in the boiler temperature. The preset temperature deviations are within the range of +/-100C.

Step #1:

The user needs to set current time and date first (Installer menu > Clock).

Step #2:

The user sets temperature values for individual days of the week (Set mode 1):

Monday– Sunday

Select specific hours and required deviations from the preset temperature (how many degrees the temperature should rise or drop) for each day of the week. Additionally, the preset values can be copied to facilitate the operation.

Example

Monday

preset: 3 00 , temp. -10°C (temperature change– 10°C)

preset: 4 00 , temp. -10°C (temperature change – 10°C)

preset: 5 00 , temp. -10°C (temperature change – 10°C)

In such a case, if the temperature preset on the boiler is 60°C, it will drop 10°C to 50°C between 3 a.m. and 6 a.m. on Monday.

As an alternative to the temperatures being preset separately for individual days, the temperatures can also be set collectively, in the second mode, for the working days (from Monday to Friday) and the weekend (Saturday and Sunday) separately - Set mode 2.

Monday - Friday; Saturday - Sunday

Similarly to the previous mode it is necessary to select specific times and required deviations from the temperature preset for the working days (Monday - Friday) and the weekend (Saturday, Sunday).

Example

Monday - Friday

preset: 3 00 , temp. -10°C (temperature change – 10°C)

preset: 4 00 , temp. -10°C (temperature change – 10°C)

preset: 5 00 , temp. -10°C (temperature change – 10°C)

Saturday - Sunday

preset: 16 00 , temp. 5°C (temperature change +5°C)

preset: 17 00 , temp. 5°C (temperature change +5°C)

preset: 18 00 , temp. 5°C (temperature change +5°C)

In this case, if the preset boiler temperature is 60°C, the temperature will drop 10°C to 50°C between 3 a.m. and 6 a.m. on each day from Monday to Friday. However, the temperature will rise 5°C to 65°C during weekend (Saturday, Sunday) between 4 p.m. and 7 p.m.

Step #3:

The user enables one of two preset modes (Mode1, Mode2) or disables the weekly control option.

Once the mode is enabled the value of the deviation currently set is displayed on the main page of the controller next to the preset central heating system temperature. This, additionally, indicates that the weekly control is active.

Data deletion function is a simple method to remove all previously saved weekly programme settings to enter new settings.

IV.) Installation menu

The functions of the installation menu should be set by the person installing the boiler or service personnel of the manufacturer.

IV.1) Valve 1 (Valve 2)

NOTE: Control with an additional valve (1 or 2) is only possible after you purchase and connect the controller to an additional control module (ST-61), which is not provided as standard equipment with the controller. In order to control two valves you need to connect two ST-61 modules.

The options presented in this chapter are used to adjust the operating settings of an additional mixing valve. In order for the valve to work properly and meet your expectations it should be configured with its parameters set like in the case of the main valve.

1. Registration.

To register an additional valve enter the serial number of the control module of the ST-61 mixing valve servo (look for the five-digit number on the cover of this module). Without this number the valve cannot be activated.

2. Switch on

This feature allows you to temporarily make the valve inactive.

3. Temperature control

This parameter determines the sampling (control) frequency of the water temperature downstream of the valve for the central heating or hot water system. If the sensor indicates a change in temperature (deviation from set-point), then the solenoid will open or close partially by a preset step to restore the set-point temperature.

4. Opening time

You can use this function to set the time for the full opening of the valve, that is to say, how long it takes to open the valve to 100%. This time should be selected according to your valve actuator (shown on the nameplate).

5. Single step

You can use this function to set a percentage value for a single step in the operation of valve opening, that is to say the maximum percentage value of opening or closing that the valve can move in a single step (maximum movement of the valve in one measurement cycle).

6. Minimum opening

Use this function to set the minimum value for valve opening. Below this value, the valve will not close shut.

7. Type of valve

You can use this option to select the type of valve: central heating or floor type.

8. Weather program (weekly valve program)

In order to enable the weather function an outdoor sensor should be installed in a place not exposed directly to sunlight or weather conditions.

After installing and connecting the sensor the Weather program function must be enabled in the controller menu.

For the valve to work properly enter set-point temperatures (downstream of the valve) for the following four intermediate outside temperatures:

TEMP. FOR -20
TEMP. FOR -10
TEMP. FOR 0
TEMP. FOR 10

Heating curve - curve which is used to determine the set-point temperature of the controller based on the outside temperature. In our controller this curve is established based on four temperature set-points selected for their respective outside temperatures. Set-point temperatures must be provided for the following outside temperatures: -20°C , -10°C , 0°C and 10°C .

The more points there are available for constructing the curve, the greater is its accuracy, which allows you to determine its shape in a flexible way. In our case, four points seem to be a very good compromise between accuracy and ease of setting its shape.

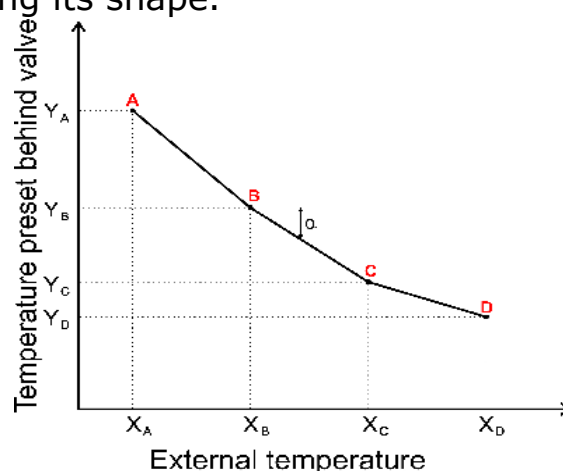

Where in our controller:

$X_A = -20^{\circ}\text{C}$, $X_C = 0^{\circ}\text{C}$,
 $X_B = -10^{\circ}\text{C}$, $X_D = 10^{\circ}\text{C}$,

Y_A, Y_B, Y_C, Y_D – set-point valve temperatures for their corresponding outside temperatures: X_A, X_B, X_C, X_D

After *weather control* is enabled the *valve set-point* parameter is calculated based on the heating curve. By changing this parameter you can decrease or increase all the weather control settings.

9. Room regulator

To regulator **ST-37** or valve module **ST-61** a room regulator can be attached, assigned to mixing valve control. After its activation, the valve is controlled by a room regulator. The user can select the type of room regulator:

→ **TECH regulator (RS communication)**

Every change in room temperature causes a corresponding change in the preset temperature of the mixing valve (see: *Valve 1, 2* – Chapter 2 no. 1 – p. 11 and 12).

In the case of connecting TECH regulator (connection to socket on boiler controller), the user has the possibility to control and change the preset CH and Usable Hot Water temperature, as well as of the mixing valve; any boiler controller alarms are also displayed. When cooperating with the mixing valve, the user has the opportunity to view the current external temperature during the main screen view with valve parameters.

→ **two-state (standard regulator connected with the main controller - ST-37)**

Heating the apartment to the preset temperature will cause reduction in the set temperature of the valve by the value of the parameter of *room temperature reduction* (see: *Valve 1, 2* – Chapter 2 no. 1 – p.13).

→ **valve regulator (standard regulator connected to valve module - ST-61)**

Heating the apartment to the preset temperature will cause reduction in the set temperature of the valve by the value of the parameter *room temperature reduction* (see: *Valve 1, 2* – Chapter 2 no. 1 – p.13). Heating the room regulator in this case will not have effect on the boiler's operation.

In the whole set (boiler controller along with valves) it is possible to use only one TECH room regulator, the remaining may only be standard (two-state).

NOTE: No external voltage can be connected to the output of the room regulator.

10. Return protection

This function permits setting the boiler protection against too cool water returning from the main circulation, which could cause low-temperature boiler corrosion. The return protection operates in such a way that when the temperature is too low, the valve is closed, until the short circulation of the boiler reaches the appropriate temperature. This function also protects the boiler against dangerously high temperature of return in

order to prevent boiling of water.

After switching this function on, the user sets the minimum and the maximum acceptable return temperature.

11. Change in the preset

This setting determines by how many degrees the valve temperature will increase or decrease with unit change in the room temperature (see: Difference in room temperatures). This function is active only with TECH room regulator and is strictly related to the parameter Difference in temperatures.

12. Difference in temperatures

This setting determines a single change in the current room temperature (with accuracy to 0.1°C) when the preset valve temperature change occurs (function active only with TECH room regulator).

Example:

setting: *Difference in room temperatures* **0.5°C**

setting: *Change in the set valve temperature* **1°C** setting:

Preset valve temperature **40°C**

setting: *Preset room regulator temperature* **23°C**

Case 1. If the room temperature increases up to 23.5°C (0.5°C) the valve closes itself to the preset 39°C (by 1°C).

Case 2. If the room temperature drops to 22°C (by 1°C) the valve opens to the preset 42°C (by 2°C).

13. Room temperature reduction

This function is active only in cooperation of the controller with the two-state room regulator (standard or valve). When the room regulator reaches the preset temperature in the apartment, (reports heating), the valve closes itself so that the temperature behind the valve decreases by the temperature of *<room temperature reduction>*.

14. Additional sensors

When two mixing valves are used and you select this function you will be able to select the sensors from which temperature data are to be retrieved for a valve (for return and outside temperature sensors). Temperatures can be retrieved from the sensors of the valve being set (*Own*) or as per the controller sensors (*Main controller*).

15. Sensor calibration

This parameter is used for external temperature sensor calibration. Calibration is made during device installation or after a longer period of use to level the possible measurement deviation. The scope of calibration is within +/- 10°C with the accuracy down to 0.1°C.

16. Factory settings

This parameter makes it possible to return to settings of a given valve, saved by the manufacturer. Restoring factory settings does not change the set valve type (*CH* or *floor*).

17. Valve removal

This function is used to completely remove a valve from the controller memory. *Valve removal* is used for example when removing or replacing a module (the new module requires to be registered again).

IV.2) Pump activation temperature

The option is used to set the activation temperature for central heating and domestic hot water pumps (the temperature is measured on the boiler). None of the pumps will operate if the temperature is lower than the preset one. If the actual temperature is higher than the preset one the pumps are working but they operate depending on the operation mode (see: pump operation modes)

IV.3) Boiler hysteresis

This option is used to set the hysteresis of the set temperature. This is a difference between the temperature of entering the support cycle, and the temperature of return to the operation cycle (for example: when the set temperature has the value of 60°C, and the hysteresis is 3°C, switching into the support cycle will proceed when the temperature increases to 60°C, while return to the operation cycle will proceed when the temperature decreases to 57°C).

IV.4) HUW hysteresis

This option is used to set the hysteresis of the set temperature in the reboiler. It is the maximum difference between the set temperature (that is required in the reboiler) and the current temperature in the reboiler at which the HUW pump will activate. (for example: when the set temperature has the value of 55° C and the hysteresis is 5° C. After reaching the set temperature, that is 55° C, the HUW shuts down and causes activation of the CH pump. Re-activation of the HUW pump will proceed when the temperature decreases to 50° C).

IV.4) Room regulator

Room regulator can be attached to **ST-37** regulator. After its activation, the controller is set by the room regulator. The user can select the type of room regulator:

→ two-state (standard regulator)

Additional heating of the room regulator will cause switching the boiler to *maintenance* mode but it does not turn off the circulating water pump (when

CH temperature is higher than *activation temperature* of pumps)

→ **TECH regulator (RS communication)**

Additional heating of the room regulator will cause switching the boiler to *maintenance* mode but it does not turn off the circulating water pump (when CH temperature is higher than *activation temperature* of pumps).

In the case of connecting TECH regulator, the user has the possibility to control and change the set CH and Usable Hot Water temperature as well as mixing valve temperature; any boiler controller alarms are also displayed. When cooperating with the mixing valve, the user has the possibility to view the external temperature when in the main screen view with valve parameters.

After activation of *Room regulator* option (TECH or standard) on the main screen of the controller at the top part of the display the letter "P" will appear. A flashing letter "P" means that the room is underheated; when the set temperature is reached in the apartment, "P" will glow permanently.

Standard room regulator is connected to the boiler controller by means of a two-core wire in the place described *room regulator*, while TECH regulator is connected by four-core wire ended with RS type plug with a socket marked **RS**.

NOTE: *No external voltage can be connected to the output of the room regulator.*

IV.5) GSM module

NOTE: Controlling of this type is possible after purchasing and connecting to the controller, the additional control module **ST-65** which is not attached to the regulator as a standard feature.

The GSM module is an optional device cooperating with the boiler controller, enabling remote control of the boiler operation with the use of a mobile phone. The User is notified with a text message on each alert of the boiler controller, and by sending an appropriate text message at any time, he or she receives a return message with the information on the current temperature of all sensors. After entering an authentication code it is also possible to remotely change the set temperatures.

The GSM module can also operate independently from the boiler controller. It has two inputs with temperature sensors, single contact input for use in any configuration (detecting short circuit/opening of contacts) and one controlled output (e.g. possibility to connect additional contactor to control any electrical circuit).

When any temperature sensor reaches the preset deactivation temperature, maximum or minimum, the module will automatically send a text message with such information. It is similar in the case of a short-circuit or opening of contact input, which may be used e.g. for simple protection of property.

IV.6) Internet module

NOTE: Controlling of this type is possible after purchasing and connecting to the controller, the additional control module **ST-500** which is not attached to the regulator as a standard feature.

The Internet module is a device enabling remote control of the boiler over the Internet or local network . On the home computer screen the user controls the condition of all boiler system devices and the operation of each device is presented in the animated form.

Apart from the possibility to view the temperature of every sensor, the user has the possibility of introducing changes of the set temperatures for both the pumps and the mixing valves.

After activating the Internet module and selecting the DHCP option, the controller will automatically download such parameters from the local network as: IP address, IP Mask, Gateway address and DNS Address. In the case of any problems with downloading network parameters of the existing network, there is a possibility of setting these parameters manually. The method of obtaining local network parameters has been described in the instructions for *the Internet module*.

The function *Reset module password* may be used when the User, on the login page, has changed the factory user's password to his or her password. When a new password is lost, it is possible to return to the factory password after resetting the module password.

IV.7) Feeder in auto mode

The option allows enabling and disabling the automatic operation of the feeder. The feeder can be disabled to feed fuel manually or to shut the boiler down.

IV.8) Clock

You can use the clock settings to enter the current time and day of the week.

IV.9) Service menu

A 4-digit code has to be input to enter service functions of ST-37 controller. The code is in possession of Tech Company.

IV.10) Language selection

Using this function, the user selects the language in which the controller will be operated.

IV.11) Factory settings

The controller is pre-configured for its operation. However, its settings should be modified to meet your individual needs. You can return to the

factory settings at any time. If you enable the **factory settings** option you will lose all of your own boiler settings, which will be replaced with the settings saved by the boiler manufacturer. From now on you can re-set your own parameters of the boiler.

V.) Protections

To ensure maximally safe and unfailing operation, the regulator has a number of protections. In the case of an alarm, a sound signal is activated and an appropriate message is shown on the display.

V.1) Temperature alarm

This protection is activated only in the **operation** mode (that is when the boiler temperature is lower than *the set temperature*). If the boiler temperature does not increase throughout the period set by the user, the alarm is activated, the feeder and the blow-in are deactivated (the water pump is turned on regardless of the boiler temperature) and a sound signal is activated. An appropriate message will be shown on the display.

V.2) Thermal protection

It is an additional bimetallic mini-sensor (located at the boiler temperature sensor), disconnecting the fan and the feeder in the event of exceeding the alarm temperature: 85° C. Its activation prevents the water in the installation from boiling, in the event when the boiler overheats or the controller is damaged. After activation of this protection, when the temperature goes down to a safe value, the sensor will unlock automatically and the alarm will be deactivated. In the case of damage or overheating of this sensor, the fan and the feeder will be disconnected.

V.3) Automatic sensor control

In the event of damage of each of the sensors the sound alarm is activated, additionally signalling, the defect on the relevant display, e.g.: "**CH sensor damaged**". The feeder and the blow-in is disabled. The pumps operate according to the set temperatures, regardless of alarms.

*In the case of damage of the CH sensor or the feeder, the alarm will be active until the sensor is replaced with a new one. If the HUW sensor is damaged, one should press the **menu** button, which will turn off the alarm and the controller will return to the one pump (CH) operation mode. In order to ensure that the boiler will be able to work in all modes, the sensor must be replaced with a new one.*

V.4) Protection against boiling of water in the boiler

This protection applies only to **reboiler priority** operation mode. When the set reboiler temperature is e.g. 55° C and the actual temperature in the boiler increases up to 62° C (this is the so-called the

priority temperature), then the controller will turn off and the feeder the fan. If the temperature in the boiler still increases up to 80° C, the CH pump will be activated. When the temperature still increases, then the alarm will be activate at the temperature of 85° C. Most often such a condition may appear when the reboiler is damaged, the sensor is improperly fitted or the pump is damaged. However, when the temperature drops, then at the threshold of 60° C the controller will turn on the feeder and the blow-in and will run in the operating mode until the temperature of 62° C is reached.

V.5) Temperature protection

The regulator has an additional protection in the event of damage of the bimetallic sensor. After exceeding the temperature of 85°C, the alarm is activated, signalling the following on the display: "**Temperature too high**". Despite damage of the bimetallic sensor, the controller receives information on the current temperature in the boiler from the electronic sensor. In the case of exceeding the alarm temperature, the fan is turned off and, at the same time, both pumps begin to operate in order to distribute hot water across the house installation.

V.6) Fuel container protection

On the fuel feeder there is an additional temperature measuring sensor. In the event of its significant increase (above 70° C), the alarm is activated; the feeder is activated every 10 minutes, which causes pushing the fuel to the combustion chamber. This way the feeder sensor protects against fuel ignition in the container.

V.7) Fuse

The regulator has a WT 6.3A tubular fuse insert, protecting the network. Using a fuse with a higher value can cause damage to the existing controller.

ATTENTION: The fuse of higher value should not be used. Assembling the fuse with a higher value may cause damage to the controller.

VI.) Maintenance

The **ST-37** controller must be checked for the technical condition of its wires before and during the heating season. You should also check the mounting of the controller, clean it of dust and other contamination. Furthermore, you should also measure the effectiveness of the grounding of the motors (central heating pump, hot water pump and blower).

TECHNICAL DATA

	<i>Specification</i>	<i>Unit</i>	
1	Power supply	V	230V/50Hz +/-10%
2	Power consumption	W	7
3	Ambient temperature	°C	5÷50
4	Feeder output load	A	2
5	Load of circulating pumps outputs	A	0,5
6	Blow-in output load	A	0,6
7	Measurement accuracy	°C	1
8	Temperature endurance of the sensor	°C	-25÷90
9	Fuse insert	A	6,3

VII.) Assembly

NOTE: Installation should be performed by a properly qualified technician! **Do not** install the unit with the power on (make sure that the plug is disconnected from the mains)!

NOTE: Incorrect wiring may damage the controller!

The controller cannot be operated in a closed central heating system. The installation must include safety valves, pressure valves and an equalizing tank to protect the boiler from water boiling in the central heating system.

We are committed to protecting the environment. Manufacturing electronic devices imposes an obligation of providing for environmentally safe disposal of used electronic components and devices. Hence, we have been entered into a register kept by the Inspection For Environmental Protection. The crossed-out bin symbol on a product means that the product may not be disposed of to household waste containers. Recycling of wastes helps to protect the environment. The user is obliged to transfer their used equipment to a collection point where all electric and electronic components will be recycled.



Controller wiring connection diagram

Particular attention should be paid when making cable connections with the controller. Especially, the grounding conductor should be connected properly.

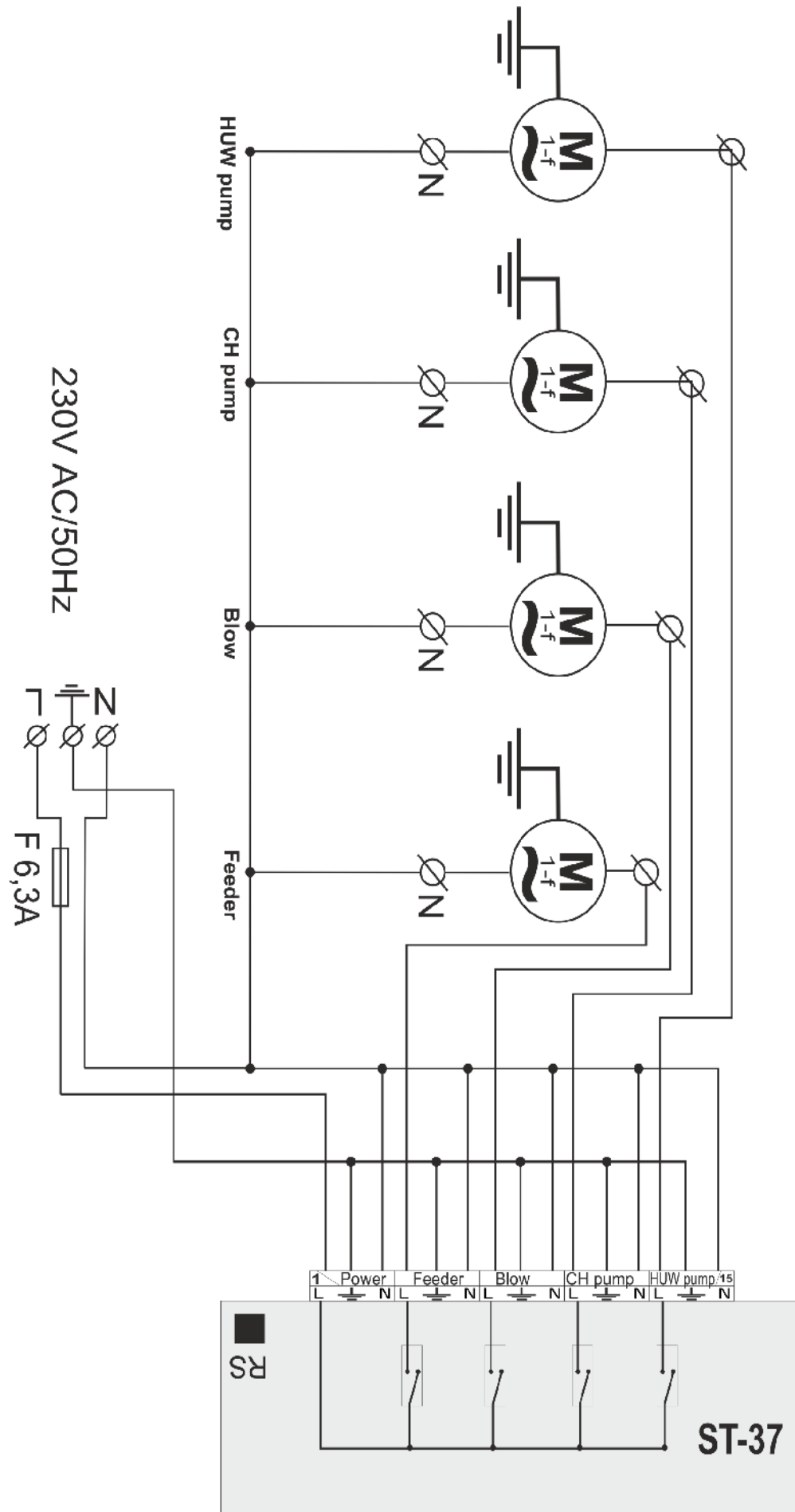

ST-37RS – user's manual

I. Description.....	5
II. Basic definitions.....	5
III. Functions of the regulator.....	6
III.a) Main page.....	6
III.b) Screen view.....	6
III.c) Preset CH temperature	7
III.d) Usable Hot Water preset temperature.....	7
III.e) Manual operation.....	7
III.f) Operation time*.....	7
III.g) Pause time.....	7
III.h) Blow force.....	8
III.i) Pump operation modes.....	8
III.i.1) House heating.....	8
III.i.2) Boiler tank priority	8
III.i.3) Pumps in parallel.....	9
III.i.4) Summer mode.....	9
III.j) Operation in maintenance*.....	9
III.k) Pause in maintenance	10
III.l) Fan in maintenance.....	10
III.m) Weekly control.....	10
IV.) Installation menu.....	12
IV.1) Valve 1 (Valve 2).....	12
1. Registration.....	12
2. Switch on.....	12
3. Temperature control.....	12
4. Opening time.....	12
5. Single step.....	12
6. Minimum opening.....	13
7. Type of valve.....	13
8. Weather program (weekly valve program).....	13
9. Room regulator.....	14
10. Return protection.....	14
11. Change in the preset.....	15
12. Difference in temperatures.....	15
13. Room temperature reduction.....	15
14. Additional sensors.....	15
15. Sensor calibration.....	15
17. Valve removal.....	16
IV.2) Pump activation temperature.....	16
IV.3) Boiler hysteresis.....	16
IV.4)HUW hysteresis.....	16
IV.4) Room regulator.....	16
IV.5) GSM module.....	17
IV.6) Internet module.....	18
IV.7) Feeder in auto mode.....	18
IV.8) Clock.....	18
IV.9) Service menu.....	18
IV.10) Language selection.....	19
IV.11) Factory settings.....	19
V.1) Temperature alarm.....	19
V.2) Thermal protection.....	19
V.3) Automatic sensor control.....	19
V.4) Protection against boiling of water in the boiler.....	20
V.5) Temperature protection.....	20
V.6) Fuel container protection.....	20
V.7) Fuse.....	20
VI.) Maintenance.....	21
VII.) Assembly.....	21
Controller wiring connection diagram.....	21

User's Manual

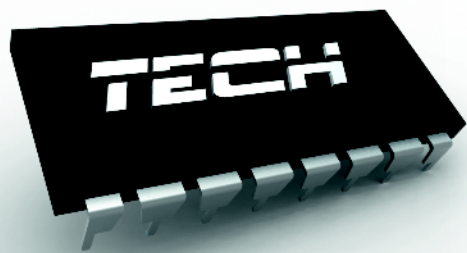

WWW.TECH-REG.COM

All faults should be reported to:

TECH Sp.j.

Wieprz 1047A

34-122 Wieprz

Tel. +48 33 8759380, +48 33 8705105

+48 33 8751920, +48 33 8704700

Fax. +48 33 8454547

serwis@techsterowniki.pl

Monday - Friday

7:00 - 16:00

Saturday

9:00 - 12:00

TECH