



USER MANUAL



C-MAG MAGAZINE SYSTEM 7.62MM

PMAG

CONTENTS

	Pages
Introduction	2, 3
Technical Data	4
Description	5, 6
Drawing: Exploded View	7
Loading / Lubrication	8, 9
Use of Personal Loader	10
Precautionary Measures - Sand	11
Disassembly and Cleaning	12 - 15
Assembly of the C-MAG	16 - 19
Troubleshooting	20, 21
Accessories	22, 23
C-MAG MAGAZINE SYSTEM PMAG	24
List of Part Numbers	25

INTRODUCTION

The C-MAG Magazine PMAG is a 100 round ammunition magazine, manufactured to the highest production standards. It meets and exceeds NATO Military Specifications.

The patented design provides for equal distribution of the ammunition in each of the twin-drums. Rounds are fed alternately from each drum through the feed clip into the weapon, resulting in a fixed center of gravity during firing. Using a unique rotation device and low torsion stress springs, the C-MAG is the world's first magazine with a full 100-round capacity, capable of being pre-loaded and stored indefinitely. The compact design allows for better ground clearance and stability.

The C-MAG PMAG is installed in the weapon like the standard issue magazine **with the bolt in the open position**. The bolt will be in the closed position when the magazine is empty.

The C-MAG can be reloaded and reused repeatedly with an estimated life cycle in excess of 60,000 rounds.

The PMAG is compatible with the following weapons: DPMS, KAC SR-25, LWRC REPR, LARUE OBR, Bushmaster .308 ORC, Remington R-25, POF P-308, JP Enterprises LRP-07, LES BAER .308, COLT LE 901-165, Armalite AR10-A, S&W M&P 10.



C-MAG 7.62MM Technical Data

AMMUNITION: NATO standard 7.62 x 51mm .308 caliber
CAPACITY: Variable, 1 to 100 rounds
FEED RATE: Variable, up to 1,000 rounds per minute
DIMENSIONS: 13.1 x 5.6 x 3.8 inches 333 x 142 x 96.5mm
WEIGHT: Empty: 5.0 lbs / 2.2 kg
STORAGE LOADED: Indefinite
MATERIALS: Main Components: Filled thermoplastic Minor Components: Non-corrosive steel; alloy

DESCRIPTION

The C-MAG magazine 7.62 consists of two main component assemblies:

- **Double Drum Housing**
- **Feed Clip Assembly.**

Feed Clip Assembly PMAG

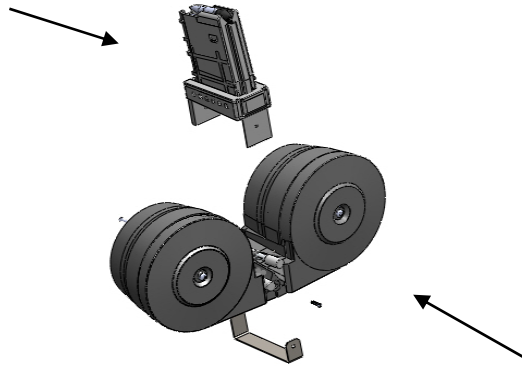

Double Drum Housing

The **double drum housing** comprises of:

- Double drum,
- Drive gear assemblies with pusher arms,
- Set of covers.

The housing acts as storage facility for the ammunition.

The **Feed Clip** is filled with **Two Strings of Linked Spacer Rounds:**

- 9-RD Linked Spacer Rd String (flat end)
- **9-RD** Linked Spacer Rd String (**tapered** end)

which occupy the feed clip when the magazine is empty. They are an integral part of the magazine assembly.

The **tapered end** of the string set is positioned at the open end of the feed clip when the magazine is empty and allows the weapon bolt to close after the last round has been fired.

WARNING: Do not remove the Linked
Spacer Round Strings !!

The bolt will stop in the closed position.

C-MAG **PMAG**

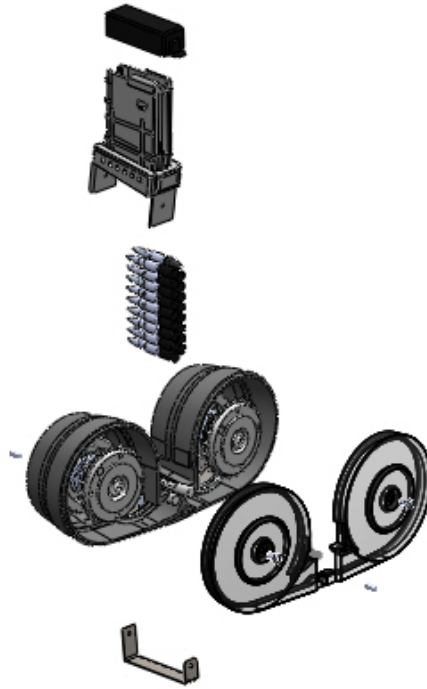

LOADING / LUBRICATION

- The C-MAG loads and functions like a standard issue magazine.
- Live cartridges are loaded by pressing them into the feed clip (on top of the spacer rounds). Cartridges will feed alternately into each drum. The springs are tensioned during the process without the need for any supplementary operations.
- The magazine does not need to be empty to be loaded and remains completely operational at all times.
- Load with the Personal Loader.
- Regularly **add Graphite** (dry lubricant).

Do not use Oil!



C-MAG Loading Action

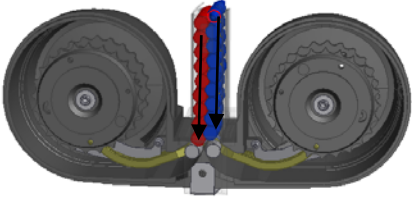

Rounds on the **left side of the feed clip** are loaded into the **left drum** and rounds on the **right side of the feed clip** are loaded into the **right drum**.

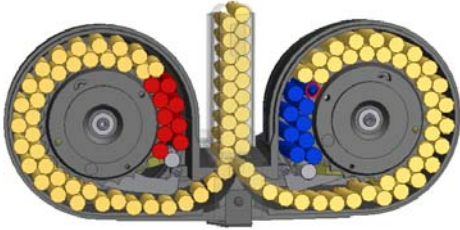

Use of the Personal Loader

The Personal Loader uses loose or bulk ammunition. It consists of two parts:

- **Housing**

Fits over the feed clip of the C-MAG.

- **Plunger**

Raise the plunger and insert 5 rounds into the side opening of the housing, depress plunger to load the rounds into the C-MAG.



DO NOT FORCE LOADING!

If extra force is required, **STOP**:

- Unload several rounds, push down to check rounds for free movement and reload.
- If rounds do not move freely and come up to the top of the feed clip, disassemble magazine and inspect.

CAUTION

PRECAUTIONARY MEASURES FOR USE IN SAND ENVIRONMENT

- Keep BOLT CLOSED when C-MAG is in the weapon.
- Keep DUST COVER on the feed clip whenever C-MAG IS NOT in the weapon.
- Keep C-MAG in Carrying Pouch when not in use.

DISASSEMBLY OF THE C-MAG

1. DISASSEMBLY FOR CLEANING

Take the empty C-MAG and

1.1. Remove Clip Assembly

- 1.1.a Remove clip screws, first front screw (drum side), than back screw (cover side).
- 1.1.b Turn C-MAG over and remove clip strap and feed clip assembly.
- 1.1.c Remove Linked Spacer Round String Set from feed clip.

1.2. Remove Cover Set

WARNING: Do not disassemble any further.

1.3. Cleaning

Clean drum assembly, covers, feed clip and linked string sets as recommended on next page.

CONTAMINATION & ACTION

HARSH SAND, DIRT ETC.:

Use cloth, compressed air or flush with water.

FINE SAND, SILT, MUD ETC.:

Soak in water with detergent (optional) to saturate and dissolve deposits. Flush with clean water.

OILS, GREASE, RESIDUES FROM SOLVENTS OR FUELS:

Use acetone or alcohol. Do not use oily fuels such as diesel, mineral spirits or kerosene. Follow up with detergent and water.

SALT DEPOSITS FROM SEAWATER:

Light deposits: Soak in water to dissolve.
Heavy deposits: Return to manufacturer.

CLEANING CLEAR COVERS:

DO NOT use any type of solvent on clear covers.
Clear Covers will turn cloudy! Clean with water, soap or detergent.

CAUTION

2. DISASSEMBLY FOR CLEARING OF BLOCKAGES

2.1. Remove Clip Assembly

HOLD DOWN clip assembly while removing screws and clip strap. Remove front screw first (drum side).

Point C-MAG away from you.

Removing the clip strap may release blockage. Cartridges may be forced out of the drum housing through the clip opening. Point away from you and control release of rounds by holding down clip.

2.2. Remove Cover Set.

Put C-MAG in container to avoid uncontrolled release of rounds. Point away from you!

- 2.2.a Carefully remove screws and remove cover. Grasp and slowly rotate drive gear to dislodge ammunition. Shake drum assembly if necessary. Do not allow drive mechanism to snap back into place.
- 2.2.b Check for damaged parts.

2.3. Repairs

Magazines with obvious and serious damage to the drum assembly cannot be field repaired and must be returned to the manufacturer for repair.

Removable components are available as spare parts for field replacement.

C-MAG products can be returned to the manufacturer for warranty or post warranty work at any time.

THE BETA COMPANY

2137B Flintstone Drive, Tucker, GA 30084, USA
1-800-669-2382, www.betaco.com

ASSEMBLY OF THE C-MAG

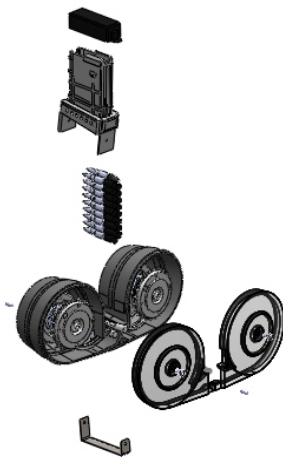

1. **Inspection**

All parts of the C-MAG should be inspected for function or damage prior to assembling. Drive gears in the double drum housing must rotate freely.

2. **Attach covers**

Place covers on drum assembly and attach. Covers are designed for a tight fit.

3. Attach feed clip assembly

3.1. Load feed clip

The feed clip holds two Linked-Spacer-Round-Strings.

- INVERT feed clip, legs pointing up.
- Align string sets vertically and nest together.

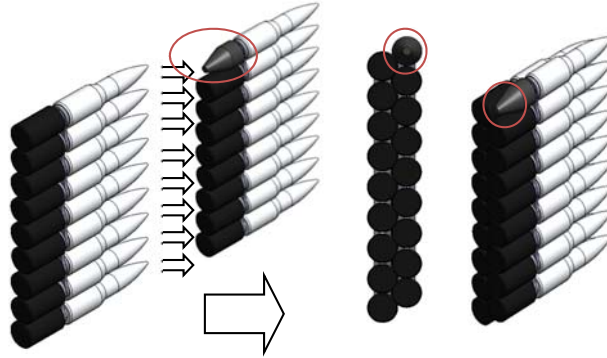

- Lower assembled string set into feed clip.

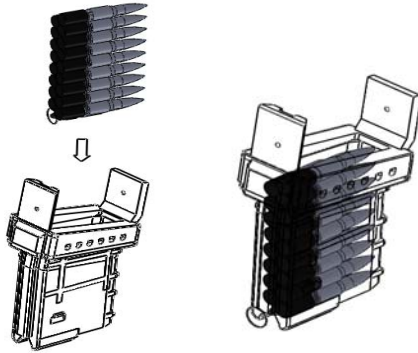

CAUTION:

TAPERED Round (circled) MUST be at the open end of the feed clip. The string set assembly must be installed vertically as shown.

DO NOT place linked string sets on top of each other. C-MAG will not load.

3.2. **Attach feed clip to drum housing**

- Invert double drum housing and feed clip assembly. Slide feed clip assembly on to drum housing.
- Add clip strap, attach back screw (over covers) first.
- Turn around holding down feed clip assembly and attach screws. Assembly is complete.
- Depress spacer rounds to check for free movement.
- Add graphite to top of string sets for lubrication.



TROUBLESHOOTING	
Characteristic	Cause / Remedy
Does not load.	Linked Spacer Round String Set is installed incorrectly.
Loading is very difficult.	Dirty magazine.
Round missed stagger 	Will feed and fire if it loaded easily. If loading required extra force, unload and load again.
One side of feed clip shows live rounds, other side spacer round string.	One drum hesitated feeding; sign of dirty magazine.
Weapon bolt drives spacer round string into front of feed clip.	Linked Spacer Rounds are installed incorrectly. Tapered round MUST be at top-opening of the feed clip.

TROUBLESHOOTING	
Characteristic	Cause
Linked assembly drags in feed clip.	Linked assemblies have become lengthened. May be pushed back together and re-used or exchanged.
Magazine falls out of weapon.	Magazine is not fully seated in weapon.
Weapon fires several rounds, then jams. Magazine feeds well by hand when out of the weapon.	Check for secure attachment between the feed clip and drum assembly.
C-MAG rattles when empty or full.	This is normal.

ACCESSORIES

1.1. **Personal Loader** (see Page 10)



1.2. **Pouch**

1.2.a the pouch is designed to hold

- 1 C-MAG Magazine
- 1 Loader
- 2 Graphite Tubes
- 1 User Manual

Pouch



See website @ www.betaco.com

C-MAG MAGAZINE SYSTEM PMAG

Includes the following components:

1 each C-MAG Magazine PMAG

1 each Personal Loader PMAG

1 each Pouch, Color: Black

1 each User Manual PMAG

2 each Graphite Tubes



LIST OF PART NUMBERS

Part No.	Description
-----------------	--------------------

M7PM021	C-MAG SYSTEM PMAG (clear covers)
---------	-------------------------------------

C7PM020	C-MAG Magazine PMAG (clear covers)
---------	---------------------------------------

LPM705	Personal Loader PMAG/AR10
PM1706	Pouch black

A7PM03	Feed Clip Kit PMAG
S7M102CL	Drum Back Cover Set clear 7.62
S7M160	Dust Cover 7.62
X7PMTEM	User Manual PMAG
XXXGT1	Graphite Tube

For further information contact:

THE BETA COMPANY
2137B Flintstone Drive, Tucker, Georgia 30084, USA

Phone: +770 270 0773 OR 1 800 669 2382

Fax: +770 270 0599

Internet: www.betaco.com

X7PMTEM, Rev.0