

# CX-10 Extreme

user manual

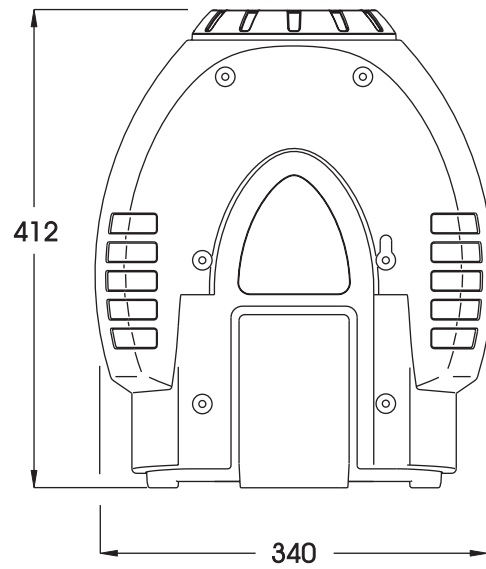

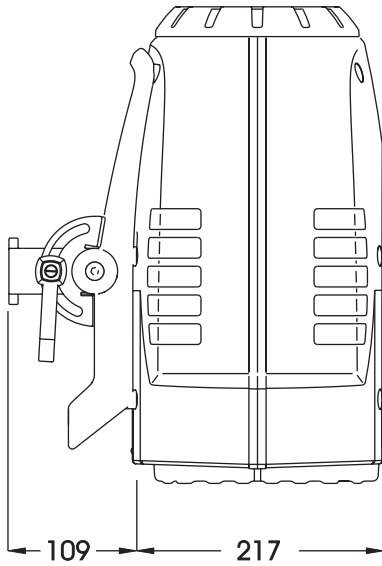
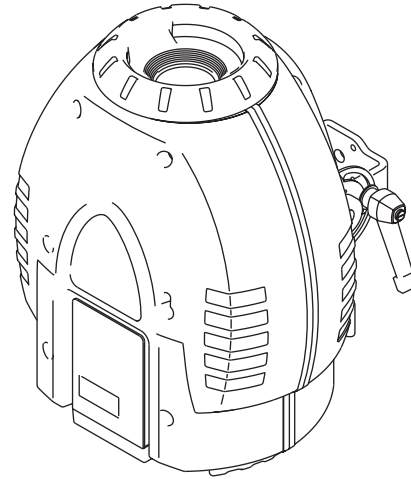
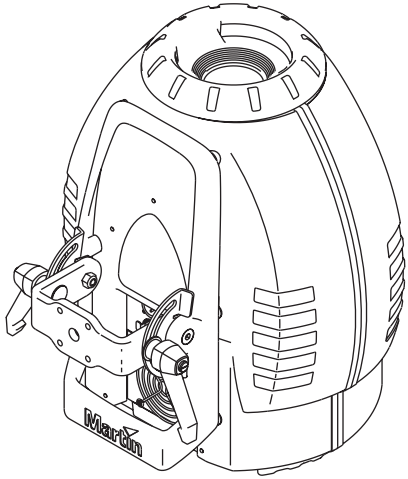

---

© 2004 Martin Professional A/S, Denmark.

All rights reserved. No part of this manual may be reproduced, in any form or by any means, without permission in writing from Martin Professional A/S, Denmark.

Printed in Denmark.

P/N 35000129, Rev. C

---

<b>Introduction</b> .....	<b>4</b>
Features .....	4
About this manual .....	4
<b>Safety</b> .....	<b>5</b>
Safety precautions .....	5
<b>Setup</b> .....	<b>6</b>
Unpacking .....	6
AC power .....	6
Installation .....	7
Connecting the serial data link .....	8
<b>Control Panel</b> .....	<b>9</b>
Menu navigation .....	9
Address selection .....	9
Tailoring performance .....	10
Information readouts .....	10
Test and service utilities .....	11
<b>DMX-512 control</b> .....	<b>13</b>
Lamp power .....	13
Effect position .....	13
Speed control .....	14
<b>Optical configuration</b> .....	<b>15</b>
Effect wheel .....	15
Color filters .....	18
Optional lenses .....	19
Animation wheels .....	22
<b>Service</b> .....	<b>28</b>
Lamp .....	28
Cleaning .....	29
Lubrication .....	30
Replacing fuses .....	30
Updating software .....	31
<b>DMX protocol</b> .....	<b>32</b>
<b>Control menu</b> .....	<b>34</b>
<b>Error messages</b> .....	<b>37</b>
<b>Troubleshooting</b> .....	<b>38</b>
<b>PCB connections</b> .....	<b>39</b>
<b>Specifications - CX-10</b> .....	<b>40</b>

# INTRODUCTION

## Features

Thank you for selecting the Martin CX-10 Extreme. Some of the many features include:

- efficient, 3000 hour, 250 watt discharge lamp
- 12 interchangeable dichroic colors plus open
- double-sided, 13-position, effect wheel which enables overlapping effects.
- motorized focus
- full-range dimming
- fast blackout and strobe effects
- coated optics
- switch-selectable power supply settings
- integrated mounting bracket
- easy-to-clean cooling fan
- optional wide and narrow angle lens kits available
- optional animation kit available

## About this manual

Please check the Martin web site at <http://www.martin.com> for the latest product software and documentation.

Comments or suggestions regarding this document may be e-mailed to [service@martin.com](mailto:service@martin.com) or sent by standard mail to:

Martin Professional A/S  
Olof Palmes Allé 18  
DK-8200 Aarhus N, Denmark  
Attn: Service Department

Please review the important safety precautions in this manual before installing and operating the fixture.

# SAFETY

**Warning!** *This product is for professional use only. It is not for household use.*

This product presents risks of lethal or severe injury due to fire and heat, electric shock, ultraviolet radiation, lamp explosion, and falls. **Read this manual** before powering or installing the fixture, follow the safety precautions listed below and observe all warnings in this manual and printed on the fixture. If you have questions about how to operate the fixture safely, please contact your Martin dealer or call the Martin 24-hour service hot line at +45 70 200 201.

## Safety precautions

### PROTECTION FROM ELECTRIC SHOCK

- Disconnect the fixture from AC power before removing or installing the lamp, fuses, or any part, and when not in use.
- Always ground (earth) the fixture electrically.
- Use only a source of AC power that complies with local building and electrical codes and has both overload and ground-fault protection.
- Do not expose the fixture to rain or moisture.
- Refer any service operation not described in this manual to a qualified technician.

### PROTECTION FROM UV RADIATION AND LAMP EXPLOSION

- Never operate the fixture with missing or damaged lenses and/or covers.
- When replacing the lamp, allow the fixture to cool for at least 15 minutes before opening the fixture or removing the lamp. Protect your hands and eyes with gloves and safety glasses.
- Do not stare directly into the light. Never look at an exposed lamp while it is lit.
- Replace the lamp if it becomes defective or worn out, or before usage exceeds the maximum service life.

### PROTECTION FROM BURNS AND FIRE

- Never attempt to bypass the thermostatic switch or fuses. Always replace defective fuses with ones of the specified type and rating.
- Keep all combustible materials (for example fabric, wood, paper) at least 0.1 meter (4 inches) away from the fixture. Keep flammable materials well away from the fixture.
- Do not illuminate surfaces within 0.3 meters (12 inches) of the fixture.
- Provide a minimum clearance of 0.1 meters (4 inches) around fans and air vents.
- Never place filters or other materials over the lens.
- The exterior of the fixture can get very hot. Allow the fixture to cool for at least 5 minutes before handling.
- Do not modify the fixture or install other than genuine Martin parts.
- Do not operate the fixture if the ambient temperature ( $T_a$ ) exceeds 40° C (104° F).

### PROTECTION FROM INJURY DUE TO FALLS

- When suspending the fixture, verify that the structure can hold at least 10 times the weight of all installed devices.
- Verify that all external covers and rigging hardware are securely fastened and use an approved means of secondary attachment such as a safety cable.
- Block access below the work area whenever installing or removing the fixture.

# SETUP

## Unpacking

The CX-10 comes with:

- MSD 250/2 lamp
- 3-meter, 3-wire IEC power cable
- user manual

The packing material is carefully designed to protect the fixture during shipment - always use it or a custom flight case to transport the fixture.

## AC power

**Warning!** For protection from electric shock, the fixture must be grounded (earthed). The power supply shall have overload and ground-fault protection.

**Important!** Verify that power supply settings match the local AC supply before use.

*The CX-10 is factory configured for 230 V / 50 Hz operation. If your AC power supply is different, the fixture must be configured for the local voltage and frequency. Always use the voltage settings that are equal to or next highest to your AC supply.*

### CONFIGURING FOR LOCAL AC POWER

- 1 Disconnect the fixture from power.

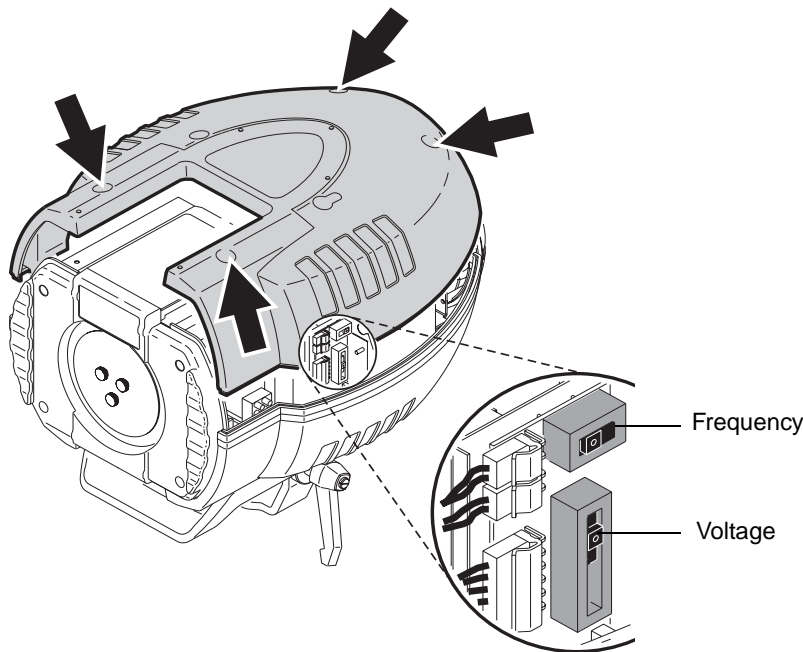

- 2 Remove the 4 cover screws and lift off the front cover.
- 3 Locate the selection switches and the settings label, which is by the color wheel. Move the voltage switch to the setting that is equal to or higher than the local AC voltage. If your voltage falls between 2 settings, always select the higher voltage. For example, if the AC voltage is 215 V, use the 230 V setting instead of 210 V.
- 4 Move the frequency switch to the setting that matches the local AC frequency: 50 or 60 Hz.
- 5 Replace the cover.

## INSTALLING A PLUG ON THE POWER CABLE

The power cable must be fitted with a grounding-type cord cap that fits your power distribution system. Consult an electrician if you have any doubts about proper installation.

- Following the cord cap manufacturer's instructions, connect the yellow and green wire to ground (earth), the brown wire to live, and the blue wire to neutral. The table below shows some pin identification schemes.

Wire	Pin	Marking	Screw color
brown	live	"L"	yellow or brass
blue	neutral	"N"	silver
yellow/green	ground		green

Table 1: Plug wiring

## APPLYING POWER

**Warning!** *The power cables must be undamaged and rated for the electrical requirements of all connected devices.*

**Important!** *Powering through a dimmer system can damage the fixture.*

- 1 Verify that the supply cable is undamaged and rated for the current requirements of all connected devices.
- 2 Plug the prepared power cable into the AC socket and a grounded AC power supply.

AC input & fuse holder  
Data input  
Data output

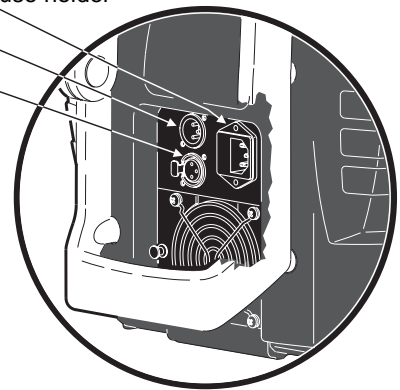

## Installation

### LOCATION AND ORIENTATION

The CX-10 may be installed in any orientation. It can be fastened directly to a suitable surface, hung with a rigging clamp, or placed directly on a level surface.

For safe operation, install the CX-10 in a location where

- the fixture is at least 0.1 meters (4 inches) away from combustible materials
- the fixture is protected from rain and moisture
- there is at least 0.1 meters (4 inches) clearance around the fan and control panel
- there are no flammable materials nearby

### RIGGING OR MOUNTING THE CX-10

**Warning!** *Block access below the work area before proceeding.*

**Warning!** *Always use a secure means of secondary attachment.*

- 1 If using a rigging clamp (not included), verify that it is undamaged and can bear at least 10 times the fixture's weight. Bolt the clamp securely to the bracket with a grade 8.8 (minimum) M12 bolt and lock nut, or as recommended by the clamp manufacturer, through the 13 mm hole in the center of the mounting bracket.
- 2 If fastening the fixture directly, verify that the hardware (not included) and mounting surface can bear at least 10 times the fixture's weight. The four 6.2 mm holes and/or the 13 mm hole in the mounting bracket may be used to fasten the fixtures.
- 3 Verify that the structure can support at least 10 times the weight of all installed fixtures, clamps, cables, auxiliary equipment, etc.
- 4 Working from a stable platform, clamp or fasten the fixture to the structure.

- 5 Install a safety cable that can hold at least 10 times the weight of the fixture through/over the support and anywhere through the fixture's aluminum frame.
- 6 Loosen the swivel locks and tilt the fixture to the desired angle. Turn the swivel locks clockwise to tighten. When a handle reaches its limit, pull it out, turn counterclockwise, release, and continue tightening.
- 7 Verify that the fixture meets the location requirements listed previously.

## Connecting the serial data link

The CX-10 has locking 3-pin data input and output sockets that are wired for use with DMX devices with pin 1 to shield, pin 2 to cold (-) and pin 3 to hot (+). As some devices have 5-pin connectors, or 3-pin connectors with reversed polarity on pins 2 and 3, the following adaptor cables may be required.

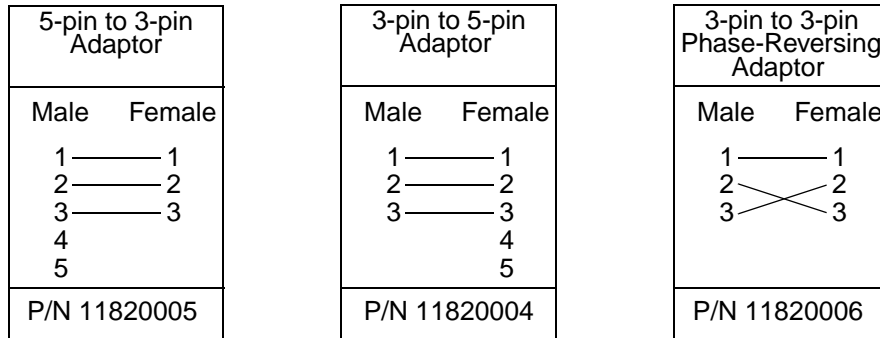

Figure 1: Cable adaptors

- 1 Connect the controller's output to the fixture's data input. For a DMX controller with 5-pin output, use a cable with a 5-pin male and a 3-pin female XLR connector.
- 2 Connect the output of the fixture closest to the controller to the input of the next fixture. If connecting a fixture with pin 3 hot to a fixture with pin 3 cold, use a phase-reversing adaptor.
- 3 To terminate the link, insert a male 120  $\Omega$  XLR termination plug in the output of the last fixture.

AC input & fuse holder

Data input

Data output

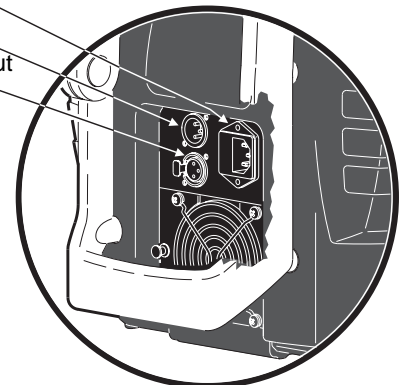

### TIPS FOR BUILDING A SERIAL LINK

- Use shielded twisted-pair cable designed for RS-485 devices: standard microphone cable cannot transmit DMX data reliably over long runs. For links up to 300 meters (1000 ft.) long, you can use 24 AWG, low capacitance, 85-150 ohm characteristic impedance, shielded cable with 1 or more twisted pairs. For runs up to 500 meters (1640 ft.) use 22 AWG cable. Use an amplifier if the serial link exceeds 500 meters.
- Never use a "Y" connector to split the link. To split the serial link into branches use a splitter such as the Martin 4-Channel Opto-Isolated RS-485 Splitter/Amplifier.
- Do not overload the link. Up to 32 devices may be connected on a serial link.
- Terminate the link by installing a termination plug in the output socket of the last fixture on the link. The termination plug, which is simply a male XLR connector with a 120 ohm, 0.25 watt resistor soldered between pins 2 and 3, "soaks up" the control signal so it does not reflect back down the link and cause interference. If a splitter is used, terminate each branch of the link.



# CONTROL PANEL

You set the address and personalities, read out data, and execute service utilities from the control panel. Settings can also be changed remotely via the serial link with the Martin MP-2 uploader.

There are four small symbols that can appear in the control panel display:



Power is on and the fixture is ready.



The fixture is writing to memory. Do not power off the fixture while this symbol is lit.



The fixture is receiving DMX.



Error. See "Error messages" on page 37 and "Troubleshooting" on page 38.

## Menu navigation

See also the control menu table starting on page 34.

The DMX address and any error messages are displayed after the fixture resets. To enter the menu, press [menu]. Use the [up] and [down] keys to move within the menu. To select a function or submenu, press [enter]. To escape a function or menu, press [menu].

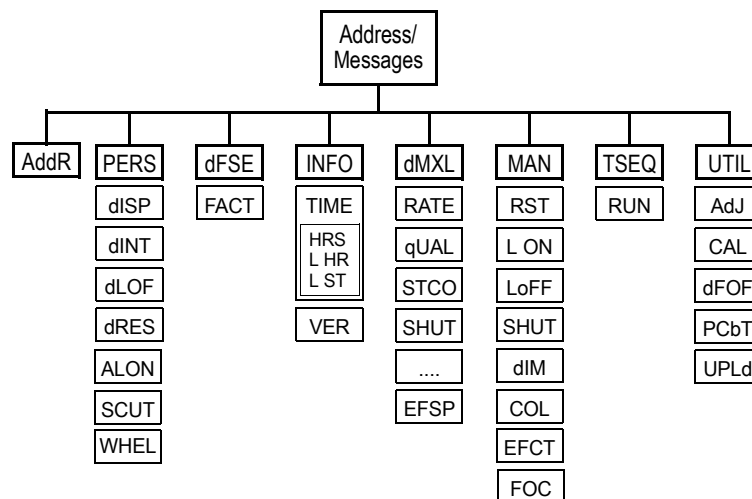

## Address selection

The CX-10 requires 10 channels for DMX control. The address, also known as the start channel, is the first channel used to receive instructions from the controller. For independent control, each fixture must be assigned its own address and non-overlapping control channels. Two CX-10s can share the same address

if they are to respond identically: they will receive the same instructions and individual control will not be possible.

### **TO SET THE DMX ADDRESS**

- 1 Apply power to the CX-10. Press [menu] to enter the main menu.
- 2 Select AddR using the [up] and [down] keys. Press [enter].
- 3 Select an address (start channel) from 1 to 502 using the [up] and [down] keys. Press [enter]. Press [menu] to return to the main menu.

## **Tailoring performance**

### **MOVEMENT**

SCUT, the shortcuts setting, determines whether the color and gobo wheels scroll past open when changing positions. When set to ON, the wheels can “take a shortcut” and scroll through open when this is the shortest path to the next position. The wheels do not scroll past open when SCUT is set to OFF.

### **DISPLAY**

The display menu (PERS>dISP) determines whether the display remains lit or not. Select ON to have the display remain lit, or OFF to extinguish the display two minutes after the last key press.

To flip the display for easier reading, press [up] and [down] simultaneously.

The display intensity setting (PERS>dINT) controls display brightness. You can select AUTO for automatic dimming of the display using the built-in light sensor, or manually select an intensity level from 10 to 100.

### **LAMP POWER**

There are two settings that modify lamp control: Automatic Lamp On (PERS>ALON) and DMX Lamp-Off (PERS>DLOF).

There are three options for automatic lamp control: ON, OFF, and DMX. When ALON is OFF, the lamp remains off until a lamp-on command is received from the controller. When ALON is ON, the lamp strikes automatically after the fixture is powered on. When ALON is set to DMX, the lamp strikes automatically when the fixture receives DMX data, and it extinguishes automatically 15 minutes after DMX data is lost. When ALON is either ON or DMX, lamp strike timing is determined by the fixture address to prevent all lamps from striking at once.

The DMX Lamp-Off setting effects how the lamp can be turned off. When dLOF is ON, lamp power can be switched off by sending a DMX value from 248 to 255 on channel 1 for five seconds. When dLOF is OFF, the lamp-off command will not work unless special conditions are met. Refer to the DMX protocol.

### **RESET**

The fixture can be reset from the controller if DMX reset (PERS>dRES) is ON. If DMX reset is OFF, this command will not work unless special conditions are met. Refer to the DMX protocol.

### **DEFAULT SETTINGS**

The fixture can be reset to its factory default settings by selecting dFSE>FACT>LOAD .

## **Information readouts**

### **POWER-ON HOURS**

Read the total number of hours the fixture has been on since fabrication (INFO>TIME>HRS>TOTL), and the number of hours on since the counter was last reset (INFO>TIME>HRS>RSET). This can be used to track maintenance intervals. Press [up] for 5 seconds while displayed to reset.

## LAMP HOURS

Read the total number of lamp hours since fabrication (`INFO>TIME>L HR>TOTL`), and the number of lamp hours since the counter was last reset (`INFO>TIME>L HR>RSET`). Reset this counter after installing a new lamp. Press [up] for 5 seconds while displayed to reset.

## LAMP STRIKES

Read the total number of lamp strikes (`INFO>TIME>L ST>TOTL`), and the number of lamps strikes since the counter was last reset (`INFO>TIME>L ST>RSET`). Reset this counter when installing a new lamp. Press [up] for 5 seconds while displayed to reset.

## FIRMWARE VERSION

`INFO>VER` displays the firmware version number. The firmware version is also displayed briefly at startup.

## Test and service utilities

### DMX READOUT

The DMX log (`dMXL`) menu provides useful information for troubleshooting control problems.

`RATE` displays the DMX refresh rate in packets per second. Values lower than 10 or higher than 44 may result in erratic performance, especially when using tracking control.

`QUAL` displays the quality of the received DMX data as a percentage of packets received. Values much below 100 indicate interference, poor connections, or other problems with the serial data link that are the most common cause of control problems.

`STCO` displays the DMX start code. Packets with a start code other than 0 may cause irregular performance.

The remaining options under `dMXL` display the DMX values received on each of the channels, from `SHUT` (shutter, channel 1) to `EFSP` (effect speed, channel 10). If the fixture does not behave as expected, reading the DMX values can help you troubleshoot the problem.

### MANUAL CONTROL

The manual control menu (`MAN`) provides commands for turning the lamp on (`LON`), turning the lamp off (`LOFF`), and resetting the fixture (`RST`). It also permits you to position and move individual effects.

### EFFECTS TEST

The test sequence (`TSEQ>RUN`) runs through all effects to provide a quick check of fixture performance. Note: the test sequence does not automatically strike the lamp. Use `MAN>LON` and `MAN>LOFF` to control lamp power. Press [menu] to stop the test.

### ADJUSTMENT POSITIONS

The adjustment menu (`UTIL>AdJ`) provides commands for positioning effects during mechanical adjustment.

### EFFECT CALIBRATION

With the calibration menu (`UTIL>CAL`), effect positions can be fine-tuned with a software-defined offset value to compensate for small misalignments or differences between fixtures.

The default offset command (`UTIL>dFOF`) erases any offsets stored in memory.

### CIRCUIT BOARD TEST

`UTIL>PCBT` executes a routine designed for testing the main circuit board. For service use only.

## **UPLOAD MODE**

The upload mode command (`UTIL>UPLd`) prepares the fixture for a software update. This command is not necessary, however, as upload mode is engaged automatically by the uploader.

# DMX-512 CONTROL

This section briefly describes the DMX-controllable effects. See also the DMX table starting on page 32 and the DMX chart on the back cover.

## Lamp power

### LAMP-ON

Unless automatic lamp strike is enabled, lamp power remains off until a lamp-on command is sent from the controller.

Note: A peak of electric current that can be many times the operating current is drawn for an instant when striking a discharge lamp. Striking many lamps at once may cause a voltage drop large enough to prevent lamps from striking or draw enough current to trip circuit breakers. If sending lamp-on commands to multiple fixtures, program a sequence that strikes lamps one at a time at 5 second intervals.

### LAMP-OFF

The lamp can be turned off from the controller by sending the lamp-off command on channel 1 for 5 seconds. ***The lamp cannot be restruck for 8 minutes after being turned off.*** Note that the lamp-off command may be disabled by the DMX Lamp-Off personality setting.

## Effect position

### RESET

If an effect loses its indexing and fails to move to programmed positions, the fixture can be reset from the controller by sending the "Reset" command on channel 1 for 5 seconds. Note that the DMX reset feature may be disabled by the DMX Reset personality setting.

### DIMMER / SHUTTER

The mechanical dimmer/shutter system provides full, high-resolution dimming, "instant" open and blackout, random and variable strobe effects, and random and variable pulses in which the dimmer snaps open and slowly dims or snaps closed and slowly opens. Shutter, strobe, and pulse effects are selected on channel 1. The intensity level is selected on channel 2.

### COLOR

The 13 color wheel positions can be selected on channel 3. The color wheel can be scrolled continuously - allowing for split color effects - or in steps, and rotated randomly or continuously in both directions at different speeds (set on channel 5).

### EFFECT WHEEL

The 13 positions on the effect wheel can be selected on channel 4.

The effect wheel also rotates continuously in both directions at variable speed (set on channel 6).

### FROST FILTER

The frost filter is selected on channel 7.

### FOCUS

The beam may be focused from approximately 2 meters (6.5 feet) to infinity using channel 8.

## Speed control

### **TRACKING CONTROL**

Tracking control is enabled by setting the Effects speed channel (10) to 0.

With tracking control, the speed at which effects move is determined by the cross-fade time between two positions or scenes. The controller divides the move into steps and updates the fixture with small changes at the rate required to achieve the fade. The fixture “tracks” the changes and averages them with a digital filter algorithm to provide smooth movement.

### **VECTOR CONTROL**

With vector control, movement speed is determined by the speed values on channel 10. This provides a way to control speed on controllers without cross-faders. Vector control also provides smoother movement, particularly at slow speeds, with controllers that send slow or irregular tracking updates.

When using vector control, the cross-fade time must be 0.

### **BLACKOUT**

When “blackout while moving” is selected on channel 10, the shutter closes when the effect moves to make the transition invisible. The shutter opens when the movement is complete.

### **PERSONALITY OVERRIDES**

Channel 10 provides tracking values that allow you to override the shortcuts setting. See the DMX table for details.

# OPTICAL CONFIGURATION

This chapter contains the following sections:

- Effect wheel
- “Color filters” on page 18
- “Optional lenses” on page 19
- “Animation wheels” on page 22

## Effect wheel

The CX-10 contains a double-sided effect wheel which enables two effects to be combined at each of the 13 positions. This enables gobos and other effects to be combined. Effects are mounted on effect flags.

Effects that require a sharp focus should be placed on the lamp side of the effect wheel.

### STANDARD EFFECT WHEEL CONFIGURATIONS

#### Front-lens-side effect wheel positions

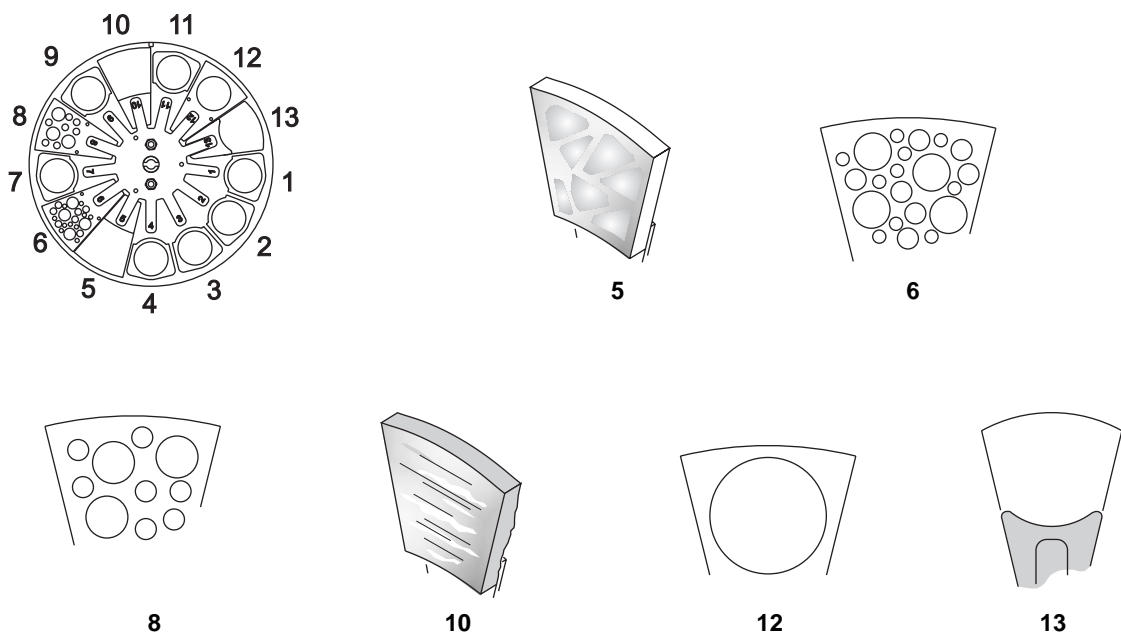

### Lamp-side effect wheel positions

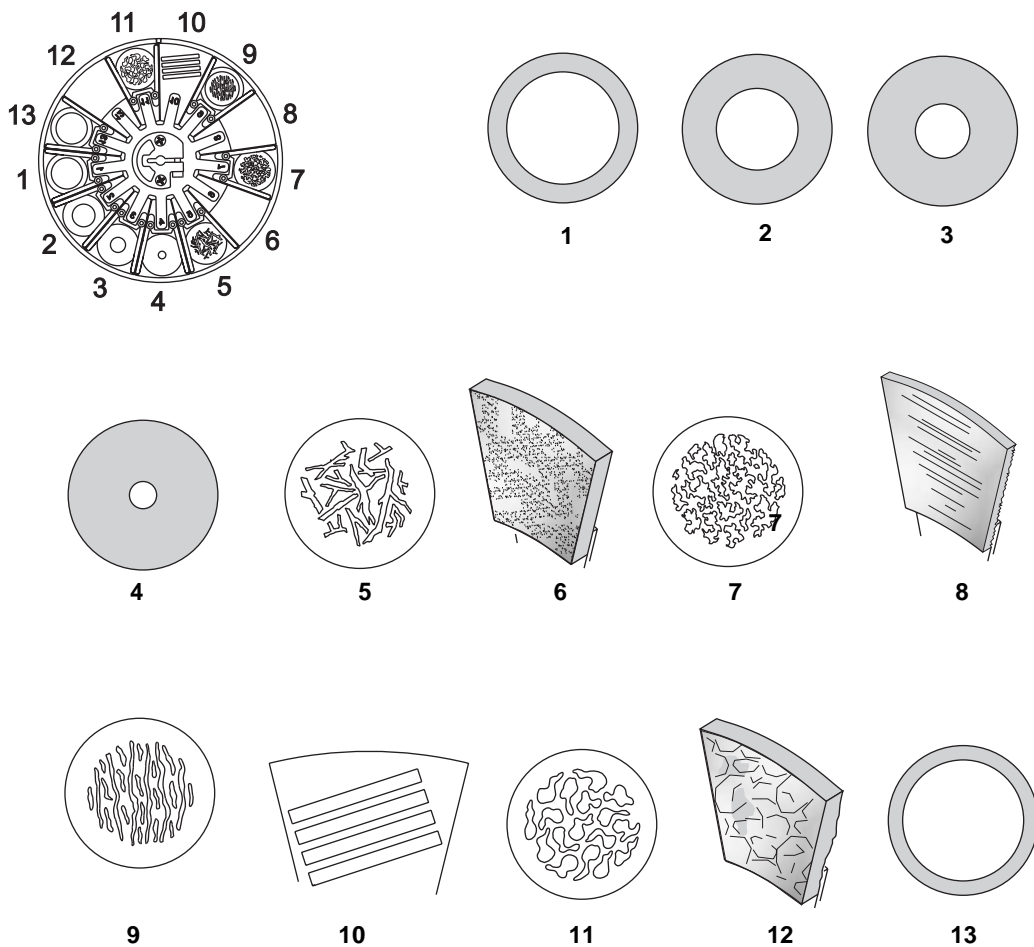

Position	Lamp-side effect wheel	Front-lens-side effect wheel	Combined effect
1	Open gobo, +22,5/17 HT-painted		
2	Gobo with 12 mm hole		
3	Gobo with 8 mm hole		
4	Gobo with 4 mm hole		
5	Forrest Floor	Small arctic textured glass	
6	Concrete flag textured glass	Punched twinkle A	"Golf balls" effect
7	Leaf breakup		
8	Fibroid textured glass	Punched twinkle B	"Fibroid twinkle"
9	Linear break-up		
10	Punched rectangular. effect	Large textured glass	"Bamboo" effect
11	Cell breakup		
12	Limbo flag textured glass	Punched aperture 18 mm	
13	Open gobo, +22,5/17 HT-painted	Color temperature correction 5500-2900K	



## REPLACING AN EFFECT FLAG

- 1 Disconnect the fixture from AC power and allow it to cool.
- 2 Remove the cover.
- 3 Turn the effect wheel to access the desired position. Press the effect flag forwards slightly to release it and then grasp it by the edges and remove.
- 4 To insert an effect flag, slide it under the retention spring until it snaps into place.
- 5 Replace the cover before applying power.

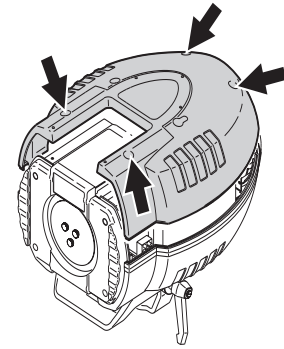

## GOBO ORIENTATION

Figure 2 shows the correct orientation for different gobo types. When in doubt, install gobos with the more reflective side towards the lamp.

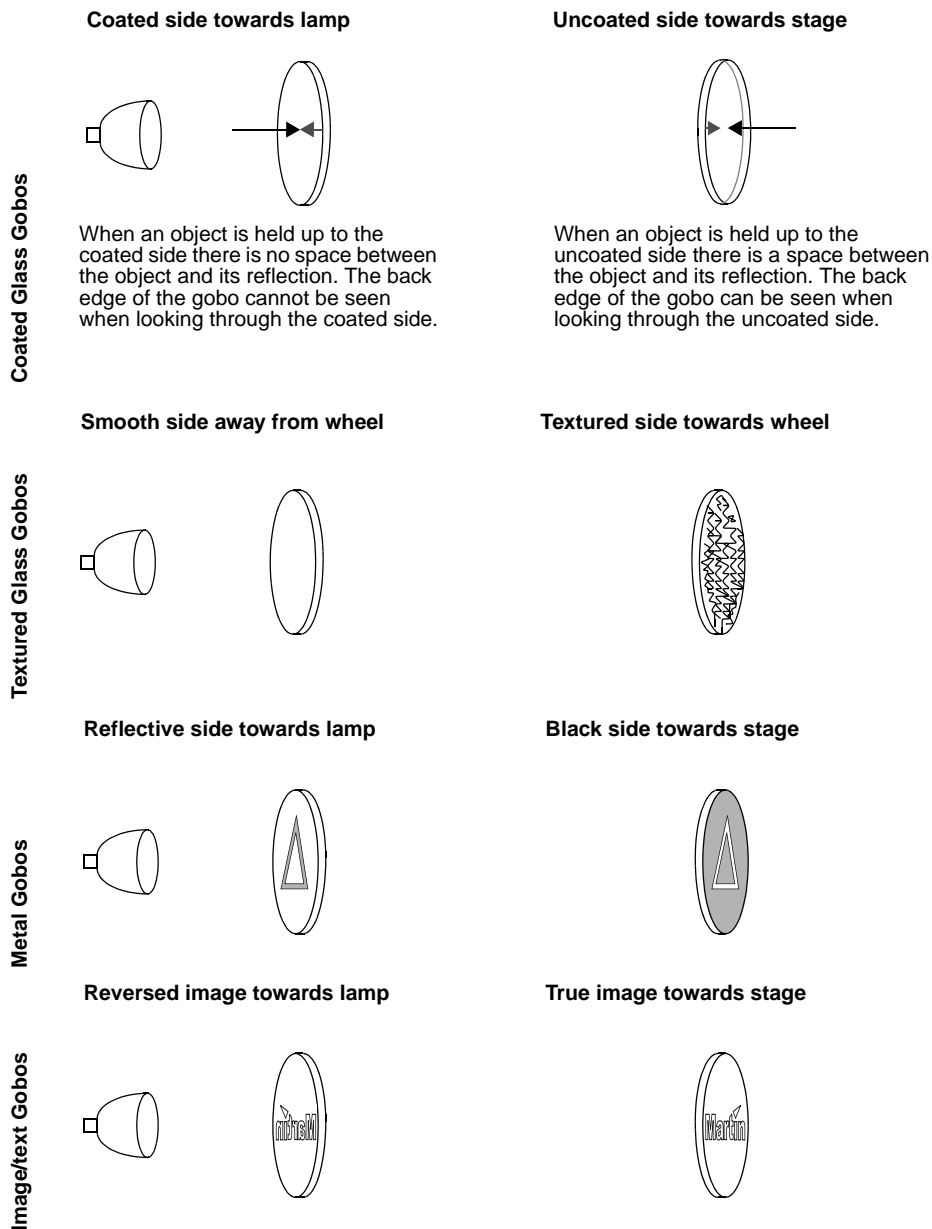

Figure 2: Gobo orientation

## Color filters

### STANDARD CONFIGURATION

The CX-10 provides 12 dichroic color filters as shown below.

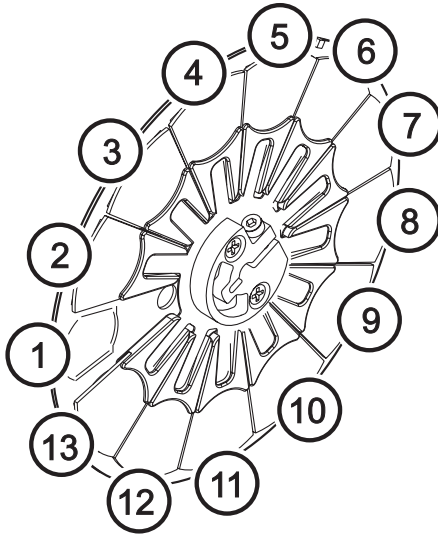
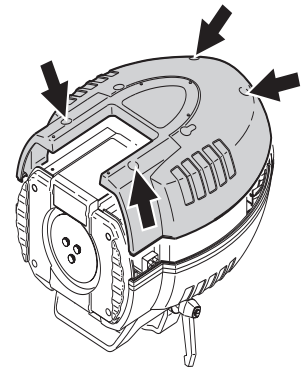
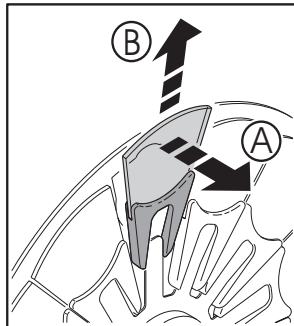

Figure 5: CX-10 color wheel

Position	Color
1	Open
2	UV transmitter
3	Yellow 603
4	Blue 104
5	Pink 312
6	Green 206
7	Blue 108
8	Red 301
9	Magenta 507
10	Blue 101
11	Orange 306
12	Dark green
13	Purple 502

### REPLACING A COLOR FILTER

- 1 Disconnect the fixture from AC power and allow it to cool.
- 2 Remove the fixture cover.
- 3 Turn the color wheel to access the desired color filter. Press the filter forwards slightly to release it and then grasp it by the edges and remove.



- 4 To insert a filter, slide it under the retention spring until it snaps into place.
- 5 Replace the fixture cover.

## Optional lenses

The standard 22 degree lens can be changed to 14 or 32 degrees using two separately orderable lens kits. See Accessories on page 41 for part numbers.

### CHANGING THE LENS

- 1 Disconnect the fixture from AC power and allow it to cool.
- 2 Remove the fixture cover.
- 3 Using a Phillips screwdriver, remove the focus module.

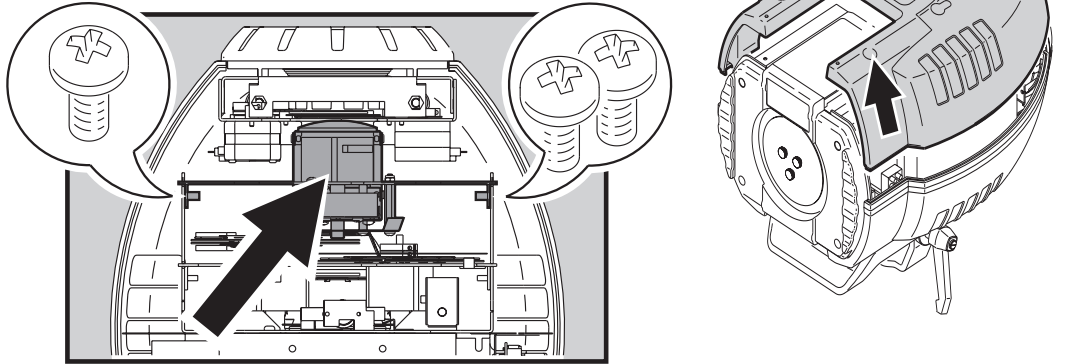

- 4 Using a Phillips screwdriver, remove the two screws from the focus module that hold the lens assembly in place.

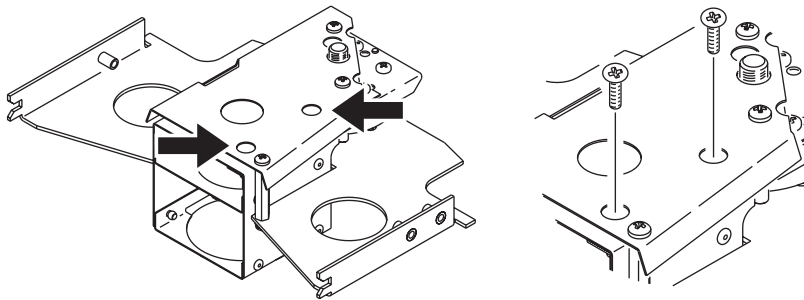

- 5 Slide the lens assembly out of the focus module.

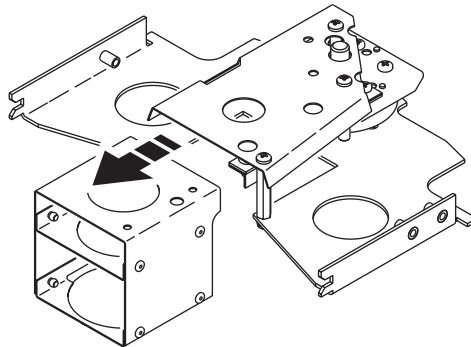

- 6 Slide the replacement lens assembly in to the focus module and secure it using the two Phillips screws.
- 7 If you are installing the narrow-angle lens kit (14° beam angle) then you need to change the glass. Remove the dimmer module so that you can access the front glass module. Remove the front glass module and

replace the standard front glass with the glass lens supplied in the narrow-angle lens kit. Replace the front glass module.

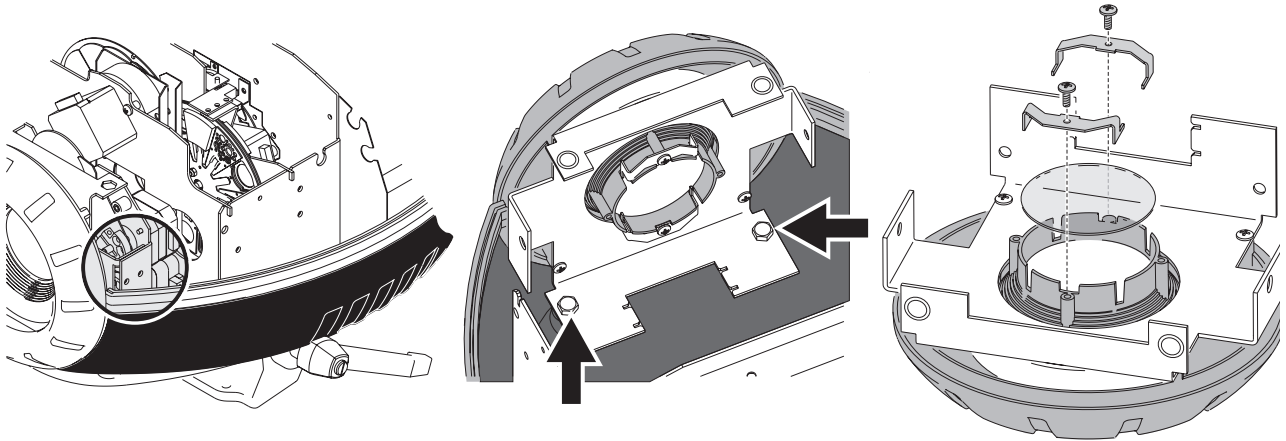

Dimmer module

Front glass module

Front glass replacement

8 Ensure that the dimmer module is installed in the appropriate position.

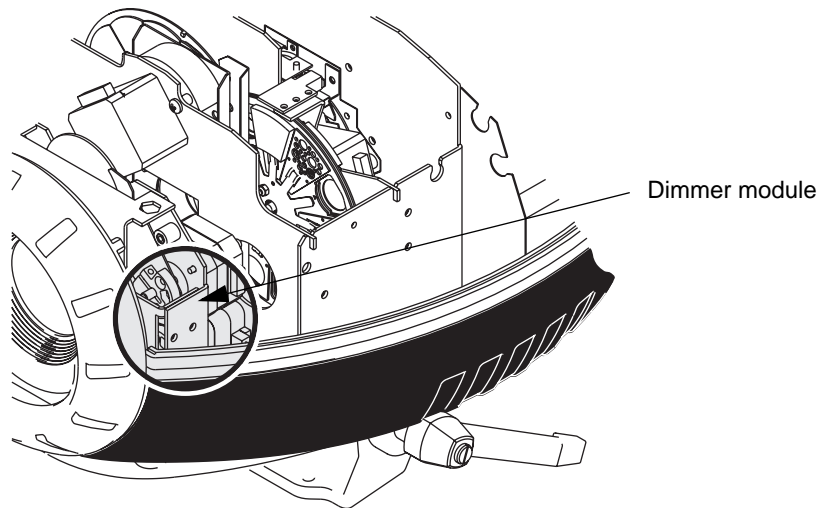

Dimmer module

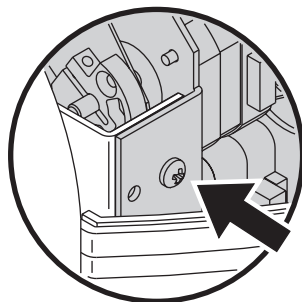

Standard and narrow angle lens position

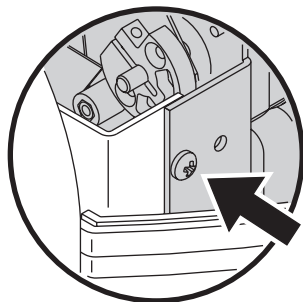
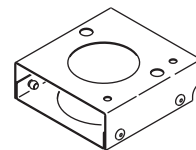

Wide angle lens position

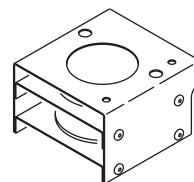

9 Using a Phillips screwdriver, replace the focus module.

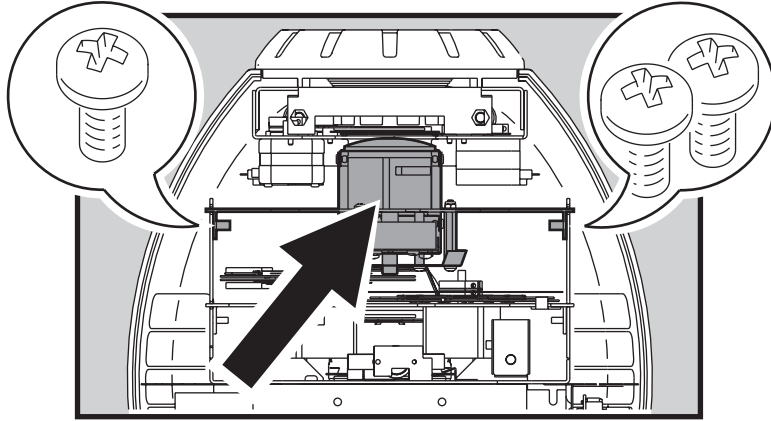

10 Replace the fixture cover before applying power.

## Animation wheels

An animation wheel can replace, or be affixed to the color wheel. This requires an Animation Wheel Adaptor Kit and an animation disc (see “Accessories” on page 41).

For a list of currently available animation wheels and tips on what effects are possible, see “Animation wheels and their uses” below. To achieve many effects you will use both an animation wheel and a regular gobo (and potentially a color filter) installed on the effect wheel.

To install an animation wheel, see:

- “Affixing an animation wheel to the color wheel” on page 24, below, or
- “Replacing the color wheel with an animation wheel” on page 26

### ANIMATION WHEELS AND THEIR USES

The animation wheels mentioned here can be ordered from your Martin dealer. The effects described are merely suggestions and a degree of experimentation may be required to achieve exactly the effect that you want to achieve. You may need to align the whole fixture along another plane in order to achieve animated vertical or horizontal motion.

**Tangential breakup:** The Tangential Breakup disc (P/N 62400215) produces a subtle rippling motion, particularly when moving parallel with the lines of the gobo. It is the most suitable for rising flames, flowing water and other effects where a single direction of movement is required.



**Radial breakup:** The Radial Breakup disc (P/N 62400211) is perfect for providing a strong regular movement suitable for flickering flames, water ripples, reflected water and shimmers for heat haze or mirage effects.

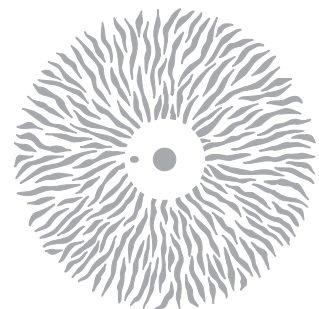

**Spiral breakup:** The Spiral Breakup disc (P/N 62400216) pattern is very similar to the Radial Breakup disc, but has some movement at right angles to the main motion, as is seen in wind blown rain, snow, or flames. It is particularly worth experimenting with the angle of the gobo and the orientation of the fixture to achieve all the possibilities with this pattern.



**Linear breakup:** The Linear Breakup disc (P/N 62400223) provides rhythmic movement and can be used to simulate a breeze through the branches of a tree or the rhythmic undulations of sea waves.

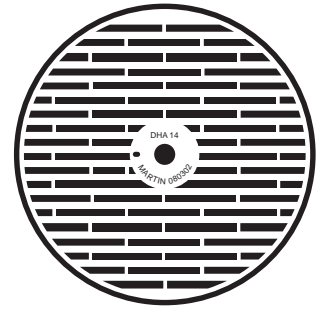

**Triangle breakup:** The Triangle Breakup disc (P/N 62400225) gives a more pronounced and rapid rhythmic effect than the Linear Breakup disc, and is suitable for use as psychedelic effects or for a rough sea effect.



**Cloud breakup:** The Cloud Breakup disc (P/N 62400213) is designed for a softer directional movement particularly at slow or very slow speeds. It is suitable for cloud effects with cloud gobos or for a soft slow-flowing stream effect.

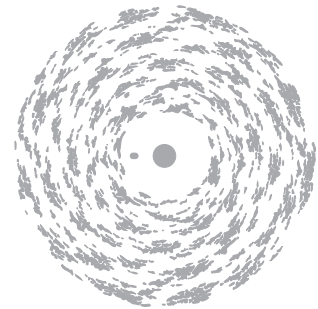

**Elliptical breakup:** The Elliptical Breakup disc (P/N 62400221) produces a bidirectional movement similar to the Spiral Breakup, but with constantly changing direction of movement. This is specifically useful for snow or similar effects where flurries of movement would be expected.



**Dot breakup:** The Dot Breakup disc (P/N 62400214) gives you the opportunity to cause motion while maintaining a more focused projection of the gobo image. It is suggested for effects such as falling leaves or rising bubbles.

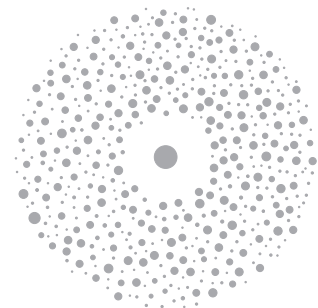

**Flicker wheel:** The Flicker Wheel (P/N 62400222) provides a different kind of effect and can be used at high speed for motion effects, such as passing trains. It can also be effectively used for just breaking up the beam of a fixture and for an organic strobe effect.

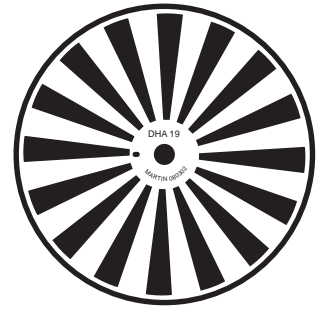

**Coarse radial breakup:** The Coarse Radial Breakup disc (P/N 62400224) is particularly effective for animating light from a non-focused source whilst providing a minimal loss in intensity due to the high 'white to black' ratio of the radial pattern. It is also effective for similar uses to the Radial Breakup disc.

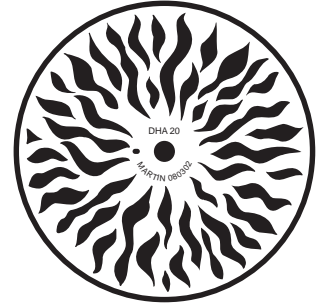

**Coarse tangential breakup:** The Coarse Tangential Breakup disc (P/N 62400226) can be used on its own in an unfocused form to give the image of flames. It can also be combined with gobos to give a drifting image to the projection.



## AFFIXING AN ANIMATION WHEEL TO THE COLOR WHEEL

To affix an animation wheel to the color wheel:

- 1 Using the control menu (see "Control menu" on page 34), select the wheel (WHEL) personality (under the PERS menu) and set it to EFCT. If you fail to do this an error will occur when the fixture resets.
- 2 Disconnect the fixture from AC power and allow it to cool.
- 3 Remove the fixture cover.
- 4 Using a Phillips screwdriver, remove the effect wheel module.

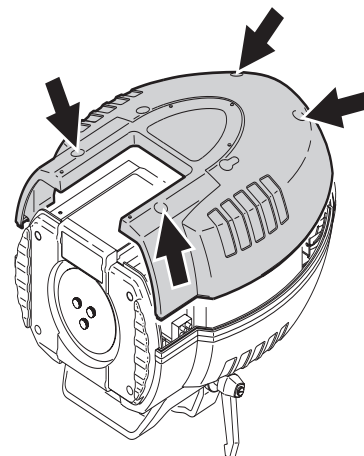
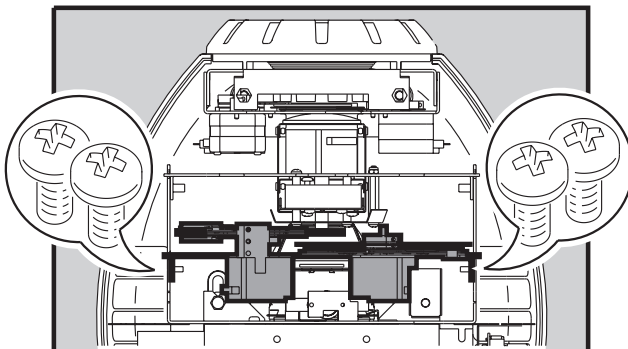



- 5 Remove the effects wheel and then the color wheel using a 2.5 mm hex wrench. The wheels are held in place using clamps that are similar to the one illustrated here.
- 6 Bearing in mind that in this configuration the animation wheel and the color wheel will rotate constantly, remove or replace any color flags as appropriate to the effect that you want to achieve. Note that you can move color flags to the effect wheel if necessary.
- 7 Modify the color wheel with the parts supplied in the Animation Wheel Kit as shown in the following illustration.

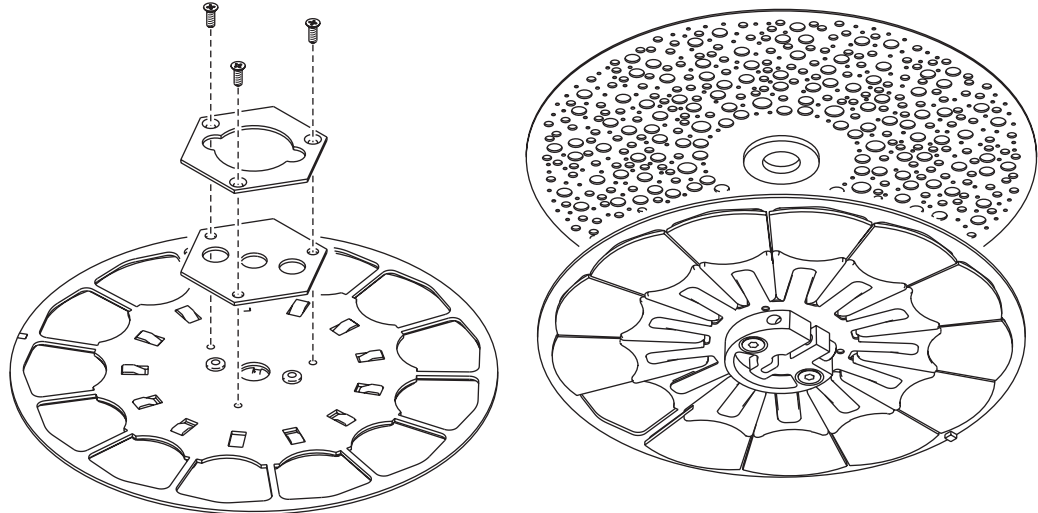
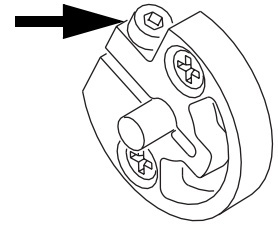

- 8 Place the animation wheel on the color wheel. It is held in place magnetically.
- 9 Place the combined color/animation wheel back on the motor spindle with the animation wheel closest to the lamp/effect motor. Ensure that the animation wheel is as close as possible to the effect-wheel-module bulkhead without it coming in contact with anything that might hinder its free rotation. The closer the animation wheel is to the bulkhead, the sharper you will be able to focus on it. Clamp the color wheel into place using a 2.5 mm hex wrench.
- 10 Replace the effects wheel, ensuring that it will sit as close to the focus module as possible. The optimal distance from the effects module bulkhead to the effect wheel is 15 mm (0.6 in.), but ensure that the wheel does not come into contact with anything that might hinder its free rotation. Clamp the effects wheel into place using a 2.5 mm hex wrench.

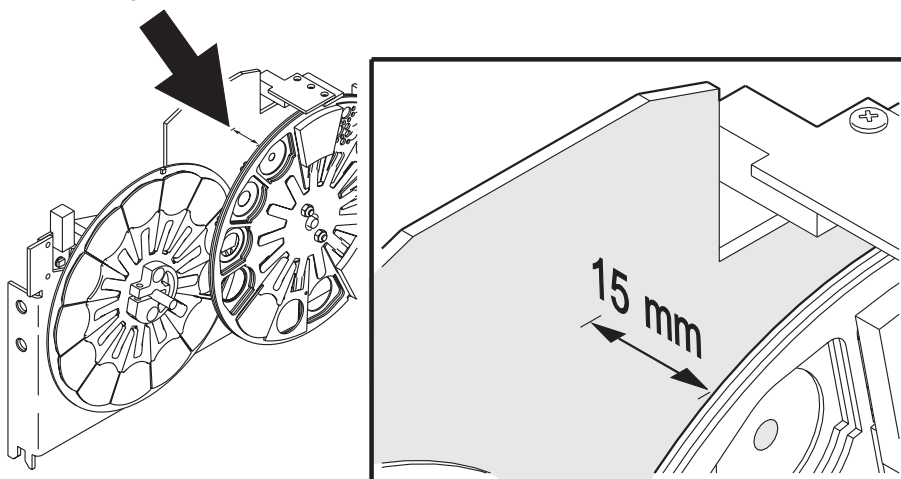

- 11 Replace the effect wheels module.
- 12 Replace the fixture cover before powering the fixture on.
- 13 If the effect wheel needs to be recalibrated, use the use the control menu to select UTIL>CAL>GoOf, where you can fine-tune the effect wheel position with a software-defined offset

**Note:** *If at a later time you remove the animation wheel then use the control menu to select the wheel (WHEL) personality (under the PERS menu) and set it to COLR. When you reinstall the color wheel you may also need to calibrate it using the color wheel calibration option available under the Utility menu. See “Control menu” on page 34 for more information.*

## REPLACING THE COLOR WHEEL WITH AN ANIMATION WHEEL

To replace the color wheel with an animation wheel:

- 1 Using the control menu (see “Control menu” on page 34), select the wheel (WHEL) personality (under the PERS menu) and set it to EFCT. If you fail to do this an error will occur when the fixture resets.
- 2 Disconnect the fixture from AC power and allow it to cool.
- 3 Remove the fixture cover.
- 4 Using a Phillips screwdriver, remove the effect wheel module.

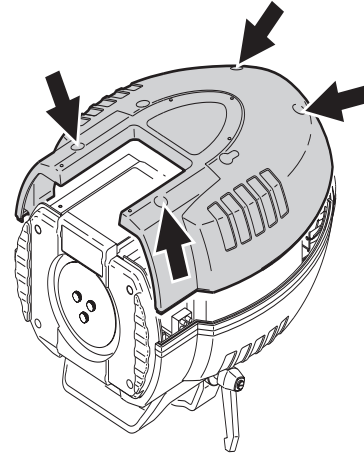
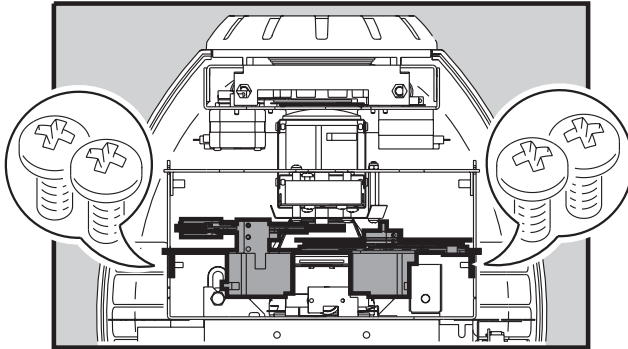

- 5 Remove the effects wheel and then the color wheel using a 2.5 mm hex wrench. The wheels are held in place using clamps that are similar to the one illustrated here.
- 6 If you want to use color effects then the appropriate color filters must be placed on the effect wheel.
- 7 A clamp with a magnet attached to it is supplied with the Animation Wheel Adaptor Kit. Place the animation wheel on the clamp. It will be held in place magnetically.

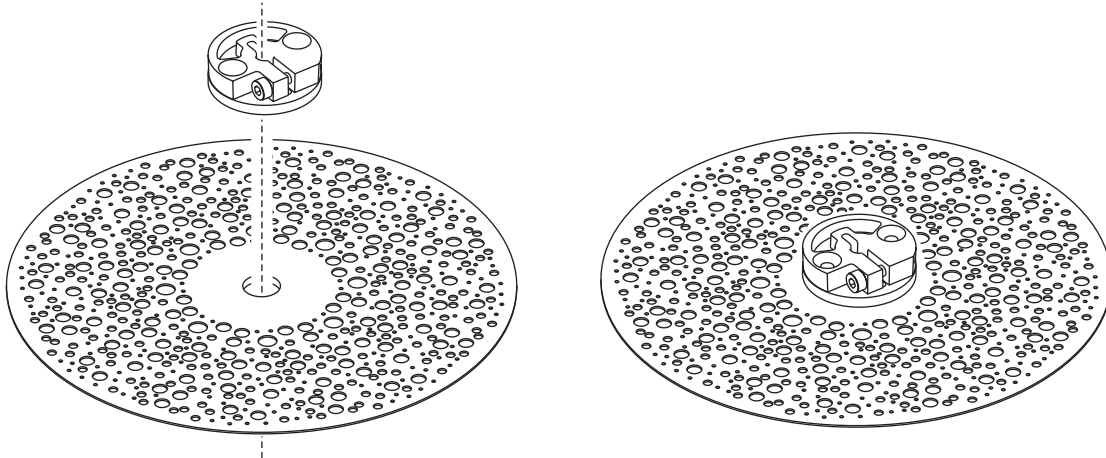
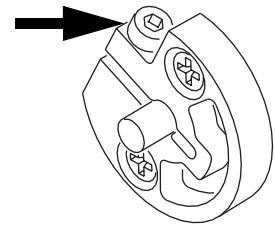

- 8 Place the animation wheel on the motor spindle with the magnetic clamp farthest from the lamp/effect motor. Ensure that the animation wheel is as close as possible to the effect-wheel-module bulkhead without it coming in contact with anything that might hinder its free rotation. The closer the animation wheel is to the bulkhead, the sharper you will be able to focus on it. Clamp the animation wheel into place using a 2.5 mm hex wrench.
- 9 Replace the effects wheel, ensuring that it will sit as close to the focus module as possible. The optimal distance from the effects module bulkhead to the effect wheel is 15 mm (0.6 in.), but

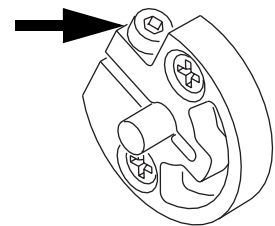

ensure that the wheel does not come into contact with anything that might hinder its free rotation. Clamp the effects wheel into place using a 2.5 mm hex wrench.

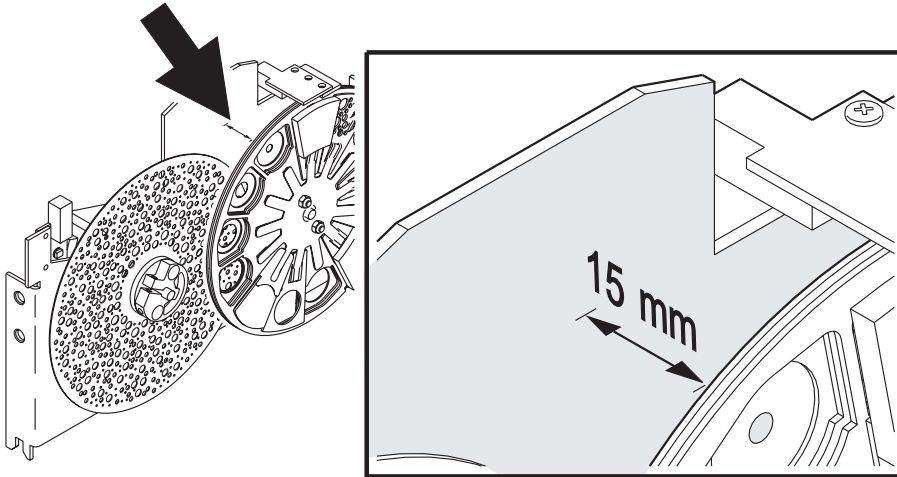

- 10 Replace the effect wheels module.
- 11 Replace the fixture cover before powering the fixture on.
- 12 If the effect wheel needs to be recalibrated, use the use the control menu to select UTIL>CAL>GoOf, where you can fine-tune the effect wheel position with a software-defined offset

**Note:** *If at a later time you remove the animation wheel and reinstall the color wheel then use the control menu to select the wheel (WHEL) personality (under the PERS menu) and set it to COLR. You may also need to recalibrate the color wheel using the color wheel calibration option available under the Utility menu. See “Control menu” on page 34 for more information.*

# SERVICE

The CX-10 requires regular maintenance to keep performing at their peak. Excessive dust, grease, and smoke fluid buildup degrades performance and causes overheating and damage that is not covered by the warranty. The maintenance schedule will depend on the application and should be discussed with your Martin distributor. Refer any service that is not described here to a professional technician.

**Warning!** *Removing covers while the fixture is powered on exposes dangerous live electrical circuits, hot surfaces, and a lamp under high pressure. Disconnect the fixture from AC power and allow it to cool before removing any cover.*

## Lamp

Lamp life will vary; the rated life is an average figure that is based on the manufacturer's test cycle. For maximum lamp life, avoid excessive strikes and always allow the lamp to burn for at least 5 minutes before turning it off.

To reduce the risk of lamp explosion, which may damage the fixture, never exceed the lamp's rated life (3000 hours) by more than 25 percent.

Replace the lamp when:

- it strikes with difficulty or not at all, or is in any other way defective
- usage exceeds the manufacturer's "replace before" hours. See Table 3.

### COMPATIBLE LAMPS

A Philips MSD 250/2 lamp is included. The CX-10 lamp options are shown in the table below. *Installing any other lamp may damage the fixture.*

Lamp	Average life	Color Temp.	Output	P/N
Osram HSD 250	2000 hr	6000K	68 lm/W	97010103
Philips MSD 250/2	3000 hr	8500K	72 lm/W	97010100
Philips MSD 200	2000 hr	5600K	67 lm/W	97010106

Table 3: Lamp comparison

## INSTALLING A LAMP

**WARNING!** *When replacing the lamp, disconnect the fixture from AC power and allow the lamp to cool for at least 15 minutes before proceeding. Wear safety goggles to protect your eyes.*

- 1 Remove the 2 screws labelled "Lamp replacement" and pull out the lamp socket.
- 2 If changing the lamp, remove the old lamp from the socket.
- 3 Pre-adjust the lamp socket by turning the 3 lamp adjustment screws to the middle of their range. There should be 2 mm (5/64ths of an inch) between each cap nut and the fixed disk.
- 4 Holding the new lamp by its ceramic base (do not touch the glass), align the small pin on the lamp with the small hole in the socket and insert the lamp squarely. Make sure that the 4 small projections on the base contact the face of the socket.
- 5 Clean the glass bulb with the cloth supplied with the lamp, particularly if your fingers touched the glass. A clean, lint-free cloth moistened with alcohol may also be used.
- 6 Insert the tip of the lamp into the fixture with as little twist in the lamp wires as possible. When the base of the lamp is inside the fixture, turn the lamp assembly so that the arrow points towards the control panel. Carefully locate the reflector opening, which is deep within the lamp chamber, and fully insert the lamp.
- 7 Align the screw holes and fasten the lamp access plate with 2 screws.
- 8 If replacing the lamp, reset the lamp hour and lamp strike counters as described on page 11.
- 9 Strike the lamp (after setup is complete) and adjust it for optimum performance by turning the 3 adjustment screws one at a time until the brightest part of the beam is centered.

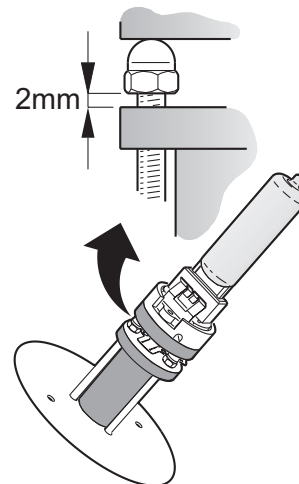
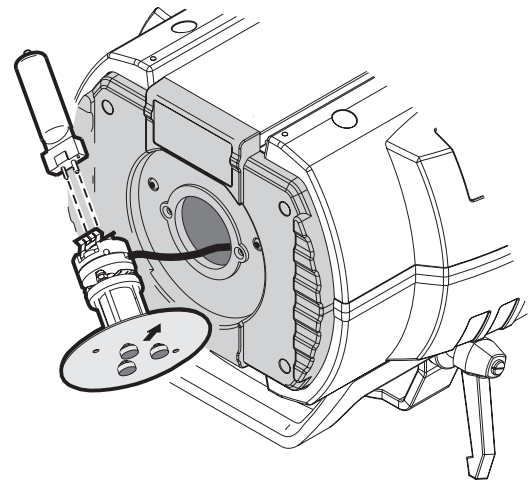
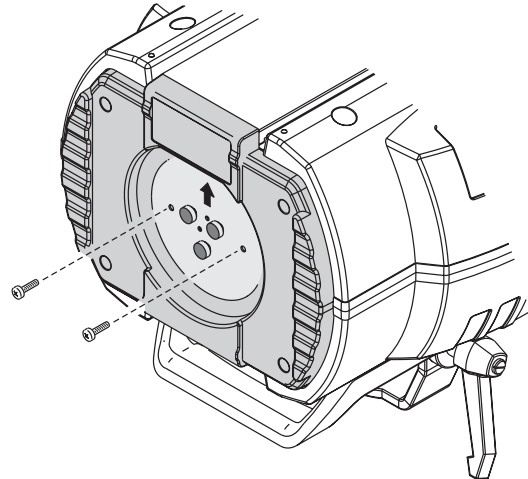

## Cleaning

### OPTICAL COMPONENTS

Use care when cleaning optical components. The surface on dichroic filters is achieved by means of special multi-layer coatings and even small scratches may be visible. Residues from cleaning fluids can bake onto components and ruin them.

- 1 Allow the components to cool completely.
- 2 Wash dirty lenses and filters with isopropyl alcohol. A generous amount of regular glass cleaner may also be used, but no residues may remain.
- 3 Rinse with distilled water. Mixing the water with a small amount of wetting agent such as Kodak Photoflo will help prevent streaking and spotting.
- 4 Dry with a clean, soft and lint-free cloth or blow dry with compressed air.

## FAN

To maintain adequate cooling it is important that the fan be cleaned regularly.

- 1 Remove the fan by pulling out the locking pins on each side.
- 2 Clean with a soft brush, vacuum, or compressed air.
- 3 Place the fan back in position and press in the locking pins to secure.

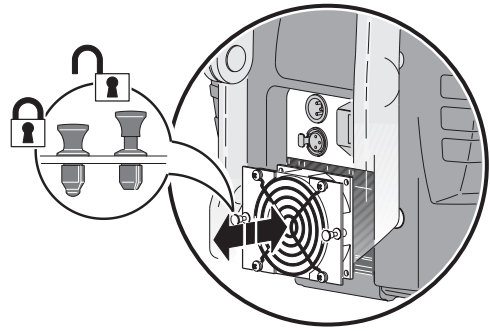

## Lubrication

Use only silicone lubricant, Martin P/N 37302003 (500 ml) or P/N 37302004 (200 ml, in applicator bottle). No other lubricant is approved for use. When applying lubricant, always remove excess and do not get oil on other parts.

Check the focus mechanism and apply a drop of lubricant to the spindle if movement is rough.

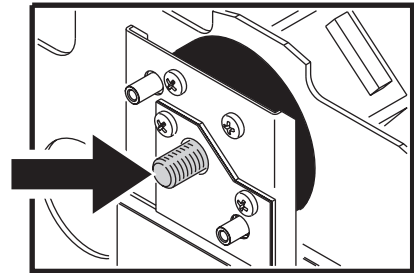

## Replacing fuses

### MAIN FUSE

The main fuse holder is built in to the mains input socket. *Never replace the fuse with one of a different rating!*

- 1 Unplug the mains cable from the input socket.
- 2 Pry open the fuse holder and remove the fuse.
- 3 Replace the fuse with one of the same type and rating. The fuse rating is listed on serial number label.
- 4 Close the fuse holder and replace the mains cable.

AC input & fuse holder

Data input

Data output

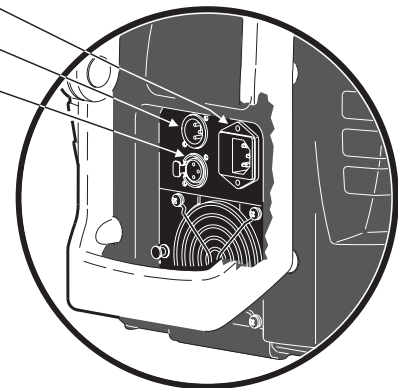

### POWER SUPPLY FUSES

There are two fuses for the low-voltage power supplies located on the printed circuit board. If one or more of the green LEDs on the PCB does not light, one of these fuses may be blown. If all three LEDs are lit, the low-voltage power supplies are functioning correctly.

Have the fixture serviced by a Martin service technician if the problem persists.

- 1 Disconnect the fixture from AC power.
- 2 Remove the front cover.
- 3 Remove the four screws that fasten the control panel assembly. Move the display assembly out of the way to access the PCB.
- 4 Carefully remove and check the two fuses located in the top-left corner of the PCB (see page 39). Replace as necessary with fuses of the same size and rating (see page 40).
- 5 Install the control panel and the front cover.

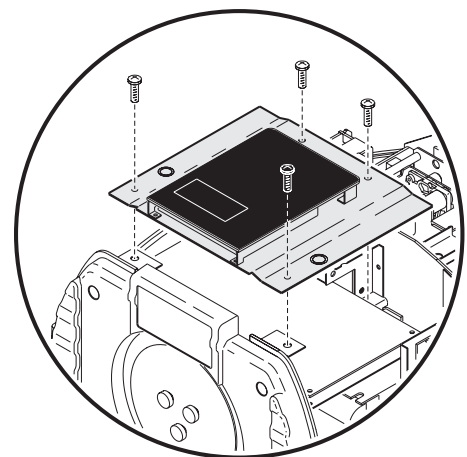

## Updating software

The latest CX-10 firmware is available from the support area of the Martin web site at <http://www.martin.com>. It can be installed using an MP-2, or via a PC serial data link using a hardware interface supported by the Software Uploader shareware (also available from the Martin web site). The following devices are currently supported (in Version 5.5):

- DABS 1 (presently available with the MUM software package)
- ShowDesigner PCI DMX Interface Card (2048 channel version)
- LightJockey PCI DMX Interface Card (512 and 2048 channel versions)
- LightJockey PCMCIA DMX Interface
- LightJockey 4064 ISA DMX Interface Card (DJ and Club versions)

Note: Intermediate control systems such as the Martin Lighting Director (MLD) and the Martin Matrix must be bypassed when updating fixture software via the DMX link. These systems do not relay the update code correctly because it is not a DMX-compliant signal.

### NORMAL UPDATE

To update fixture software, connect an upload device to the fixture just like a DMX controller and perform a DMX mode upload as described in the uploader's documentation. There is no need to isolate the CX-10s from other types of fixtures on the serial link.

When the upload is completed (and when booting up) the CX-10 performs a check-sum test of the flash memory and then resets. If the firmware is corrupted a check-sum error (CSEr) occurs. A few seconds later the fixture displays UPd and is ready for a new DMX-mode upload.

In the unlikely event that a software upload is interrupted, the fixture must be powered off for at least 10 seconds to force the check-sum test. You can repeat the DMX-mode upload as soon as UPd is displayed.

### BOOT SECTOR UPDATE

If the normal update procedure fails or the software update notes call for a boot-sector update, install new software as follows.

- 1 Disconnect the fixture from AC power.
- 2 Remove the front cover.
- 3 Remove the four screws that fasten the display assembly. Move the display assembly out of the way to access the PCB.
- 4 The boot sector jumper is located next to the plug for the control panel data cable. Move the jumper to the Init setting. Verify that the Flash Write jumper is in the Enable position. See the diagram on page 39.
- 5 Perform a boot-mode upload as described in the uploader manual.
- 6 Disconnect the fixture from AC power. Move the jumper back to the Lock setting.
- 7 Install the control panel and the front cover.

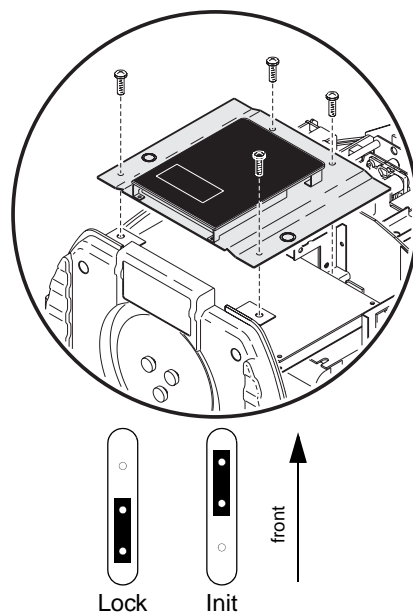

# DMX PROTOCOL

Channel	Value	Percent	Function
1  1- If DMX Reset is disabled in the menu, a reset command can only be executed if the CTC filter is selected, the prism is on (not rotating) and the open gobo is selected.  2 - If DMX Lamp Off is disabled in the menu, a lamp off command can only be executed if the CTC filter is selected, the prism is on (not rotating) and the open gobo is selected.	0 - 19	0 - 7	<b>Shutter, Strobe, Reset, Lamp On/Off</b> Shutter closed
	20 - 49	8 - 19	Shutter open
	50 - 72	20 - 28	Strobe, fast→slow
	73 - 79	29 - 31	Shutter open
	80 - 99	31 - 39	Opening pulse, fast→slow
	100 - 119	39 - 47	Closing pulse, fast→slow
	120 - 127	47 - 50	Shutter open
	128 - 147	50 - 58	Random strobe, fast
	148 - 167	58 - 65	Random strobe, medium
	168 - 187	66 - 73	Random strobe, slow
	188 - 190	74 - 75	Shutter open
	191 - 193	75 - 76	Random opening pulse, fast
	194 - 196	76 - 77	Random opening pulse, slow
	197 - 199	77 - 78	Random closing pulse, fast
	200 - 202	78 - 79	Random closing pulse, slow
	203 - 207	80 - 81	Shutter open
	208 - 217	82 - 85	Reset fixture, time > 5 seconds
	218 - 227	85 - 89	Shutter open
	228 - 237	89 - 93	Lamp on
	238 - 247	93 - 97	Shutter open
248 - 255	97 - 100	Lamp off: time > 5 seconds	
2	0 - 255	0 - 100	<b>Dimmer</b> Closed→open
3	0	0	<b>Color</b> <b>Continuous Scroll: full color positions:</b> White
	12	5	UV transmitter
	24	9	Yellow 603
	36	14	Blue 104
	48	19	Pink 312
	60	23	Green 206
	72	28	Blue 108
	84	33	Red 301
	96	37	Magenta 507
	108	42	Blue 101
	120	47	Orange 306
	132	42	Dark green
	144	56	Purple 502
	156 - 159	61 - 63	<b>Stepped Scroll</b> Purple 502
	160 - 163	63 - 64	Dark green
	164 - 167	64 - 65	Orange 306
	168 - 171	66 - 67	Blue 101
	172 - 175	67 - 68	Magenta 507
	176 - 179	69 - 70	Red 301
	180 - 183	70 - 72	Blue 108
	184 - 187	72 - 73	Green 206
	188 - 191	74 - 75	Pink 312
	192 - 195	75 - 76	Blue 104
	196 - 199	77 - 78	Yellow 603
	200 - 203	78 - 79	UV transmitter
	204 - 207	80 - 81	White
	208 - 210	82	<b>Random color</b> Fast
	211 - 213	83	Medium
	214 - 217	84	Slow
	218 - 236	85 - 92	<b>Continuous Rotation (use for animation discs)</b> CW (select speed on channel 6)
237 - 255	93 - 100	CCW (select speed on channel 6)	



Channel	Value	Percent	Function	
4			<b>Effects</b>	
			<b>Continuous Scroll: full effect positions:</b>	
	0	0	Open	
	12	5	Effect 1	
	24	9	Effect 2	
	36	14	Effect 3	
	48	19	Effect 4	
	60	23	Effect 5	
	72	28	Effect 6	
	84	33	Effect 7	
	96	37	Effect 8	
	108	42	Effect 9	
	120	47	Effect 10	
	132	42	Effect 11	
	144	56	Effect 12	
				<b>Stepped Scroll</b>
	156 - 159	61 - 63	Effect 12	
	160 - 163	63 - 64	Effect 11	
	164 - 167	64 - 65	Effect 10	
	168 - 171	66 - 67	Effect 9	
	172 - 175	67 - 68	Effect 8	
	176 - 179	69 - 70	Effect 7	
	180 - 183	70 - 72	Effect 6	
	184 - 187	72 - 73	Effect 5	
	188 - 191	74 - 75	Effect 4	
	192 - 195	75 - 76	Effect 3	
	196 - 199	77 - 78	Effect 2	
200 - 203	78 - 79	Effect 1		
204 - 207	80 - 81	Open		
			<b>Random effect</b>	
208- 210	82	Fast		
211 - 213	83	Medium		
214 - 217	84	Slow		
			<b>Continuous Rotation</b>	
218 - 236	85 - 92	CW (select speed on ch 5)		
237 - 255	93 - 100	CCW (select speed on ch 5)		
5	0 - 5	0 - 3	<b>Color Wheel Speed (or animation disc)</b> No Rotation	
	6 - 255	4 - 100		Slow→Fast
6	0 - 5	0 - 3	<b>Effect Wheel Speed</b> No Rotation	
	6 - 255	4 - 100		Slow→Fast
7	0 - 255	0 - 100	<b>Frost</b> Sharp edge→Frost	
8	0 - 255	0 - 100	<b>Focus</b> Infinity→2 meters	
9			<b>Reserved for macros.</b>	
10			<b>Effects Speed</b>	
			<b>Dimmer, focus, frost</b>	
	0 - 2	0 - 1	Tracking mode	
	3 - 245	1 - 96	Fast→slow	
	246 - 251	96 - 98	Tracking	
	252 - 255	99 - 100	Maximum speed	
				<b>Color (or animation disc)</b>
	0 - 2	0 - 1	Tracking mode	
	3 - 245	1 - 96	Speed, fast→slow	
	246 - 248	96 - 97	Tracking, SCUT OFF (menu override)	
	249 - 251	98 - 98	Tracking, SCUT ON (menu override)	
	252 - 255	99 - 100	Blackout while moving	
				<b>Effects</b>
	0 - 245	0 - 96	Normal (no blackout)	
	246 - 248	96 - 97	Normal, SCUT OFF (menu override)	
	249 - 251	98 - 98	Normal, SCUT ON (menu override)	
252 - 255	99 - 100	Blackout while moving		

# CONTROL MENU

Menu	Item	Options	Notes (Default settings in bold print)
Addr	-	1 - 512	DMX address
PERS	dISP	ON	Display remains on
		OFF	Display extinguishes 2 minutes after last key press
	dINT	AUTO	Automatic display dimming
		10 - 100	Set display intensity manually
	dLOF	ON	Enable DMX lamp off command
		OFF	Disable DMX lamp off command
	dRES	ON	Enable DMX reset command
		OFF	Disable DMX reset command
	ALON	ON	Lamp strikes automatically within 90 seconds of power on
		OFF	No automatic lamp strike
		dMX	Lamp strikes if DMX is present, douses 15 mins. after it's missing
	SCUT	ON	Effect wheels turn shortest distance
OFF		Effect wheels do not cross open position	
WHEL	COLR	Standard color wheel installed.	
	EFCT	Animation disc installed.	
dFSE	FACT	LOAD	Return all personality settings (not calibrations) to factory defaults
INFO	TIME / HRS	TOTL	Total hours of operation since fabricated
		RSET	Hours of operation since counter reset. To reset, display counter and press [up] for 5 seconds.
	TIME / L HR	TOTL	Total hours of operation with lamp on since fabricated
		RSET	Lamp hours since counter reset. To reset, display counter and press [up] for 5 seconds.
	TIME / L ST	TOTL	Total number of lamp strikes since fabricated
		RSET	Number of lamp strikes since counter reset. To reset, display counter and press [up] for 5 seconds.
VER	-	-	CPU firmware version
dMXL	-	RATE	DMX packets per second
		QUAL	Percentage of data received without errors
		STCO	Decimal value of the DMX start code.
		SHUT	DMX value (from 0 - 255) received in channel.
		DIM	DMX value (from 0 - 255) received in channel.
		COL	DMX value (from 0 - 255) received in channel.
		EFCT	DMX value (from 0 - 255) received in channel.
		FRST	DMX value (from 0 - 255) received in channel.
		FOC	DMX value (from 0 - 255) received in channel.
		EFSP	DMX value (from 0 - 255) received in channel.

Table 4: Control menu

Menu	Item	Options	Notes (Default settings in bold print)	
MAN	RST	-	Reset fixture	
	L ON	-	Lamp on	
	LoFF	-	Lamp off	
	SHUT	OPEN		Open shutter
		CLOS		Close shutter
		STRF		Fast strobe
		STRM		Medium strobe
		STRS		Slow strobe
	dIM	0-255	Dimmer	
	COL (color wheel or animation disc if installed)	C1		Color wheel in open position.
		C2-C13		Color wheel positions 2 > 13.
		CW F		Clockwise rotation - fast
		CCWF		Counter-clockwise rotation - fast
		CW M		Clockwise rotation - medium
		CCWM		Counter-clockwise rotation - medium
		CW S		Clockwise rotation - slow
		CCWS		Counter-clockwise rotation - slow
		RNdF		Random color - fast
		RNdM		Random color - medium
		RNdS		Random color - slow
	EFCT	Po 1		Open effect wheel position
		Po 2-Po 13		Effect wheel positions 2-13
		CW F		Clockwise rotation, fast
		CCWF		Counter-clockwise rotation, fast
		CW M		Clockwise rotation, medium
		CCWM		Counter-clockwise rotation, medium
		CW S		Clockwise rotation, slow
CCWS			Counter-clockwise rotation - slow	
RNdF			Random - fast	
RNdM			Random - medium	
RNdS			Random - slow	
FRST	0-255	Frost filter - open→closed		
FOC	0-255	Focus, Infinity→Near		
TSEQ	-	RUN	Run a general test of all effects	

Table 4: Control menu

Menu	Item	Options	Notes (Default settings in bold print)
UTIL (Press and hold Enter for a few seconds)	Adj	-	Not implemented.
	CAL	d1OF	Dimmer flag 1 offset
		d2OF	Dimmer flag 2 offset
		CoOF	Color wheel offset
		GoOF	Gobo wheel offset
		FoOF	Focus offset
		FrOf	Frost filter offset
		dFOF	Default offset. Sets all calibration offsets to 128.
	dFOF	SURE	Return all offsets to the default settings
	PCbT	LEd	PCB test for service use only.
UPLd	SURE	Manually set fixture to software update mode.	

**Table 4: Control menu**

# ERROR MESSAGES

Display readout	Appears if...	What to do
MERR (Memory error)	...the EEPROM memory cannot be read.	<ul style="list-style-type: none"> <li>• Contact service technician.</li> </ul>
CSER (Check-sum error)	...a software upload is unsuccessful.	<ul style="list-style-type: none"> <li>• Reload software, see page 31.</li> </ul>
****	... there is no communication between the control panel and motherboard. This appears briefly when switching on the fixture.	<ul style="list-style-type: none"> <li>• Check fuses.</li> <li>• Check cable between control panel and motherboard.</li> <li>• Reinstall software.</li> <li>• Contact service technician.</li> </ul>
COER (Color wheel time-out) GOER (Gobo wheel time out)	...the magnetic-indexing circuit malfunctions (e.g. sensor defective or magnet missing).	<ul style="list-style-type: none"> <li>• After the time-out, the effect in question stops in a random position.</li> <li>• Contact service technician.</li> </ul>

**Table 5: Error messages**

# TROUBLESHOOTING

Problem	Probable cause(s)	Remedy
One or more of the fixtures is completely dead.	No power to fixture.	<ul style="list-style-type: none"> <li>Check that power is switched on and cables are plugged in.</li> </ul>
	Primary fuse blown.	<ul style="list-style-type: none"> <li>Replace fuse.</li> </ul>
	Secondary fuse(s) blown (located on PCB inside base).	<ul style="list-style-type: none"> <li>Check fuses on PCB and replace.</li> </ul>
Fixtures reset correctly but all respond erratically or not at all to the controller.	The controller is not connected.	<ul style="list-style-type: none"> <li>Connect controller.</li> </ul>
	XLR pin-out of the controller does not match pin-out of the first fixture on the link (i.e. signal is reversed).	<ul style="list-style-type: none"> <li>Install a phase-reversing cable between the controller and the first fixture on the link.</li> </ul>
Fixtures reset correctly but some respond erratically or not at all to the controller.	Poor data quality	<ul style="list-style-type: none"> <li>Check data quality (page 11). If much under 100 percent, the problem may be a bad data link connection, poor quality or broken cabling, missing termination, or a defective fixture disturbing the link.</li> </ul>
	Bad data link connection	<ul style="list-style-type: none"> <li>Inspect connections and cables. Correct poor connections. Repair or replace damaged cables.</li> </ul>
	Data link not terminated with 120Ω termination plug.	<ul style="list-style-type: none"> <li>Insert termination plug in output jack of the last fixture on the link.</li> </ul>
	Incorrect addressing of the fixtures.	<ul style="list-style-type: none"> <li>Check address setting.</li> </ul>
	One of the fixtures is defective and disturbs data transmission on the link.	<ul style="list-style-type: none"> <li>Bypass one fixture at a time until normal operation is regained: unplug both connectors and connect them directly together.</li> <li>Have the defective fixture serviced by a qualified technician.</li> </ul>
	XLR pin-out on fixtures does not match (pins 2 and 3 reversed).	<ul style="list-style-type: none"> <li>Install a phase-reversing cable between the fixtures or swap pins 2 and 3 in the fixture that behaves erratically.</li> </ul>
Shutter closes suddenly.	The color wheel, or gobo wheel, has lost its index position and the fixture is resetting the effect.	<ul style="list-style-type: none"> <li>Contact Martin technician for service if the problem persists.</li> </ul>
No light and "LERR" error message displayed.	The power supply settings do not match local AC voltage and frequency.	<ul style="list-style-type: none"> <li>Disconnect fixture. Check settings (page 6) and correct if necessary.</li> </ul>
	Lamp missing or blown	<ul style="list-style-type: none"> <li>Disconnect fixture and replace lamp.</li> </ul>
Lamp cuts out intermittently.	Fixture is too hot.	<ul style="list-style-type: none"> <li>Allow fixture to cool.</li> <li>Clean fan.</li> <li>Make sure air vents at control panel and front lens are not blocked.</li> <li>Turn up the air conditioning.</li> </ul>
	The power supply settings do not match local AC voltage and frequency.	<ul style="list-style-type: none"> <li>Disconnect fixture. Check settings (page 6) and correct if necessary.</li> </ul>

**Table 6: Troubleshooting**

# PCB CONNECTIONS

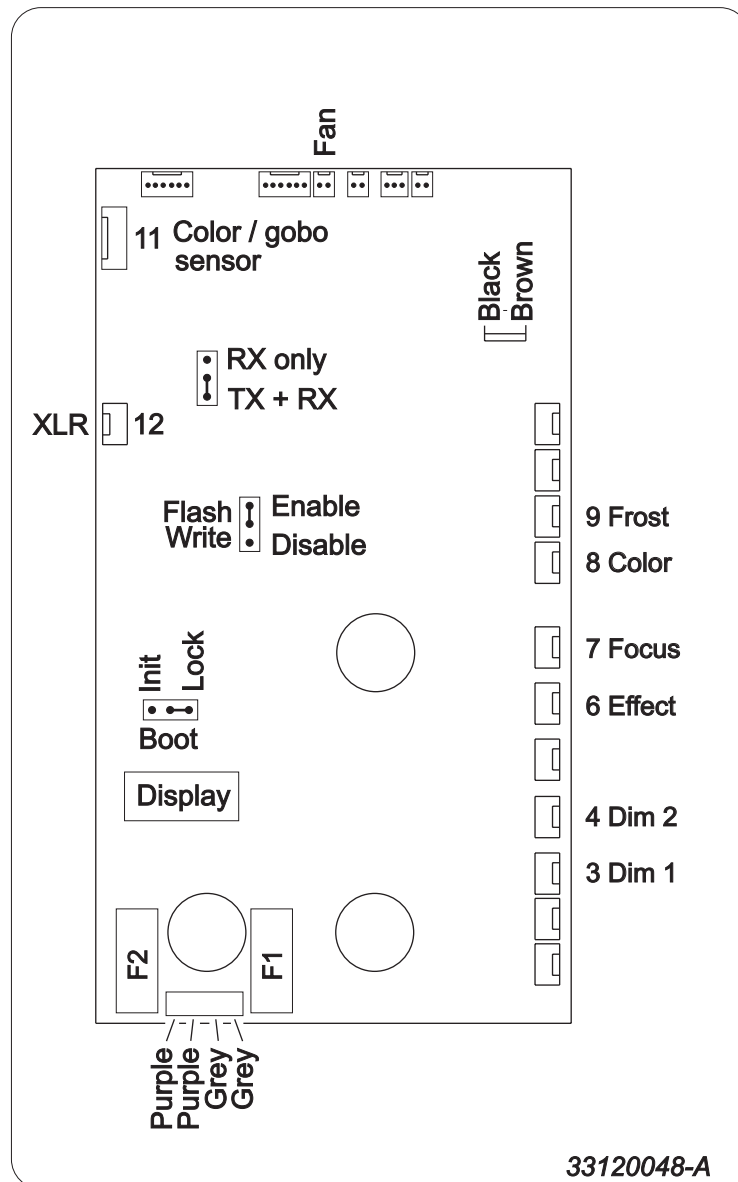

# SPECIFICATIONS - CX-10

## PHYSICAL

Length	412 mm (16.2 in)
Width	340 mm (13.4 in)
Height	326 mm (12.8 in)
Weight	19 kg (42 lbs)

## AC POWER

Operating range	100 - 250 V, 50/60 Hz
AC input	3-prong IEC male socket

## MAXIMUM POWER AND CURRENT

100 V, 50 Hz	350 W, 4.2 A
120 V, 50 Hz	340 W, 3.2 A
208 V, 50 Hz	350 W, 2.1 A
230 V, 50 Hz	360 W, 1.8 A
250 V, 50 Hz	350 W, 1.6 A
100 V, 60 Hz	340 W, 4.1 A
120 V, 60 Hz	340 W, 2.9 A
208 V, 60 Hz	340 W, 1.8 A
230 V, 60 Hz	350 W, 1.6 A
250 V, 60 Hz	350 W, 1.5 A

## THERMAL

Maximum ambient temperature ( $T_a$ )	40° C (104° F)
Maximum surface temperature	50° C (122° F)

## INSTALLATION

Orientation	any
Minimum distance to flammable materials	0.1 m (4 in)
Minimum distance to illuminated surfaces	0.3 m (12 in)

## FUSES

Main fuse	6.3 A / 250 V, time-delay
Fuse F1	6.3 A / 250 V, time-delay
Fuse F2	2.0 A / 250 V, time-delay

## LAMPS

Osram HSD 250	2000 hr, 6000K, 250 W, 68 lm/W
Philips MSD 250/2	3000 hr, 8500K, 250 W, 72 lm/W
Philips MSD 200	2000 hr, 5600K, 200 W, 67 lm/W

## PHOTOMETRICS

Beam angle	22°
Optional beam angles (orderable separately)	14° or 32°

## GOBOS

Outside diameter	22.5 mm + 0/- 0.3 mm (0.886 in. +0/- 0.012 in)
Maximum image diameter	17 mm (0.669 in)
Maximum thickness	1.8 mm (0.071 in)
Glass type	high temperature Borofloat or better
Glass coating	dichroic or enhanced aluminum
Metal	aluminum (steel okay for short use)



## CONTROL AND PROGRAMMING

Data input .....	locking 3-pin XLR male socket
Data output .....	locking 3-pin XLR female socket
Data pinout .....	pin 1 shield, pin 2 cold (-), pin 3 hot (+)
Receiver .....	Opto-isolated RS-485
Protocols .....	USITT DMX-512 (1990)
DMX Channels .....	10

## DESIGN STANDARDS

Canadian safety .....	CSA C22.2 NO 166
EU EMC .....	EN 50 081-1, EN 50 082-1
EU safety .....	EN 60598-1, EN 60598-2-17
US safety .....	ANSI/UL 1573

## ORDERING INFORMATION

CX-10 Extreme .....	P/N 90330000
---------------------	--------------

## ACCESSORIES

G-clamp .....	P/N 91602003
Half-coupler clamp .....	P/N 91602005
Narrow-angle lens kit (14° beam angle) .....	P/N 91610030
Wide-angle lens kit (32° beam angle) .....	P/N 91610029
Animation wheel adaptor kit .....	P/N 91611093
Linear breakup gobo animation wheel .....	P/N 62400223
Triangle break gobo animation wheel .....	P/N 62400225
Elliptical breakup gobo animation wheel .....	P/N 62400221
Flicker wheel gobo animation wheel .....	P/N 62400222
Coarse radial breakup gobo animation wheel .....	P/N 62400224
Coarse tangential breakup gobo animation wheel .....	P/N 62400226
Radial breakup gobo animation wheel .....	P/N 62400211
Cloud breakup animation wheel .....	P/N 62400213
Dot breakup animation wheel .....	P/N 62400214
Tangential breakup animation wheel .....	P/N 62400215
Spiral breakup animation wheel .....	P/N 62400216