

Yunzi+ 

VERY HIGH CONTRAST VIDEO-PROJECTOR

User Manual



BEST
Bi-level Efficiency Stereo Transmitter
3D PASSIVE

IR
RF **3D** ACTIVE
GLASSES



Dream Vision

WE MAKE THE WORLD DREAM

Changes

Dreamvision provides this manual 'as is' without warranty of any kind, either expressed or implied, including but not limited to the implied warranties or merchantability and fitness for a particular purpose. Dreamvision may make improvements and/or changes to the product(s) and/or the program(s) described in this publication at any time without notice.

This publication could contain technical inaccuracies or typographical errors. Changes are periodically made to the information in this publication; these changes are incorporated in new editions of this publication.

Copyright

All right reserved. No part of this document may be copied, reproduced or translated. It shall not otherwise be recorded, transmitted or stored in a retrieval system without the prior written consent of Dreamvision.

Guarantee

Dreamvision provides a guarantee relating to perfect manufacturing as part of the legally stipulated terms of guarantee. On receipt, the purchaser must immediately inspect all delivered goods for damage incurred during transport, as well as for material and manufacturing faults. Dreamvision must be informed immediately in writing of any complaints. If the purchaser or third party carries out modifications or repairs on goods delivered by Dreamvision, or if the goods are handle incorrectly, in particular if the systems are commissioned operated incorrectly or if, after the transfer of risks, the goods are subject to influences not agreed upon in the contract, all guarantee claims of the purchaser will be rendered invalid. Not included in the guarantee coverage are system failures which are attributed to programs or special electronic circuitry provided by the purchaser, e.g. interfaces. Normal wear as well as normal maintenance are not subject to the guarantee provided by Dreamvision either.

The environmental conditions as well as the servicing and maintenance regulations specified in this manual must be complied with by the customer.

Trademarks

Brand and product names mentioned in this manual may be trademarks, registered trademarks or copyrights of their respective holders. All brands and product names mentioned in this manual serve as comments or examples and are not to be understood as advertising for the products of their manufactures.

TABLE OF CONTENTS

1.0	SAFETY INSTRUCTIONS	5
1.1	Important Information	5
1.2	Regional Specific Information.....	5
1.3	Important Safeguards	5
2.0	INSTALLATION GUIDELINES	7
2.1	Introduction	7
2.2	THX-3D Display Certification	7
2.3	Environment of Use.....	8
2.4	Air-Flow and Space Requirements.....	8
2.5	Ceiling Mounting the Unit	8
2.6	Projection Distance.....	9
2.7	Setting the Lens and using Lens Memories.....	9
3.0	REMOTE CONTROL UNIT (RCU)	11
4.0	GETTING STARTED	12
4.1	General View	12
4.2	Connecting the Power Cord	12
4.3	Operating and Navigation Buttons	13
5.0	CONNECTIONS	13
5.1	Caution when connecting a Device to HDMI Input.....	13
5.2	Connecting a Video Source to the Projector.....	14
5.3	Connecting an Automation or Control device.....	14
6.0	MENU STRUCTURE	15
7.0	PICTURE ADJUST	18
7.1	Picture Modes and Color Profiles.....	18
7.2	Advanced Picture Mode	19
7.3	Advanced Color Profile	20
7.4	Color Temperature.....	20
7.5	Advanced Color Temperature.....	20
7.6	Gamma	20
7.7	Advanced Gamma	21
7.8	Multiple Pixel Control Level (MPC Level)	21
7.9	Clear Motion Drive (400Hz)	22
7.10	Contrast	22
7.11	Brightness.....	22
7.12	Color.....	22
7.13	Tint	22
8.0	INPUT SIGNAL	22
8.1	Input Level	22
8.2	Color Space	22
8.3	Control with HDMI (CEC*).....	22
8.4	Aspect Ratio	23
8.5	Progressive (only 480i, 576i, 1080i)	23
8.6	Mask	23
8.7	Picture Position.....	23
9.0	3D CONTENT AND 3D PROJECTION	23
9.1	General Information about 3D playback	23
9.2	Projector 3D Settings.....	24
10.0	INSTALLATION	24
10.1	Lens Control	24
10.2	Pixel Adjust	25
10.3	Keystone (Vertical).....	26
10.4	Pincushion	26

10.5	Anamorphic (works with 3D signal).....	26
10.6	High Altitude Mode.....	26
10.7	Environment Setting.....	26
11.0	DISPLAY SETUP	27
12.0	FUNCTION	27
12.1	Trigger.....	27
12.2	Off-Timer.....	27
12.3	ECO Mode.....	27
12.4	Network.....	27
12.5	Remote Code A or B.....	28
12.6	Lamp Reset.....	28
13.0	INFORMATION MENU	28
14.0	CINEMASCOPE SETUPS	28
14.1	Lens Zoom or 2.35 Theater System kit.....	28
14.2	Cinemascope setup with Lens Zoom.....	29
14.3	Installing a 2.35:1 screen with the 2.35 Theater System kit.....	29
15.0	MAINTENANCE	30
15.1	Cleaning and Replacing the Dust Filters.....	30
15.2	Dirt on the Lens.....	31
15.3	Replacing the Lamp.....	31
15.4	Troubleshooting.....	32
16.0	MISCELLANEOUS	33
16.1	RS-232C protocol.....	33
16.2	LAN protocol.....	37
16.3	Infra Red, long hex-pronto compatible RCU.....	38
16.4	Specifications.....	39

1.0 SAFETY INSTRUCTIONS

1.1 Important Information

Lead-free regulation

This product has a High Intensity Discharge (HID) lamp that contains a small amount of mercury. It also contains lead in some components. Disposal of these materials may be regulated in your community due to environmental considerations. For disposal or recycling information please contact your local authorities, or the Electronics Industries Alliance: <http://www.eiae.org>.

Information for Users on Disposal of Old Equipment



This symbol indicates that the electrical and electronic equipment should not be disposed as general household waste at its end of life. Instead, the product should be handed over to the applicable collection point for the recycling of electrical and electronic equipment for proper treatment, recovery and recycling in accordance with your national legislation.

By disposing of this product correctly, you will help to conserve natural resources and will help prevent potential negative effects on the environment and human health which could otherwise be caused by inappropriate waste handling of this product.

For more information about collection point and recycling of this product, please contact your local municipal office, your household waste disposal service or the shop where you purchased the product. Penalties may be applicable for incorrect disposal of this waste, in accordance with national legislation.

1.2 Regional Specific Information

CE mark and Directive 2011/65/EU - ROHS 2 (Europe only)

In accordance with Article 7 and the adoption into national law by 2nd January 2013, this product has been designed and manufactured in accordance with Article 4. The technical documentation and the written declaration of conformity that assesses the product conformity can be provided to the competent National Authority upon an email request to: rohs2@dreamvision.net

Other Countries outside the European Union:

If you wish to dispose of this product, please do so in accordance with applicable national legislation or other rules in your country for the treatment of old electrical and electronic equipment.

FCC Information (USA only)

Changes or modification not approved by Dreamvision could void the user's authority to operate the equipment. Note: This equipment has been tested and found to comply with the limits for Class B digital devices, pursuant to Part 15 of the FCC Rules. These limits are designed to provide reasonable protection against harmful interference in a residential installation. This equipment generates, uses, and can radiate radio frequency energy and, if not installed and used in accordance with the instructions, may cause harmful interference to radio communications. However, there is no guarantee that interference will not occur in a particular installation.

About the installation place

Do not install the projector in a place that cannot support its weight securely. If the installation place is not sturdy enough, the projector could fall or overturn, possibly causing personal injury.



To reduce the risk of electric shock, do not remove cover. Refer servicing to qualified service personnel. This projector is equipped with a 3-blade grounding type plug to satisfy FCC rule. If you are unable to insert the plug into the outlet, contact your electrician.



To prevent fire or shock hazards, do not expose this appliance to rain or moisture. This apparatus must be earthed.

1.3 Important Safeguards

Electrical energy can perform many useful functions. This unit has been engineered and manufactured to assure your personal safety. **IMPROPER USE CAN RESULT IN POTENTIAL ELECTRICAL SHOCK OR FIRE**

SAFETY INSTRUCTIONS

HAZARD. In order not to defeat the safeguards incorporated into this product, observe the following basic rules for its installation, use and service.



The power input is auto-ranging from 100 to 240 VAC.

Please read these Important Safeguards carefully before use.

- All the safety and operating instructions should be read before the product is operated.
 - All warnings on the product and in the operating instructions should be adhered to.
 - All operating instructions should be followed.
 - Place the projector near a wall outlet where the plug can be easily unplugged.
 - Unplug this product from the wall outlet before cleaning. Do not use liquid cleaners or aerosol cleaners. Use a damp cloth for cleaning.
 - Do not use attachments not recommended by the product manufacturer as they may be hazardous.
 - Do not use this product near water. Do not use immediately after moving from a low temperature to high temperature, as this causes condensation, which may result in fire, electric shock, or other hazards.
 - Do not place this product on an unstable cart, stand, or table. The product may fall, causing serious injury to a child or adult, and serious damage to the product. The product should be mounted according to the manufacturer's instructions, and should use a mount recommended by the manufacturer.
 - When the product is used on a cart, care should be taken to avoid quick stops, excessive force, and uneven surfaces which may cause the product and cart to overturn, damaging equipment or causing possible injury to the operator.
-



Slots and openings are provided for ventilation must not be blocked or covered. Do not place this unit on a bed, sofa, rug or other similar surface.

- This product should be operated only with the type of power source indicated on the label. If you are not sure of the type of power supply to your home, consult your product dealer or local power company.
- This product is equipped with a three-wire plug. This plug will fit only into a grounded power outlet. If you are unable to insert the plug into the outlet, contact your electrician to install the proper outlet. Do not defeat the safety purpose of the grounded plug.
- Power-supply cords should be routed so that they are not likely to be walked on or pinched by items placed upon or against them. Pay particular attention to cords at doors, plugs, receptacles, and the point where they exit from the product.
- For added protection of this product during a lightning storm, or when it is left unattended and unused for long periods of time, unplug it from the wall outlet and disconnect the cable system. This will prevent damage to the product due to lightning and power line surges.
- Do not overload wall outlets, extension cords, or convenience receptacles on other equipment as this can result in a risk of fire or electric shock.
- Never push objects of any kind into this product through openings as they may touch dangerous voltage points or short out parts that could result in a fire or electric shock. Never spill liquid of any kind on the product.
- Do not attempt to service this product yourself as opening or removing covers may expose you to dangerous voltages and other hazards. Refer all service to qualified service personnel.
- Unplug this product from the wall outlet and refer service to qualified service personnel under the following conditions:
 - a) When the power supply cord or plug is damaged.
 - b) If liquid has been spilled, or objects have fallen on the product.
 - c) If the product has been exposed to rain or water.
 - d) If the product does not operate normally by following the operating instructions. Adjust only those controls that are covered by the Operation Manual, as an improper adjustment of controls may result in damage and will often require extensive work by a qualified technician to restore the product to normal operation.
 - e) If the product has been dropped or damaged in any way.
 - f) When the product exhibits a distinct change in performance - this indicates a need for service.
- When replacement parts are required, be sure the service technician has used replacement parts specified by the manufacturer or with same characteristics as the original part. Unauthorized substitutions may result in fire, electric shock, or other hazards.
- Upon completion of any service or repairs to this product, ask the service technician to perform safety checks to determine that the product is in proper operating condition.
- The product should be placed more than one foot away from heat sources such as radiators, heat registers,

stoves, and other products (including amplifiers) that produce heat.

- When connecting other products such as VCR's, and personal computers, you should turn off the power of this product for protection against electric shock.
- Do not place combustible behind the cooling fan. For example, cloth, paper, matches, aerosol cans or gas lighters that present special hazards when over heated.



Do not look into the inside of this unit through vents (ventilation holes). Do not look at the illumination lamp directly by opening the cabinet while the illumination lamp is turned on. The illumination lamp also contains ultraviolet rays and the light is so powerful that your eyesight can be impaired.

- Do not drop, hit, or damage the light-source lamp (lamp unit) in any way. It may cause the light-source lamp to break and lead to injuries. Do not use a damaged light source lamp. If the light-source lamp is broken, ask your dealer to repair it. Fragments from a broken light-source lamp may cause injuries.
- The light-source lamp used in this projector is a high pressure mercury lamp. Be careful when disposing of the light source lamp. If anything is unclear, please consult your dealer.
- Do not ceiling-mount the projector to a place which tends to vibrate; otherwise, the attaching fixture of the projector could be broken by the vibration, possibly causing it to fall or overturn, which could lead to personal injury.
- The power supply voltage rating of this product is AC120 V, AC100 V – AC240 V, the power cord attached conforms to the following power supply voltage. Use only the power cord designated by our dealer to ensure Safety and EMC.
- When it is used by other power supply voltage, power cable must be changed. Ensure that the power cable used for the projector is the correct type for the AC outlet in your country. Consult your product dealer.
- Caution: Do not allow any unqualified person to install the unit. Be sure to ask your dealer to install the unit (e.g. attaching it to the ceiling) since special technical knowledge and skills are required for installation. If installation is performed by an unqualified person, it may cause personal injury or electrical shock.

2.0 INSTALLATION GUIDELINES

2.1 Introduction

This product is powered by a three-chip LCoS light engine and uses three Full-HD panels to project a picture of up to 3840 x 2160 pixels (Ultra HD, 4K). It supports both Standard and High Definition video formats up to 4K inputs (Ultra HD 4K: 3840x2160 pixels) on one of the two available HDMI inputs.

Supported 2D signals

480p, 576p, 720p@50/60, 1080i/p@50/60, 1080p/24, 4Kp24/25/30: 3840x2160@24/25/30Hz, 4Kp50/60: 3840x2160@50/60Hz (YCbCr 4:2:0 only).

2.2 THX-3D Display Certification



D I S P L A Y

The THX-3D Display certification aim to reproduce faithfully images at home according to the intentions of the film director during playback of 2D and 3D images, and they are the proof of high definition and high quality, indicating that Yunzi+2&3 have cleared more than 400 rigorous image quality tests including accuracy of color reproduction, cross-talk, viewing angle and video processing performance. The THX certification features by using THX picture mode:

- Correct Gamma and Color Temperature
- No Overscan or Scaling
- Correct High Definition color Gamut

The Best in Class Parameters also include ANSI and Sequential contrast, luminance and color Uniformity, color tracking with gray scale, optimum brightness, deinterlacing performance, jaggie and countouring.

Supported 3D signals

This unit is compatible with 3D playback. The source can be connected using one of the two available HDMI inputs. This unit is compatible with the following 3D formats:

- 1080p @ 23.98/24Hz - Frame Packing, Top & Bottom and Side-by-Side
- 720p @ 50 or 59.94/60Hz - Frame Packing, Top & Bottom and Side-by-Side
- 1080i/p @ 50/60Hz - Side-by-Side

2.3 Environment of Use

This unit makes use of a light source lamp that reaches a high temperature during projection. Do not allow projection under the following conditions:

- Projection with the unit laid on sides.
- Projection at a location that blocks the air inlets or exhaust vents.
- Projection at a place exposed to air blasts from an air conditioner.

Allowed Inclination during operation

Due to the lamp position and operating angle, this unit cannot operate with more than 5° angle horizontally and 15° angle vertically. This unit cannot be operated on the side.

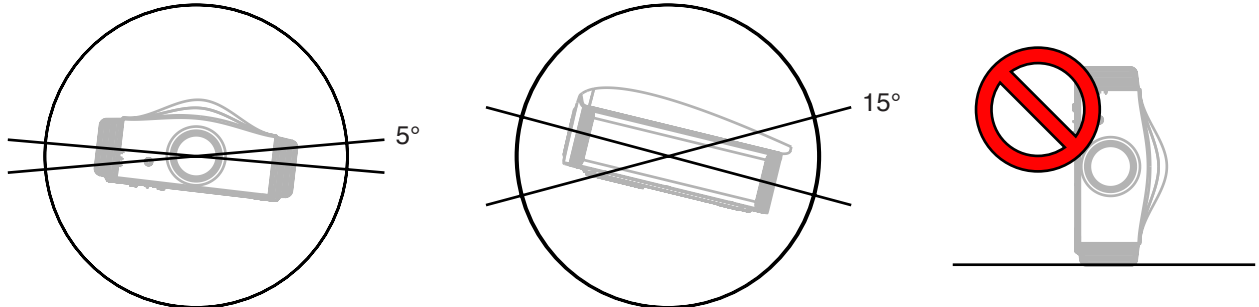

2.4 Air-Flow and Space Requirements

This unit can be installed in table, ceiling, rear table or rear ceiling position. Make sure that the unit is installed within the space requirements described below (A: air inlets, B: air outlets). This unit needs at least 20cm of non-obstructed space on each side to allow a sufficient air flow.

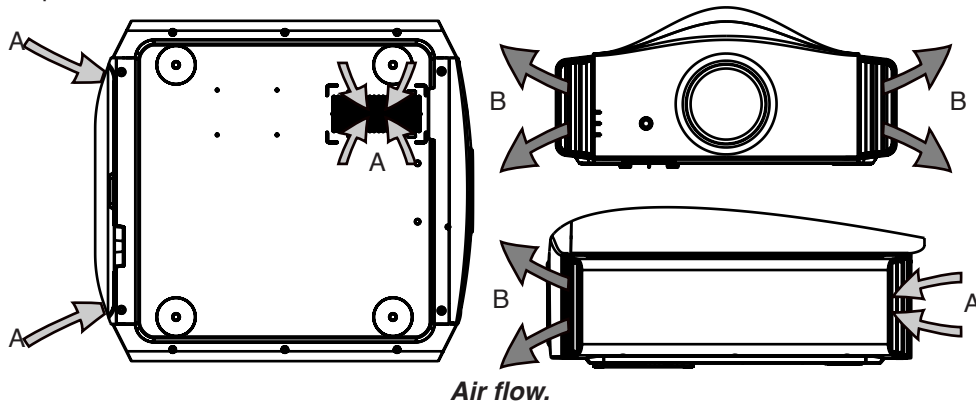

2.5 Ceiling Mounting the Unit

When mounting of this unit is required, make use of the 4 screw holes (M5x20 screws) at the bottom of this unit indicated by the letter A. Allow sufficient space around the air inlets to avoid blocking them.

Precautions for Ceiling-mount

- To ceiling-mount this unit, special expertise and techniques are necessary. Be sure to ask your dealer or specialist to perform mounting.
- Do not mount at places that may be subjected to vibration and shock.
- Depth of the screw holes (A) is 23 mm. Use at least 13mm long screws but not longer than 23mm as you may damage inside the projector.
- Install at a safe place in case this unit or a part of it may drop. If the light-source lamp is broken, small pieces of glass from the mesh of the filter may appear outside the unit.
- Regardless whether the unit is still under guarantee, Dreamvision

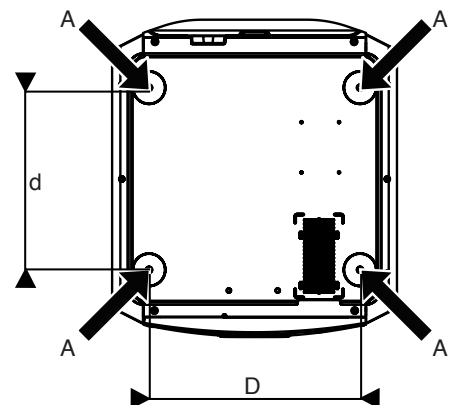

is not liable for any product damage caused by mounting the unit with third party ceiling mount or when the environment is not suitable for ceiling-mount.

Dimensions

- Distances between left and right holes is $D = 337$ mm.
- Distances between front and back holes is $d = 290$ mm.

2.6 Projection Distance

Projection Screen Diagonal Size (Aspect Ratio 16:9)	Projection Screen Base Size (Aspect Ratio 16:9)	Projection Screen Height (Aspect Ratio 16:9)	Yunzi+ Projection Distance
50" (127 cm)	43.6" (111 cm)	24.5" (623 cm)	151 cm - 305 cm
60" (152 cm)	52.3" (133 cm)	29.4" (747 cm)	178 cm - 366 cm
70" (178 cm)	61.0" (155 cm)	34.3" (872 cm)	209 cm - 428 cm
83" (211 cm)	72.3" (184 cm)	40.7" (103 cm)	251 cm - 507 cm
100" (254 cm)	87.2" (221 cm)	49.0" (125 cm)	301 cm - 613 cm
110" (279 cm)	95.9" (244 cm)	53.9" (137 cm)	331 cm - 675 cm
138" (350 cm)	120.3" (306 cm)	67.7" (172 cm)	418 cm - 843 cm
150" (350 cm)	130.7" (332 cm)	73.5" (187 cm)	453 cm - 860 cm
180" (457 cm)	156.9" (306 cm)	88.2" (224 cm)	545 cm - 1107 cm
200" (508 cm)	174.3" (443 cm)	98.1" (249 cm)	606 cm - 1230 cm

- The projection screen sizes and projecting distances in the table above are provided only as a guide. Please use them as reference during installation.
- The distances are calculated for a projection image of 16:9 aspect ratio

2.7 Setting the Lens and using Lens Memories

Adjust the picture position

The optimum image can be obtained when the centre of this projector's lens and the screen are placed perpendicular to each other. Take note of the projection angle when placing them. You can also use up to $\pm 15^\circ$ up and down position and configure trapezoidal correction.

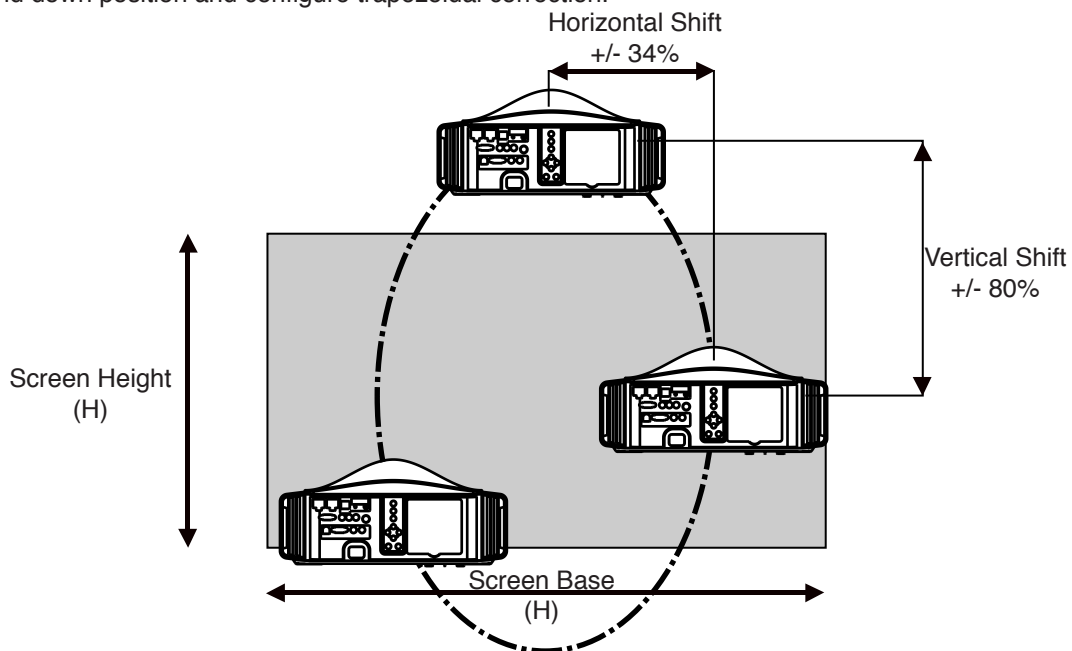

This unit comes with a vertical and horizontal shift to suit most installations. Make sure that your installation does not exceed 80% vertical offset and 34% horizontal offset to avoid trapezoidal correction.

This unit comes with a optical shift that features vertical and horizontal adjustment of the projection screen

position

Adjust the picture to your screen.

- The Vertical Shift level is between -80% and 80% of the Screen Height (0.80 x H).
- The Horizontal Shift level is between -34% and 34% of the Screen Base (0.34 x B).
- If the projector is not installed perpendicularly to the screen, use keystone correction to fulfill your screen. Note that using keystone correction, may be disabled by 3D projection. If you want the best possible 3D pictures, It is not recommended to use trapezoidal correction.
- If you plan to use the vertical and horizontal shifts without keystone correction, make sure to not exceed the values contained in the tab below:

Left / Right shift	0%	5%	10%	15%	20%	25%	30%	34%
max. up / down shift	80%	74%	66%	57%	47%	34%	18%	0%

• Adjust the picture position

The Yunzi+ projector has motorized vertical and horizontal shifts. Browse into the Menu to the [Lens Control] setting into the Installation menu, select the shift adjustment. Or use the direct access button on the Remote Control Unit [Lens Control] to make the lens adjustment. You can use self-generated test pattern of the projector or an external pattern, from a calibration DVD by example, by setting the Adjust pattern option to Off.

• Adjust the picture Zoom

Into the [Lens Control] menu, press the [Ok] button to access the Zoom adjustment. Use the up and down buttons to adjust the picture size until the screen is completely filled.

• Adjust the Picture Focus

From the [Lens Control] menu, press the [Ok] button to access the Focus adjustment. Use the up and down buttons to adjust the picture focus

Using Lens Memories

You can save the current picture position, zoom and focus in up to 5 different Lens Memories (10 for Yunzi+2&3). Each memory stores the current position, zoom, focus of the lens and you can also set a custom name of 10 characters or less.

• Saving current lens setup

Fist step is to set the lens to fill the desired screen. Then go into the Menu > Installation > Lens Control, Select Lens Memory Save and choose a free slot available. You can call back anytime later this current lens setup using the direct access button [Lens Mem]ory on the RCU.

• Limitations of use

Each memory can store a different picture size and position, but there are limitations on the possible pictures sizes and positions because of the projector being at a fixed location. In order to calculate the best position of the projector toward the screen, the installer has to make sure that among the different desired pictures, the smaller one with the smaller zoom, is within the offset limits (horizontal and vertical shifts) of the projector. Once the position of the projector is determined by the smallest possible picture, double check that the larger one does not exceed the zoom capacity.

3.0 REMOTE CONTROL UNIT (RCU)

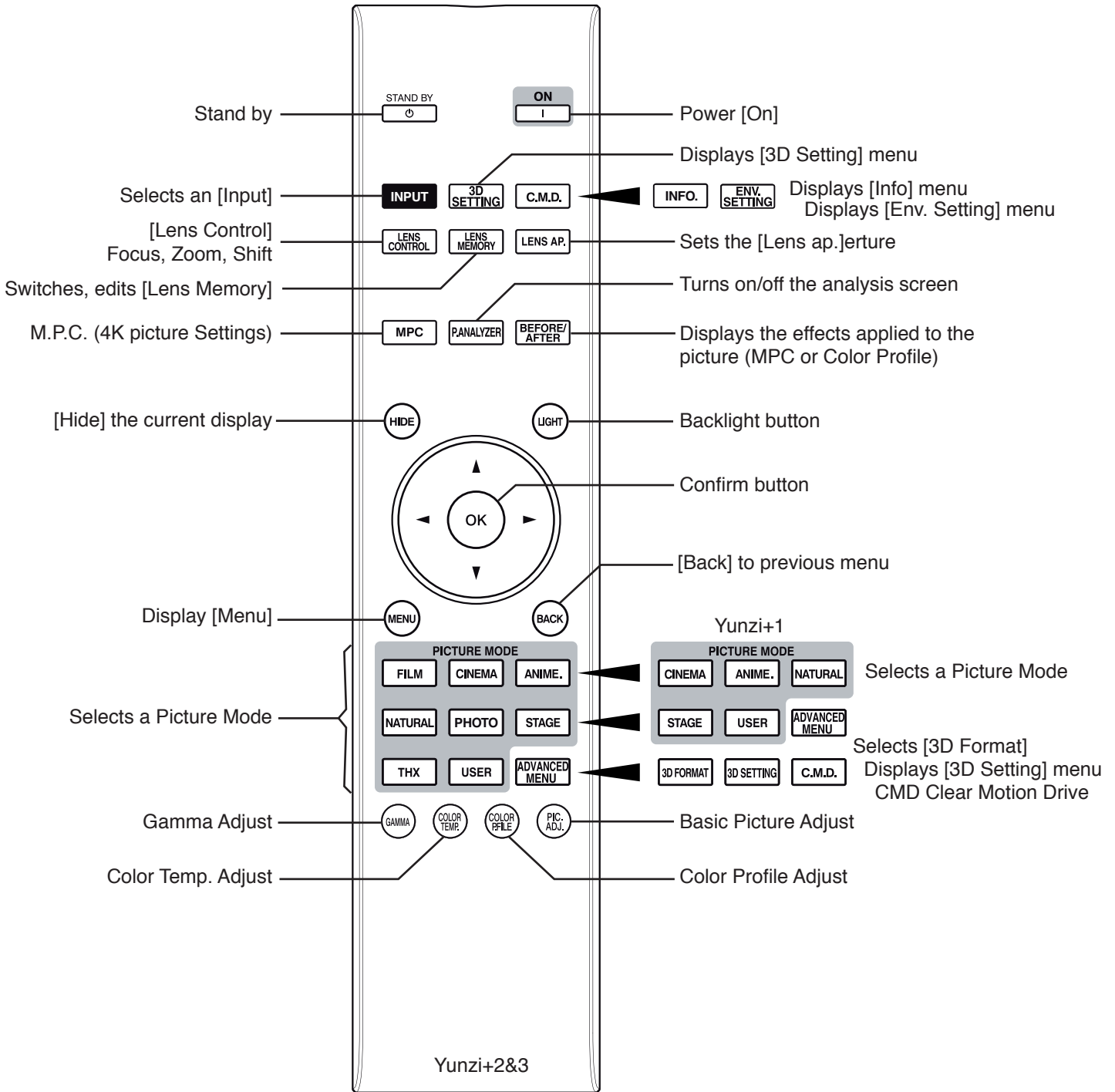

The remote control unit can be used by having the signal reflected off a screen, as the effect of signals reflected differs with the type of screen used, operable distance may decrease.



If the remote control has to be brought closer to the projector to operate, it means that the batteries are wearing out. When this happens, replace the batteries. Always insert the batteries according to the + and - marks.

4.0 GETTING STARTED

4.1 General View

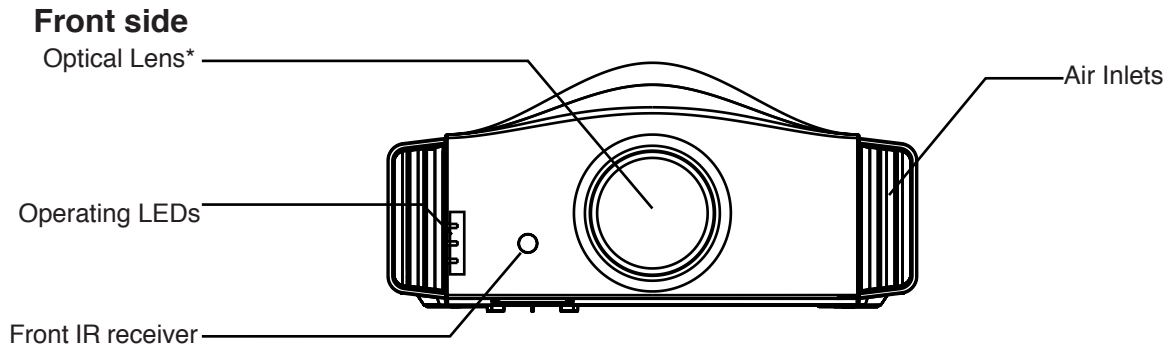

(*) Optical Lens: On the Yunzi+2&3 models, the optical lens is protected by a motorized lens cover.

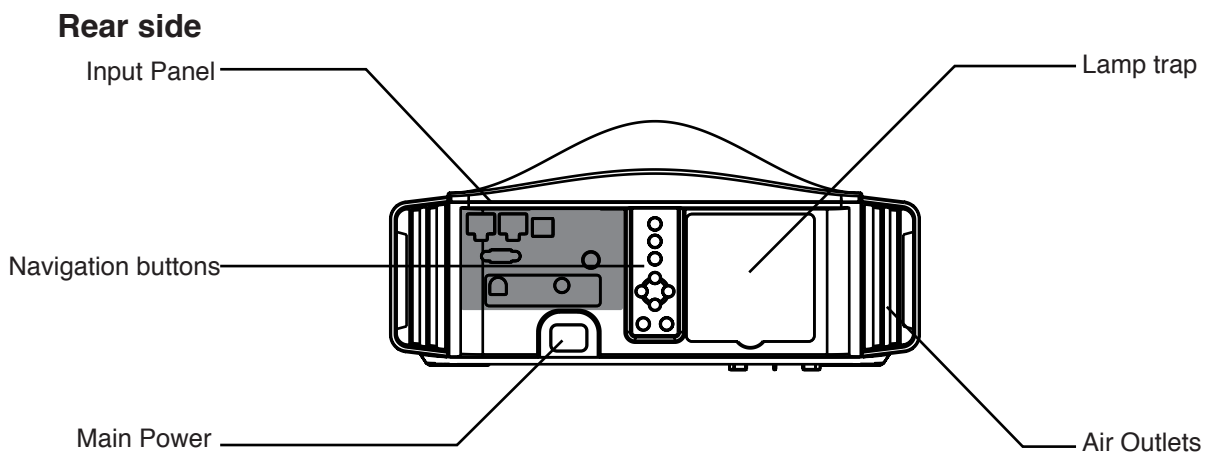

- Input Panel: connect your video source to the correct input.
- Main Power: connect the power cord as shown below.
- Lamp trap: see “15.3 Replacing the Lamp”, page 31 for more details about lamp replacement.

4.2 Connecting the Power Cord

- Before plugging in the Power Cord, ensure that all devices have been connected to their respective inputs of this unit.
- Connect the power cord to the power input terminal of the projector.

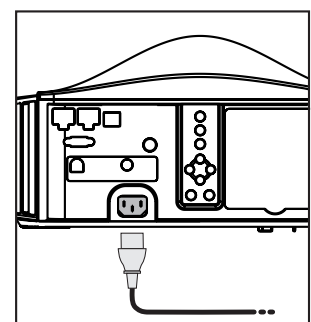

When in Cool Down mode, do not pull out the plug from the outlet. Also, do not block the air inlets or exhaust vents by standing the projector on its end or laying it on its side.

4.3 Operating and Navigation Buttons

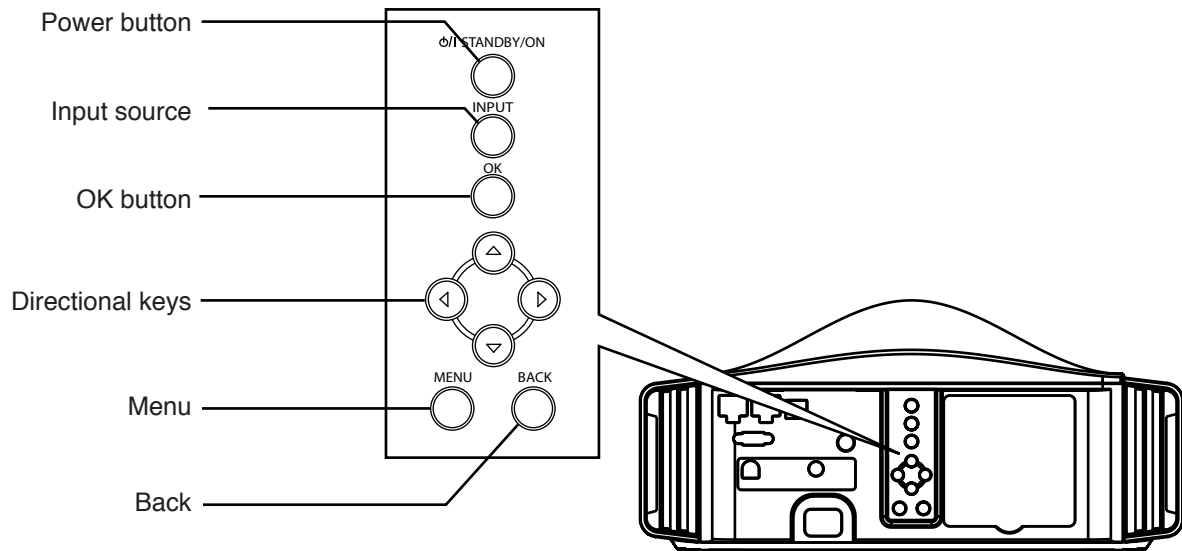



Button	Description
Power	To turn ON or OFF the projector.
Input source	To switch input source between HDMI 1 and HDMI 2.
OK button	To select or to confirm action.
Directional keys	To navigate into On Screen Display (OSD) Menu.
Menu	To display On Screen Display (OSD) Menu.
Back	To return to previous menu or cancel action.

5.0 CONNECTIONS

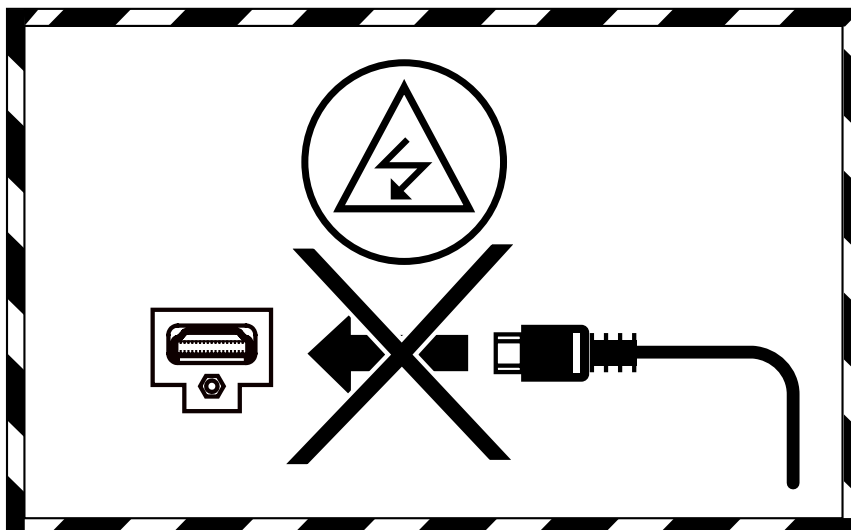
5.1 Caution when connecting a Device to HDMI Input



 Prior to connecting any device to this unit, switch the projector in standby mode. Never connect a HDMI source to this unit when the projector is in operate mode. The HDMI termination is a self-powered connection and can cause electric discharges.

 If a HDMI input is locked to a fixed resolution or cannot be synchronised correctly, switch OFF this unit, UNPLUG the main power cord for a few minutes before powering it up again.

5.2 Connecting a Video Source to the Projector

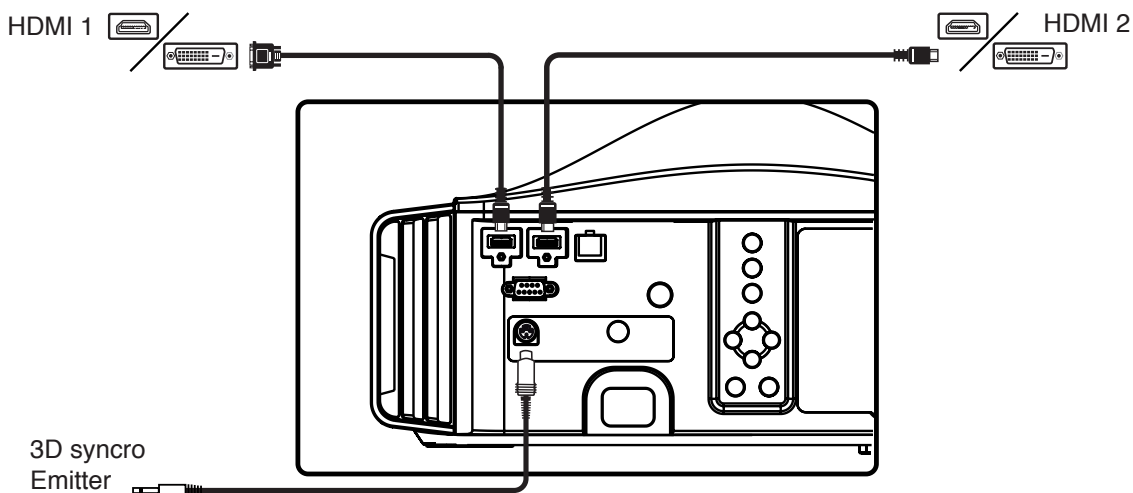

Audio/Video Connection	Device to connect
HDMI 1, HDMI 2 (DVI compatible)	HDMI or DVI-D sources: Blu-ray Disc player, DVD-player equipped with HDMI output, Game Console, Computer with DVI-D output.
3D Synchro output	3D synchro emitter to control active shutter glasses. 3-PIN mini-DIN interface, 12V.



This unit supports up to 4Kp60 inputs, make sure to use high quality HDMI cables rated for 4K HDMI 1.4 or HDMI 2.0 standards.

5.3 Connecting an Automation or Control device

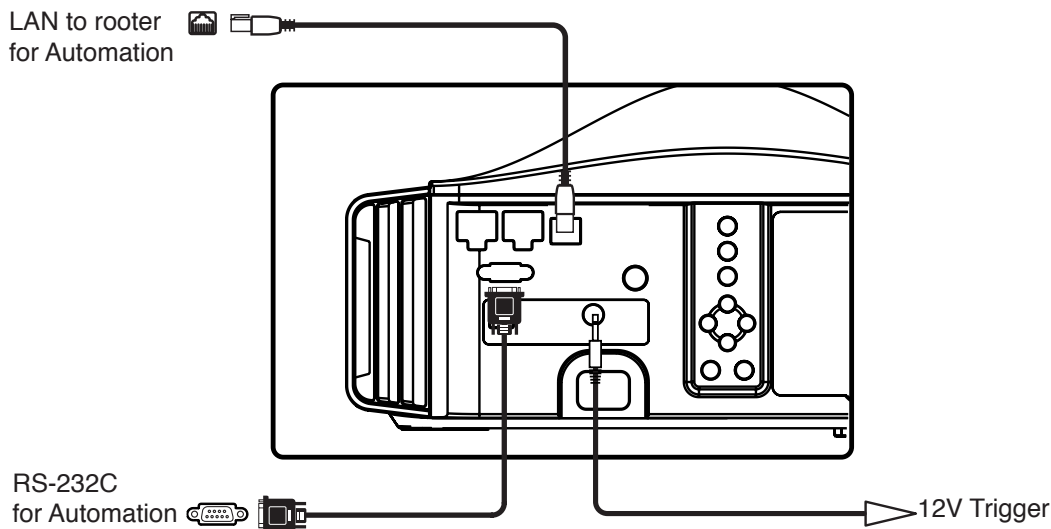

Connection	Device to connect
RS-232 C	Automation Device, Control Device or Computer with RS-232 capability.
12V Trigger	DC power supply output 12V@140-300mA to control either a screen or an anamorphic lens motorization.
LAN	Automation Device, Control Device or Computer with RJ-45.



CONNECTING AN AUTOMATION/CONTROL DEVICE

This unit can control or be controlled by using several input/output terminals. Each terminal is ruled by specific protocols. Please refer to Appendix for more information.

6.0 MENU STRUCTURE

MAIN MENU	SUBMENU	AVAILABLE OPTIONS
Picture Adjust	Picture Mode (5+4 User)	(Digital Cinema) Cinema (SF movies or animes) Animation (Video programs) Natural (Concerts, theatrical rep.) Stage (available only for 4K50/60p input) 4k50/60p User1 User2 User3 User4
	Picture Modes (Yunzi+2&3) (total of 12 + 4 User)	(Movies) Film (Photos) Photos THX THX bright(*) THX dark(*) ISF Day(*) ISF Night(*)
	(*) for expert users, require individual calibration	
Advanced Picture Mode (press OK)	Clear Black	Off, Low, High
	Lamp Power	Low, High
	Lens Aperture	
	(standard)	Auto 1
	(more contrasted)	Auto 2
	Manual	-15 +0
	User Name Edit (if f User 1 - 4 selected)	
	edit name	10 char. max
Color Profiles the list varies upon current Picture Mode	(HDTV)	Standard
	(Digital Cinema standard)	Cinema
	(Animations)	Animation
	(TV, sports)	Natural
	(Live concerts)	Stage
	(3D movies)	3D Cinema
	(3D animations)	3D Animation
	(3D broadcasts, 3D TV)	3D Video
	(Live 3D concerts)	3D Stage
	(*) require individual adjustment and/or calibration	(available only with User P.Mode) x.v.Color Custom 1 - 5(*)
Color Profiles (Yunzi+2&3) the list varies upon current Picture Mode	(Eastman Kodak movies)	Film1
	(Fujifilm movies)	Film2
	(Technicolor movies)	Film3
	(HDTV)	Standard
	(Movies)	Cinema1
	(Digital Cinema standard)	Cinema2
	(Animations)	Anime1
	(Richer colors than Anime1)	Anime2
	(TV, sports)	Video
	(Computer inputs)	AdobeRGB
	(Live concerts)	Stage
	(THX)	THX
	(3D films)	3D Film
	(3D movies)	3D Cinema
	(3D TV programs, sports)	3D Video
	(3D animations)	3D Animation
	(3D photo materials)	3D Photo
	(3D concerts)	3D Stage
	(3D THX)	3D THX
	(*) require individual adjustment and/or calibration	(available only with User P.Mode) x.v.Color Custom 1 - 5(*)

MENU STRUCTURE

Advanced Color Profile	Color Management:	Off / On
	Color selection	
	Axis Position	-30 +30
	Hue	-30 +30
	Saturation	-30 +30
	Brightness	-30 +30
	Reset	Confirm
Color Temp.	Xenon Modes (Yunzi+2&3)	
	(Film projector)	Xenon1
	(DCI projector)	Xenon2
	(Cooler than DCI)	Xenon3
	Preset value:	
	5500K - 6000K - 6500K - 7000K	
	7500K - 8000K - 8500K - 9000K	
	9500K - High Bright - Custom 1-3	
Advanced Color Temp	If Custom 1-3, choose Correction Value	
	Gain and Offset	settings
	Reset	Confirm
Gamma	If Color Profile is Film1 to 3	
	(standard)	Film1
	(more contrasted)	Film2
		Custom1 to 3
	If Color Profile is not Film	
	(fixed for x.v.Color)	Normal
		Brightness Priority
		Contrast Priority
		Gradation Priority
		Custom1 to 3
	If Color Profile is THX	THX
Advanced Gamma	If Custom1-3, choose Gamma Corr. Value	
		Normal
		Brightness Priority
		Contrast Priority
		Gradation Priority
		1.8 to 2.6
		Import
	Color Selection	White / Red / Green / Blue
	Picture Tone	-16 +16
	Dark Level	-7 +7
	Bright Level	-7 +7
	Reset	Confirm
MPC Level	4K e-shift (4K)	On, Off
	Resolution	Auto, 4K, 1080p, 1080i / 720p, 480p
	Enhance	0 - 100
	Dynamic Contrast	0 - 100
	Smoothing	0 - 100
	Noise Reduction	0 - 10
	Reset	Confirm
Clear Motion Drive		Off, Low, High, Inverse Telecine
(**) cannot be adjusted for x.v.Color input	Brightness (**)	-50 +50
	Contrast (**)	-50 +50
	Color (**)	-50 +50
	Tint (reddish to greenish) (**)	-50 +50
	Reset Profile settings	Confirm
Input Signal	Input level	Auto (16 - 235) Standard (0 - 255) Enhanced (16 - 255) Super White

Input Signal	Color Space (fixed to YCbCr(4:2:0) with 4Kp50/60 input)	Auto YCbCr(4:4:4) YCbCr(4:2:2) RGB	
	Control with HDMI (CEC)	On, Off	
	Aspect (Video only) if 3D, only 16:9 is available	4:3 16:9 Zoom	
	Aspect (PC only)	Auto 1:1 Full	
	Progressive (480i, 576i, 1080i)	Auto, Off	
	Mask	5%, 2.5%, Off Custom Top 0 - 28 Bottom 0 - 28 Left 0 - 48 Right 0 - 48	
	3D Setting	3D format Auto / Side-by-Side / Top & Bottom / 2D 2D to 3D Conversion On, Off Parallax -15 +15 Crosstalk Cancel -8 +8	
	Picture Position	Horiz., Vert.	
	Installation	Lens Control	Focus Zoom Shift Image Pattern On, Off Lock On, Off Lens Memory Select Lens Memory Save Lens Memory Name Edit 10 char. max Lens Center Confirm Lens Cover (Yunzi+2&3) Auto, Open
		Pixel Adjust	Adjust Off, Memory1, Memory2 Adjust Area Whole, Zone Adjust Color Red, Blue Adjust Pattern Color White - Cyan/Yellow Adjust (Pixel) Adjust (Fine) Reset
Installation Style		Front Ceiling Mount (Front) Rear Ceiling Mount (Rear)	
Keystone (vertical)		-16 +16	
Pincushion		0 +16	
Anamorphic		Off (vert. stretch) A (hor. squeeze) B	
High Altitude Mode		(900m or higher) On / Off	
Environment Setting		Adjust On, Off Screen Adjust (Color Profile is not Off) On, Off Screen No. 001 - 106 Screen Size (inch diag.) 60 - 200 Viewing Distance 1m - 10m Wall Color Light - Dark	

PICTURE ADJUST

Display Setup	Back Color	Blue, Black	
	Menu Position	select position	
	Signal Display (active input)	On, Off	
	Logo	On, Off	
	Language	select between 13 languages	
Function	Trigger	Off On (Power) On (Anamorphic)	
	Off Timer (in hours)	1H, 2H, 3H, 4H, Off	
	ECO Mode	On, Off	
	Network	DHCP Client	On, Off
		IP Address	192.168.0.2
		Subnet Mask	255.255.255.0
		Default Gateway	192.168.0.254
		Mac Address	Display MAC
		Set	
		Remote Code	Press [Menu] + [Back]
	Lamp Reset	Confirm	
Information	Input		
	Source		
	Deep Color		
	Color Space		
	Lamp Time		
	PS Version		

7.0 PICTURE ADJUST

7.1 Picture Modes and Color Profiles

The preset Picture Modes are available and they can be applied to any input. A picture mode retains the picture adjustments. When adjusting the Picture Mode, you can also select pre-configured Color Profiles.

Yunzi+1 picture modes

Video Source	Digital Cinema or HDTV	Animation, vivid movies	Dramas or Videos	Live concerts or Spectacles
Picture mode	Cinema	Animation	Natural	Stage
Color Profiles	Cinema	Animation	Natural	Stage
	Standard	Standard	Standard	Standard
	3D Cinema	3D Animation	3D Video	3D Stage

Yunzi+2&3 picture modes

Video Source	Movies in general	Digital Cinema or HDTV	Animation vivid movies	Dramas or Videos	Photos	Live concerts, Spectacles	THX sources
Picture mode	Film	Cinema	Animation	Natural	Photo	Stage	THX
Color Profiles	Film1	Cinema1	Anime1	Video	Adobe RGB	Stage	THX
	Film2	Cinema2	Anime2				
	Film3	Standard	Standard	Standard	Standard	Standard	
	3D Film	3D Cinema	3D Anime	3D Video	3D Photo	3D Stage	3D THX



x.vColor inputs may be correctly decoded when using on of the four available User "Picture Mode" and selecting x.v.Color "Color Profile". The User Picture modes can be renamed to a more convenient name.

There are 12 Color profiles for 2D inputs and 7 for 3D inputs, depending on the selected picture mode, you may choose an available color profile preset:

- Film1 available with Film Picture Profile, uses the Xenon filter and adjusted to Eastman Kodak film tone
- Film2 available with Film Picture Profile, uses the Xenon filter and adjusted to Fujifilm film tone.
- Film3 available with Film Picture Profile, uses the Xenon filter and adjusted to Technicolor film tone.
- Standard will bring rich and saturated colors found in HDTV, available with almost any selected Picture Mode.
- Cinema1 available with Cinema Picture Profile and adjusted to HDTV standards
- Cinema2 available with Cinema Picture Profile and adjusted to DCI standards.
- Anime1 best suited to Hollywood animes.
- Anime2 best suited to Japanese animes.
- Video color profile is best suited to TV and Sport programs.
- AdobeRGB color profile adjusted to Adobe RGB standard.
- Stage best suited to live concert.
- x.v.Color matches the color space of x.v.Color standard.

7.2 Advanced Picture Mode

Clear Black

Smooth out the black areas to obtain clear zone by eliminating electronic white noise in these areas. Turn it Off or set the correction to Low for a mild effect or High for a strong effect.

Lamp Power

Set the lamp power used by the current Picture Profile:

Low: lamp is set to 180W

High: lamp is set to 230W.



To avoid any damage to the lamp, you shouldn't change the lamp power within 90 seconds from the projector startup or 60 seconds after lamp power change.

Lens Aperture

The lens is equipped with a variable electronic aperture. This function is used with a real time analysis of the video picture projected that optically adjusts the light output depending on the viewing conditions by controlling the aperture dynamically: when set to Auto 1, the iris will automatically be set to the optimal opening. Auto 2, the curve is altered so that the gradation is more visible. The Manual setting lock the iris to a fixed position, adjust to the best aperture from partially closed (-15) to fully opened (0).

User Name Edit

You can edit the picture modes names User1 to 4 using a maximum length of 10 characters. You can use alphabet letters, numbers and symbols:

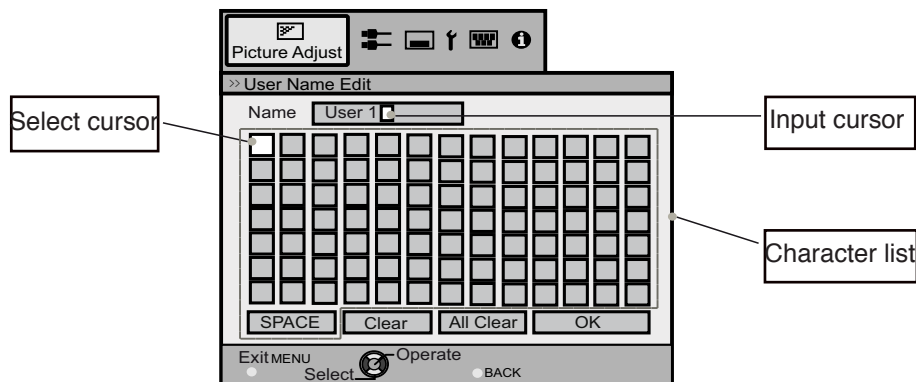

- Select the user name you want to edit from User1 to User5. Press [OK] to enter the edit mode.
- The input cursor displays the place where the new character will be insert. It moves automatically as a character is selected. Use [UP], [DOWN], [LEFT] or [RIGHT] to select a character and press [OK] to insert.
- Press [BACK] to exit edit mode.

Clear: To delete a character: Move the cursor to the desired location and press [OK] to delete the specific character.

All Clear: To delete all characters. OK: To save the current name, a save confirmation will appear.

7.3 Advanced Color Profile

Expert Calibration is accessed only by using a programmable IR-RCU, RS-232C or LAN control. Two additional sets of Picture Modes can be activated. Each set designated as THX and ISF profiles have to be calibrated. Once done, these profiles are stored and displayed in the picture mode menu list but will not be modifiable. Additionally the Calibrator can certify his action by setting in the Information Menu his name or company name.

Color Management (TSL adjustments)

The Color Management gives the installer an unique calibration ease with the integrated Color Adjustment menu: each primary, secondary colors and orange can be independently calibrated to obtain a precise color balance in a snap. Adjust the Red, Green, Blue, Yellow, Cyan, Magenta and Orange Tints, their saturations and luminances and store them into Custom profiles.

7.4 Color Temperature

Color temperature stands for the spectral properties of a light source. Low color temperature implies warmer ambiance (more yellow/red) while high color temperature implies a colder light (more blue). Depending on the Picture Profile selected, this setting can be set to:

- Preset: from 5500K / warm colors, up to 9500K / cold colors in steps of 500K.
- Xenon1(*) uses the Xenon filter and color compensation to reproduce a film projector
- Xenon2(*) uses the Xenon filter and color compensation to reproduce a digital cinema projector
- Xenon3(*) same as Xenon2, but within a cooler temperature.
- High Bright used for maximum brightness output available.
- Custom1, Custom2 and Custom3 can be used to adjust color temperature to specific environment.

A Custom setting allows a fine adjustment of a Color Temperature by selecting it in the Correction Value menu. Adjust the Gain values (bright part) and Offset values (dark part) for each color Red, Green and Blue.



Accurate color temperature may require professional tools such as dedicated software and colormeter. Wait at least 15 minutes after startup before modifying the picture settings.



(*) Xenon Modes are exclusive to Yunzi+2&3 models.

7.5 Advanced Color Temperature

When selecting a Color temperature, you can set the Gains and Offsets of each primary color: red, green and blue to finely adjust the color balance.

7.6 Gamma

Gamma is the relationship between the color values of the data and the color values displayed. The Gamma coefficient makes it possible to adjust the brightness of the midtones only without affecting the very bright and very dark areas. If gamma is set too high, middle tones appear too dark. If it's set too low, middle tones appear too light.

Depending on the current active Picture mode, the Gamma setting can be set to:

- Normal: Standard setting for normal viewing.
- Brightness Priority: Places more emphasis on the brightness than the Normal setting.
- Contrast Priority: Places more emphasis on the contrast than the Normal setting.
- Gradation Priority: Places more emphasis on the gradation than the Normal setting.
- Custom1 to Custom3: fine tune the gamma setting according to the user's preference.
- NB: when Color Profile is set to x.v.Color, gamma setting is fixed to Normal.

Additional Gamma settings when Film Color Profile is selected (Yunzi+2&3):

- Film1: standard gamma
- Film2: slightly more contrasted gamma

7.7 Advanced Gamma

Correction Value

The Custom data can be set to:

Correction Value: a unique value that will act as a gamma coefficient between 1.8 and 2.6, Normal, Brightness Priority, Contrast Priority, Gradation Priority, 1.8-2.6 or Import.

Color Selection

Select the color to which the Picture Tone, Dark / Bright Level settings would apply. Choose between White, Red, Green and Blue.

Picture Tone

It allows a fine adjustment steps of the global picture brightness while maintaining the correct contrast level to keep good black and bright levels. Sets the overall exposure from -16 (under-exposed, darker) up to +16 (over-exposed, brighter)

Dark / Bright Level

This setting modifies the gamma curve locally in the dark and bright areas.

- Dark Level adjust gamma curve between 0IRE and 15IRE, each color can be adjusted from -7 to +7.
- Bright Level adjust gamma curve between 85IRE and 100IRE, each color can be adjusted from -7 to +7.

Reset Gamma

Prompt a confirmation to reset the current Gamma settings to default.

7.8 Multiple Pixel Control Level (MPC Level)

4k e-shift

- On: sets this unit to display the video content in 4K resolution.
- Off: sets this unit to display the video content in Full-HD resolution.

Resolution

Set the resolution according to the content your are viewing between : 1080p, 1080i/720p or 480p. The best setting is Auto. By selecting the Auto setting, this unit will automatically detect and select the correct resolution.

Enhance

Enhance: enhances the sharpness of foreground objects detected in the picture.

Dynamic Contrast

Dynamic Contrast: enhances the general contrast of the picture.

Smoothing

Smoothing: enhances the blurriness of backgrounds for increased the global sense of depth.

Noise Reduction

Noise Reduction: reduces the digital noise of the video picture.

Analysis screen



Analysis screen:

You can enlight the different areas processed by the 4K-Interpolation by pressing [Analysis Screen] button or twice the [MPC Level] button on the RCU when browsing the MPC Level sub menu.

- Areas affected by the Enhance parameter are colored Blue and Green.
- Areas affected by the Dynamic Contrast parameter are colored Red and Yellow.
- Areas affected by the Smoothing parameter are colored Black.

Pressing the [Before/After] button enables you to toggle between the state before adjustment and after adjustment.

7.9 Clear Motion Drive (400Hz)

The Clear Motion function uses a 400Hz video processing to render a smooth and clear motion for movies shot at 24Hz or HD movies at 60Hz. Set the correct level between:

- Off: Frame interpolation is disable.
- Low: light frame interpolation with reduced artifacts.
- High: strong interpolation
- Inverse Telecine: dedicated interpolation for 60i and 60p sources originally shot in 24p.

7.10 Contrast

The contrast function is used to adjust the contrast between the light and dark areas of the displayed image. A correct contrast setting is important for good image reproduction. Adjust the Contrast value between -50 and 50.

7.11 Brightness

The brightness function is used to adjust the overall light output. Adjust the Brightness value between -50 and 50.

7.12 Color

The Color function (or Saturation) is used to adjust the saturation levels. Adjust the Color value between -50 and 50.

7.13 Tint

The hue function is used to adjust the color tint to obtain true color reproduction. Adjust the Tint value between -50 (more red) and 50 (more green).

8.0 INPUT SIGNAL

8.1 Input Level

Sets the dynamic rang of the video input:

- Auto: The input dynamic range is automatically detected and configured.
- Standard: Force dynamic range to 16-235.
- Enhance: Force dynamic range to 0-255.
- Super White: Force dynamic range to 16-255.

8.2 Color Space

Sets the color space of the input signal.

- Auto: The source color space is automatically detected and configured.
- YCbCr(4:4:4): Set color space to YCbCr 4:4:4.
- YCbCr(4:2:2): Set color space to YCbCr 4:2:2.
- RGB: Set color space to RGB 4:4:4.

The color space setting is fixed to YCbCr(4:2:0) for 4K50/60p inputs. Use preferably a video source of 4K24/25p if available to obtain rich colors.

8.3 Control with HDMI (CEC*)

- Off: By default the CEC(*) communications are disabled.
- On: Enables CEC(*) communications to be sent to the projector through HDMI cable.

(*) CEC stands for Consumer Electronic Control

8.4 Aspect Ratio

When watching a movie or video program, you can manually set the desired aspect ratio to fill your screen. Select the correct aspect ratio depending on your source:

For Video sources

- 4:3. The original source is considered as 4:3 format. Generally SDTV broadcasts.
- 16:9. The picture size is 16:9, generally most recent DVDs, Blu-Ray discs or HDTV broadcasts.
- Zoom. The zoom function is useful to zoom in the picture and eliminate black bars.



When watching 3D content, only 16:9 aspect ratio is available.

For PC sources

- Auto. Zoom the picture to fill either the screen height or the screen base which ever happens first.
- 1:1 mode, pixel to pixel mapping, no scaling.
- Full. Stretch the picture full screen

8.5 Progressive (only 480i, 576i, 1080i)

Interlaced signals are converted to progressive signals using video images from the surrounding. This function is only available for interlaced input signals: 480i, 576i and 1080i.

8.6 Mask

Depending on your source, you may enable or disable this feature to hide the outer area of the picture. The Mask function can hide the unexpected scaling artefacts found in broadcast program. You can set it to Off, 2.5% or 5% globally or for each side of the screen.

8.7 Picture Position

Depending on your source, you may find that the picture should be adjusted into the screen, adjust the horizontal and vertical position of the picture into the screen. Some signals may not be fully displayed, adjust this setting properly when necessary.

9.0 3D CONTENT AND 3D PROJECTION

9.1 General Information about 3D playback

Comfort and Caution with 3D Content

The closer one looks at stereoscopic images, the greater the binocular disparity, which means greater perception of outward projection. At the same time, the spectator must focus on these outward objects on the screen. The projecting image and the real focus distance cause a great contradiction, this strain contributes to fatigue and discomfort.



Please stop watching if you do not feel well and consult a physician if necessary. People who already have a kind of photosensitivity, sufferers from heart disease, and people in poor physical condition should not watch 3D stereoscopic images. It is also recommended that you take a break periodically.

Prevent child under 5 years old to watch 3D

The comprehensive brain function to judge stereoscopic vision which includes the feeling for real distances, develops while growing up by touching and seeing real objects, but in early childhood, it is still in an underdeveloped state. Even though there are individual differences, children under 5 are still developing. Letting them frequently watch virtual 3D video images can be an obstacle for the development of a comprehensive three-dimensional feel. Additionally, younger children may suddenly become sick, because they continue watching without realizing symptoms like 3D sickness or deterioration of health. Please accompany your child while it watches 3D programs.

9.2 Projector 3D Settings

3D Formats

Use this function to choose the correct 3D input format. Some input signals may contain 3D data such as 1080p Side-by-Side but encoded as if they were in 2D. This unit may treat them as standard 2D signals and will not project correctly. In such cases, configure the signal manually between Side-by-Side, Top & Bottom and 2D. In other cases, you may select Auto setting.

2D to 3D Conversion

You can use the 2D to 3D Conversion to convert 2D pictures into a quasi-3D picture. The quality of the result may differ from quality of original 2D picture. Turn it On or Off.

Parallax

Use this function to adjust the amount of misalignment of the left and right 3D video images. Adjust settings according to your preference between -15 and +15.



Parallax is an important parameter for 3D movies that directly affects comfort during 3D projection. Because the parallax value changes with the screen size, it is important to set this parameter to a value with which everyone feels comfortable with the 3D effect. In general, women and children will feel better with a smaller parallax value. Do not hesitate to alter this settings if you feel eye-strains or headaches.

Due to the large screens used in home theaters compared to flat screen TVs, we recommend a negative value of -6 for computer sources and video games in native 3D with large parallax. This setting is best at 0 for Blu-Ray movies aimed for Digital-Cinema audience.

Crosstalk Cancel

Can be adjust with a 3D signal input but not when 2D to 3D Conversion is On. This function is to lessen the residual cross-talk found between 3D video images. Adjust the Parallax value and then the Cross-talk settings in order to cancel the residual cross-talk without losing picture quality.

Adjustments White, Red, Green and Blue: -8 +8



Negative values reduce visible Crosstalk, positive values bring a brighter 3D picture at the cost of more Crosstalk.

10.0 INSTALLATION

10.1 Lens Control

Focus

Adjust the lens focus to obtain a clear picture.

Zoom

Adjust the lens zoom to fill the screen with the picture.

Shift

Adjust lens shift to center the picture into the screen.

Image Pattern

If set to On, an internal pattern will be generated to adjust the current setting. If you want to use an external generator, turn this option to Off.

Lock

Once the Lens is correctly set, you may lock this setting menu by turning the Lens control Lock to On. Any attempt to access the Lens control menu will lead to the display of a warning message.

Lens Memory Select

Call up saved lens adjustment data to configure the lens to the save settings.

Lens Memory Save

Store into an available memory the lens focus, zoom and shift configuration. There are 5 memories for Yunzi+1 model and 10 memories for the Yunzi+2&3.

Lens Memory Name Edit

You can edit the Lens Memory Name within the limit of 10 characters. Same procedure as section "User Name Edit", page 19.

Lens Center

Reset the lens position to the original, central position.

Lens Cover (Yunzi+2&3)

Control the behavior of the Lens Cover:

- Auto: the lens cover opens or closes when the projector switches On or Off.
- Open: the lens cover is always open.

10.2 Pixel Adjust

The pixel adjustment is extremely fine: each color can be adjust within 1/16 pixel steps on 121 individual adjustment zones.

Adjust

Enable the pixel adjustment on Memory 1, Memory 2 or Off.

Adjust Area

Whole: the entire screen is selected for adjustment.

Zone: the screen is divided into 121 adjustment zones.

Adjust Color

Select the color to adjust: Red or Blue.

Adjust Pattern Color

Select a pattern to help the pixel alignment. Settings: White or Green+adjusting Color. Yellow for red, Cyan for blue.

Adjust (Pixel)

This function is enable when the Adjust Area is set to Zone only. You can adjust the selected color position horizontally and vertically by 1-pixel steps.

- H settings: -2 +2
- V settings: -2 +2.

Adjust (Fine)

Use this function to move the selected color within smaller steps.

- H settings: -31 +31
- V settings: -31 +31

Reset

Reset all pixel adjustments to default factory settings.



RCU SHORTCUTS DURING PIXEL ADJUSTMENT:

[GAMMA] button on the RCU switches adjust color parameter between Red and Blue.

[PIC. ADJ.] button on the RCU switches the adjust area parameter between whole and zone. At the same time, the zone cursor will appear on the adjust pattern.

[COLOR SPACE] button on the RCU changes the adjust pattern from white to green+adjust color.

Use the [COLOR TEMP] button on the remote control to change adjustment method from Pixel to Fine tune and switch to the fine tune window.

[BACK] button will exit the Pixel Adjust mode.

Installation Style

Flip the image to the left or right, up or down according to the projection state of the projector:
 Front, Ceiling Mount (F), Rear or Rear Ceiling mount (R)

10.3 Keystone (Vertical)

Compensate for trapezoidal distortion caused by installation. Independently to the screen orientation, make sure that the projector is not tilt more than 5% up/down.

- Vertical Keystone from -16 to +16.

10.4 Pincushion

Compensate distortions that may appear with curved screens or anamorphic setups.



NB: When a 3D signal is fed or when Keystone is used, the Pincushion correction cannot be set.

10.5 Anamorphic (works with 3D signal)

- Off: No modification to original picture.
- Mode A: The picture is vertically stretched to fit an installation with anamorphic lens. A cinemascope picture is stretched to completely fill the panels without black bands, using the optimum resolution and brightness.

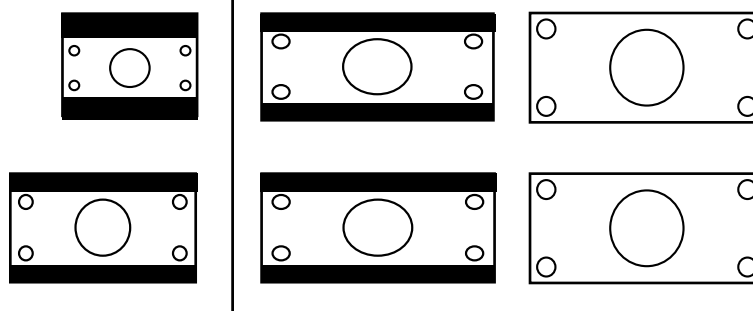

Anamorphic Mode A.

- Mode B: This setting squeezes horizontally the picture to fit a 16:9 image into cinemascope screen. This setting is to be used with an anamorphic installation where the lens is permanently fixed in front of the unit and to watch 16:9 content in its original format.

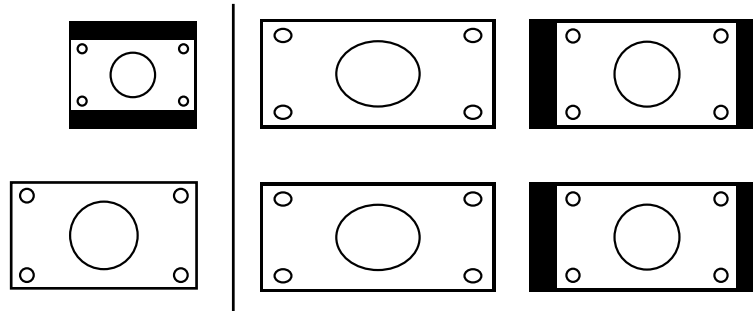

Anamorphic Mode B

10.6 High Altitude Mode

Select this when the projector is in a location of low atmospheric pressure. On or Off

10.7 Environment Setting

Turn On or Off the Environment setting. If set to On and to finely tune the picture, you may change the environment settings so that they match your installation:

- Screen Adjust: This setting corrects the color balance derived from the reflective characteristics of the screen

without altering the global picture settings. You may select the best template available in the Screen No.

- a) 001 - 009: select a profile between 001 and 009 when watching 3D content with 3D shutter glasses. Profile 001 is recommended when using Dreamvision's active IR 3D-glasses.
- b) 010 to 106: select the best compensation profile depending on your screen and environment.
- Screen size: diagonal size in inches set this setting between 60" and 200".
- Viewing distance is the distance to the screen of the nearest seat in meters, set it between 1m and 10m.
- Wall color, select "Dark" if the walls are black or similar, for any lighter shades select "Light".

11.0 DISPLAY SETUP

Back Color

Configures the screen color displayed when there is no active input. Set to Blue or Black.

Menu Position

Upper left, Upper right, Center, Lower right, Lower left.

Signal Display

On: Display the source of the input signals after input selection.

Off: Don't display.

Logo

On: Display D-ILA logo during startup for 5 seconds.

Off: Don't display.

Language

Choose the OSD language between: English, Japanese, German, Spanish, Italian, French, Portuguese, Dutch, Swedish, Norwegian, Russian and Chinese.

12.0 FUNCTION

12.1 Trigger

The 12V trigger output can be used to control any compatible devices such as motorized screens or anamorphic kits: The 12V trigger output is 12Vcc, 100mA. Select the trigger output behavior:

- Off: 12V trigger voltage state is always low.
- On (Power): 12V trigger state is high when the projector is powered ON. To be used with motorized screens.
- On(Anamo): 12V trigger is high only when Anamorphic Mode A or Mode B is engaged. To be used with motorized anamorphic kits.

12.2 Off-Timer

You can configure this automatic power Off function that will switch off the projector when there is no operation or after a determined timer. Choose the duration of the timer between: Off, 1 hour, 2 hours, 3 hours and 4 hours.

12.3 ECO Mode

This setting when set to On will minimize the power consumption in the Standby Mode. Additionally, this product will automatically switch Off whenever the input signal is interrupted for 30min.

12.4 Network

When the Communication Terminal selected is LAN, this unit will be visible on the local Network and the following parameters need to be configured. Refer to section "16.2 LAN protocol", page 37 for more details.

12.5 Remote Code A or B

Select in the projector menu the code A or B according to the code selected on the RCU. You can change the code used by the RCU to communicate with the projector from A to B. To do so, press and hold for 3 sec simultaneously [MENU]+[BACK] buttons on the RCU. All the buttons on the RCU will blink.

- Two blinks indicate that B code is used.
- Three blinks indicate that A code is used.

12.6 Lamp Reset

Resets the lamp use time to “0” during the lamp replacement procedure. See Section “15.3 Replacing the Lamp”, page 31 for more details.

13.0 INFORMATION MENU

Input Terminal

Displays the active video input.

Input Source

Displays the type of the current video input signal.

Resolution

If the active input is PC input., its resolution is displayed.

H. Frequency

In the case of PC signal, the horizontal frequency is displayed.

V. Frequency

In the case of PC signal, the vertical frequency is displayed.

Deep Color Depth

Displays the color bit depth of the input video signal.

Color Space

Displays the color space of the input signal.

Lamp Time

Displays the accumulated hours of usage of the lamp.

Calibrator

Stores up to 18 ASCII characters set by the Calibrator. Shown only if set during ISF profile adjustment.

14.0 CINEMASCOPE SETUPS

14.1 Lens Zoom or 2.35 Theater System kit

The Yunzi+ centralizes the controls and automation commands for a unique, versatile and unexpectedly simple to operate 2.35:1 theatre experience using Lens Zoom or Anamorphic Lens.

- Up to 10 lens position memories
- Integrated Constant Image Width (CIW) scaler with anamorphic mode A and mode B.
- Dedicated commands to control the 2.35 Theater System kit and picture size on a 2.35:1 screen.

14.2 Cinemascope setup with Lens Zoom

Select “Menu => Installation => Lens Memory 1”

Zoom in, until the left and right borders of the picture fits the 2.35:1 screen borders. Save the lens position in the lens memory 1. You can also edit the memory 1 name to “Cinemascope”.

Select “Menu => Installation => Lens memory 2”

Make sure to project a 16:9 picture, zoom out until the picture top and bottom fit the top and bottom of the screen. Adjust the focus and offset if required, then save this position into the memory 2. You can additionally edit the memory name to “Standard”.

Switch format using the Remote Control Unit.

You can now switch between Cinemascope and standard formats easily by using the [Lens Mem]ory button on the RCU and selecting the correct lens memory according to the source format.



Because of the nature of the lens motorization, the precision overtime is not enough to perpetually maintain the correct zoom / focus / position after several zoom in and out. It is required to periodically alter the lens setting.

14.3 Installing a 2.35:1 screen with the 2.35 Theater System kit

Plug the 12V Trigger output of the projector to the Anamorphic motorization

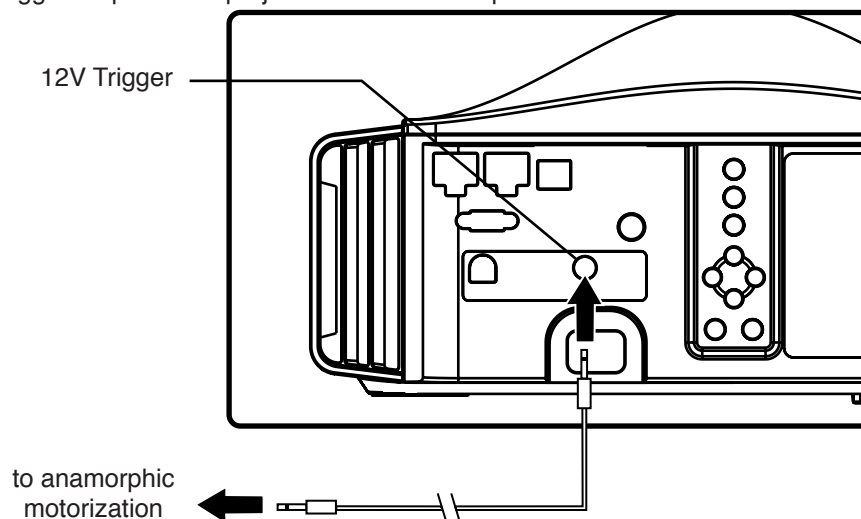

Connect the lens motorization to the 12V Trigger output.

Configure the function “Menu => Function => Trigger => On (Anamo)”

The “Function => Trigger” menu determines the 12V Trigger output located in the panel input at the rear of this unit. This is a global parameter (for all inputs). Set the 12V Trigger to “On (Anamo)” mode so that it is most of the time Off and switches On when the picture is in Cinemascope format and Anamorphic mode A is selected. The picture is then vertically stretched and the lens is needed.

- Set 12V Trigger to: “Function => Trigger => On (Anamo)”.

Video source is 16:9: set [Anamo]rphic to Off

When you select a 16:9 input choose the anamorphic OFF to obtain move the anamorphic lens out. Menu “Installation => Anamorphic => Off”

Video source is Cinemascope: set [Anamo]rphic to Mode A

Select Anamorphic mode A for this input in the menu Input “Installation => Anamorphic => Mode A”.

[Anamo]rphic modes

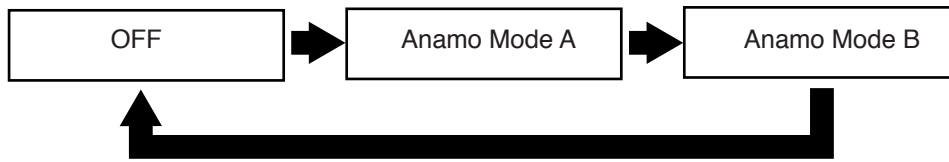

When you press sequentially the [Anamo]rphic button, you change the mode from OFF, Mode A and Mode B.

- Mode A is intended to be used with an anamorphic lens to watch 2.35:1 content on a 2.35:1 screen.
 - Mode B is intended to be used to quickly switch to 16:9 content without moving the anamorphic lens.
- The Anamorphic Lens is automatically placed in front of the projector to restore the correct picture aspect ratio.

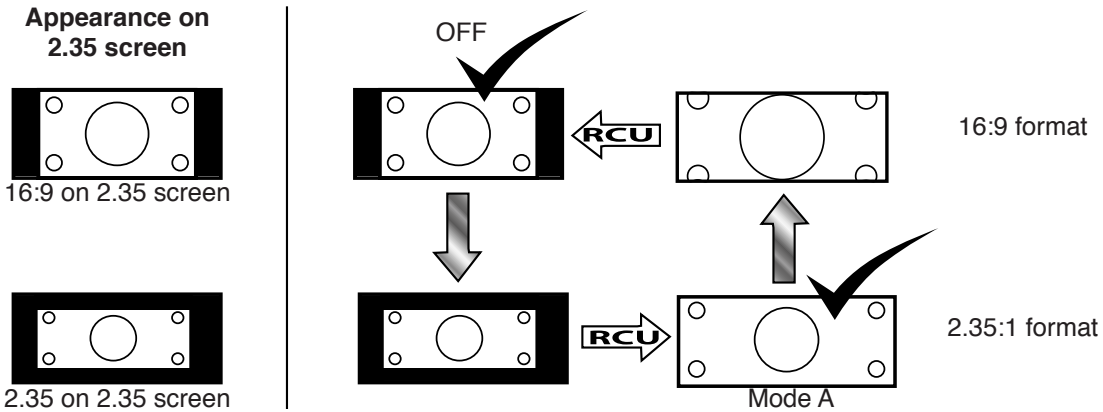

When the source switches format....

... press [Anamo] button to obtain the correct anamorphic mode.

15.0 MAINTENANCE

15.1 Cleaning and Replacing the Dust Filters

The filters must be cleaned regularly to allow an efficient air intake. Otherwise, dirt may enter the unit and appear on the screen, preventing you from enjoying the video fully. If dirt has entered the unit or if you need information about the filter, please consult your authorized dealer. A filter cleaning warning appears every 500 hours.

Cleaning procedure

- Pull out the power plug from the outlet while the projector is in standby mode.
- Push up and lift the claw of the filters, pull out the filters.
- Clean the filters with water and dry them, avoiding direct sunlight. In extremely soiled cases, use of a neutral detergent is recommended. Insert the filters in their original positions and make sure that the claws are firmly inserted.

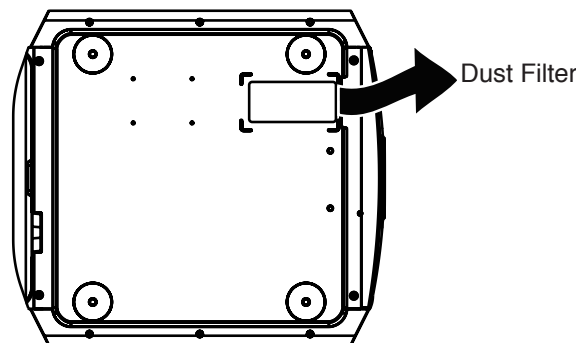

15.2 Dirt on the Lens

The lens shall be cleaned using commercial blowers or lens cleaning papers (for cleaning glasses and cameras). Do not use fluid-type cleaning agents. This may lead to peeling of the surface coating film. The lens surface is fragile. Avoid rubbing it hard or knocking.

15.3 Replacing the Lamp

Light-source Lamp and Lamp Usage Time

The life of light-source lamps used for this unit is about 4000 hours when running this unit in low lamp mode.

- When the lamp power is set to Low, the lamp life is approximately 4000 hours. This average lamp life is not guaranteed and may not reach 4000 hours depending on the operating conditions. Deterioration progresses rapidly when the remaining lamp usage time is short. Get ready or replace with a new lamp when the accumulated usage time exceeds 4000 hours. Depending on the operating conditions, the lamp may have to be exchanged earlier. If the image is dark or if the color tone is abnormal, replace the lamp as soon as possible.
- You can also check the accumulated hours of usage. Please refer to Lamp Time in the Information menu. When the lamp usage time exceeds 2900 hours. The Lamp replacement message will be displayed on the screen the next three projection starts.
- Press the [BACK] button to clear the display.



ABOUT LAMP REPLACEMENT

If this unit is installed in a constricted place, attempting to replace the lamp in that place may cause injury. Move this unit to a place large enough to perform work.

Use only genuine replacement parts for the lamp unit. Otherwise, malfunction may occur. Also, never attempt to reuse an old lamp unit. This may cause marked performance deterioration or lamp blowout, thus leading to unit malfunction. Broken pieces of the lamp outside this unit may also cause injuries during lamp unit exchange.

Do not replace the lamp immediately after this unit has been used. The temperature of the lamp is still high and this may cause a burn. Allow a cooling period of 1 hour or more before replacement.

Before replacing the lamp unit, pull out the power plug from the outlet and wait until the STANDBY/ON led is still light red. Replacing a lamp with the plug connected to the outlet may cause injuries or electric shocks.

Procedure for Lamp Replacement

During the lamp replacement process, you may have access to sensitive parts of the projector.

- Loosen the screw on the lamp trap at the rear of this unit.

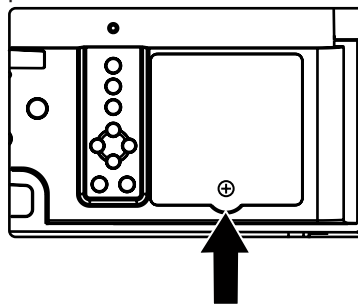

- Open the lamp Cover and loosen the 2 screws on the lamp unit to release it.

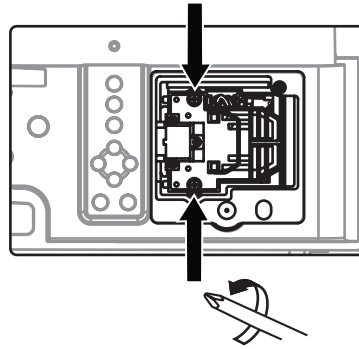

- Pull out the lamp unit using the handle.
- Insert the new lamp unit until it is firmly in place.
- Tighten the screws of the lamp unit.
- Attach the lamp cover and fasten the lamp trap screw.

Resetting Lamp Time

After installing a new lamp, reset the lamp time using the OSD menu
Turn On the unit.

- Browse into the menu Function => Reset Lamp Time.
- Confirm time reset.



CAUTION DURING LAMP RESET

Reset the lamp time only when you have replaced the lamp.
Never reset it when the lamp is still in use. Otherwise, the approximate standard for gauging replacement time may be inaccurate, lamp performance may deteriorate and lamp blowout may occur.

15.4 Troubleshooting

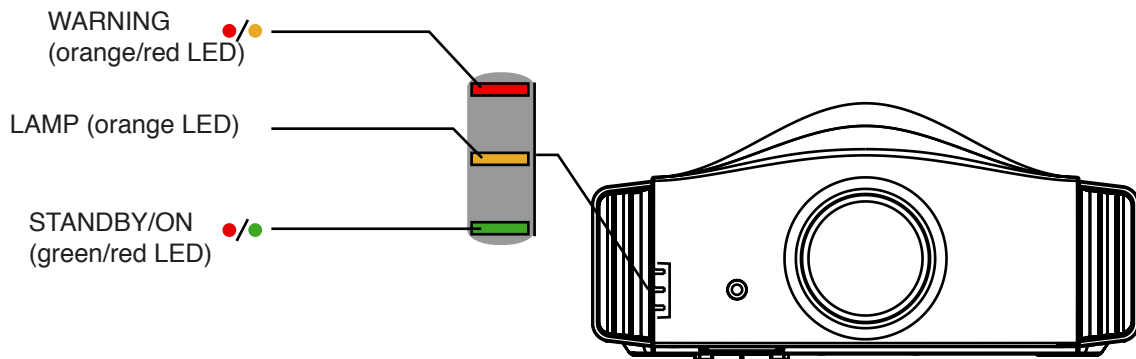

When the projector is running for more than 1 minute, the Standby/ON LED will automatically switch OFF.

ID	Operating LED			Description
	WARNING (orange/red)	LAMP (orange)	STANDBY/ON (green or red)	
1	-	-	red	Unit is in standby mode.
2	-	-	green	Unit is in operate mode.
3	-	-	blinking green	Unit is in operate mode but HIDE is ON. Press again the HIDE button to obtain a picture.
4	-	-	blinking red	Unit is in cooldown mode (switching off).
5/6	-	orange	-	Lamp time has reached 2900 hours, prepare to replace the lamp soon. If used in low power mode, replace the lamp before 4000 hours.

Operating LED				Description
ID	WARNING (orange/red)	LAMP (orange)	STANDBY/ON (green or red)	
7	continuous red	blinking orange	-	blinks 1 time: the lamp failed to ignite, restart the projector after a complete cooldown cycle.
8				blinks 2 times: lamp has shut down during projection, restart the projector after a complete cooldown cycle.
9				blinks 3 times: lamp cover is open. Check that the lamp cover is firmly closed.
10	blinking orange	-	-	blinks 1 time: PSU failed.
11				blinks 2 times: Cooling fans stop.
12				blinks 3 times: Internal thermal sensor detects overheating.
13				blinks 4 times: External thermal sensor detects overheating.
14	blinking red	blinking orange	-	blinks 1 time: Startup or drive circuits failed.
15				blinks 2 times: Communication with drive circuit failed.
16				blinks 3 times: Scaler circuit failed.
17				blinks 4 times: Electrical lens cover failure.



CAUTION: When in Cool Down mode, do not pull out the plug from the outlet. Also, do not block the air inlets/exhaust vents by standing the projector on its end or laying it on its side.

16.0 MISCELLANEOUS

16.1 RS-232C protocol

Serial communication specifications

Control of this unit is possible using a computer or automation device connected with a RS-232 cross cable (female - female D-sub 9 pins cable) or LAN/ RJ-45 cable. Communication specifications for this unit are as follows:

Baud Rate	19200 bps
Data Format	Binary
Mode	Asynchronous
Parity	None
Start Bit	1 bit set to high
Stop Bit	1 bit set to low
X on/off	None
Flow Control	None

RS-232C pin assignment

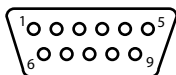

Pin	Signal	Function	Signal Direction
2	RxD	receive data	PC -> Projector
3	TxD	transmit data	Projector -> PC
5	GND	ground	-
1, 4, 6-9	NC	-	-

Command Format

Header 1	Header 2	Command	Command Data	End of Data
21h	89h 01h	2 - 4 bytes	variable	0Ah

Header 1 : 21h for operating commands or 3Fh for reference command.

Header 2 fixed to 89h 01h

Commad: from 2 to 4 bytes length

Command Data: variable length

End of Data fixed to 0Ah

Available Operating commands

Function	Command	Command Data	Description
Connection RS-232	00h 00h	none	Check the serial connection
Power	50h 57h	31h	Switch the unit On.
		30h	Switch the unit in standby mode.
Inputs	49h 50h	36h	Switch active input to HDMI1
		37h	Switch active input to HDMI2
RCU code	53h 55h 52h 43h	30h	Set unit to receive commands from code A
		31h	Set unit to receive commands from code B
Power /w confirm	52h 43h	37h 33h 30h 35h	Switch this unit On.
		37h 33h 30h 36h	Switch this unit Off. (send twice)
Switch input	52h 43h	37h 33h 30h 38h	Switch to next input
		37h 33h 37h 30h	Switch input to HDMI1
		37h 33h 37h 31h	Switch input to HDMI2
Keypad	52h 43h	37h 33h 30h 31h	UP
		37h 33h 30h 32h	DOWN
		37h 33h 30h 33h	BACK
		37h 33h 32h 45h	MENU
		37h 33h 32h 46h	OK
		37h 33h 33h 34h	RIGHT
		37h 33h 33h 34h	LEFT
Hide Display	52h 43h	37h 33h 31h 44h	Toggle Hide On/Off
		37h 33h 44h 30h	Switch Hide to On
		37h 33h 44h 31h	Switch Hide to Off
OSD Menu Position	52h 43h	37h 33h 34h 32h	Toggle the OSD menu position
Lamp Power	50h 4Dh 4Ch 50h	30h	Set Lamp power to Normal
		31h	Set Lamp power to High
Clear Black	50h 4Dh 41h 4Eh	30h	Off
		31h	Low
		32h	High
400Hz CMD	50h 4Dh 43h 4Dh	30h	Off
		33h	Low
		34h	High
		35h	Inverse Telecine
Picture Mode	50h 4Dh 50h 4Dh	30h 30h	Film Mode
		30h 31h	Cinema Mode
		30h 32h	Animation Mode
		30h 33h	Natural Mode
		30h 34h	Stage Mode
		30h 36h	THX Mode
		31h 32h	Photo Mode
		30h 42h	4K 50/60p
		30h 43h	User 1
		30h 44h	User 2

Function	Command	Command Data	Description
Picture Mode	50h 4Dh 50h 4Dh	30h 35h	User 3
		30h 46h	User 4
Color Profile	50h 4Dh 50h 52h	30h 30h	Off
		30h 31h	Film1
		30h 32h	Film2
		31h 33h	Film3
		30h 33h	Standard
		30h 34h	Cinema1
		30h 35h	Cinema2
Color Profile	50h 4Dh 50h 52h	30h 36h	Anime1
		30h 37h	Anime2
		30h 38h	Video
		30h 39h	x.v.Color
		30h 41h	Adobe
		30h 42h	Stage
		30h 45h	Custom1
		30h 46h	Custom2
		31h 30h	Custom3
		31h 31h	Custom4
		31h 32h	Custom5
		31h 45h	3D film
		30h 43h	3D Cinema
		31h 34h	3D Video
		31h 35h	3D Anime
		31h 46h	3D Stage
31h 36h	3D Photo		
Set User1 name	50h 4Dh 55h 31h	10 ASCII char.	Set custom name to User1 Picture Mode
Set User2 name	50h 4Dh 55h 32h	10 ASCII char.	Set custom name to User2 Picture Mode
Set User3 name	50h 4Dh 55h 33h	10 ASCII char.	Set custom name to User3 Picture Mode
Set User4 name	50h 4Dh 55h 34h	10 ASCII char.	Set custom name to User4 Picture Mode
Expert Calibration (THX)	52h 43h	37h 33h 43h 36h	THX plus - On and Adjust
		37h 33h 43h 37h	THX plus - Off
		37h 33h 43h 38h	THX plus - On locked
		37h 33h 38h 35h	Switch Picture Mode to THX - Bright
		37h 33h 38h 36h	Switch Picture Mode to THX - Dark
Expert Calibration (ISF)	52h 43h	37h 33h 35h 38h	ISF - On and Adjust
		37h 33h 35h 41h	ISF - Off
		37h 33h 35h 42h	ISF - On locked
		37h 33h 36h 34h	Switch Picture Mode to ISF - Day
		37h 33h 36h 35h	Switch Picture Mode to ISF - Night
Set Calibrator name	50h 4Dh 43h 49h	18 ASCII char.	Set Calibrator name - ISF must be "Adjust"
Contrast	50h 4Dh 43h 4Eh	4 bytes integer	Set contrast to +10 -> 30h 30h 30h 41h +15 -> 30h 30h 30h 46h -1 -> 46h 46h 46h 46h -15 -> 46h 46h 46h 31h
Brightness	50h 4Dh 42h 52h	4 bytes integer	same as Contrast
Color	50h 4Dh 43h 4Fh	4 bytes integer	same as Contrast
Tint	50h 4Dh 54h 49h	4 bytes integer	same as Contrast

Function	Command	Command Data	Description
Aspect Ratio	49h 53h 41h 53h	30h	Aspect Ratio set to 4:3
		31h	Aspect Ratio set to 16:9
		32h	Aspect Ratio set to Zoom
		33h	(PC) Auto
		34h	(PC) Just
		35h	(PC) Full
Anamorphic Modes	49h 4Eh 56h 53h	30h	Turn Off the Anamorphic mode
		31h	Anamorphic mode set to Mode A
		32h	Anamorphic mode set to Mode B
Select 3D mode	49h 53h 33h 44h	31h	3D mode set to Auto
		33h	3D mode set to Side by Side
		34h	3D mode set to Top & Bottom
		30h	3D mode is disable (force 2D mode)
3D Left / Right phase	49h 53h 33h 50h	30h	Standard phase L/R
		31h	Inverse phase R/L
2D-3D conversion	49h 53h 33h 43h	30h	2D to 3D conversion is Off
		31h	2D to 3D conversion is On

Lens Control

Function	Command	Command Data	Description
Lens Shift	49h 4Eh 31h 55h	none	Shift the picture upward
	49h 4Eh 31h 44h	none	Shift the picture downward
	49h 4Eh 31h 52h	none	Shift the picture to the right
	49h 4Eh 31h 4Ch	none	Shift the picture to the left
Lens Focus	49h 4Eh 31h 46h	none	Focus far
	49h 4Eh 31h 4Eh	none	Focus near
Lens Zoom	49h 4Eh 31h 57h	none	Zoom wide
	49h 4Eh 31h 54h	none	Zoom tele
Keystone	49h 4Eh 4Bh 56h	4 bytes integer	Vertical Keystone (same as Contrast)
Intelligent Aperture	50h 4Dh 44h 49h	30h	Off
		31h	Auto1
		32h	Auto2
Lens Memory	52h 43h	37h 33h 44h 34h	Switch between lens memories
Lens Memory Select	49h 4Eh 4Dh 4Ch	30h	Select Lens Memory 1
		31h	Select Lens Memory 2
		...	
		39h	Select Lens Memory 10
Set Memory1 name	49h 4Eh 4Dh 31h	10 ASCII char.	Set custom name to Lens Memory1
Set Memory2 name	49h 4Eh 4Dh 32h	10 ASCII char.	Set custom name to Lens Memory2
	...		
Set Memory9 name	49h 4Eh 4Dh 39h	10 ASCII char.	Set custom name to Lens Memory9
Set Memory10 name	49h 4Eh 4Dh 41h	10 ASCII char.	Set custom name to Lens Memory10

Examples

You want to...	Command to send
Switch this unit On	send: 21h 89h 01h 50h 57h 31h 0Ah receive: 06h 89h 01h 50h 57h 0Ah

You want to...	Command to send
Switch this unit Off	send: 21h 89h 01h 50h 57h 30h 0Ah receive: 06h 89h 01h 50h 57h 0Ah
Change active Input to HDMI2.	send: 21h 89h 01h 49h 50h 37h 0Ah or send: 21h 89h 01h 52h 43h 37h 33h 37h 31h 0Ah
Change Lens Memory1 name to "TV-size" (unused character are filled with space = 20h)	send: 21h 89h 01h 49h 4Ch 4Dh 31h 0Ah receive: 06h 89h 01h 49h 4Ch 4Dh 31h 0Ah send: 54h 56h 2Dh 73h 69h 7Ah 65h 20h 20h 20h receive: 06h 89h 01h 49h 4Ch 4Dh 31h 0Ah

16.2 LAN protocol

LAN / RJ-45 communication specification

The network settings may have to be modified in the projector's network menu to match your current LAN network.

- DHCP Client: When set to ON, the projector's IP address will be automatically set by the DHCP server. on the LAN.
- IP Address: Sets the IP (Internet Protocol) address of the projector. A valid address must be set for this unit.
- Subnet Mask: Sets the Subnet Mask
- Default Gateway: Sets the Default IP Gateway of the projector.
- MAC Address: A 6 byte hex number that uniquely identifies the projector on the LAN. The value is unique to each individual unit on the LAN network.

Sending a LAN Control Command

In order to send a Remote Control compatible command to this unit, you must open a TCP connection on port 20554. and send a command immediately as the connection will be dropped within 5 sec of inactivity. If for any reason you have to change the TCP connection port, you may use the following RS-232c/LAN command.

[4Ch 53 50h 54h] + 4 ASCII chars as new port address in hexa

You want to set TCP port to 10000	Command to send
Send 10000 as new TCP port value: 10000 is 2710h in hexa, converted in ASCII characters: 32h 37h 31h 30h	send: 21h 89h 01h 4Ch 53h 50h 54h 32h 37h 31h 30h 0Ah receive: 06h 89h 01h 4Ch 53h 0Ah
Then, reboot Network module	send: 21h 89h 01h 4Ch 53h 52h 53h 0Ah receive: 06h 89h 01h 4Ch 53h 0Ah

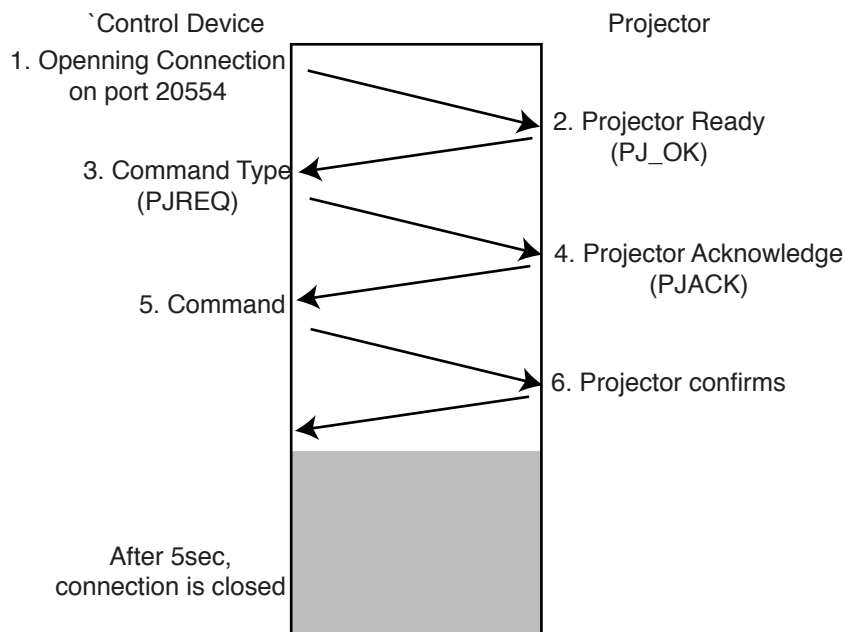

LAN communication protocol and timed out

16.4 Specifications

Overview

Overview

The Yunzi+ uses the latest technology developed to provide the ultimate video-projection experience. LCoS (Liquid Crystal on Silicon) technology based on a reflective principle features an extremely high-definition picture and seamless color gradations.

Emission method	LCoS (Reflective Active Matrix Principle)
Display panel size	0.7" LCoS panels
Display Resolution	3840 x 2160 pixels (3D video is rendered in 1920 x 1080)
Contrast ratio	60,000:1, 120,000:1 and 150,000:1
Projection lens	Throw ratio 1.4:1 - 2.8:1 with 2x Zoom Electronic zoom, focus and shift. Electronic aperture control (16x steps Aperture)
Brightness	1300 ANSI Lumens
Screen size	60" to 250" (Aspect ratio 16:9)
Distance range	from 150cm to 1200cm
Inputs:	
HDMI 1 input	with HDCP and CEC
HDMI 2 input	with HDCP and CEC
Color Management	Advanced color settings (7-axis: primaries, secondaries and orange)
Video Processing	MPC v2.0 with Detail Enhancement, BG Blur and True-4K rendition. 2x Full HD frames per picture with advanced 1/16 pixel alignment
Light source lamp	230W NSH
Power Requirements	100V - 240V AC, 50Hz/60Hz
Power Consumption	<360W (0.4W in standby mode)
Unit size (W x D x H)	46 x 51 x 22 cm - 18.1" x 20.1" x 8.7" (excluding feet)
Net Weight	14,3 Kg - 31.5 lbs for Yunzi+1 15,1 Kg - 33.3 lbs for Yunzi+2&3
Box size (W x D x H)	58 x 61 x 41cm - 22.8" x 24.0" x 16.1"
Gross Weight	20 Kg - 44.1 lbs for Yunzi+1 21 Kg - 46.3 lbs for Yunzi+2&3
Operation Environment	Temperature: 5°C to 35°C (Storage Temperature: -10°C to 60°C) Humidity: 20% to 80% without condensation

- Design and specifications are subject to change without prior notice.
- Please note that some of the pictures and illustrations may have been abridged, enlarged or contextualized in order to aid comprehension. Images may differ from the actual product.



3-CHIP LCoS SYSTEM

LCoS is the abbreviation of Liquid Crystal on Silicon. The 3-Chip LCoS systems feature dedicated panels for each color channel and render seamless color gradations without any flickering or rainbow effect artifacts

Dimensions

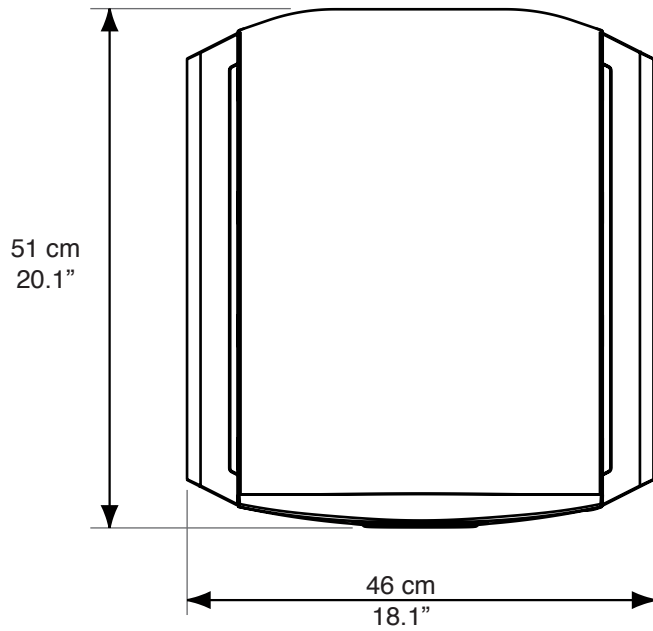
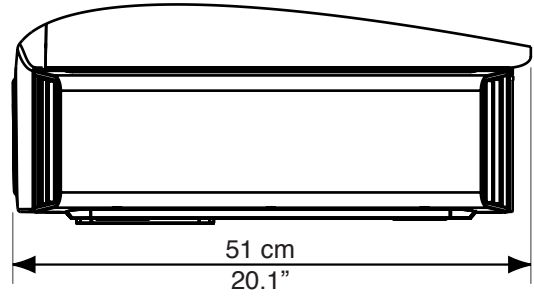
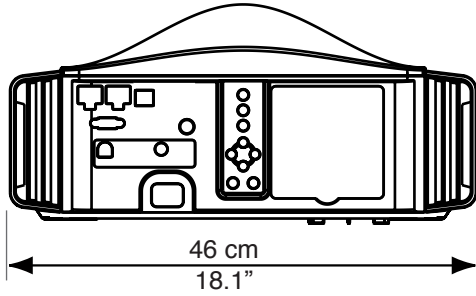
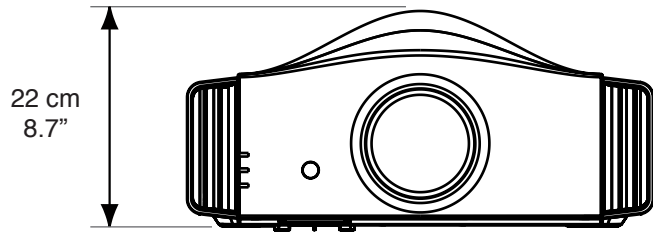

Operating the 3D-Glasses

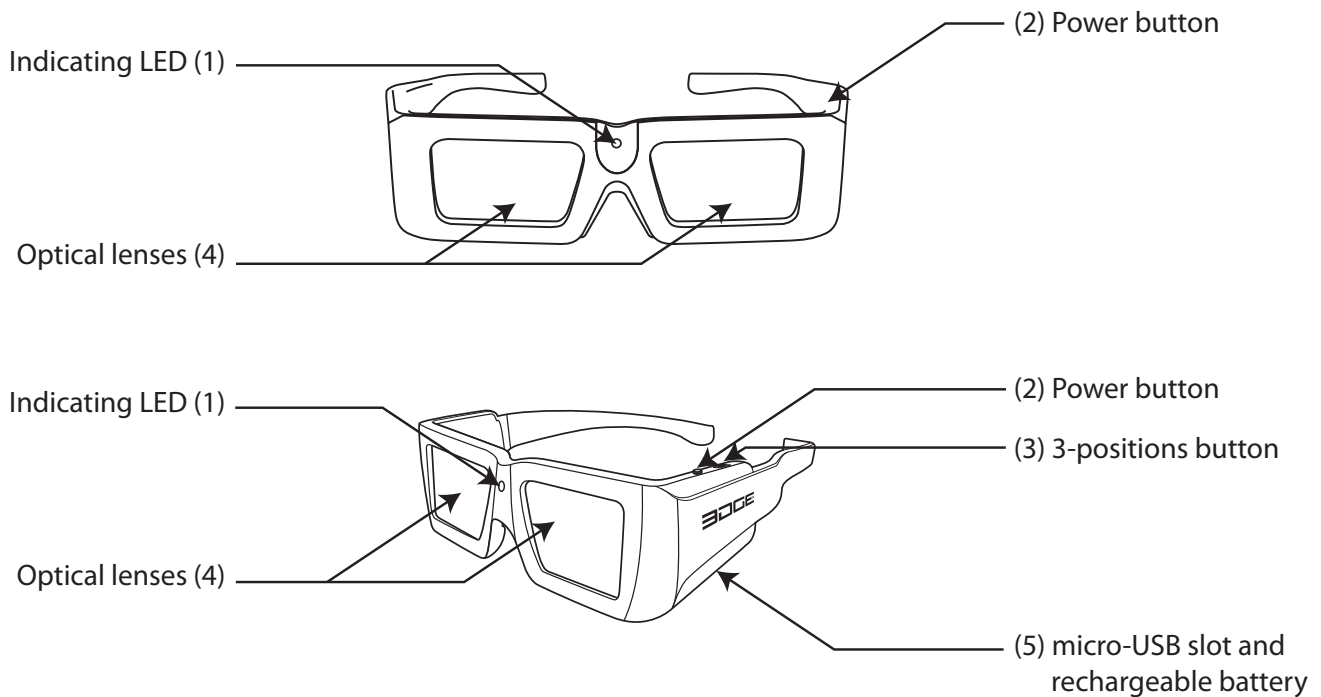

1. Charging the 3D-Glasses

The 3D-Glasses come with a USB-rechargeable battery (5) that is charged using the USB to micro-USB cable. Connect the cable to the micro-USB slot. The indicating LED (1) will light On red continuously during the charge. The Glasses are fully charged when the indicating LED (1) switches OFF.

2. Turning On your 3D-Glasses

- a. Press the Power Button (2) once.
- b. The indicating LED (1) will light ON red and the 3D-Glasses are ready to synchronize with the projector.

3. Turning Off your 3D-Glasses

To turn Off the glasses, press the Power Button (2) during 3 seconds until the indicating LED (1) switches off.

4. 3D-Glasses battery power

The battery allows up to 75 hours of continuous power. When the battery power is low, the lenses (4) will flash slowly (1 second) when the 3D-Glass is powered On.

5. How to use the 3-positions button (3)

The 3-positions button (3) is used to select a functioning mode. By default, the glasses are configured to function with 3D pictures. You can select with the 3-positions button to either watch only left pictures on both eyes or only the right pictures on both eyes of the glass.

6. Efficiency

The 3D-Glasses are programmed to automatically stop functioning after 5 minutes of immobilization. To turn them back On, just press the Power Button (2) once.

Dream Vision

WE MAKE THE WORLD DREAM

Yunzi+ Series - R699840