

## LIN-ACHD-XX Linear Actuator Manual

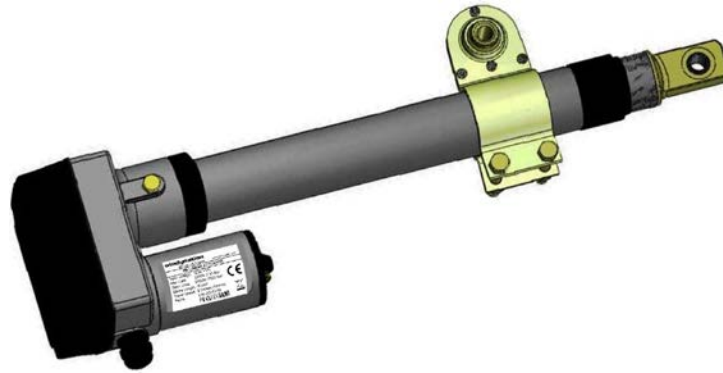

SPECIFICATIONS	LIN-ACHD-18	LIN-ACHD-24	LIN-ACHD-36
Stroke Length	18" (457mm)	24" (607mm)	36" (914mm)
Overall Length	30.7" (780mm)	34.6" (880mm)	46.5" (1180mm)
Dynamic Load	500 lbs (2000N) @ 12VDC - 750 lbs (3000N) @ 24VDC		
Static Load	1500 lbs (6000N)		
Travel Speed (Max)	0.2 in/sec (5 mm/sec)		
Rated Voltage	12VDC / 24VDC		
Current Draw Max	≤ 2.5A		
Mounting Holes	0.51" (13mm)		
Limit Switches	Adjustable		
Operation Temperature	-14.8°F to +149°F (-26°C to +65°C)		
Protection Class	IP65		
Duty Cycle	20%		

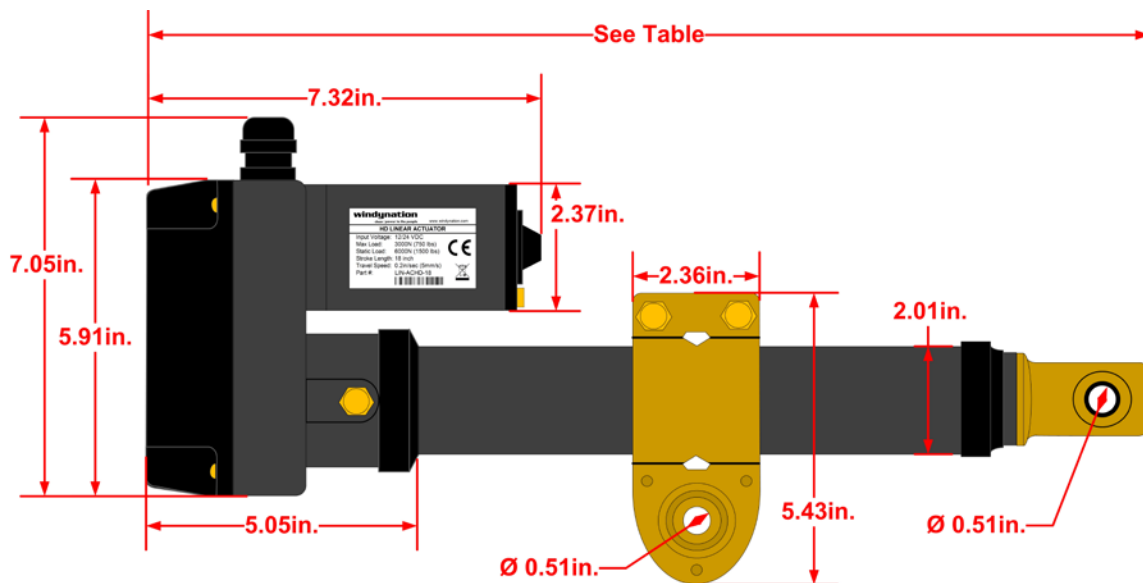

### INSTALLATION

- WARNINGS:**
1. The load added onto the actuator must be less than or equal to the rated load of the actuator.
  2. The moving load must be centered above the extension tube. Off-centered loads will cause additional friction that can exceed the rated load of the actuator.
  3. Do not exceed 20% duty cycle: If the actuator is used at full load for 2 minutes, then it must remain off for 8 minutes. Exceeding the duty cycle will cause the actuator motor to overheat.

### WIRING

**NOTE:** A 10A fuse is recommended in the DC positive (+) connection to protect the actuator from damage.

1. Remove the housing cover on the bottom of the linear actuator by removing the four screws.
2. Run two 16 gauge stranded wires to be used to power the motor through the locking grommet (red and black shown)

- Connect the DC positive (+) power wire to terminal 1 and the DC negative (-) power wire to terminal 2 on the terminal block as shown below.

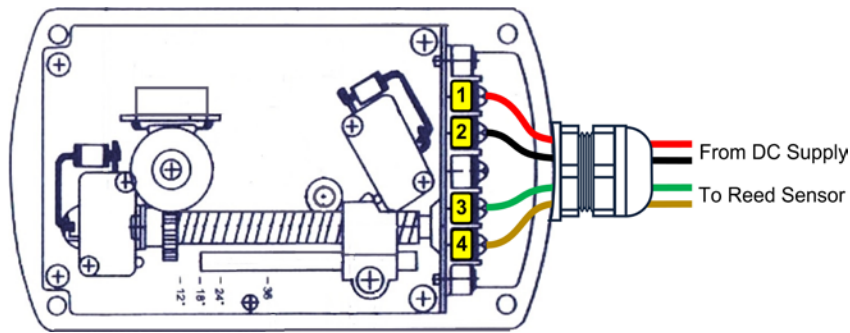

- Apply 12/24VDC to move the actuator; if the actuator moves in the direction opposite to that intended, reverse the red and black wires.

**Reed Sensor (Optional)**

- Run two 22 gauge stranded shielded motor sensor wires through the locking grommet (green and brown shown).
- Connect the sensors pulse and ground to terminals 3 and 4 as shown above.
- Do NOT connect the 24-36V DC motor wires of the positioner to the reed sensor switch.

**MOUNTING**

- Secure or remove the load before installation and ensure the mounting structure can support the maximum possible load.
- Put the actuator in the retracted position to position the load accurately with respect to the lifting screw centerline. Never pull the translating tube to one side to make connection with your structure. Fully extend the actuator to make sure the load is aligned with the translating tube.
- Mount the actuator by securing the top mounting hole to a fixed position using 12mm diameter bolts. The stroke length of the actuator (e.g. 18") and the limitations of the particular application will determine the location of the fixed mounting positions.
- Locate the included electroplated mounting hardware (saddle clamp and two 12mm bolt assembly). The saddle clamp allows the actuator to be mounted at any position along the length of the tube, which helps to accommodate a variety of mount types.
- Slide the clamp down the shaft of the actuator to the desired mounting location on the shaft. The exact mounting location on the shaft will depend on the mounting configuration of the end user. After the clamp is in the desired the location, securely tighten the two nut/bolt pairs on the clamp. This will securely compress the clamp on to the shaft of the actuator

**IMPORTANT:** Confirm up/down movement of actuator is smooth and within actuators stroke length after installation.

**Alignment - Clearance**

Use enclosed spacers or several flat washers (not included) to create the correct alignment and clearance as follows:

- Between the rod end and the antenna mount.
- Between the bracket and the antenna mount.

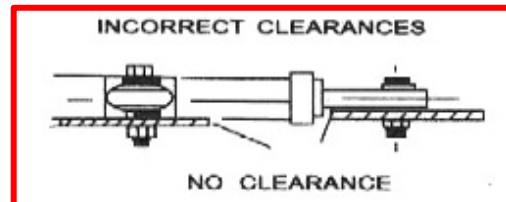
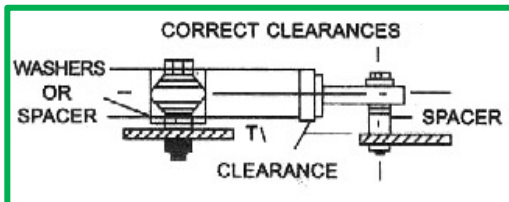
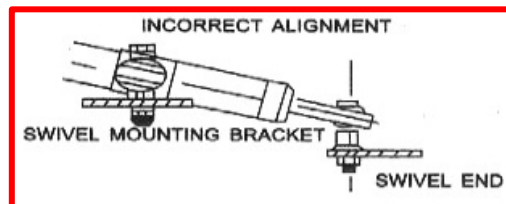
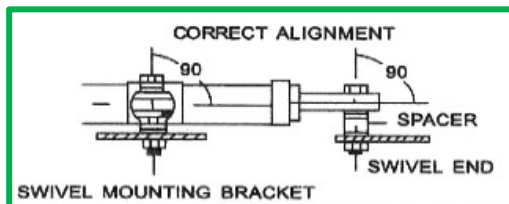

**DAMAGE RESULTING FROM FAILURE TO FOLLOW THE ABOVE INSTRUCTIONS WILL VOID WARRANTY.**

**OPERATION**

**WARNINGS:** The shaft will spin clockwise or counter clockwise when powered if it is not mounted to a fixed structure. Do not allow this to occur as this will change the limit switch settings and can damage the linear actuator. To avoid damage, mount the actuator before powering it up or secure the actuator shaft from rotating with a screwdriver.

The operation of the linear actuator should be tested manually after the installation is completed. Use caution to ensure that:

- The travel distance of the actuator satisfies the requirement of the structural design.
- The extended and retracted limit switches operate normally (motor stops when extension tube is fully retracted or fully extended)
- If the motor runs too slow or does not give full force, (1) the power supply is insufficient and needs to be increased or (2) the load being applied to the actuator is too great and needs to be reduced.

**LIMIT SWITCH – STROKE LENGTH ADJUSTMENT**

**CAUTION:** Adjustment of limit switches on a linear actuator requires basic knowledge of geared electric motor functions. End users lacking this knowledge are strongly advised to seek professional help when adjusting limit switches. Failure adjusting limit switches properly can result in permanent damage to the linear actuator that is not covered under Windy Nation's warranty.

**NOTE:** The limit-switches are factory-set for maximum stroke-length and protection of the motor unit against over-extending. Do not run the actuator until the limits switches are set properly (if the limit switches have been adjusted).

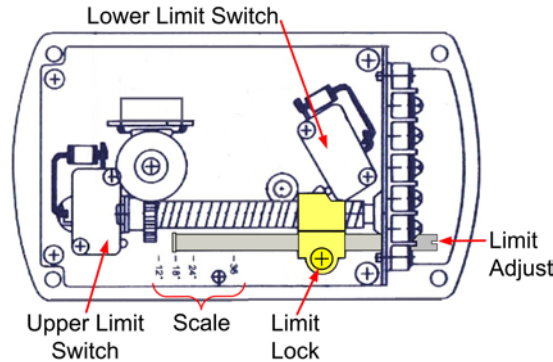

**Check Upper Limit**

1. If the actuator reaches the farthest extension point:
  - a. Remove the housing cover on the bottom of the linear actuator by removing the four screws.
  - b. Loosen the limit Lock screw as shown so the Limit Adjust can move freely, but do not remove.
  - c. Very slowly turn the Limit Adjust counter-clockwise (i.e. moving towards the upper limit switch) ¼ turn.
  - d. Tighten the limit Lock screw and replace the housing cover.
2. If the actuator cannot reach the farthest extension point:
  - a. Remove the housing cover on the bottom of the linear actuator by removing the four screws.
  - b. Loosen the limit Lock screw as shown so the Limit Adjust can move freely, but do not remove.
  - c. Loosen the limit cam screw, but do not remove.
  - d. Very slowly turn the Limit Adjust clockwise (i.e. Moving away from the upper limit switch) in small increments to extend the actuator slowly. Do not allow the actuator to extend all the way out.
  - e. Check to see if the actuator can now reach the farthest extension point. If it can, follow procedures in step 1 to set the upper limit. If it does not you may need a longer actuator.
  - f. Tighten the limit Lock screw and replace the housing cover.

**FORWARD – REVERSE SWITCHING**

A double pole-double throw (DPDT) rocker switch can be wired to swap the polarity on the wires going to the motor and control the extension and retraction of the actuator. This is achieved by making the connections between the switch (sold separately), the power source (e.g. battery or DC power supply), and the actuator wires as follows.

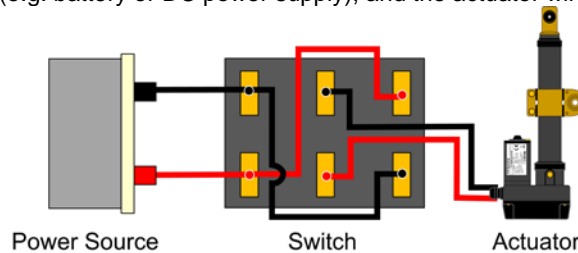

**TROUBLESHOOTING**

Unit will not extend/retract or stops in mid stroke

POSSIBLE CAUSE	CORRECTIVE ACTION
Motor Failure	Use ohmmeter to check resistance of the coil.
Bad Connection	Inspect for broken or loose wires between the power source and the actuator. If a switch is being used check connections between the switch and the actuator/power source.
Thermal Overload Open	If run at a duty cycle greater than 20% or unit is overloaded, the thermal overload in the motor may open to protect the motor. Allow motor to cool and overload to reset. Confirm the application to ensure that the unit is not overloaded and that it is not running at greater than 20% duty cycle.
Insufficient Current	Power may be reaching the motor, but with insufficient current to provide full load moving capacity. Use an amp meter to confirm that sufficient current is reaching the actuator.
Overloaded Clutch Slipping	When a unit is overloaded, the clutch will slip generating a ratcheting noise within the unit. Reduce the load to within specifications and ensure the clutch has not been worn out.
Limit switches improperly set	Review the limit switch adjustment process and correct so that the unit travel is set properly.

**WARRANTY**

Windy Nation warrants the item to be free of manufacturing flaws for a period of 90 days. Windy Nation is not responsible for any injuries and/or damages caused as a result of not complying with the specifications stated.