

reflecta®

x4-Scan

USER
MANUAL

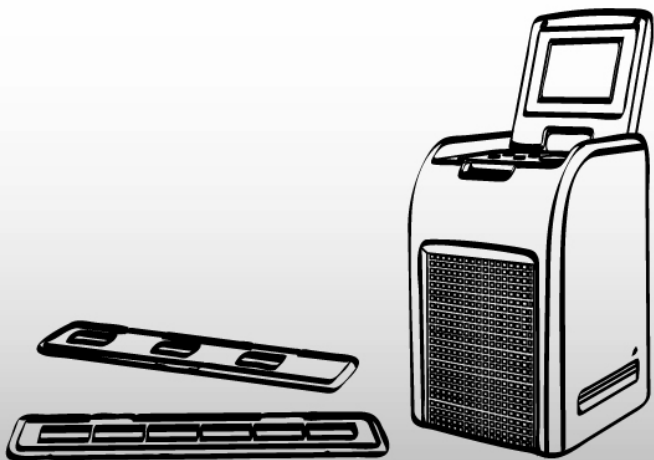

Table of Contents

1.	Precaution	2
2.	Preparation	5
	● Standard Accessories	5
	● Part Names.....	6
	● Installing the Battery Pack	8
	● Charging the Battery Pack.....	9
3.	Place Film/ Slide Into The Holder.....	11
4.	Using the reflecta x4-Scan	12
5.	Playback Mode	18
6.	Delete Mode	19
7.	To Link the Card to Computer.....	21
8.	Edit the Pictures.....	24
9.	Appendix.....	31
	● Specifications.....	31
	● Icon & Indicators.....	32
	● System Requirements.....	33

Welcome

Thank you for purchasing a reflecta x4-Scan.

Please take a moment to read through this manual. Its contents will send you on an educational journey into your recorder multiple capabilities.

1. Precaution

Before using reflecta x4-Scan, please ensure that you read and understand the safety precautions described below. Always ensure that the reflecta x4-Scan is operated correctly.

- Never operate reflecta x4-Scan inside of an aircraft or anywhere else where operation of such devices is restricted. Improper use creates the risk of serious accident.
- Do not try to open the case of reflecta x4-Scan or attempt to modify reflecta x4-Scan in any way. High-voltage internal components create the risk of electric shock when exposed. Maintenance and repairs should be performed only by authorized service providers.
- Keep reflecta x4-Scan away from water and other liquids. Do not use reflecta x4-Scan with wet hands. Never use reflecta x4-Scan in the rain or snow. Moisture creates the danger of fire and electric shock.
- Keep reflecta x4-Scan and its accessories out of the reach of children and animals to prevent accidents or damage to the reflecta x4-Scan.

If you notice smoke or a strange odor coming from reflecta x4-Scan, turn the power off immediately. Take reflecta x4-Scan to the nearest authorized service center for repair. Never attempt to repair reflecta x4-Scan on your own.

- Use only the recommended power accessories. Use of power sources not expressly recommended for reflecta x4-Scan may lead to overheating, distortion of the equipment, fire, electrical shock or other hazards.
- reflecta x4-Scan may become slightly warm during use. This does not indicate malfunction.
- If the exterior of reflecta x4-Scan needs cleaning, wipe it with a soft, dry cloth.

FCC Notice

This equipment has been tested and found to comply with the limits for a Class B Digitize device, pursuant to Part 15 of the FCC Rules. These limits are designed to provide reasonable protection against harmful interference in a residential installation. This equipment generates, uses and can radiate radio frequency energy. If not installed and used in accordance with the instruction, it may cause harmful interference to radio communication. However, there is no guarantee that interference will not occur in a particular installation. If this equipment does cause harmful interference to radio or television reception, which can be determined by turning the equipment on the off, the user is encouraged to try to correct the interference by one or more the following suggestion.

- Reorient or relocate the receiving antenna.
- Increase the distance between the equipment and the receiver.
- Connect the equipment to a different power outlet other than the one where the receiver is connected.
- Consult an experienced television or radio technician for help.

CAUTION

To comply with the limits for a Class B Digitize device, pursuant to Part 15 of the FCC Rules, this device must only be installed on computer equipment certified to comply with the Class B limits.

Standard Accessories



reflecta x4-Scan



QOG

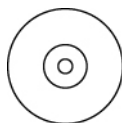

CD



Slide Holder



Negative Holder



Clean brush



USB cable

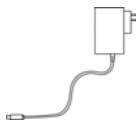

Adaptor
(Optional)

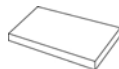

Lithium Battery

Part Names

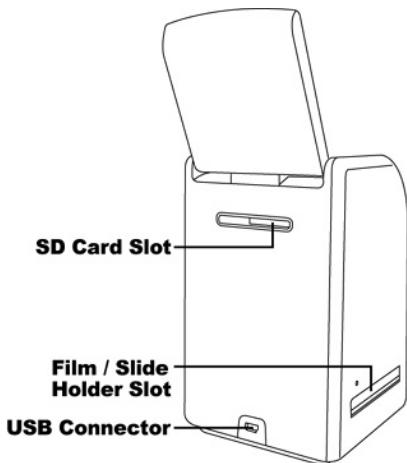
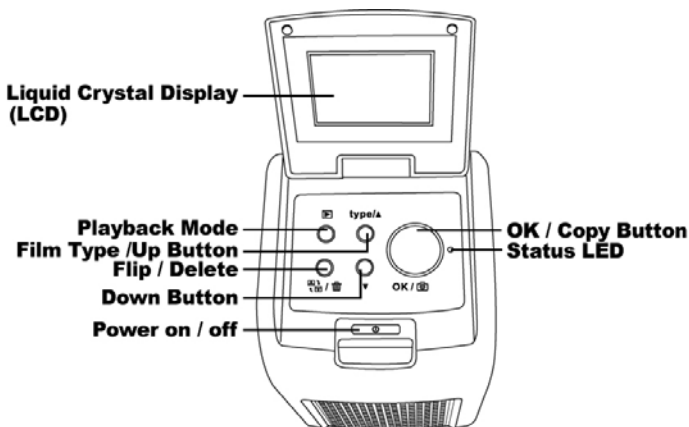

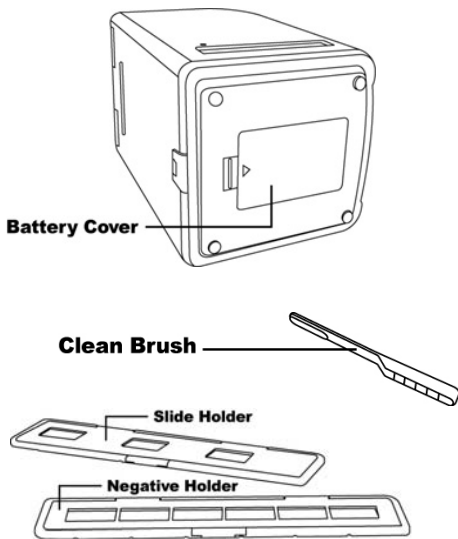

Note: We suggest using bundled brush to insert into the reflecta x4-Scan slot and clean the glass surface periodically to produce a clear image. Please make sure your film negatives/ mounted slides and cover trays are clean before inserting into the reflecta x4-Scan as well. Dust or dirt from the negatives and cover trays will affect the quality of your scanned images.

Installing the Battery Pack

1. Open the battery compartment cover by lightly pressing and sliding it back as shown.
2. Insert the supplied battery. Make sure the battery label is facing upwards and the (+ and -) ends of the battery match to the polarities indicated in the battery compartment.
3. Snap the cover back into place.

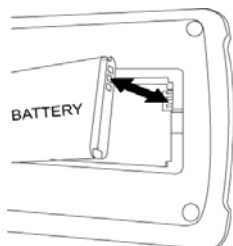
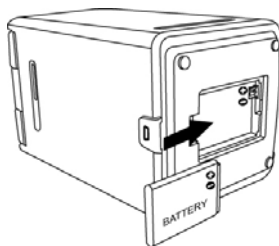

Battery power status



Charging the Battery Pack

The battery pack is not charged at the time of purchase and therefore needs to be charged before use. If the battery charge becomes low while you are using the copier, it is recommended to recharge it as soon as possible.

1. Insert the battery pack into the battery compartment (see page 8)
2. You may charge the battery in 2 ways:
 - (a) Plug the USB mini B of the supplied USB cable to the USB port of the copier, and plug the other USB end into the USB port of your computer/notebook. Please charge the battery at least 5.5~6 hours prior to your first use.

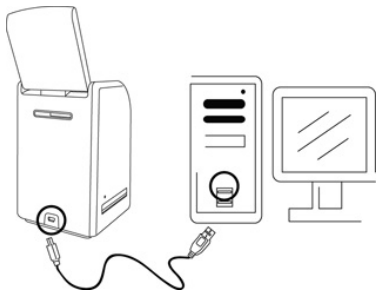

- (b) Plug the USB mini B of the supplied AC adaptor (optional) to the USB port of the copier, and plug the adaptor to the power outlet.
Please charge the battery at least 2.5~3 hours

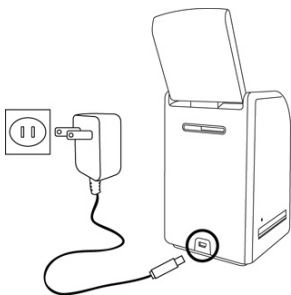

3. Red LED will light on during charging. When the battery pack is fully charged, the red LED light will be off and you may disconnect the charging connections.

Status LED:

Red: The Image Copier is OFF, the battery is charging.

Purple: The Image Copier is ON, the battery is charged simultaneously.

Blue: The Image Copier is ON, the battery is not charged or no battery is loaded.

3. Place Film/ Slide Into The Holder

1. Keep the glossy surface in the upward direction.
Open the negative/ positive slide holder as Illustrated.



2. Put a negative film/ positive slide into holder as shown.



3. Close the holder and please make sure the holder close properly.



4. Using the reflecta x4-Scan

1. Insert SD card into the SD card slot first.

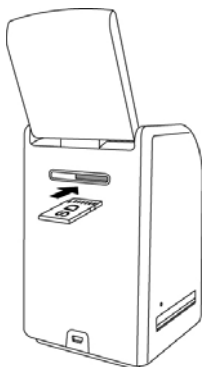

2. Press Power button to power on.
Press Power button to power off if you do not want to use the Image Copier.



3. Insert the loaded film/ slide holder properly into the slot according to the ▲ or ● sign shown on the Image Copier and film holder.

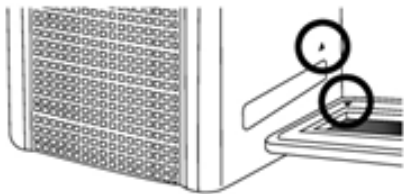

(Insert through front entrance)

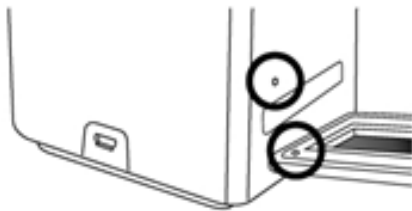

(Insert through rear entrance)

You can adjust the location of the film by moving the film holder; the film holder can be moved in both directions.

Keep your picture in the rectangular white frame, improper adjustment of picture may copy the black edges of the film holder.

If the black edge of a slide film is on top or bottom of the LCD display, tilt the copier forward or backward will eliminate the black edge.

You may crop away the black edges later by the software. (please refer to page 23 edit the pictures section 1.4 crop)

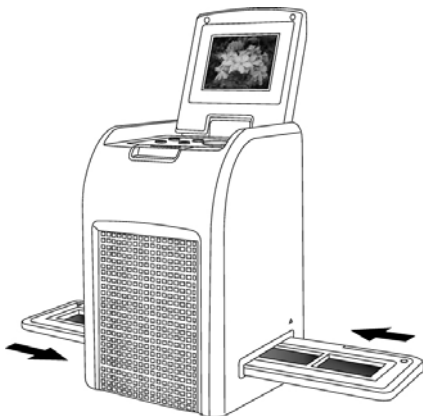

4. To select film type on the screen.
Press Film Type button for selection.

135 positive (slide)



135 negative



135 black & white

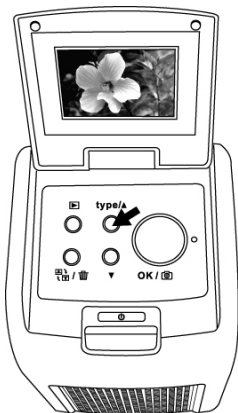

Note: Improper selection of Film type may not get good result.

5. Press Copy button to convert picture to Digitize image.
To get the best Digitize image wait for the image display on the LCD screen to adjust the brightness until it becomes stable. It normally take 3~4 seconds, depending on the brightness of your film.

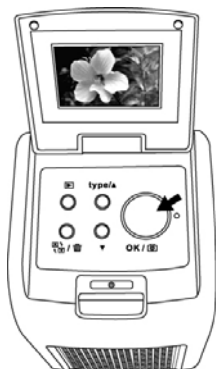

Note: For power saving the copier will automatically turns to sleep condition if you are not using it for more than 3 minutes. You may wake up the copier by pressing any one of the button.
If the copier is not using for more than 6 minutes it will turn off automatically.

6. Moving the film holder for next.



7. Press Flip button  to reverse image to 180 degrees. In case the slide is accidentally loaded into the film holder in an up side down direction.

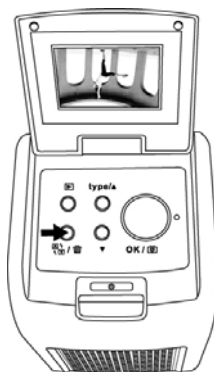

5. Playback Mode

1. Press Playback button for playback Digitize image.

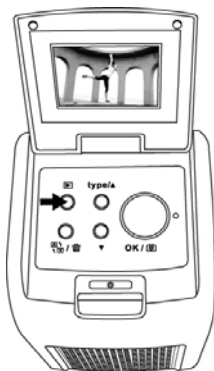

2. Press UP button to forward reviewing.
Press DOWN button for backward reviewing.

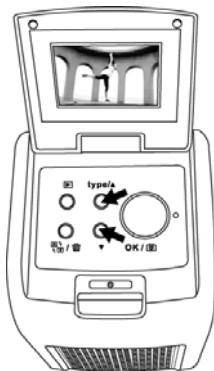

6. Delete Mode

1. Under Playback Mode

Press Delete button once to delete current image.



2. Press Delete button twice to delete all images.

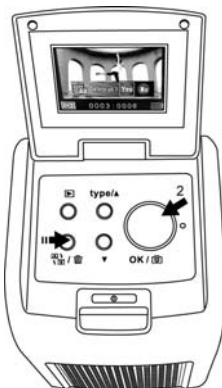

3. Press Delete button three times to format SD card.



Note: Formatting SD card will delete all the files in the card. Download your files in the SD card into your computer before the SD card is formatted.

7. To Link the Card to Computer

1. Plug the USB cable to copier and computer properly.



2. Turn power on.
3. Press the Up button to select "SD to PC" to **YES**, then press the OK button for confirmation.

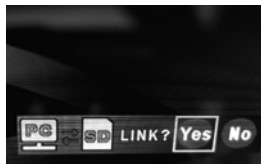
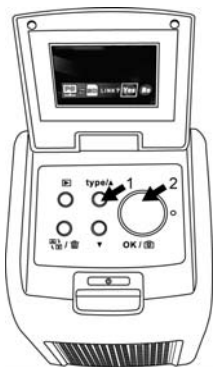

4. To active bundled software-MediaImpression, the images saved in SD card will be import to you computer automatically for reviewing.
Please copy the images from SD card to the designated folder or album of your computer.

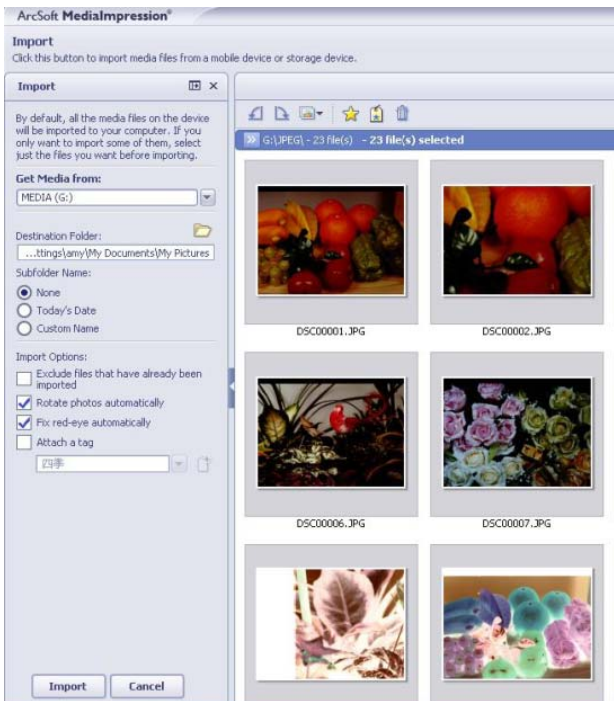

Note:

Bundled MediaImpression is only for images editing purpose.

The Acquire function is for Film Scanner/ Photo Scanner without TFT display.



8. Edit The Pictures

First, click on the picture to select, and then use the ArcSoft MediaImpression tools to edit the pictures as you like.

Edit

Photo Editing Tools

The Photo Editing Tools module includes a complete set of photo enhancement, editing and retouching controls. The windows can be stretched to provide a large size view of the active photo. Double click the module's tool bar to maximize the window to fill the computer screen. In addition to the large photo workspace, the Photo Editing Tools module includes five distinct sets of controls:

1. Adjust

1.1 Enhance

The Enhance feature includes two types of controls:

- Auto Enhance



Click the "Auto Enhance" button to improve the overall quality of your pictures with a single click.

- Manual Fix

For precise image enhancement control, adjust the brightness, contrast and sharpen sliders.

How to enhance a photo manually:

1. Move the sliders to adjust the level of brightness, contrast, saturation, hue and sharpen for adjustment.
2. Use the zoom slider to get a closer look at how the adjustment affects the photo.
3. Click "Apply" if you like the result. Click "Cancel" if you do not.

1.2 Color

This feature is designed to fix Digitize photos that have unnatural color or appear too dark. It's also great for fixing scanned versions of old prints that have faded or whose colors have changed after many years.

How to fix the color of a photo:

1. Drag the color balance sliders to make the photo color appear more natural. Add red or yellow to make the photo warmer. Add blue or green to make the photo cooler.
2. Drag the Lighter/Darker slider to the left to reveal details hidden in a dark photo or to the right to make a faded photo look new again.
3. Click "Apply" if you like the result. Click "Cancel" if you do not.

1.3 Red-Eye

This feature makes it easy for you to fix a red-eye – a common problem in flash photography.

There are two ways to fix red-eye:

- Auto Fix 

1. Simply click the "Fix Red-Eye" button to automatically find the fix all red-eye.
2. If not all of the red eye is fixed, use the "Click to Fix" method.

- Manual Fix

1. Use the zoom slider on the toolbar to zoom in on the photo.

2. Drag the small white box inside the zoom navigator to move over a red eye.
3. Place your cursor directly over the red eye and click.
4. Repeat the process until all the red eyes are fixed.
5. Click “Undo” if you make a mistake or don’t like the result.

1.4 Crop

This feature enables you to trim photos for a dramatic effect or cut off the distracting parts of a picture.

How to use the crop function:

1. Choose the crop orientation (portrait or landscape).
2. Select a fixed proportion for the crop rectangle (4:6, 5:7, 8:10) or choose “Custom” if you want to use a different proportion.
3. Resize the crop rectangle by clicking and dragging the red lines.
4. Move the crop rectangle into position by clicking and dragging inside the red box.
5. Click “Crop”. The area inside the rectangle will be kept, the area outside will be trimmed away.
6. Click “Undo” if you make a mistake or don’t like the result.

1.5 Straighten

This feature enables you to fix photos that appear to be tilted.

How to use Straighten:

1. Move the slider (or click the rotate buttons) until the photo appears straight.
2. Use the superimposed grid lines for vertical and horizontal reference.
3. Click “Apply” if you like the result. Click “Cancel” if you do not.

1.6 Blur Background

This feature can be used in subtle way – to tone down un-important background details, or for dramatic effect- by making the main subject of a photo “pop out” of the picture.

How to use the Blur Background function:

1. With your cursor, trace a line around the person or object you want to stand out. When you release the mouse button, the area outside the traced line will become slightly blurred.
2. Drag the first slider to make the transition between the blurred and non-blurred area sharp or smooth.
3. Drag the second slider to increase or decrease the amount of blur.
4. Click “Apply” if you like the result. Click “Cancel” if you do not.

Saving Your Results

When you’re done editing a photo, click “Save as” to save your results. You can choose to overwrite the original file or save a new one.

Click “Close” to exit the Photo Editing Module.

2. Retouch

2.1 Healing Brush



The Healing Brush is good for fixing dust, scratches and removing skin blemishes.

How to use the Healing Brush to fix a skin blemish:

1. Establish a source point for the Healing Brush by holding the Shift key and clicking on an area of the skin that is close in color and texture to the area you want to heal.
2. Use the zoom control to zoom in on the blemish.
3. Adjust the size of the healing brush so the cursor (circle) is only slightly larger than the blemish.
4. Paint over the blemish. The area will be concealed.
5. Click “Undo” if you make a mistake or don’t like the result.



2.2 Clone

The Clone tool is good for the removing unwanted elements from a photo. It can also be used for a fun effect, like moving a nose from one person t another.

How to use the Clone tool to remove a telephone pole from the background of a photo:

1. Establish a source point for the Clone tool by holding the Shift key and clicking on an area of the sky that you want to use to paint over the telephone pole.
2. Adjust the brush size so the cursor (circle) is only slightly larger than the widest part of the telephone pole.

3. Click and hold your mouse button and carefully paint over the telephone pole. Do not release the mouse button until the job is done. The sky will be cloned into place.
4. Click “Undo” if you make a mistake or don’t like the result.

2.3 Lighten/Darken



The Light/Darken tool is good for adjusting specific areas of a photo.

2.4 Smudge



Simulate the smearing of wet paint. Please click and drag the sliders below to change the brush size and sharpness.

2.5 Sharpen



Sharpen blurry areas. Click and drag the sliders below to change the brush size and transparency.

2.6 Blur



Smooth out rough areas. Click and drag the sliders below to change the brush size and intensity.

2.7 Paint Brush



Allows you to “paint” on your image when you click and drag the mouse. Click and drag the sliders below to change the brush size and transparency.

2.8 Line



Draw a straight line in the photo. Click and drag the sliders below to change the line width and transparency.

2.9 Eraser



Simulate an eraser, removing the image painting by paintbrush and line tools from your photo. Click and drag the sliders below to change the eraser size and effect.

3. Clipboard





















Clip the pictures by selecting Rectangular, Elliptical, Freehand, Magic wand and Magnetic.

Note: For more detailed information, please refer to the [Help section] of program.

9. Appendix

Specifications	
Image Sensor	1/2.5" inch 5 mega CMOS sensor,5.17Mega pixels
Preview and review	2.4" color LCD display
Lens Specification	F=6.4, f=12.36mm 2G2P
Color Balance	Automatic
Exposure Control	Automatic
Support film size auto cropping	135 film (36mm x 24mm)
Support film type auto converting	Slide Color Negative Film Black & White Negative Film
Focus Range	Fixed focus
PC interface	USB 2.0
Image Format	135 Film 3:2 ratio
Light Source	3 white LED
Power	From USB port, Li-ion 3.7V / 800mAh battery,
Dimension	16.5(H) X10 (W) X9.6 (L) cm
Bundled Software	ArcSoft MediaImpression
Specifications are subject to change without prior notice.	

Icons & Indicators

	Battery Full		Delete One
	Battery 2/3		Delete All
	Battery 1/3		Format SD card
	Battery Empty		Yes
	Slide		No
	Color Film		Card Error
	B/W Film		Card Full
	Available number take in SD card		Card Lock
	Playback Mode		PC-SDcard selection
	Wait		PC-SDcard Link

PC System Requirements

- Pentium[®] P4 1.2G processor
- Free USB2.0 port
- 512MB RAM internal memory minimum
- 500MB free hard disk space
- 800 x 600 pixel color monitor
- CD-ROM drive
- Windows[®] XP Service Pack II / Vista[™], 32/64 bits

Mac System Requirements

- PowerPC G4 800 MHz or Intel processor
- Free USB2.0 port
- 512MB RAM internal memory minimum
- 500MB free hard disk space
- 800 x 600 color monitor
- CD-ROM drive
- Mac 10.4.3 up

This symbol on the product or in the instructions means that your electrical and electronic equipment should be disposed at the end of its life separately from your household waste. There are separate collection systems for recycling in the EU. For more information, please contact the local authority or your retailer where you purchased the product.

