

A21C - 6U VMEbus QorIQ™ P1013/P1022 CPU (PMC/XMC)

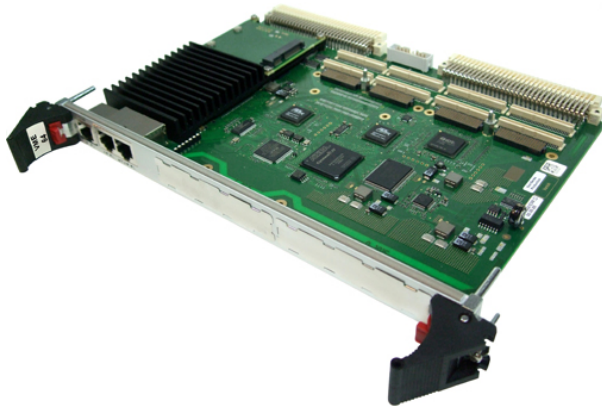

- Freescale™ PowerPC® QorIQ™ P1013, 800 MHz
- Up to dual-core P1022, 1.067 GHz
- 64-bit VMEbus master and slave
- Up to 2 GB DDR3 DRAM soldered, ECC
- Up to 64 MB Flash and 128 KB FRAM
- microSD™ card and mSATA slot
- 2 Gb Ethernet, 1 COM, additional I/O options
- 2 PMC/XMC slots
- U-Boot Universal Boot Loader
- -40 to +85°C screened

The A21C is a Freescale™ QorIQ™ based single-board computer for embedded industrial applications. The SBC features full VME64 support and can be used as a master or a slave in a VMEbus environment. The A21C provides 1 MB local dual-ported SRAM for slave access and communication between the local CPU and another VMEbus master.

The CPU card comes with a single-core P1013 or dual-core P1022 QorIQ™ processor with up to 1.067 GHz clock frequency and a serial communication architecture. With two Gigabit Ethernet ports and one RS232 COM at the front, and DDR3 SDRAM with ECC, Flash and FRAM, the board offers the crucial basics of an industrial computer. To satisfy your needs for mass storage, you can use microSD™ cards and mSATA plug-in modules.

In addition, the A21C can be equipped with up to two XMC or PMC mezzanine cards on shared sites, providing both front I/O (XMC/PMC) and rear I/O (PMC) for functions such as graphics, mass storage, or further Ethernet. The two PMC slots support modules up to 64-bit/133-MHz PCI-X, while the XMC slots are powered by

two PCI Express® x1 links each. The modular combination of I/O functionality on a single-board computer allows to build up tailored control systems which appear as customized solutions based on standard components.

Its sister card, the A21B, offers three M-Module™ slots instead of XMC/PMC, which are ideal for process I/O requirements.

Where there's a need for even more or other I/O, the A21C also includes a custom mezzanine-card option that reduces the board by one PMC/XMC slot but provides interfaces like USB 2.0, COM or even custom I/O controlled by the onboard FPGA. The mezzanine card is always an entirely customized adapter PCB, including front I/O, and makes the A21C a semi-custom solution. The A21C supports operation in a -40°C to +85°C temperature range, and the board withstands shock and vibration.

The CPU board is supported by the U-Boot Universal Boot Loader, which can be used for bootstrapping operating systems, for hardware testing, or for debugging applications without running any operating system.

Technical Data

CPU

- Freescale™ QorIQ™ P1022 or P1013, dual or single core
 - 600 MHz, 800 MHz or 1.067 GHz
 - Two/one high-performance Power Architecture e500v2 cores
 - Double precision floating point support and signal processing engine (SPE) APU

Memory

- 32 KB L1 instruction cache and 32 KB L1 data cache per processor core
- 256 KB L2 cache with ECC
- Up to 2 GB SDRAM system memory
 - Soldered
 - DDR3 with ECC support
 - 333 MHz memory bus clock frequency (667 MT/s, 5.33 GB/s data rate)
- Up to 64 MB boot/program Flash
- 128 KB non-volatile FRAM
- Serial EEPROM 4 kbits for factory settings

Mass Storage

- microSD™ card slot
 - Directly accessible on the board
 - Connected to SDHC controller
- mSATA disk slot
 - Directly accessible on the board (via small adapter card)
 - Connected via one SATA channel

I/O

- Ethernet
 - Two 10/100/1000Base-T Ethernet channels at the front
 - RJ45 connectors at front panel
 - Two front LEDs for each port to signal LAN link and activity status
- One RS232 UART (COM1)
 - RJ45 connector at front panel
 - Data rates up to 230.4 kbit/s
 - 16-byte transmit/receive buffer
 - Handshake lines: CTS, RTS

Front Connections

- Two Ethernet (RJ45)
- One RS232 COM (RJ45)
- PMC / XMC front I/O if populated

Rear I/O

- PMC 0 and 1

Mezzanine Extensions

- Two slots usable for PMC or XMC
- XMC slots
 - Compliant with XMC standard VITA 42.3-2006
 - Two x1 PCI Express® links for slot 0, data rate 250 MB/s per link in each direction (2.5 Gbit/s per lane)
 - Two x1 PCI Express® links for slot 1, data rate 125 MB/s per link in each direction (1.25 Gbit/s per lane)
 - PCIe® 1.0a support (PCI Express® Base Specification)
- PMC slots
 - Compliant with PMC standard IEEE 1386.1
 - PCI / PCI-X 32/64 bits, 33/66/133 MHz, 3.3 V V(I/O)
 - PMC I/O module (PIM) support through J4 for both slots

Miscellaneous

- Real-time clock, buffered by a GoldCap or battery (optional)
- Watchdog
- Voltage monitor and temperature sensor
- Reset button and status LEDs at the front panel

VMEbus

- Compliant with VME64 Specification
- Slot-1 function with auto-detection
- Master
 - D08(EO):D16:D32:D64:A16:A24:A32:ADO:BLT:RMW
- Slave
 - D08(EO):D16:D32:D64:A16:A24:A32:BLT:RMW
- 1 MB shared fast SRAM
- DMA
- Mailbox functionality
- Interrupter D08(O):I(7-1):ROAK
- Interrupt handler D08(O):IH(7-1)
- Single level 3 fair requester
- Single level 3 arbiter
- Bus timer
- Location Monitor
- Performance
 - Coupled read/write D32 non-block transfer rate tbd. MB/s
 - DMA read/write D32 BLT transfer rate tbd. MB/s
 - DMA read/write D64 MBLT transfer rate tbd. MB/s

Electrical Specifications

- Supply voltage/power consumption:
 - +5 V (-3%/+5%), tbd. typ.
 - +3.3 V (-3%/+5%), tbd. typ.
 - ±12 V (-5%/+5%), only provided for mezzanines that need 12 V

Technical Data

Mechanical Specifications

- Dimensions: standard double Eurocard, 233.3 mm x 160 mm
- Weight (without mezzanines): 412 g

Environmental Specifications

- Temperature range (operation):
 - -40..+85°C (screened)
 - Airflow: min. 1.0 m/s
- Temperature range (storage): -40..+85°C
- Relative humidity (operation): max. 95% non-condensing
- Relative humidity (storage): max. 95% non-condensing
- Altitude: -300 m to +3000 m
- Shock: 50 m/s², 30 ms (EN 61373)
- Vibration (function): 1 m/s², 5 Hz - 150 Hz (EN 61373)
- Vibration (lifetime): 7.9 m/s², 5 Hz - 150 Hz (EN 61373)
- Conformal coating on request

MTBF

- 286 910 h @ 40°C according to IEC/TR 62380 (RDF 2000)

Safety

- PCB manufactured with a flammability rating of 94V-0 by UL recognized manufacturers

EMC Conformity

- EN 55022 (radio disturbance)
- IEC 61000-4-2 (ESD)
- IEC 61000-4-3 (electromagnetic field immunity)
- IEC 61000-4-4 (burst)
- IEC 61000-4-5 (surge)
- IEC 61000-4-6 (conducted disturbances)

BIOS

- U-Boot Universal Boot Loader

Software Support

- Linux (in preparation)
- VxWorks® (in preparation)
- OS-9® (in preparation)
- QNX® (on request)
- [For more information on supported operating system versions and drivers see Software.](#)

Diagram

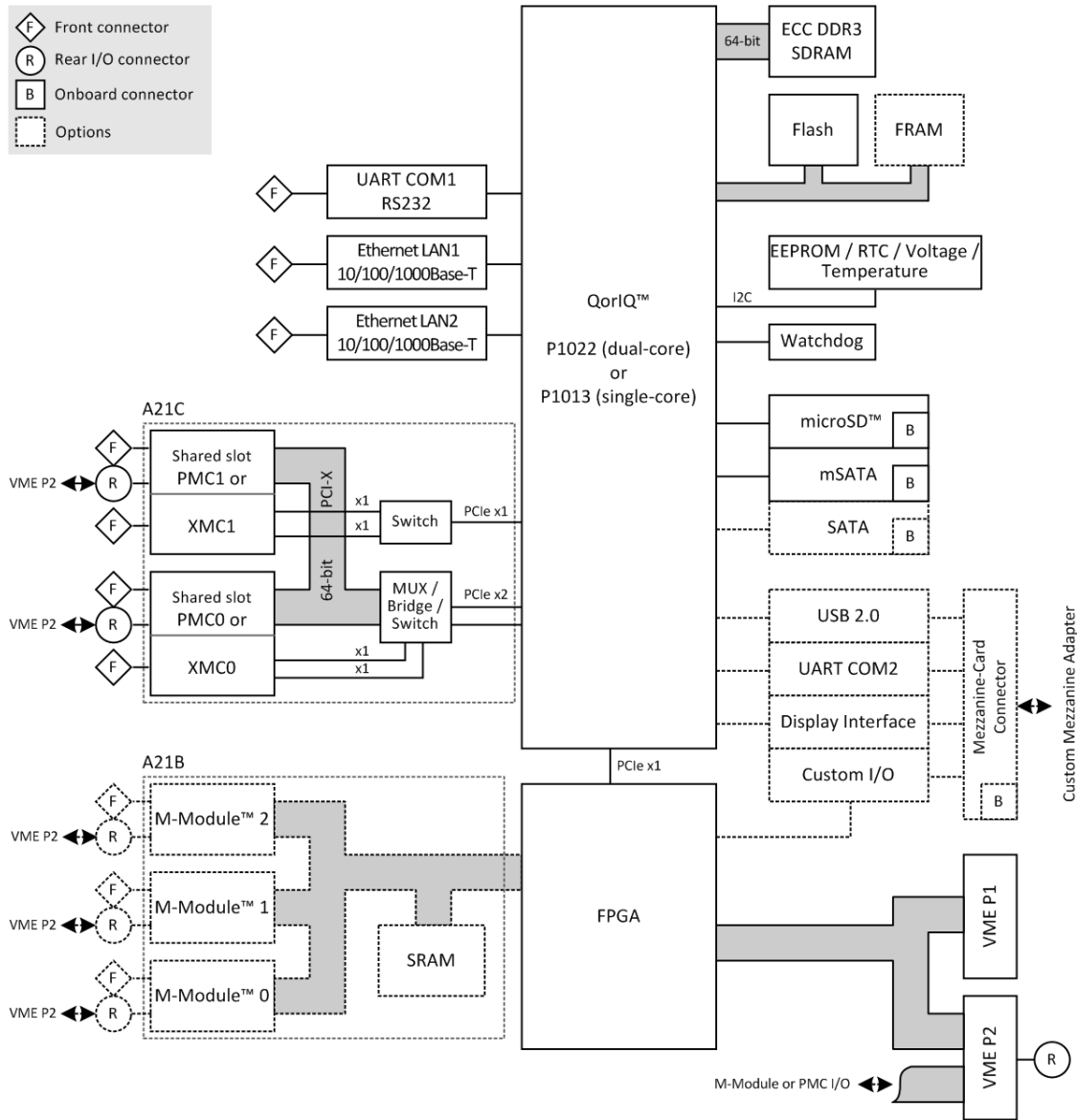

Configuration & Options

Standard Configurations

Article No.	CPU Type and Clock	System RAM	Flash	FRAM	SATA	Mezzanine Slots	Operating Temperature
01A021C00	P1013 single-core, 800 MHz	1 GB	32 MB	128 KB	Only mSATA	2 PMC/XMC	-40..+85°C
01A021B00	P1013 single-core, 800 MHz	1 GB	32 MB	128 KB	Only mSATA	3 M-Modules™	-40..+85°C

Options

CPU

- QorIQ™ P1022 or P1013
 - P1022: dual core
 - P1013: single core
- All processors available with 600 MHz, 800 MHz or 1.067 GHz

Memory

- System RAM
 - 1 GB or 2 GB
- Boot/program Flash
 - 32 MB or 64 MB
- FRAM
 - 0 KB or 128 KB

Mass Storage

- Serial ATA (SATA)
 - Onboard SATA connector for one additional port possible
 - SATA Revision 2.x support
 - Transfer rates up to 300 MB/s (3 Gbit/s)
 - For connection of an in-system hard-disk drive

I/O

- Various additional I/O possible using onboard mezzanine card
 - Partly fixed set of interfaces, plus 16 pins for custom I/O
 - One USB 2.0 port, EHCI implementation
 - Additional UART COM interface
 - Display interface
 - Custom I/O functions can be implemented as FPGA IP cores (16 pins usable)
 - Occupies the space of PMC/XMC slot 1
 - Please note that the mezzanine card is always completely customized, including front I/O, no standard cards are available.

Mezzanine Slots

- 3 M-Modules™ instead of PMC/XMC (A21B variety)

Miscellaneous

- Back-up battery holder for real-time clock (RTC) (may be in mechanical conflict with PMC/XMC slot 0)

Software Support

- QNX®

Please note that some of these options may only be available for large volumes. Please ask our sales staff for more information.

Ordering Information

Standard A21C Models

01A021C00 A21C, Freescale™ QorIQ™ single-core P1013, 800 MHz, 1 GB DDR3 ECC SDRAM, 32 MB Flash, 2 PMC/XMC slots, -40 to +85°C screened

Related Hardware

01A021B00 A21B, Freescale™ QorIQ™ single-core P1013, 800 MHz, 1 GB DDR3 ECC SDRAM, 32 MB Flash, 3 M-Module™ slots, -40 to +85°C screened

Memory

0751-0046 MicroSD card, 2 GB, -40..+85°C

0751-0051 SSD mSATA, 8 GB, -40..+85°C

0751-0052 MicroSD card, 4 GB, -40..+85°C

Miscellaneous Accessories

05F006-00 RS232 interface cable RJ45 to 9-pin D-Sub (1 COM to 1 COM), 2m

05P000-01 25 mounting screw sets to fix PMC/XMC modules on carrier boards

Software: Firmware/BIOS

This product uses the U-Boot bootloader available from DENX together with board-specific additions from MEN.

14A021-00 U-Boot Bootloader (DENX/MEN) for A21B and A21C

For operating systems not mentioned here contact MEN sales.

Documentation

Compare Chart 6U VMEbus CPU and I/O cards Download

20A021-00 A21B/A21C User Manual

For the most up-to-date ordering information and direct links to other data sheets and downloads, see the A21C online data sheet under » www.men.de.

Contact Information

Germany

MEN Mikro Elektronik GmbH
 Neuwieder Straße 3-7
 90411 Nuremberg
 Phone +49-911-99 33 5-0
 Fax +49-911-99 33 5-901
 E-mail info@men.de
www.men.de

France

MEN Mikro Elektronik SA
 18, rue René Cassin
 ZA de la Châtelaïne
 74240 Gaillard
 Phone +33 (0) 450-955-312
 Fax +33 (0) 450-955-211
 E-mail info@men-france.fr
www.men-france.fr

USA

MEN Micro, Inc.
 24 North Main Street
 Ambler, PA 19002
 Phone (215) 542-9575
 Fax (215) 542-9577
 E-mail sales@menmicro.com
www.menmicro.com

The date of issue stated in this data sheet refers to the Technical Data only. Changes in ordering information given herein do not affect the date of issue.

All brand or product names are trademarks or registered trademarks of their respective holders.

MEN is not responsible for the results of any actions taken on the basis of information in the publication, nor for any error in or omission from the publication.

MEN expressly disclaims all and any liability and responsibility to any person, whether a reader of the publication or not, in respect of anything, and of the consequences of anything, done or omitted to be done by any such person in reliance, whether wholly or partially, on the whole or any part of the contents of the publication.

The correct function of MEN products in mission-critical and life-critical applications is limited to the environmental specification given for each product in the technical user manual. The correct function of MEN products under extended environmental conditions is limited to the individual requirement specification and subsequent validation documents for each product for the applicable use case and has to be agreed upon in writing by MEN and the customer. Should the customer purchase or use MEN products for any unintended or unauthorized application, the customer shall indemnify and hold MEN and its officers, employees, subsidiaries, affiliates, and distributors harmless against all claims, costs, damages, and expenses, and reasonable attorney fees arising out of, directly or indirectly, any claim or personal injury or death associated with such unintended or unauthorized use, even if such claim alleges that MEN was negligent regarding the design or manufacture of the part.

In no case is MEN liable for the correct function of the technical installation where MEN products are a part of.

Copyright © 2012 MEN Mikro Elektronik GmbH. All rights reserved.

