

S100EM Metal Password Access Controller
User Manual



Reading carefully before install and use this manual

1. Product Profile

The product is Contact-less inductive card Metal Password Access Controller, According to the model, respectively support EM, HID, MIFARE three cards. It is one of the most advanced stand alone access controller. It uses unique metal exterior design, Dexterity keyboard panel operation, Built-in high-grade microprocessors, Strong anti-interference ability, Safety and reliability is extremely high, can provide a powerful security for 2,000 users. It has strong functions, such as low power consumption, Luminous keyboard, independent passwords, wiegand output, the output short circuit protection, door magnetic alarm, prevent demolition alarm, exit button, the doorbell interface, level of security Settings, etc. widely used in home, office, residential area and other public places.

2. Features

Low power consumption: less than 30mA standby current

Luminous keyboard: the night can also operate keyboard

User capacity: support 2,000 users

Independent password: can use password which irrelevant with the card to open the door

User modification password: Users can revise the door password

Search speed: charge to open the door time less than 0.1 S.

Output short circuit protection: electric lock or alarm output circuit within 100 μ S when shut down automatically output

Wiegand output: With Wiegand output interface, Wg26 card number or Wg4 buttons output

Usable keyboard delete card number: After card is lost, usable keyboard delete card, Thoroughly eliminate safety lapses

The demolition alarm: Illegal dismantling machine, built-in alarm sound buzzer

The bell button and interface: key and circuit segregation, external any the doorbell.

3. Technical parameters

Work Voltage: AC&DC9-28V

Static Current: $\leq 30\text{mA}$
Reading Range: 3~8cm
Capacity: 2000 users
Ambient Temperature: $-25^{\circ}\text{C} \sim 60^{\circ}\text{C}$
Ambient Humidity: 10%~90%
Electricity lock output: $\leq 3\text{A}$
Alarm output: $\leq 20\text{A}$
Output short circuit protection time: $\leq 100\mu\text{S}$
Open time: 0 ~ 99 seconds (adjustable)
Size: 120 *80*25mm

4. Administrator operation

Restore factory settings:

Disconnect the power supply open the back cover, use the equipped two feet short-circuit the inserting pin, plugged into the machine rear Two short circuit seat, then electrify, The machine "di di" two empress, then take short circuit, namely the inserting pin for initialization of success. (Figure 1)

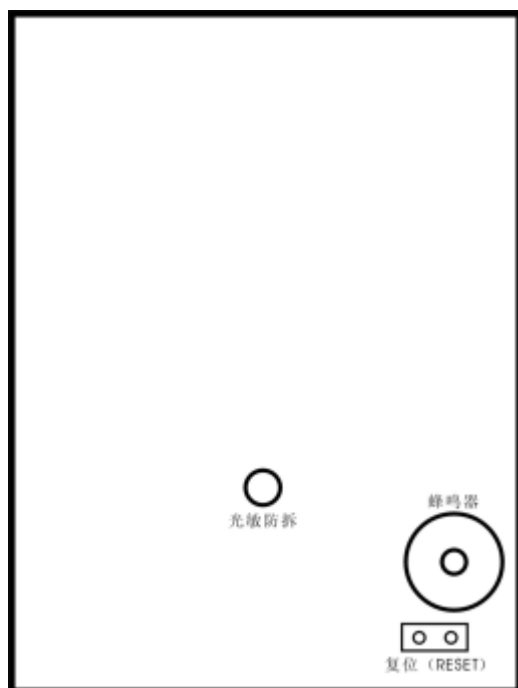

Figure 1

Note: restore factory Settings will not delete a user data

Enter administrator operation status:

Press Administrator the default password: 999999

4.1 Modify administrator password:

Press

Note: the administrator password for 6 ~ 8 random Numbers, please take good care.

4.2 Add user:

4.2.1 Continuous increase card:

Press , , ...

4.2.2 Designated card No increase:

Press , , ...

Automatically increase, the user ID automatically generated by this machine, the range is 1 ~ 2000, and search from small to large.

4.2.3 Designated ID No swipe card increase:

Press , , ...

4.2.4 Designated ID No and card No increase:

Press , , ...

Note: input ID digits for 1-4 digits, The range is 1 ~ 2000, such as 1,01,001,0001 ID number all expressed 1.

Add card user will automatically generate a default password "1234", but this password can't open the door, only for a user to change a new password.

4.2.5 Designated ID No and password increase:

Press ...

Note: applicable to no card users, password and card unrelated, input digits for four, but not for "1234"

4.3 Delete user

4.3.1 Delete swipe card

Press ...

4.3.2 Delete Designated card Number:

Press , , ...

4.3.3 Delete Designated ID Number:

Press ...

4.3.4 Delete all:

Press

4.4 Door open method setting:

4.4.1 Card open:

Press

4.4.2 Card + Password open:

Press

4.4.3 Card or Password open: (Factory default)

Press

4.5 Unlock time setting:

Press



Note: The lock time range "0 to 99 seconds ", the factory default is 5 seconds

4.6 Alarm time setting:

Press

Note: The alarm time range "0 to 3 minutes ", the factory default is 1 minute

4.7 Magnetic Alarm Function setting:

4.7.1 Shielding of the function (factory default):

Press .

4.7.2 Open the function:

Press .

Open the function, two possibilities:

4.7.2.1 If you open the door not closed properly, 1 minute, built-in buzzer alarm tone hair tips, door or turn off automatically after 1 minute.

4.7.2.2 If normal unlock 20 seconds after the doors open, or door is forced open, external alarm and built-in buzzer alarm at the same time

4.8 Security mode setting

4.8.1 Normal mode (factory default)

Press .

4.8.2 Lock mode:

Press .

That within ten minutes of continuous brush invalid card or enter the wrong password ten times, external alarm and built-in buzzer alarm at the same time

5. User operations

5.1 User use card modify password:

Press

5.2 User use ID No modify password

Press

Note: applicable to a card or without card users, if the user password is "1234", must use card to modify

5.3 Card open:

, Effective namely open

5.4 Password open:

Press , Password right namely open

5.5 Card + Password open:

, Card and password right namely open

6 Remove alarm operation

6.1 External alarm and built-in buzzer alarm at the same time

Swipe or press , Can remove alarm.

6.2 Close door alarm tips

Close the door, or swipe card , or , Can remove alarm

7. Acousto-optic instructions

Operation state	Red Light	Green Light	Buzzer	Note
Standby	Slow flashing	Off		
Buttons			Di	
Success	Off	On	Di—	
Failure			DiDiDi	
Into programming	On	Off	Di—	Indicator is orange
Set condition	On	On		
Exit programming	Slow flash	Off	Di—	
Unlock	Off	On	Di—	
Alarm	Fast flashing	Off	Alarm sound	

8 Installation method, lead wire description and Cabling diagram

8.1 Installation method

8.1.1 On the wall of the aperture size machine on the pan is playing well with a hole, or installed 2 existing junction box plus connecting.(Figure 2)

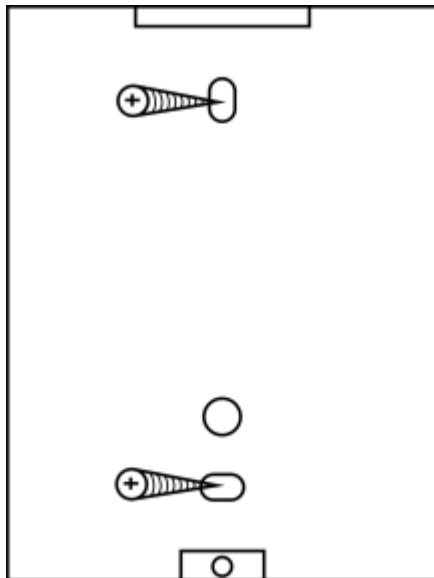

Figure 2

8.1.2 Put the lead wire from Bottom shell of the outlet hole out, he connection of cable needed, Unused lines wrapped with insulating tape isolated to prevent short circuit

8.1.3 Finish line, Install the front cover to the back cover, Finally tighten the screws, Fixed the front cover and back cover.

8.2 Lead wire description

Line sequence	Marks	Color	Function description
1	BELL_A	Pink	Doorbell button one end
2	BELL_B	Pale blue	The doorbell button to the other end
3	D0	Green	WG output line D0
4	D1	White	WG output line D1
5	ALARM	Grey	Alarm negative (alarm positive connected + 12 v)
6	OPEN	Yellow	Exit button one end (Exit button the other end connected GND)
7	D_IN	Brown	Magnetic switch one end (magnetic switch another end connected GND)
8	AC&DC	Red	Power supply 9-28V input (DC input+)
9	AC&DC	Black	Power supply 9-28V input (DC input -)
10	NO	Blue	Relay normally-on end (Connected positive electric lock +)
11	COM	Purple	Relay Public end , Connected GND
12	NC	Orange	Relay Closed end (connected negative electric lock +)
13	GND	Shielding layer	Ac input for machines minus

8.3 Cabling diagram

8. 3. 1 Ordinary power supply Cabling diagram

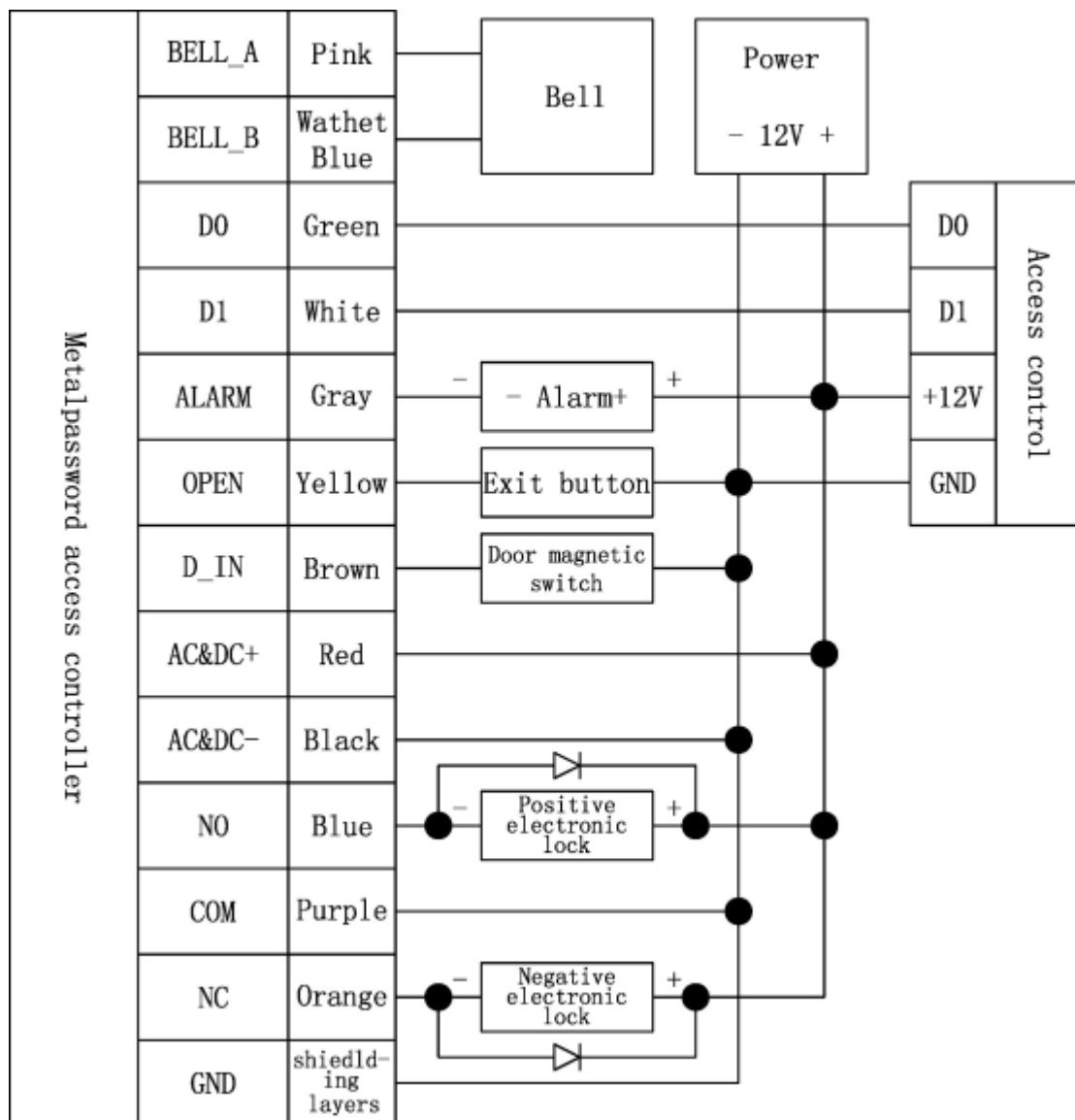

Figure 3 Ordinary power supply Cabling diagram

8. 3. 2 Access Control Power Supply Cabling diagram

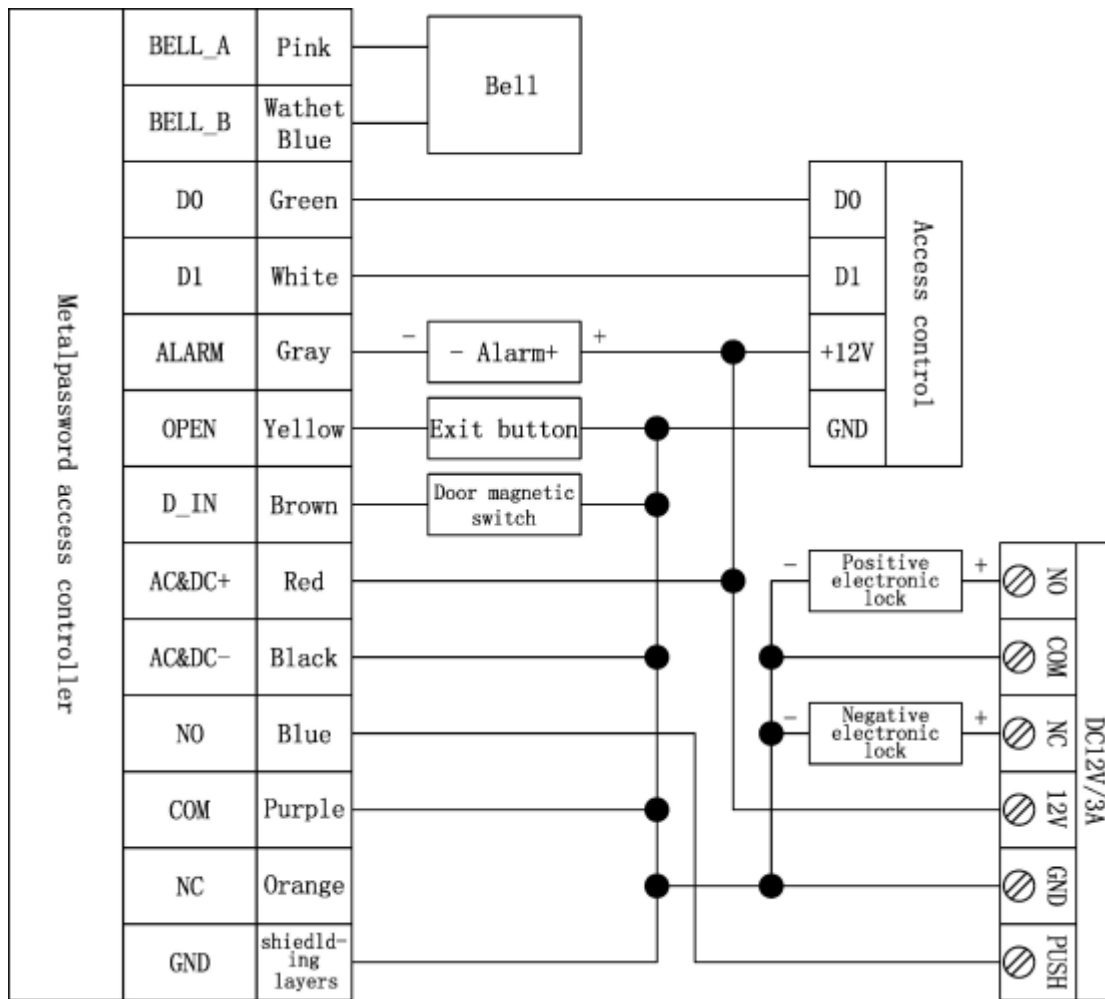

Figure 4 Access Control Power Supply Cabling diagram

9 Packing list

Name	Model/specification	Quantity	Note
Metal Password access controller	S100EM	1	
User manual	S100EM	1	
Tapping screws	Φ4mm×28 mm	4	Used for installation fixed
Stopper	Φ6mm×30 mm	4	Used for installation fixed
Star screwdriver	Φ20mm×60mm	1	Secial
Star screws	Φ3mm×6mm	1	Used between

			the front cover and back cover for a fixed
LED	1N4007	1	

Warm Tip:

- * Please don't secretly repair machine, if any problem, please return to factory maintenance.
- * Before the installation on the wall, if you want to punch, please check carefully wiring or line tube, prevent drilling broken wiring etc unnecessary trouble, please use safe glasses when drilling or fixed line clip.
- * If product upgrades, specifications will likely differ, without prior notice.