

Owner's Guide 0300191-04 Rev. A

CONTROLLOGIX™

UNIVERSAL ANALOG INPUT MODULE

Catalog Number: 1756sc-IF8u



 **SPECTRUM**
CONTROLS

Important Notes

1. Please read all the information in this owner's guide before installing the product.
2. The information in this owner's guide applies to hardware version A and firmware version 2.0 or later.
3. This guide assumes that the reader has a full working knowledge of the relevant processor.

Notice

The products and services described in this owner's guide are useful in a wide variety of applications. Therefore, the user and others responsible for applying the products and services described herein are responsible for determining their acceptability for each application. While efforts have been made to provide accurate information within this owner's guide, Spectrum Controls assumes no responsibility for the accuracy, completeness, or usefulness of the information herein.

Under no circumstances will Spectrum Controls be responsible or liable for any damages or losses, including indirect or consequential damages or losses, arising out of either the use of any information within this owner's guide or the use of any product or service referenced herein.

No patent liability is assumed by Spectrum Controls with respect to the use of any of the information, products, circuits, programming, or services referenced herein.

The information in this owner's guide is subject to change without notice.

Limited Warranty

Spectrum Controls warrants that its products are free from defects in material and workmanship under normal use and service, as described in Spectrum Controls literature covering this product, for a period of 1 year. The obligations of Spectrum Controls under this warranty are limited to replacing or repairing, at its option, at its factory or facility, any product which shall, in the applicable period after shipment, be returned to the Spectrum Controls facility, transportation charges prepaid, and which after examination is determined, to the satisfaction of Spectrum Controls, to be thus defective.

This warranty shall not apply to any such equipment which shall have been repaired or altered except by Spectrum Controls or which shall have been subject to misuse, neglect, or accident. In no case shall the liability of Spectrum Controls exceed the purchase price. The aforementioned provisions do not extend the original warranty period of any product which has either been repaired or replaced by Spectrum Controls.

Preface

Read this preface to familiarize yourself with the rest of the owner's guide. This preface covers:

- who should use this guide
- what this guide covers
- related Allen-Bradley documents
- terms & abbreviations you should know

Who Should Use This Guide

Use this guide if you design, install, program, or maintain a control system that uses Allen-Bradley ControlLogix Controllers.

You should have a basic understanding of ControlLogix products. You should also understand electronic process control and the ladder program instructions required to generate the electronic signals that control your application. If you do not, contact your local Allen-Bradley representative for the proper training before using these products.

What This Guide Covers

This guide covers the 1756sc-IF8u universal analog input module. It contains the information you need to install, wire, use, and maintain these modules. It also provides diagnostic and troubleshooting help should the need arise.

Related Allen-Bradley Documents

Table A lists several Allen-Bradley documents that may help you as you use these products.

Table A. Related Allen-Bradley documents

Allen-Bradley Doc. No.	Title	Publication Number
1756-PA72, -PB72	ControlLogix Power Supply Installation Instructions	1756-5.1
1756-A4, -A7, -A10, -A13, -A17	ControlLogix Chassis Installation Instructions	1756-5.2

1756 Series ControlLogix Module Installation Instructions (Each module has separate document for installation)	1756-5.5, -5.42
1756-L1, Logix5550 Controller User Manual -L1M1, -L1M2	1756-6.5.12
1756-DHRIO ControlLogix Data Highway Plus Communication Interface Module User Manual	1756-6.5.2
1756-ENET ControlLogix Ethernet Communication Interface Module User Manual	1756-6.5.1

To obtain a copy of any of the Allen-Bradley documents listed, contact your local Allen-Bradley office or distributor.

Terms & Abbreviations You Should Know

You should understand the following terms and abbreviations before using this guide.

A/D - Refers to analog-to-digital conversion. The conversion produces a digital value whose magnitude is proportional to the instantaneous magnitude of an analog input signal.

Attenuation – The reduction in magnitude of a signal as it passes through a system. The opposite of gain.

Channel – Refers to one of eight, small-signal analog input interfaces to the module's terminal block. Each channel is configured for connection to an input device, and has its own configuration and status words.

Chassis – See rack.

CJC - (Cold Junction Compensation) The means by which the module compensates for the offset voltage error introduced by the temperature at the junction between the thermocouple lead wire and the input terminal block (the cold junction).

Common mode rejection ratio (CMRR) - The ratio of a device's differential voltage gain to common mode voltage gain. Expressed in dB, CMRR is a comparative measure of a device's ability to reject interference caused by a voltage common to its terminal relative to ground.

Common mode voltage – The voltage difference between the negative terminal and analog common during normal differential operation.

Cut-off frequency - The frequency at which the input signal is attenuated 3 dB by the digital filter. Frequency components of the input signal that are below the cut-off frequency are passed with under 3 dB of attenuation for low-pass filters.

dB (decibel) – A logarithmic measure of the ratio of two signal levels.

Digital filter - A low-pass mathematic single order filter applied to the A/D signal. The digital filter provides high-frequency noise rejection.

Effective resolution – The number of bits in the channel data word that do not vary due to noise.

Local System - A control system with I/O chassis within several feet of the processor.

LSB (least significant bit) – The bit that represents the smallest value within a string of bits.

Multiplexer – A switching system that allows several input signals to share a common A/D converter.

Normal mode rejection (differential mode rejection) – A logarithmic measure, in dB, of a device's ability to reject noise signals between or among circuit signal conductors, but not between the equipment grounding conductor or signal reference structure and the signal conductors.

Module update time – See channel update time.

Remote system - A control system where the chassis can be located several thousand feet from the processor chassis. Chassis communication is via the 1756-DHRIO and 1756-ENET Adapter.

Resolution – The smallest detectable change in a measurement, typically expressed in engineering units (e.g. 0.15 °C) or as a number of bits. For example, a 12-bit system has 4096 possible output states. It can therefore measure 1 part in 4096. See also effective resolution.

RTD (Resistance Temperature Detector) - A temperature sensing element with 2, 3, 4, lead wires. It uses the basic characteristics that electrical resistance of metals increases with temperature. When a small current is applied to the RTD, it creates a voltage that varies with temperature. This voltage is processed and converted by the RTD module into a temperature value.

Sampling time - The time required by the A/D converter to sample an input channel.

Step response time – The time required for the A/D signal to reach 95% of its expected, final value, given a full-scale step change in the output data word.

Tags - Identifiers for configuration, data, and status information found within the module. Tags allow the user to modify specific module attributes and view data and status.

Update time – The time for the module to sample and convert a channel input signal and make the resulting value available to the ControlLogix processor.

Table of Contents

Preface	v	Who Should Use This Guide	v
		What This Guide Covers	v
		Related Allen-Bradley Documents	v
		Table A. Related Allen-Bradley documents	v
		Terms & Abbreviations You Should Know	vi
Module Overview	1	General Description	1
		Detailed Specifications	2
		Hardware Features	3
		Diagnostic LEDs	4
		System Overview	4
		System Operation	5
		Module Operation	5
		Compatibility with Thermocouple, Current, and Millivolt Devices & Cables	6
Installing And Wiring Your Module	9	Electrostatic Damage	9
		Power Requirements	10
		Table 2.1 Maximum current drawn by the module	10
		Module Installation and Removal	10
		Figure 2.1 Module insertion into a rack	13
		Figure 2.2 Terminal block diagram with keying	14
		Wiring Your Module	14
		Preparing and Wiring the Cables	15
		Terminal Block Layout	16
		Wiring Voltage/Current Inputs the IF8u Module	17
		Wiring RTD or Resistance Sensors to the IF8u Module	18
		Wiring Thermocouples to the IF8u Module	20
Operation Within the ControlLogix System	23	Ownership and Connections	23
		Using RSNetWorx and RSLogix 5000	23
		Direct Connections	24
		Module Operation	24
		Modules in a Local Chassis	25
		Requested Packet Interval (RPI)	25
		Modules in a Remote Chassis	26
		Listen-Only Mode	27
		Multiple Owners of Input Modules	27
		Configuration Changes in an Input Module with Multiple Owners	28
Programming Your Module	29	Module Installation	29
		Adding Your Module to a Project	29
		Configuring module attributes: Configuration Tags	34

Configuration, Data, and Status Tags 37

Send Configuration Data to the Module	37
Configuration Tags	38
Global Module Settings	38
Channel Specific Settings	43
Input Tags	50
Fault and Status Reporting Tags	50
Module Data Tags	53

Programming Examples 55

Initial Programming	55
Figure 5.1 Sample Ladder Logic	56

Troubleshooting 61

Using Module Indicators to Troubleshoot	61
Using RSLogix 5000 to Troubleshoot Your Module	62
Module Configuration Errors	64

Maintaining Your Module And Ensuring Safety 65

Preventive Maintenance	65
Safety Considerations	65

Module Specifications 69

Electrical Specifications	69
Physical Specifications	70
Environmental Specifications	70
Input Specifications	70

Thermocouple Descriptions 75

J Type Thermocouples	75
K Type Thermocouples	77
T Type Thermocouples	79
E Type Thermocouples	81
R Type Thermocouples	83
S Type Thermocouples	84
B Type Thermocouples	86
N Type Thermocouples	87
References	90

Using Grounded
Junction,
Ungrounded
Junction, and
Exposed Junction
Thermocouples 97

Thermocouple Types	97
Grounded Junction	98
Ungrounded (Insulated) Junction	98
Exposed Junction	98
Isolation	98

Programming Your
Module 101

Module Installation	101
Adding Your Module to a Project	101
Declaration of Conformity	105

Module Overview

This chapter describes the universal analog input module and explains how the ControlLogix controller reads analog input data from the module. Read this chapter to familiarize yourself further with your universal analog input module. This chapter covers:

- general description and hardware features
- an overview of system and module operation

General Description

This module is designed exclusively for use in the Allen-Bradley ControlLogix 1756 I/O rack systems. The module stores digitally converted thermocouple, RTD, resistance, millivolt (mV), volt (V), milliamp (mA), and CJC temperature analog data in its image table for retrieval by all ControlLogix processors.

Following is a list of features available on the IF8u module that allow their use in a wide variety of applications.

- Removal and insertion under power (RIUP) - a system feature that allows you to remove and insert modules while chassis power is applied
- Producer/consumer communications - an intelligent data exchange between modules and other system devices in which each module produces data without having been polled
- Rolling timestamp of data - 15 bit module-specific rolling timestamp with millisecond resolution which indicates when data was sampled/applied. This timestamp may be used to calculate the interval between channel or updates
- System timestamp of data - 64 bit system clock places a timestamp on the transfer of data between the module and its owner controller within the local chassis
- IEEE 32 bit floating point format
- On-Board Features, such as custom User Scaling, Process Alarms, Rate Alarms, Digital Filtering, and Under/Ovrerange Detection
- Automatic Calibration - analog I/O modules may perform autocalibration on a channel-by-channel or module-wide basis to reduce drift inaccuracies due to module ambient temperature changes.
- Class I/Division 2, UL, CSA, CE, and FM Agency Certification

Detailed Specifications

Input Ranges

The following tables provide compatibility information on the supported thermocouple types and their associated temperature ranges, the supported RTD types and their associated temperature ranges, as well as the millivolt, volt, milliamp and resistance input types supported by the IF8u module. To determine the practical temperature range of your thermocouple, refer to the specifications in appendices A and B.

Table 1.1 Thermocouple Temperature Ranges

Type	°C Temperature Range	°F Temperature Range
J	-210°C to 1200°C	-346°F to 2192°F
K	-270°C to 1372°C	-454°F to 2502°F
T	-270°C to 400°C	-454°F to 752°F
B	300°C to 1820°C	572°F to 3308°F
E	-270°C to 1000°C	-454°F to 1832°F
R	0°C to 1768°C	32°F to 3214°F
S	0°C to 1768°C	32°F to 3214°F
N	-210°C to 1300°C	-346°F to 2372°F
C	0°C to 2315°C	32°F to 4199°F
CJC Sensor	0°C to 90°C	32°F to 194°F

Table 1.2 RTD Temperature Ranges

Type	°C Temp Range	°F Temp Range
Platinum (385)		
100 Ohm	-200°C to +850°C	-328°F to +1562°F
200 Ohm	-200°C to +850°C	-328°F to +1562°F
500 Ohm	-200°C to +850°C	-328°F to +1562°F
1000 Ohm	-200°C to +850°C	-328°F to +1562°F
Platinum (3916)		
100 Ohm	-200°C to +630°C	-328°F to +1166°F
200 Ohm	-200°C to +630°C	-328°F to +1166°F
500 Ohm	-200°C to +630°C	-328°F to +1166°F
1000 Ohm	-200°C to +630°C	-328°F to +1166°F
Copper (426)		
10 Ohm	-100°C to +260°C	-148°F to +500°F
Nickel (618)		
120 Ohm	-100°C to +260°C	-148°F to +500°F
200 Ohm	-100°C to +260°C	-148°F to +500°F
500 Ohm	-100°C to +260°C	-148°F to +500°F
1000 Ohm	-100°C to +260°C	-148°F to +500°F
Nickel (672)		
120 Ohm	-80°C to +260°C	-112°F to +500°F
Nickel/Iron (518)		
604 Ohm	-100°C to +200°C	-148°F to +392°F

The digits in parenthesis following the RTD type represent the temperature coefficient of resistance (alpha, α), which is defined as the resistance change per Ohm per °C. For instance, Platinum 385 refers to a platinum RTD with a = 0.00385 Ohms/Ohm - °C, or simply 0.00385/°C.

Table 1.3 Millivolt Input Ranges

Stated	Actual
-50 to +50 mV	(-75 to +75 mV)
-150 to +150 mV	(-175 to +175 mV)
0 to +5.0 V	(-0.5 to +5.5 V)
1.0 to +5.0 V	(0.5 to +5.5 V)
0 to 10.0 V	(-0.5 to 10.0 V)
-10.0 to +10.0 V	(-10.0 to +10.0 V)

Table 1.4 Current Input Ranges

4 to 20 mA	(-3.5 to +21.5 mA)
0 to 20 mA	(0 to +21.5 mA)

Table 1.5 Resistance Input Range

0 to 250 Ohms
0 to 500 Ohms
0 to 1000 Ohms
0 to 2000 Ohms
0 to 3000 Ohms
0 to 4000 Ohms

All eight input channels are individually configurable for RTD, resistance, thermocouple, millivolt, volt, or milliamp input types. Each input channel provides wire-off input, over-range, and under-range detection and indication, when enabled.

Hardware Features

The module fits into any single slot for I/O modules in a ControlLogix modular system. The module has a unique generic profile which may be configured using your RSLogix 5000 programming software.

The module utilizes one removable terminal block, that provides connections for the eight input channels. There are two cold-junction compensation (CJC) sensors that compensate for the cold junction at ambient temperature rather than at freezing (0°C). There are eight current sources for supplying the RTD or resistance sensors. The module is configured through RSLogix 5000 software, defining RTD, resistance, current or voltage input paths.

Table 1.6 Hardware Features

Hardware Function
OK LED Displays communication and fault status of the module
Cal LED Displays a fault condition
Side Label (Nameplate) Provides module information
Removable Terminal Block Provides electrical connection to input devices
Door Label Permits easy terminal identification
Self Locking Tabs Secure module in chassis slot
Terminal Block Switch Locks the RTB to the module.

Diagnostic LEDs

The module contains diagnostic LEDs that help you identify the source of problems that may occur during power-up or during normal operation. Power-up and diagnostics are explained in Chapter 7, *Testing Your Module*.

System Overview

The module communicates with the ControlLogix processor and receives +5 Vdc and +24 Vdc power from the system power supply through the parallel backplane interface. You may install as many universal modules in the system as the power supply can support. Channels (0 through 7) can receive input signals from RTDs, resistance sources, thermocouples, millivolt, volt, or milliamp devices. When configured for thermocouple input types, the module converts analog input voltages into cold-junction compensated and linearized, digital temperature readings. The module uses the National Institute of Standards and Technology (NIST) linearization tables based on ITS-90 for thermocouple linearization.

When configured for RTD input types, the module converts the analog input voltages into digital temperature readings, based on the alpha type, wire type, and ohms specified. The standards used are the JIS C 1604-1997 for the Pt 385 RTD types, the JIS C 1604-1989 for the Pt 3916 RTD types, SAMA RC21-4-1966 for the 10. Cu 426 RTD, DIN 43760 Sept. 1987 for the 120. Ni 618 RTD, and MINCO Application Aid #18 May 1990 for the 120. Ni 672 RTD. When configured for millivolt, volt, milliamp, or resistance analog inputs, the module converts the analog values directly into floating point values. For those input types, the module assumes that the input signal is linear prior to input into the module.

Table 1.6 Hardware Features

Hardware Function
OK LED Displays communication and fault status of the module
Cal LED Displays a fault condition
Side Label (Nameplate) Provides module information
Removable Terminal Block Provides electrical connection to input devices
Door Label Permits easy terminal identification
Self Locking Tabs Secure module in chassis slot
Terminal Block Switch Locks the RTB to the module.

System Operation

At power-up, the module checks internal circuits, memory, and basic functions. During this time the Cal LED remains on. If the module does not find any faults, it turns off the Cal LED. After completing power-up checks, the module wait for a connection to an owner controller then valid channel configuration data from your ladder logic program. After channel configuration data is transferred, and one or more channels are enabled, the module continuously converts the inputs to floating point data for use in your ladder program.

Each time the module reads an input channel, the module tests that data for a fault, i.e. over-range, or under-range condition. If it detects an overrange or under-range condition, the module sets a unique bit in the status tags.

Module Operation

The module's input circuitry consists of eight differential analog inputs, multiplexed into an A/D converter. The A/D converter reads the analog input signals and converts them to floating point values.. The input circuitry also continuously samples the CJC sensors, if not disabled and compensates for temperature changes for thermocouples at the cold junction (terminal block). The sensors must be Spectrum Controls supplied temperature sensors. The module will not accept other CJC sensor inputs, and thermocouple inputs will not function properly if incorrect CJC sensors are used. Two CJC sensors are shipped with each module.

Compatibility with Thermocouple, Current, and Millivolt Devices & Cables

The module is compatible with the following standard types of thermocouples: B, E, J, K, N, R, S, T and C and extension wire. Refer to appendices B and C for details. The module is also compatible with a variety of voltage and current devices with an output of ± 50 , ± 150 mV, 0-5V, 1-5V, 0-10V, ± 10 V, 0-20mA, and 4-20mA. To minimize interference from radiated electrical noise, we recommend twisted-pair and highly shielded cables such as the following:

Table 1.7 Recommendations to minimize interference from radiated electrical noise

For This Type of Device We Recommend This Cable (or equivalent)
Thermocouple Type J EIL Corp. J20-5-502
Thermocouple Type K EIL Corp. K20-5-510
Thermocouple Type T EIL Corp. T20-5-502

Other Thermocouple Types consult with EIL Corp or other manufacturers mV, V, mA devices Belden 8761, shielded, twisted-pair Compatibility with RTD and Resistance devices and cables

The module is compatible 100. Platinum 385, 200. Platinum 385, 500. Platinum 385, 1000. Platinum 385, 100. Platinum 3916, 200. Platinum 3916, 500. Platinum 3916, 1000. Platinum 3916, 10. Copper 426, 120. Nickel 618 and 120. Nickel 672 RTD types and resistance inputs, and 3 possible wire types (2 wire, 3 wire, or 4 wire). Each RTD input individually supports three input pins on the terminal block: one excitation current source (EXC+), one sense positive (IN+) and one sense negative (IN-). Only those pins are connected that are required by the selected RTD or resistance wire type. For 2, 3, or 4 wire configurations, the module can support a maximum combined cable length associated with an overall cable impedance of 25 ohms or less without exceeding its input limitations. The accuracy specifications provided herein do not include errors associated with unbalanced cable impedance.

Since the operating principle of the RTD and resistance inputs is based on the measurement of resistance, take special care in selecting your input cable. For 2-wire or 3-wire configuration, select a cable that has a consistent impedance throughout its entire length. For 2-wire configurations, we recommend that you use *Belden #9501 (or equivalent)*. For 3-wire configurations, we recommend that you use *Belden #9533 (or equivalent)* for short installation runs (less than 100 feet) or use *Belden #83503 (or equivalent)* for longer runs (greater than 100 feet) and in high humidity environments.

Table 1.8 Cable Specifications

Description	Belden#9501	Belden#9533	Belden#83503
For	2-wire RTDs and potentiometers.	3-wire RTDs and potentiometers.	3-wire RTDs and Short potentiometers.
When used?	Long runs less than 100 feet runs greater than 100		

Installing And Wiring Your Module

Read this chapter to install and wire your module. This chapter covers:

- avoiding electrostatic damage
- determining power requirements
- installing the module
- wiring signal cables to the module's terminal block

Electrostatic Damage

Electrostatic discharge can damage semiconductor devices inside this module if you touch backplane connector pins. Guard against electrostatic damage by observing the following precautions:



CAUTION

ELECTROSTATICALLY SENSITIVE COMPONENTS

- Before handling the module, touch a grounded object to rid yourself of electrostatic charge.
- When handling the module, wear an approved wrist strap grounding device.
- Handle the module from the front, away from the backplane connector. Do not touch backplane connector pins.
- Keep the module in its static-shield container when not in use or during shipment.

Failure to observe these precautions can degrade the module's performance or cause permanent damage.

Power Requirements

The module receives its power through the ControlLogix chassis backplane from the fixed or modular +5 VDC and +24 VDC chassis power supply. The maximum current drawn by the module is shown in the table below.

Table 2.1. Maximum current drawn by the module

5VDC Amps	24VDC Amps
0.230	0.075

Using your module in the ControlLogix System

Place your module in any slot of a ControlLogix modular, or modular expansion chassis.

An analog I/O module translates an analog signal into, or from, a corresponding digital representation which controllers can easily operate on for control purposes.

A ControlLogix I/O module mounts in a ControlLogix chassis and uses a Removable Terminal Block (RTB) to connect all field-side wiring.

Before you install and use your module you should have already:

- installed and grounded a 1756 chassis and power supply.
- ordered and received an RTB for your application.

Important: RTBs are not included with your module purchase.

Specify Allen Bradley Part Number:

1756-TBCH - 36 position screw terminals

1756-TBS6H - 36 position press terminals

Module Installation and Removal

When installing the module in a chassis, it is not necessary to remove the terminal blocks from the module. However, if the terminal blocks are removed, use the write-on label located on the side of the terminal blocks to identify the module location and type.

Preventing Electrostatic Discharge

This module is sensitive to electrostatic discharge.



ATTENTION: Electrostatic discharge can damage integrated circuits or semiconductors if you touch backplane connector pins. Follow these guidelines when you handle the module:

- Touch a grounded object to discharge static potential
 - Wear an approved wrist-strap grounding device
 - Do not touch the backplane connector or connector pins
 - Do not touch circuit components inside the module
 - If available, use a static-safe work station
 - When not in use, keep the module in its static-shield box
-

Removal and Insertion Under Power

These modules are designed to be installed or removed while chassis power is applied.



ATTENTION: When you insert or remove a module while backplane power is applied, an electrical arc may occur. An electrical arc can cause personal injury or property damage by:

- sending an erroneous signal to your system's field devices causing unintended machine motion or loss of process control.
- causing an explosion in a hazardous environment.

Repeated electrical arcing causes excessive wear to contacts on both the module and its mating connectors. Worn contacts may create electrical resistance that can affect module operation.

Compliance to European Union Directives

If this product bears the CE marking, it is approved for installation within the European Union and EEA regions. It has been designed and tested to meet the following directives.

EMC Directive

This product is tested to meet Council Directive 89/336/EEC Electromagnetic Compatibility (EMC) and the following standards, in whole or in part, documented in a technical construction file:

EN 61010-1 and EN 61131-2, EN61000-6-2:2001, EN61000-6-4:2001
EN61010-1:2001

This product is intended for use in an industrial environment.

Low Voltage Directive

This product is tested to meet Council Directive 73/23/EEC Low Voltage, by applying the safety requirements of EN 61131-2 Programmable Controllers, Part 2 - Equipment Requirements and Tests.

For specific information required by , EN61131-2:1994 + A11:1996 + A12:2000, see the appropriate sections in this publication, as well as the following Allen-Bradley publications:

- Industrial Automation Wiring and Grounding Guidelines For Noise Immunity, publication 1770-4.1
- Automation Systems Catalog, publication B111

This equipment is classified as open equipment and must be installed (mounted) in an enclosure during operation as a means of providing safety protection.



CAUTION

POSSIBLE EQUIPMENT OPERATION

ATTENTION: The module is designed to support Removal and Insertion Under Power (RIUP). However, when you remove or insert an RTB with field-side power applied, **unintended machine motion or loss of process control can occur**. Exercise extreme caution when using this feature.



WARNING

The 1756sc-IF8U module is to be used only with the Allen-Bradley 1756 ControlLogix System.

To insert your module into the rack, follow these steps:

1. Align the circuit board of your module with the card guides at the top and bottom of the chassis.

Figure 2.1. Module insertion into a rack

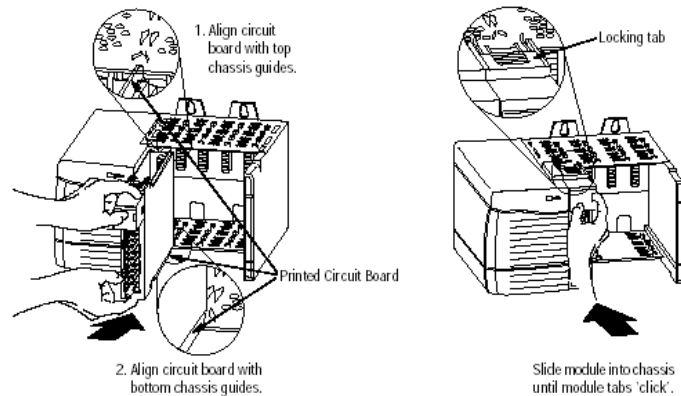

2. Key the RTB in positions that correspond to unkeyed module positions. Insert the wedge-shaped tab on the RTB with the rounded edge first. Push the tab onto the RTB until it stops.

Keying the Removable Terminal Block

Key the RTB to prevent inadvertently connecting the incorrect RTB to your module.

When the RTB mounts onto the module, keying positions will match up. For example, if you place a U-shaped keying band in position #4 on the module, you cannot place a wedge-shaped tab in #4 on the RTB or your RTB will not mount on the module.

We recommend that you use a unique keying pattern for each slot in the chassis.

1. Insert the U-shaped band with the longer side near the terminals. Push the band onto the module until it snaps into place.

Figure 2.2. Terminal block diagram with keying

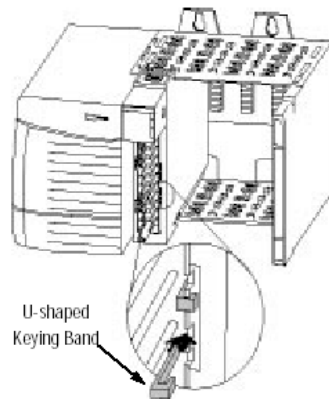

Wiring Your Module

Follow these guidelines to wire your input signal cables:

- Power, input, and output (I/O) wiring must be in accordance with Class I, Division 2 wiring methods [Article 501-4(b) of the National Electrical Code, NFPA 70] and in accordance with the authority having jurisdiction.
- Peripheral equipment must be suitable for the location in which it is used.
- Route the field wiring away from any other wiring and as far as possible from sources of electrical noise, such as motors, transformers, contactors, and ac devices. As a general rule, allow at least 6 in. (about 15.2 cm) of separation for every 120 V of power.
- Routing the field wiring in a grounded conduit can reduce electrical noise further.
- If the field wiring must cross ac or power cables, ensure that they cross at right angles.
- To limit the pickup of electrical noise, keep thermocouple, RTD, millivolt, and milliamp signal wires as far from power and load lines as possible.
- For improved immunity to electrical noise, use Belden 8761 (shielded, twisted pair) or equivalent wire for millivolt sensors; or use shielded, twisted pair thermocouple extension lead wire specified by the thermocouple or RTD manufacturer. Using the incorrect type of thermocouple extension wire or not following the correct polarity may cause invalid readings.
- Ground the shield drain wire at only one end of the cable. The preferred location is at the shield connections at the ControlLogix chassis. (Refer to IEEE Std. 518, Section 6.4.2.7 or contact your sensor manufacturer for additional details.)

- Keep all unshielded wires as short as possible.
- To limit overall cable impedance, keep input cables as short as possible. Locate your I/O chassis as near the RTD or thermocouple sensors as your application will permit.
- Tighten screw terminals with care. Excessive tightening can strip a screw. The RTB terminations can accommodate 2.1...0.25 mm² (14...22 AWG) shielded wire and a torque of 0.5 N•m (4.4 lb•in.).
- Follow system grounding and wiring guidelines found in your ControlLogix Installation and Operation Manual.

Preparing and Wiring the Cables

To prepare and connect cable leads and drain wires, follow these steps:

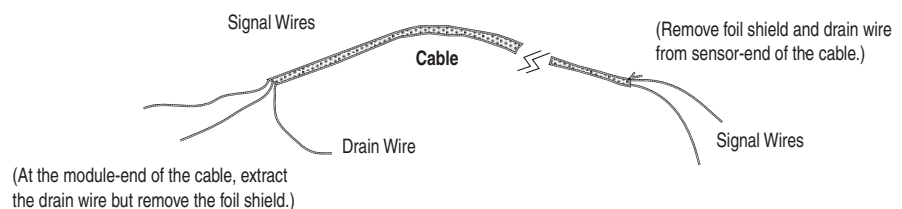

1. At each end of the cable, strip some casing to expose individual wires.
2. Trim signal wires to 5-inch lengths beyond the cable casing. Strip about 3/16 inch (4.76 mm) of insulation to expose the ends of the wires.
3. At the module-end of the cables (see figure above):
 - extract the drain wire and signal wires
 - remove the foil shield
 - bundle the input cables with a cable strap
4. Connect pairs of drain wires together, Channels 0 and 1, Channels 2 and 3, Channels 4 and 5, Channels 6 and 7. Keep drain wires as short as possible.
5. Connect the drain wires to the grounding lug on the PLC chassis.
6. Connect the signal wires of each channel to the terminal block.
Important: Only after verifying that your connections are correct for each channel, trim the lengths to keep them short. Avoid cutting leads too short.
7. At the source-end of cables from mV devices:
 - remove the drain wire and foil shield
 - apply shrink wrap as an option

- connect to mV devices keeping the leads short

Important: If noise persists, try grounding the opposite end of the cable, instead (Ground one end only.)

Terminal Block Layout

The following figure shows the general terminal block layout. The input signal type will determine which pins are used.

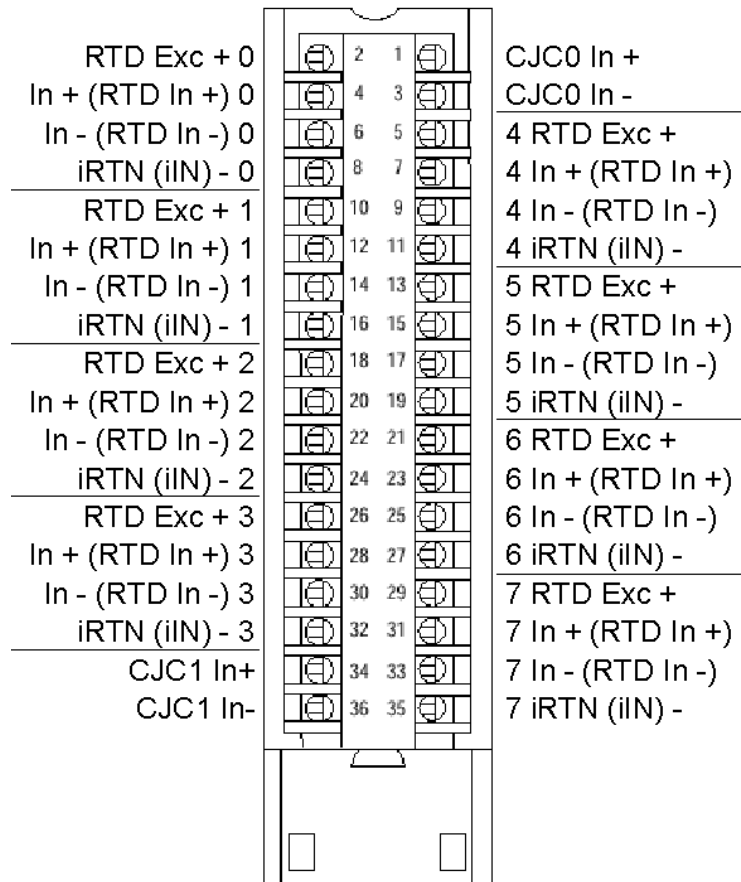

Wiring Voltage/ Current Inputs the IF8u Module

Voltage inputs use the terminal block pins labelled IN+ and IN-

Current inputs use the terminal block pins labelled IN+ and IN-

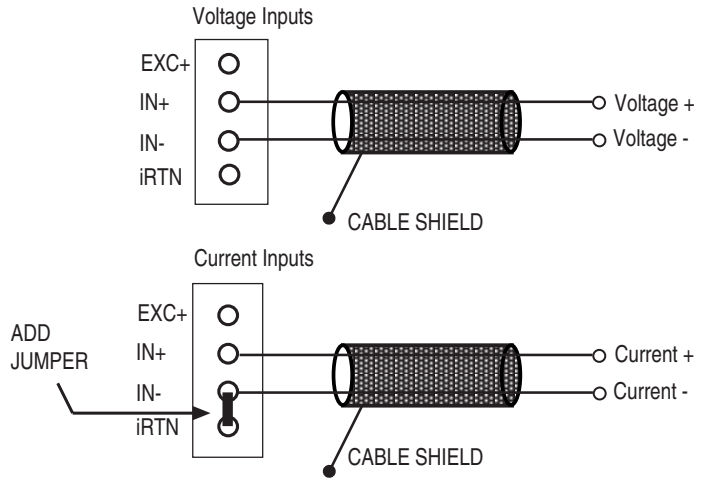

Wiring RTD or Resistance Sensors to the IF8u Module

The IF8u module supports two, three, and four wire RTDs or resistance inputs connected individually to the module as shown in the figure below.

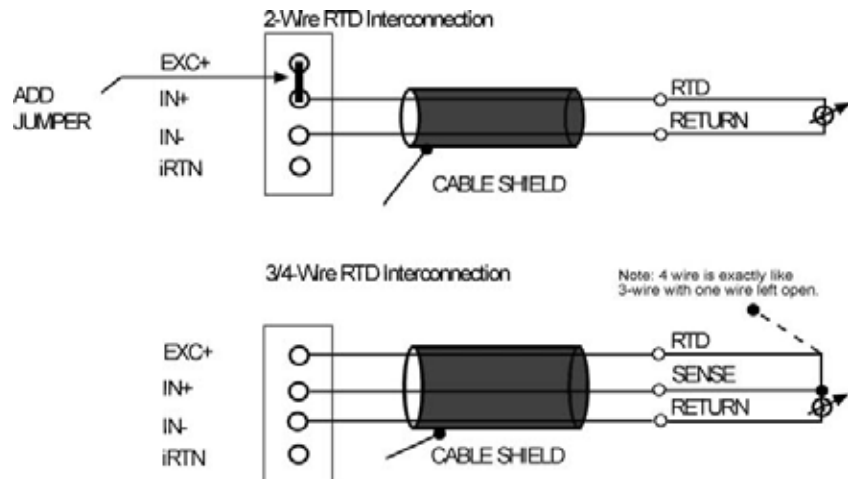

These are:

- * 2-wire RTDs, which are composed of 2 RTD lead wires (EXC+ and IN- with a jumper between EXC+ and IN+)
- * 3-wire RTDs, which are composed of a 2 Signal and 1 RTD return lead wires (EXC+ and IN+ with a the return RTD lead to IN-)
- * 4-wire RTDs, which are composed of 2 Signal and 2 RTD return lead wires (EXC+ and IN+ with a the return RTD lead to IN-) The fourth lead is not used so wiring is identical to 3 wires RTDs.
- * 2- wire Resistance, which is composed of 2 leads (EXC+ and IN- with a jumper between EXC+ and IN+)
- * 3- wire Resistance, which is composed of 3 leads (EXC+ IN+ and IN-) and the resistance lies between IN+ and IN-

In any RTD sensing system, it is important that the lead and sense wire resistances are matched as much as possible. The lead lengths, and their resulting impedances, must be matched and kept small to eliminate the introduction of connectivity errors. The 3/4-wire RTDs are the most accurate, with 2-wire RTDs being the most inaccurate. In 2-wire the lead resistance adds error to the resulting degree reading. With a 1.008mA current source, 1Ω of lead resistance adds 1.008μV, or 2.82°C error, with the 100Ω 385 alpha type. To gain an understanding of how lead resistance affects RTD readings, the μV/C for each RTD type is listed below.

RTD Type	Current Source	V/°C
100Ω Pt 385	1.008mA	357μV/°C
200Ω Pt 385	1.008mA	714μV/°C
500Ω Pt 385	252μA	447μV/°C
1000Ω Pt 385	252μA	893μV/°C
100Ω Pt 3916	1.008mA	377μV/°C
200Ω Pt 3916	1.008mA	754μV/°C
500Ω Pt 3916	252μA	472μV/°C
1000Ω Pt 3916	252μA	941μV/°C
120Ω Ni 618	1.008mA	694μV/°C
200Ω Ni 618	1.008mA	1389μV/°C
500Ω Ni 618	252μA	867μV/°C
1000Ω Ni 618	252μA	1733μV/°C
10Ω Cu 426	252μA	9.7μV/°C
120Ω Ni 672	1.008mA	929μV/°C

The accuracies specified for the IF8u RTDs do not include errors due to lead resistance imbalances.

Important: To ensure temperature or resistance value accuracy, the resistance difference of the cable lead wires must be equal to or less than 0.01 ohms.

Important: Keep total lead resistance as small as possible and less than 25 ohms.

There are several ways to insure that the lead values match as closely as possible. They are as follows:

- * Use quality cable that has a small tolerance impedance rating.
- * Use a heavy gauge lead wire which has less resistance per foot.

Wiring Thermocouples to the IF8u Module

One end of thermocouple to IN+

Other end of thermocouple to IN-

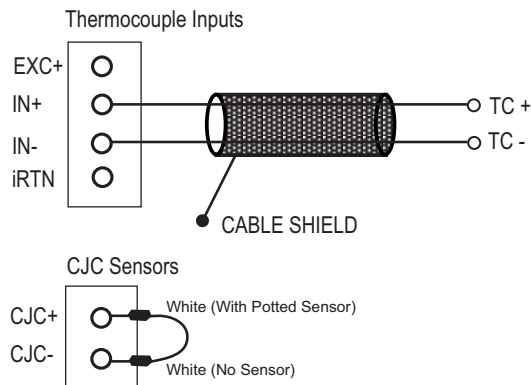

For cold junction compensation be sure the two supplied thermistors are connected. One should be connected between CJC0-IN+ and CJC0-IN- and the other should be connected between CJC1-IN+ and CJC1-IN-. Also be sure configuration tag ".CJDisable" is set to zero to perform cold junction compensation for thermocouple inputs

Cold Junction Compensation (CJC)



CAUTION

POSSIBLE EQUIPMENT OPERATION

Both CJs are critical to ensure accurate thermocouple input readings at each channel.

Failure to observe this precaution can cause unintended equipment operation and damage.

Operation Within the ControlLogix System

This chapter describes how the 1756sc-IF8u analog module works within the ControlLogix system. This chapter covers:

- Ownership and connections to the module
- Direct connections
- Listen only mode
- Configuration changes with multiple owners.

Ownership and Connections

Every I/O module in the ControlLogix system must be owned by a Logix5550 Controller to be useful. This owner-controller stores configuration data for every module that it owns and can be local or remote in regard to the I/O module's position. The owner sends the I/O module configuration data to define the module's behavior and begin operation within the control system. Each ControlLogix I/O module must continuously maintain communication with its owner to operate normally.

Typically, each module in the system will have only 1 owner. Input modules can have more than 1 owner. Output modules, however, are limited to a single owner.

Using RSNetWorx and RSLogix 5000

The I/O configuration portion of RSLogix5000 generates the configuration data for each I/O module in the control system, whether the module is located in a local or remote chassis. A remote chassis, also known as networked, contains the I/O module but not the module's owner controller. Configuration data is transferred to the controller during the program download and subsequently transferred to the appropriate I/O modules. I/O modules in the same chassis as the controller are ready to run as soon as the configuration data has been downloaded. You must run RSNetWorx to enable I/O modules in the networked chassis.

Running RSNetWorx transfers configuration data to networked modules and establishes a Network Update Time (NUT) for ControlNet that is compliant with the desired communications options specified for each module during configuration. If you are not using I/O modules in a networked chassis, running RSNetWorx is not necessary. However, anytime a controller references an I/O module in a networked chassis, RSNetWorx must be run to configure ControlNet. Follow these general guidelines when configuring I/O modules:

1. Configure all I/O modules for a given controller using RSLogix 5000 and download that information to the controller.

2. If the I/O configuration data references a module in a remote chassis, run RSNetWorx.

Important: RSNetWorx **must** be run whenever a new module is added to a networked chassis. When a module is permanently removed from a remote chassis, we recommend that RSNetWorx be run to optimize the allocation of network bandwidth.

Direct Connections

A **direct connection** is a real-time data transfer link between the controller and the device that occupies the slot that the configuration data references. When module configuration data is downloaded to an owner-controller, the controller attempts to establish a direct connection to each of the modules referenced by the data.

If a controller has configuration data referencing a slot in the control system, the controller periodically checks for the presence of a device there. When a device's presence is detected, the controller automatically sends the configuration data. If the data is appropriate to the module found in the slot, a connection is made and operation begins. If the configuration data is not appropriate, the data is rejected and an error message displays in the software. In this case, the configuration data can be inappropriate for any of a number of reasons.

The controller maintains and monitors its connection with a module. Any break in the connection, such as removal of the module from the chassis while under power, causes the controller to set fault status bits in the data area associated with the module. The RSLogix 5000 software may monitor this data area to announce the modules' failures.

Module Operation

In traditional I/O systems, controllers poll input modules to obtain their input status. Analog input modules in the ControlLogix system are not polled by a controller once a connection is established. The modules multicast their data periodically. Multicast frequency depends on the options chosen during configuration and where in the control system that input module physically resides. An input module's communication, or multicasting, behavior varies depending upon whether it operates in the local chassis or in a remote chassis. The following sections detail the differences in data transfers between these set-ups.

Modules in a Local Chassis

When a module resides in the same chassis as the owner controller, the following two configuration parameters will affect how and when the input module multicasts data:

- Real Time Sample (RTS) configured via Real Time Sample tag.
- Requested Packet Interval (RPI) configured via I/O module properties.

Real Time Sample (RTS)

This configurable parameter instructs the module to perform the following operations:

1. **scan all** of its input channels and store the data into on-board memory
2. multicast the updated channel data (as well as other status data) to the backplane of the local chassis

Requested Packet Interval (RPI)

This configurable parameter also instructs the module to multicast its channel and status data to the local chassis backplane.

The RPI instructs the module to multicast the **current contents** of its on-board memory when the RPI expires, (i.e. the module does not update its channels prior to the multicast).

Important: The RPI value is set during the initial module configuration using RSLogix 5000.

It is important to note that the module will reset the RPI timer each time an RTS is performed. This operation dictates how and when the owner controller in the local chassis will receive updated channel data, depending on the values given to these parameters. If the RTS value is less than or equal to the RPI, each multicast of data from the module will have updated channel information. In effect, the module is only multicasting at the RTS rate.

If the RTS value is greater than the RPI, the module will multicast at both the RTS rate and the RPI rate. Their respective values will dictate how often the owner controller will receive data and how many multicasts from the module contain updated channel data. Note: Even though data may be transferred at the RPI rate, the data will be identical to the previous RTS data transfer.

Modules in a Remote Chassis

If an input module resides in a networked chassis, the role of the RPI and the module's RTS behavior change slightly with respect to getting data to the owner. The RPI and RTS intervals still define when the module will multicast data **within its own chassis** (as described in the previous section), but only the value of the RPI determines how often the owner controller will receive it over the network.

When an RPI value is specified for an input module in a remote chassis, in addition to instructing the module to multicast data within its own chassis, the RPI also "reserves" a spot in the stream of data flowing across the ControlNet network.

The timing of this "reserved" spot may or may not coincide with the exact value of the RPI, but the control system will guarantee that the owner controller will receive data **at least as often** as the specified RPI.

The “reserved” spot on the network and the module’s RTS are asynchronous to each other. This means there are Best and Worst Case scenarios as to when the owner controller will receive updated channel data from the module in a networked chassis.

Best Case RTS Scenario

In the Best Case scenario, the module performs an RTS multicast with updated channel data just before the “reserved” network slot is made available. In this case, the remotely located owner receives the data almost immediately.

Worst Case RTS Scenario

In the Worst Case scenario, the module performs an RTS multicast just after the “reserved” network slot has passed. In this case, the owner-controller will not receive data until the next scheduled network slot.

Because it is the RPI and NOT the RTS which dictates when the module’s data will be sent over the network, we recommend the RPI value be set LESS THAN OR EQUAL TO the RTS to make sure that updated channel data is received by the owner controller with each receipt of data.

Listen-Only Mode

Any controller in the system can **listen** to the data from any I/O module (e.g. input data or “echoed” output data) even if the controller does not own the module (i.e. it does not have to hold the module’s configuration data to listen to the module).

The “listen only” mode is set during the I/O configuration process.

Choosing a ‘Listen-Only’ mode option allows the controller and module to establish communications without the controller sending any configuration data. In this instance, another controller owns the module being listened to.

Important: Controllers using the Listen-Only mode continue to receive data multicast from the I/O module as long as a connection between an owner and I/O module is maintained. If the connection between all owners and the module is broken, the module stops multicasting data and connections to all ‘Listening controllers’ are also broken.

Multiple Owners of Input Modules

Because ‘Listening controllers’ lose their connections to modules when communications with the owner stop, the ControlLogix system will allow you to define more than one owner for input modules.

Important: Only input modules can have multiple owners. If multiple owners are connected to the same input module, they **must maintain identical configuration** for that module.

In the example below, Controller A and Controller B have both been configured to be the owner of the input module.

When the controllers begin downloading configuration data, both try to establish a connection with the input module. Whichever controller's data arrives first establishes a connection. When the second controller's data arrives, the module compares it to its current configuration data (the data received and accepted from the first controller).

If the configuration data sent by the second controller matches the configuration data sent by the first controller the connection is also accepted. If any parameter of the second configuration data is different from the first, the module rejects the connection and the user is informed by an error in the software.

The advantage of multiple owners over a 'Listen-only' connection is that now either of the controllers can lose the connection to the module and the module will continue to operate and multicast data to the system because of the connection maintained by the other owner controller.

Note: The previous discussion of multiple owners assumes the configuration tag ".configrevnumber" is set to 1. Operation differs if the tag is set to 0. Refer to Chapter 5 for descriptions of this tag's settings.

Configuration Changes in an Input Module with Multiple Owners

You must be careful when changing an input module's configuration data in a multiple owner scenario. When the configuration data is changed in one of the owners, for example, Controller A, and sent to the module, that configuration data is accepted as the new configuration for the module. Controller B will continue to listen, unaware that any changes have been made in the module's behavior.

Important: When changing configuration for a module with multiple owners, we recommend the connection be inhibited. To prevent other owners from receiving potentially erroneous data, as described above, the following steps **must be followed** when changing a module's configuration in a multiple owner scenario when online:

1. For each owner controller, inhibit the controller's connection to the module in the software on the I/O Module Connection tab.
2. Make the appropriate configuration data changes in the software.
3. Repeat steps 1 and 2 for all owner controllers, making the **exact same changes** in all controllers.
4. Uncheck the Inhibit box in each owner's configuration to reconnect each module.

Programming Your Module

This chapter explains how to program your module in the ControlLogix system. It also describes how the module's input configuration are incorporated into your ladder logic program. Topics discussed include:

- importing the module's configuration profile
- reviewing accessing and altering configuration options.
- configuring the modules input type and filter settings
- configuring alarms and limits

Module Installation

To incorporate the module into the system, you must use the RSLogix 5000 programming software. If you're using RSLogix 5000 version 15 or greater, an AOP (Add-On-Profile) is available and can be downloaded from our website at (<http://www.spectrumcontrols.com/downloads.htm>). The AOP allows you to add the IF8U to the RSLogix 5000 pick list and contains custom configuration screens for the module. If you do plan to use the AOP, you can skip the remainder of this chapter.

For those that plan to use RSLogix 5000 version 14 or older, the generic module profile must be used to add the IF8U to a new or existing project. An RSLogix 5000 sample project utilizing the generic module profile is available for download on our website at (www.spectrumcontrols.com/downloads.htm). The ladder sample contains user defined input and configuration tags used to configure and read analog data from the IF8U module. The configuration tags control features such as the modules input type, channel input range, data format, filter frequency, etc.

Adding Your Module to a Project

The module has a unique set of tag definitions which are used to configure specific features. Chapter 5, *Channel Configuration, Data, and Status*, gives you detailed information about the data content of the configuration. These values are set using your programming software and ladder logic. Before you can use these feature you must first include the module into the project.

1. Open the sample project with the IF8u information. Open your project. Drag and drop the IF8u module into the I/O configuration section of your project.

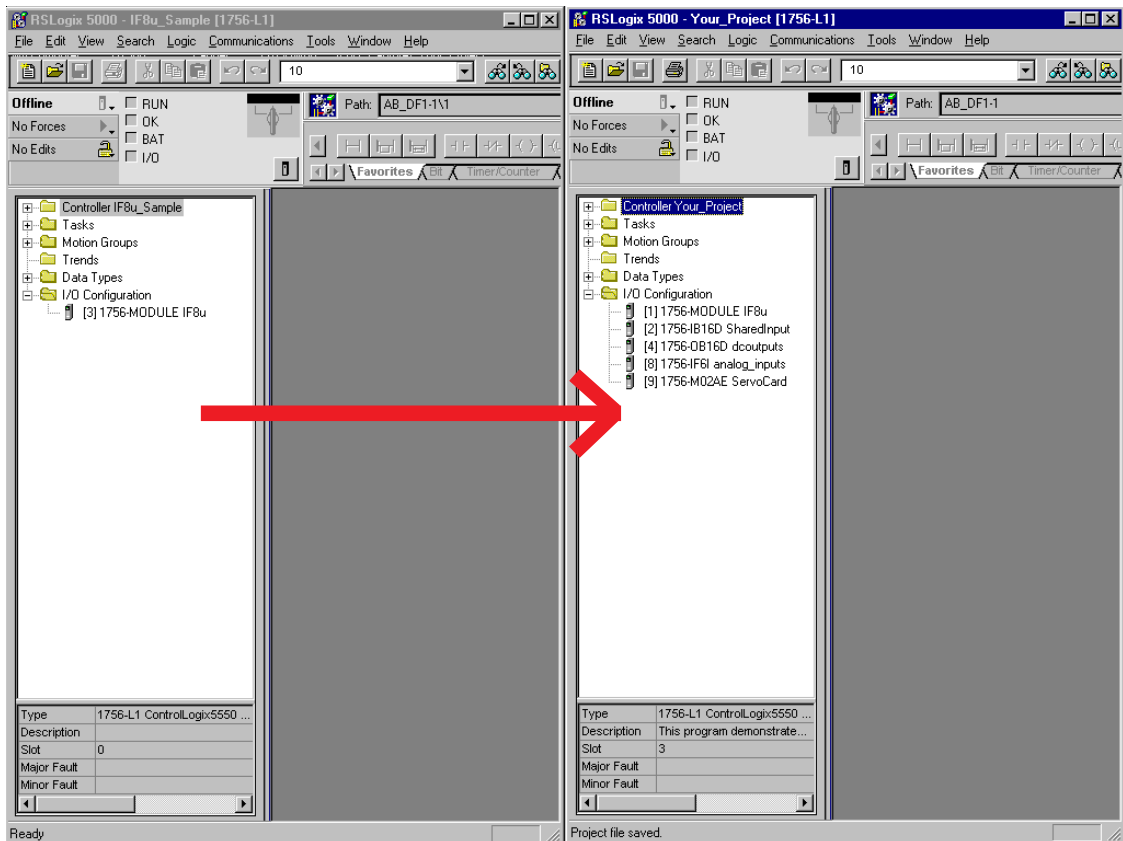

1. Open the sample project.
2. Open your new project.
3. Click once on the IF8u in the sample project.
4. Drag and drop it into the I/O Configuration section of your project.

See Appendix D for the I/O module property details.

2. Drag and drop the IF8u user-defined data types from the sample project into your project.

There are four IF8u user defined data types that need to be moved.

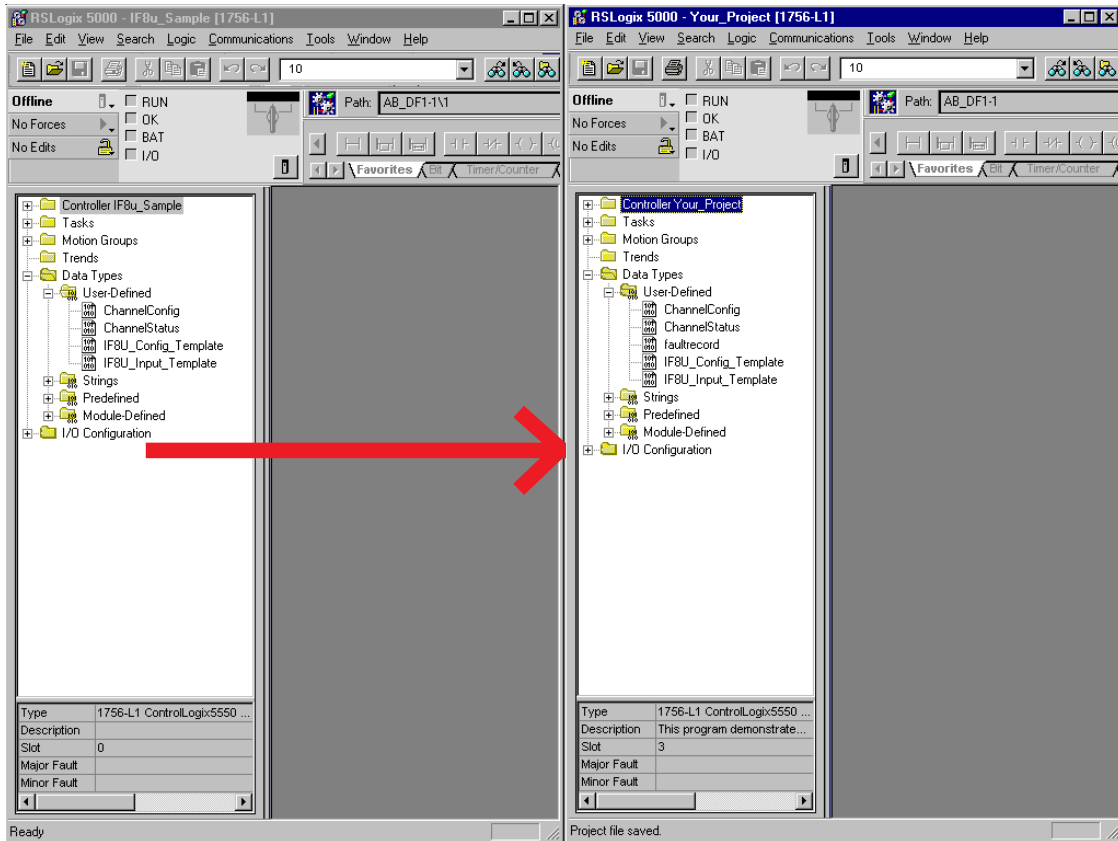

ChannelConfig
 ChannelStatus
 IF8u_Config_Template
 IF8u_Input_Template

1. Click on the data type
2. Drag it into your new project.
3. Continue to drag and drop the data types until all four have been moved.

Note: These can only be moved one at a time.

3. Drag and drop the controller configuration tags from the sample project into your project.

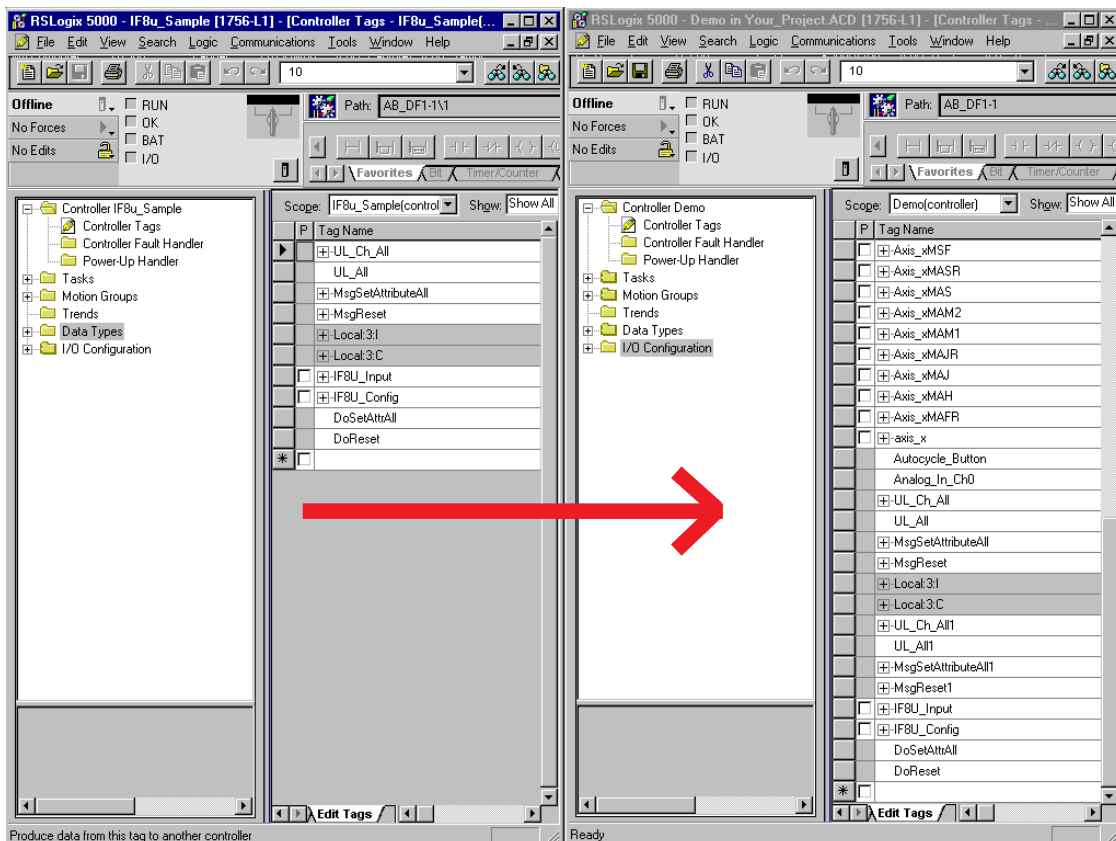

1. Right click on the Controller Tags item of the sample project and select edit.
2. Right click on the Controller Tags item of your project and select edit.
3. Scroll down to the Controller tags of the sample project and select all the tags by highlighting them.
4. Drag and drop these tags into your project.

Note: IF8u_Config and IF8u_Input contain the configuration, data and status tags for the IF8u module. The other tags are used for performing various functions to your module via ladder logic.

Note: Be sure all tags are displayed before moving them. Select Display All from the Edit drop down window.

Note: The “Local:3:I” and “Local:3:C” tags are not copied.

4. Create a new ladder logic routine in your project.

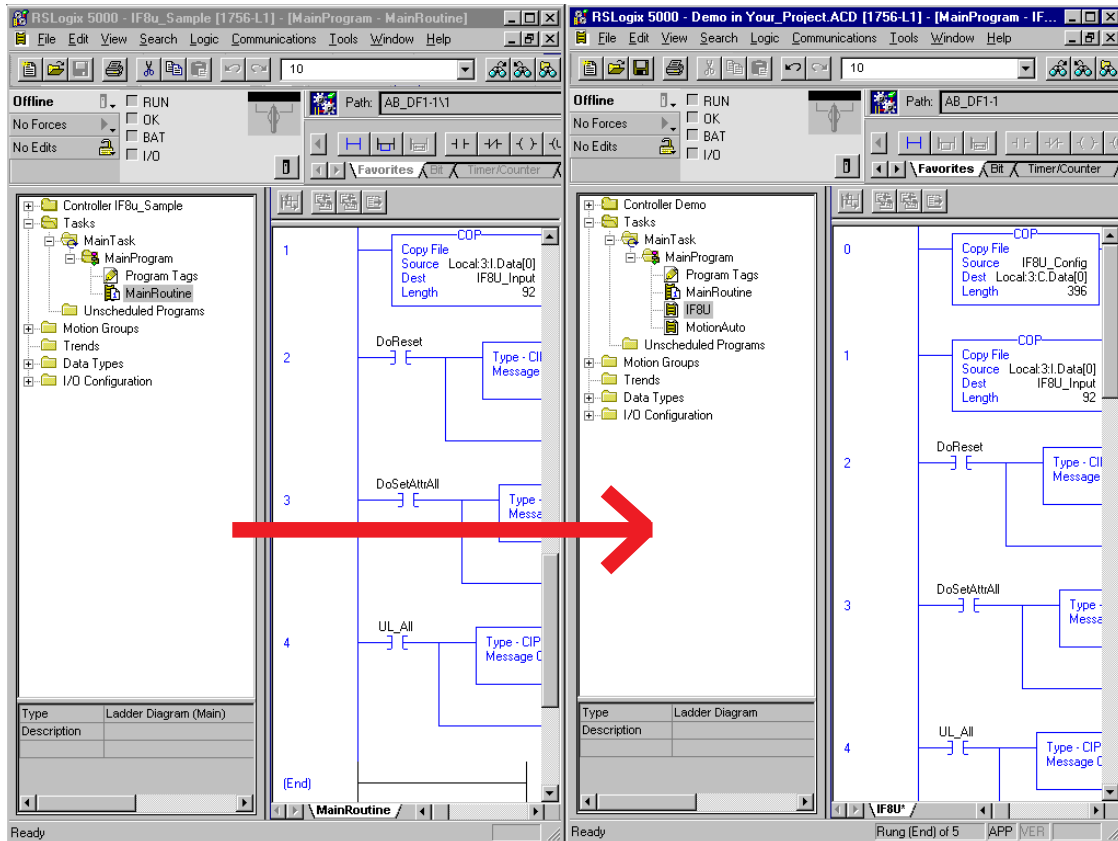

1. In your project, right mouse click on the MainRoutine item and select “New Routine...” IF8u was entered in the example above.

2. Double click on the MainRoutine item in the sample project and then double click on the added new routine in your project to display their corresponding ladder logic.

3. Left mouse inside the MainProgram ladder logic in the sample project and press ctrl-A to select all the rungs.

4. Drag and drop these rungs over and add them to the new routine’s ladder logic. Note: You will need to delete the one blank “solid bar” rung either at the top or bottom of the routine which was left over from the newly created routine.

5. Now add a JSR ladder instruction in your MainRoutine which calls this routine.

Note: RSLogix 5000 will verify the ladder logic sample. You may receive errors regarding invalid tags. You will need to change the slot addressing in the logic to coordinate with the location of the IF8u.

This completes the installation of module in the system

Configuring module attributes: Configuration Tags

The module has settings that are global and channel specific. These are accessed via the controller tags. Specific information regarding these tag settings may be found in Chapter 5.

Global module tags

These settings are used globally by the module. They control features such as the module autocalibration modes, and various other attributes.

+	IF8U_Input	{...}	{...}		IF8U_Input_Template
▶	IF8U_Config	{...}	{...}		IF8U_Config_Template
	IF8U_Config.ConfigRevNumber	0		Decimal	SINT
	IF8U_Config.RemoteTermination	0		Decimal	BOOL
	IF8U_Config.CJDisable	1		Decimal	BOOL
	IF8U_Config.TempMode	0		Decimal	BOOL
	IF8U_Config.DisableCyclicAutoCal	0		Decimal	BOOL
	IF8U_Config.CyclicAutoCalPeriod	1		Decimal	INT
	IF8U_Config.RealTimeSample	10		Decimal	INT
	IF8U_Config.CJOffset	0.0		Float	REAL
	IF8U_Config.ChannelConfig	{...}	{...}		ChannelConfig[8]

Channel Specific Tags

These settings control channel specific behavior such as input type, range, filter frequency, units, and alarms. Specific information regarding these tags may be found in Chapter 5.

IF8U_Config.ChannelConfig	{...}	{...}		ChannelConfig[8]
IF8U_Config.ChannelConfig[0]	{...}	{...}		ChannelConfig
IF8U_Config.ChannelConfig[0].DisableChannel	0		Decimal	BOOL
IF8U_Config.ChannelConfig[0].RTD3Wire	0		Decimal	BOOL
IF8U_Config.ChannelConfig[0].DisableCyclicLead	0		Decimal	BOOL
IF8U_Config.ChannelConfig[0].AlarmEnable	0		Decimal	BOOL
IF8U_Config.ChannelConfig[0].ProcessAlarmLatch	0		Decimal	BOOL
IF8U_Config.ChannelConfig[0].RateAlarmLatch	0		Decimal	BOOL
IF8U_Config.ChannelConfig[0].ADCFilter	0		Decimal	SINT
IF8U_Config.ChannelConfig[0].RangeType	5		Decimal	SINT
IF8U_Config.ChannelConfig[0].TenOhmOffset	0		Decimal	INT
IF8U_Config.ChannelConfig[0].DigitalFilter	0		Decimal	INT
IF8U_Config.ChannelConfig[0].RateAlarmLimit	0.0		Float	REAL
IF8U_Config.ChannelConfig[0].LowSignal	0.0		Float	REAL
IF8U_Config.ChannelConfig[0].HighSignal	0.0		Float	REAL
IF8U_Config.ChannelConfig[0].LowEngineering	0.0		Float	REAL
IF8U_Config.ChannelConfig[0].HighEngineering	0.0		Float	REAL
IF8U_Config.ChannelConfig[0].LAlarmLimit	0.0		Float	REAL
IF8U_Config.ChannelConfig[0].HAlarmLimit	0.0		Float	REAL
IF8U_Config.ChannelConfig[0].LLAlarmLimit	0.0		Float	REAL
IF8U_Config.ChannelConfig[0].HHAlarmLimit	0.0		Float	REAL
IF8U_Config.ChannelConfig[0].AlarmDeadband	0.0		Float	REAL
IF8U_Config.ChannelConfig[1]	{...}	{...}		ChannelConfig
IF8U_Config.ChannelConfig[2]	{...}	{...}		ChannelConfig

Data Tags

These tags represent the process data values in their final form.

IF8U_Input.ChannelStatus	{...}	{...}		ChannelStatus[8]
IF8U_Input.ChannelData	{...}	{...}	Float	REAL[8]
IF8U_Input.ChannelData[0]	-1.8089085		Float	REAL
IF8U_Input.ChannelData[1]	-1.7726774		Float	REAL
IF8U_Input.ChannelData[2]	-1.7784147		Float	REAL
IF8U_Input.ChannelData[3]	-1.7653885		Float	REAL
IF8U_Input.ChannelData[4]	-1.7809124		Float	REAL
IF8U_Input.ChannelData[5]	-1.7705994		Float	REAL
IF8U_Input.ChannelData[6]	5.250394		Float	REAL
IF8U_Input.ChannelData[7]	-1.7382765		Float	REAL

Status Tags

These tags report module status such as alarm conditions, faults, and errors.

	IF8U_Input.ChannelStatus	{...}	{...}		ChannelStatus[8]
▶	IF8U_Input.ChannelStatus[0]	{...}	{...}		ChannelStatus
	IF8U_Input.ChannelStatus[0].Underrange	0	Decimal		BOOL
	IF8U_Input.ChannelStatus[0].Ovrange	0	Decimal		BOOL
	IF8U_Input.ChannelStatus[0].CalFault	0	Decimal		BOOL
	IF8U_Input.ChannelStatus[0].RateAlarm	0	Decimal		BOOL
	IF8U_Input.ChannelStatus[0].LAlarm	0	Decimal		BOOL
	IF8U_Input.ChannelStatus[0].HAlarm	0	Decimal		BOOL
	IF8U_Input.ChannelStatus[0].LLAlarm	0	Decimal		BOOL
	IF8U_Input.ChannelStatus[0].HHAAlarm	0	Decimal		BOOL
	IF8U_Input.ChannelStatus[0].Status	0	Decimal		INT
	IF8U_Input.ChannelStatus[1]	{...}	{...}		ChannelStatus
	IF8U_Input.ChannelStatus[2]	{...}	{...}		ChannelStatus
	IF8U_Input.ChannelStatus[3]	{...}	{...}		ChannelStatus
	IF8U_Input.ChannelStatus[4]	{...}	{...}		ChannelStatus
	IF8U_Input.ChannelStatus[5]	{...}	{...}		ChannelStatus
	IF8U_Input.ChannelStatus[6]	{...}	{...}		ChannelStatus

Configuration, Data, and Status Tags

Read this chapter to:

- send configuration data to the module
- configure global module properties
- configure each input channel
- check each input channel's data
- check module and individual channel status

This chapter outlines the detailed settings for the 1756sc-IF8u. These settings determine the modules input types, filter frequencies, scan rates, and various attributes. Detailed descriptions of these settings are available in the Tag Definition section of this chapter.

Note: An AOP (Add-On_Profile) is available for the 1756sc-IF8U and can be downloaded from our website at (<http://www.spectrumcontrols.com/downloads.htm>).

Note: The following format is used to describe tags

Tag Name	Range	Data Type
-----------------	--------------	------------------

Send Configuration Data to the Module

After changing the configuration tags in this chapter you must then send them to the module. To do this you may perform any of these operations:

1. Inhibit then un-inhibit the module via the module properties dialog, Connection Tab
2. Reset the module via the modules properties dialog. Module Info tab.
3. Reset the module via ladder logic. See the "DoReset" rung in the sample ladder project.
4. Perform a "Set Attribute All" or Module Reconfigure message instruction via ladder logic. Refer to your sample program for information about the "DoSetAttrAll" command.

Note: If an invalid configuration is sent to the module a connection error will occur. See chapter 7 for a list of error codes.

Configuration Tags

The following Global Module Settings and Channel Specific Settings sections allow custom configuration of the module. These tags can be found within the IF8u_config controller tag.

Global Module Settings

The following tag settings are module related:

Configuration Management

.ConfigRevNumber 0, 1 BOOL

0: The module will always accept this configuration if valid. This value must be used for on-the-fly configuration changes.

1: In multiple owner systems if there is already a connection to the module then this configuration must match the one of the current connection in order for this controller to connect to the module. Channel On/Off

Note: The Module Reconfigure message instruction sets this parameter to zero.

Temperature Measurement:

.RemoteTermination 0, 1 BOOL

Not Used.

.CJDisable 0, 1 BOOL

0: The cold junction compensation terminal block thermistors will be read. Thermocouple input values will be compensated based on the thermistor readings.

1: The cold junction compensation thermal block thermistors will not be read. Thermocouple input values will be compensated with the default 25 degC value plus CJOffset.

Note: 2 thermistors have been provided with the module to be installed on your terminal block if cold junction compensation is to be used.

.TempMode 0, 1 BOOL

0: Temperatures for thermocouples, RTDs and the cold junction thermistors will be displayed in degrees Celsius.

1: Temperatures for thermocouples, RTDs and the cold junction thermistors will be displayed in degrees Fahrenheit.

.CJOffset -25 to +65 degC REAL
 -45 to + 117 degF

A temperature offset added to the cold junction compensation temperature values. This is interpreted as degrees C if the .TempMode = 0 and degrees F if the .TempMode = 1.

Module Sampling Time

The universal module update time is defined as the time required for the module to sample and convert the input signals of all enabled input channels and make the resulting data values available to the processor. The sample time is influenced by the input type, filter frequency, CJC acquisition (if enabled) and autocal configuration settings. For example, when thermocouples are selected, it is necessary to perform a cold junction compensation, (CJC), measurement to obtain best possible accuracy. This CJC measurement occurs in a systematic fashion and adds approximately 26ms to the update time. The following tables illustrate the components used to calculate typical channel update times.

Overhead:

5 ms - This must be included in all calculations and represents backplane communication and other service routines within the module.

Filter Frequency:

The channel filter frequency will impact timing. The following table shows associated time adders based on frequency selection.

Filter	Additional Time
10Hz	125 ms per channel
50/60Hz	26 ms per channel
100Hz	18 ms per channel
250Hz	10 ms per channel
1kHz	6 ms per channel

Input Type:

Each input type has a specific settling time. Select each channel input type and add the time value.

Time (ms)	Type	Tag: .RangeType
0	All voltage, current, and thermocouple types	
3	100_Pt_385	8
3	100_Pt_392	12
3	120_Ni_618	16
3	120_Ni_672	20
3	10_Cu_426	21
3	604_NiFe_518	22
3	0_250_Ohm	23
3	0_500_Ohm	24
4	200_Pt_385	9
4	500_Pt_385	10
4	200_Pt_392	13
4	500_Pt_392	14
4	200_Ni_618	17
4	500_Ni_618	18
4	0_1000_Ohm	25
4	0_2000_Ohm	26
8	1000_Pt_385	11
8	1000_Pt_392	15
8	1000_Ni_618	19
8	0_3000_Ohm	27
8	0_4000_Ohm	28

Example 1:

4 channels with 200 Ohm PT 385 RTD (Input Type 9) at 100Hz filter =
 $18\text{ms} + 4\text{ms} = 22\text{ms} * 4 \text{ channels} = 88\text{ms}$
 2 channels of voltage at 1kHz = $2 * 6\text{ms} = 12\text{ms}$
 2 thermocouples at 250Hz = $2 * 10\text{ms} = 20\text{ms}$

Total = 5ms (overhead) + 26ms (CJC) + 88ms + 12ms + 20ms = 151ms
 (Actual measured = 158ms)

Example 2:

8 channels, 0-4000 ohm (type 28) at 250Hz = $10\text{ms} + 8\text{ms} = 18\text{ms} * 8 = 144\text{ms} + 5\text{ms} = 149\text{ms}$. (Actual measured = 117ms)

Note: This is approximation only. The time changes because the software does not need to spend time setting up the ADC for another filter frequency if it is the same as the previous channel. The same applies for the the gain settings, etc. Example 2 illustrates there is a significant savings because the filter frequency and input type are the same.

Note: If the autocalibration is enabled the module sampling time will increase by as much as 500ms when autocalibration is being performed.

.RealTimeSample 10-30,000 ms INT

The time in milliseconds that updated input data is to be sent from the module to the controller. If this value is smaller than the minimum update time to scan all input channels, then the actual rate will be greater than this value. In this case you may determine what the actual sample time is by subtracting two successive values of the .RollingTimeStamp input tag.

Real Time Sampling (RTS) and Requested Packet Interval (RPI)

This RealTimeSample tag instructs the module to scan its input channels and obtain all available data. After the channels are scanned, the module multicasts that data. This feature is used on a module-wide basis.

During module configuration, you specify a Real Time Sampling (RTS) period via the .RealTimeSample tag and a Requested Packet Interval (RPI) period. Both of these features instruct the module to multicast data, but only the RTS feature instructs the module to scan its channels before multicasting.

You may access the RPI in the Module Properties menu.

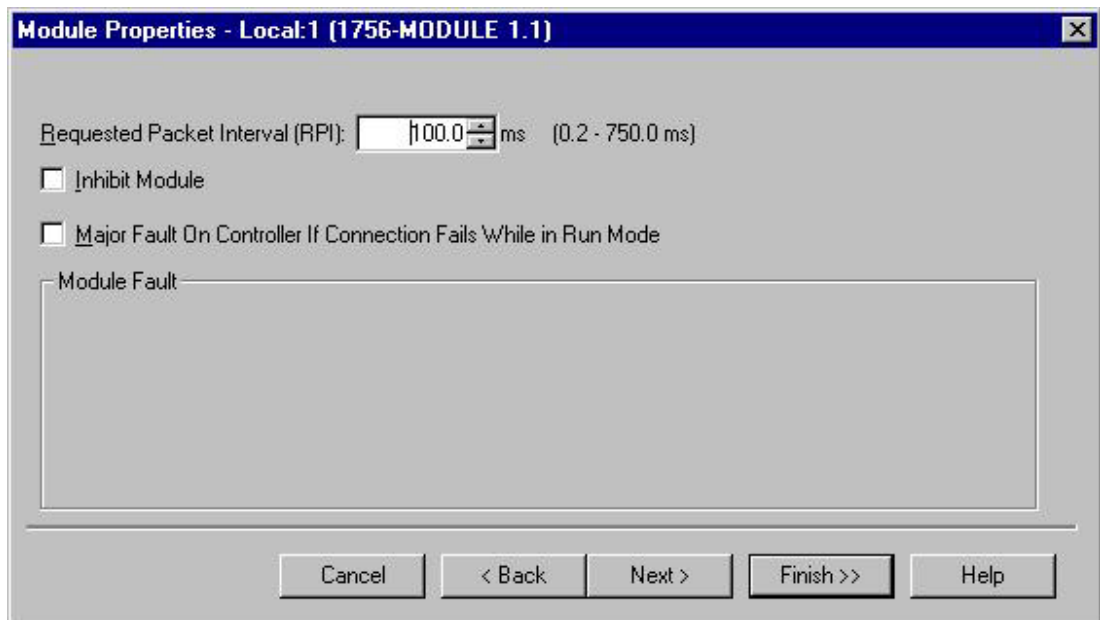

Automatic Calibration:

Autocalibration is an automated input path calibration. This insures best possible accuracy under varying application conditions. Autocalibration may be turned on or off. When autocalibration is active you may also set the interval at which the calibration occurs.

.DisableCyclicAutocal 0, 1 BOOL

0: Module auto-calibration is performed on power up, reset, and reconfiguration as well as according to the .CyclicAutocalPeriod.

1: Module auto-calibration is only performed on module power-up, reset, and reconfiguration.

Note: Changing the following tags via the set attribute all or module reconfiguration message will not cause the auto-calibration to be performed upon acceptance of the configuration.

.Alarm Enable	.ProcessAlarmLatch	.RateAlarmLatch
.TenOhmOffset	.DigitalFilter	.RateAlarmLimit
.LowSignal	.HighSignal	.LowEngineering
.HighEngineering	.LAlarmLimit	.HighAlarmLimit
.LLAlarmLimit	.HHAlarmLimit	.AlarmDeadband

.CyclicAutocalPeriod 0-3 INT

Perform module auto-calibration:

0: Only on powerup and reset.

1: Every 1 minute.

2: Every 10 minutes.

3: Every 30 minutes.

Note: Options 1 through 3 are not valid if cyclic autocal is disabled.

Channel Specific Settings

The following settings allow you to configure individual channel parameters. Each channel, 0 through 7, has these tags.

Channel On/Off:

.DisableChannel 0, 1 BOOL

0: Channel is enabled.

1: Channel is disabled.

You may decrease the module sampling time by disabling unused channels.

Input Range/Type

.RangeType 0-37 INT

You can select from a series of operational ranges for **each channel** on your module. The range designates the minimum and maximum signals that are detectable by the module. In the case of thermocouple or RTD sensors the selected type dictates the linearization curve of the particular sensor.

0 = -0.05 to 0.05V (-0.075 to 0.075V)	19 = RTD 1000Ω Ni 618
1 = -0.15 to 0.15V (-0.175 to 0.175V)	20 = RTD 120Ω Ni 672
2 = 0 to 5V (-0.5 to 5.5V)	21 = RTD 10Ω Cu 426
3 = 1 to 5V (0.5 to 5.5V)	22 = RTD 604Ω Ni-Fe 518
4 = 0 to 10V (-0.5 to 10.0V)	23 = Resistance 0 to 250Ω
5 = -10.0 to 10.0V	24 = Resistance 0 to 500Ω
6 = 0 to 20mA (0 to 21.5mA)	25 = Resistance 0 to 1000Ω
7 = 4 to 20mA (3.5 to 21.5mA)	26 = Resistance 0 to 2000Ω
8 = RTD 100Ω Pt 385	27 = Resistance 0 to 3000Ω
9 = RTD 200Ω Pt 385	28 = Resistance 0 to 4000Ω
10 = RTD 500Ω Pt 385	29 = TC Type J
11 = RTD 1000Ω Pt 385	30 = TC Type K
12 = RTD 100Ω Pt 3916	31 = TC Type T
13 = RTD 200Ω Pt 3916	32 = TC Type E
14 = RTD 500Ω Pt 3916	33 = TC Type R
15 = RTD 1000Ω Pt 3916	34 = TC Type S
16 = RTD 120Ω Ni 618	35 = TC Type B
17 = RTD 200Ω Ni 618	36 = TC Type N
18 = RTD 500Ω Ni 618	37 = TC Type C

Rate Alarm

The rate alarm triggers if the rate of change between input samples for **each channel** exceeds the specified trigger point for that channel. It is based on the channels `.RangeType` native units per second. (V, mA, degC (`.TempMode = 0`), degF (`.TempMode = 1`), Ohms.)

For example, if you set the a channel, with a voltage range type, to a rate alarm of 1.0 V/S, the rate alarm will only trigger if the difference between measured input samples changes at a rate > 1.0 V/S. If the module's actual sampling time is 100 ms (i.e. sampling new input data every 100ms) and at time 0, the module measures 5.0 volts and at time 100ms measures 5.08 V, the rate of change is $(5.08V - 5.0V) / (100mS) = 0.8$ V/S. The rate alarm would not set as the change is less than the trigger point of 1.0V/s.

If the next sample taken is 4.9V, the rate of change is $(4.9V - 5.08V) / (100mS) = -1.8$ V/S. The absolute value of this result is > 1.0 V/S, so the rate alarm will set. Absolute value is used because rate alarm checks for the magnitude of the rate of change being beyond the trigger point, whether a positive or negative excursion.

Note: The module acquires data continuously even though it is only reported to the controller at the `.RealTimeSample` rate. The sampling time used for calculating the rate alarm is the acquisition rate. This can be determined by setting the `.RealTimeSample` tag to 10ms (Faster than the module can acquire data) and record the difference between successive `.RollingTimeStamp` values.

.AlarmEnable	0, 1	BOOL
---------------------	------	------

0: Process and rate alarms are disabled
1: Process and rate alarms are enabled.

.ProcessAlarmLatch	0, 1	BOOL
---------------------------	------	------

0: Process alarms are not latched.
1: Process alarms are latched.

.RateAlarmLatch	0, 1	BOOL
------------------------	------	------

0: Rate alarm is not latched.
1: Rate alarm is latched.

.RateAlarmLimit	0 to 4x of native signal value	REAL
------------------------	--------------------------------	------

Specifies a rate alarm will occur if the input data changes more than the configured amount per second between two successive reads either negative or positive. Specified in units (V, mA, Ohms, DegC, DegF) per second.

.LAlarmLimit REAL

A low alarm will activate if the value of the scaled input is at or below this value. It will clear, if not latched, if it is above this level plus the .AlarmDeadband amount.

.HAlarmLimit REAL

A high alarm will activate if the value of the scaled input is at or above this value. It will clear, if not latched, if it is below this level plus the .AlarmDeadband amount.

.LLAlarmLimit REAL

A low-low alarm will activate if the value of the scaled input is at or below this value. It will clear, if not latched, if it is above this level plus the .AlarmDeadband amount.

.HHighAlarmLimit REAL

A high-high alarm will activate if the value of the scaled input is at or above this value. It will clear, if not latched, if it is below this level plus the .AlarmDeadband amount.

.AlarmDeadband REAL

A value used for determining when an alarm condition goes away. See its use in the above alarm tags.

Input Signal Scaling:

With scaling, you change a quantity from one notation to another. When you scale the module, you must choose two points along the module's operating range and apply low and high values to those points. For example, you can cause a 4mA input to display 0% and a 20mA input to display 100%. Scaling causes the module to return data to the controller so that 4mA returns a value of 0% in engineering units and 20mA returns a value of 100% in engineering units.

The module may operate with values beyond the 4mA to 20mA range. If an input signal beyond the low and high signals is present at the module (e.g. 3mA), that data will be represented in terms of the engineering units set during scaling. For example...

Configuration:

```
.RangeType = 6 (0-20mA)
.LowSignal = 4 (4mA)
.HighSignal = 20 (20mA)
.LowEngineering = 0 (0%)
.HighEngineering = 100 (100%)
```

Note: If the signal and engineering range are left at zero, the default range is utilized. Refer to pages 2 and 3 for valid signal and engineering ranges.

Current:	Engineering
	Units value:
3mA	-6.25%
4mA	0%
12mA	50%
20mA	100%
21mA	106.25%

Important: In choosing two points for the low and high signal value of your channel, you do not limit the range of the module.

.LowSignal REAL

When the input is this value it will scale the input to the .LowEngineering value.

.HighSignal REAL

When the input is this value it will scale the input to the .HighEngineering value.

.LowEngineering REAL

The scaled value that will be displayed when the input is at the .LowSignal value.

.HighEngineering REAL

The scaled value that will be displayed when the input is at the .HighSignal value.

Note: User scaling is disabled if .LowSignal is equal to .HighSignal or .LowEngineering is equal to .HighEngineering.

Input Filters:

Module Filter

The universal module uses a ADC filter that provides high frequency noise rejection for the input signals. The ADC filter is programmable, allowing you to select from four filter frequencies for each channel. The filter provides the highest noise rejection at the selected filter frequency.

Selecting a low value (i.e. 10 Hz) for the channel filter frequency provides the best noise rejection for a channel, but it also increases the channel update time. Selecting a high value for the channel filter frequency provides lower noise rejection, but decreases the channel update time.

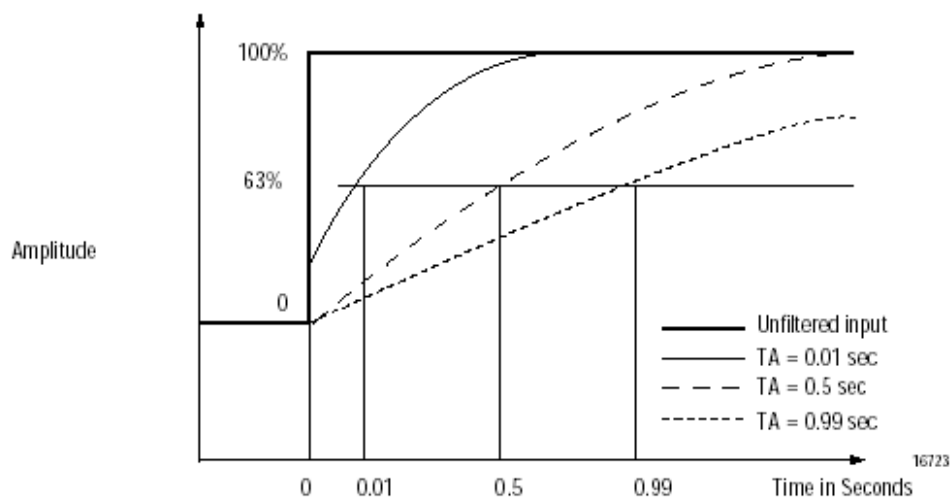

.DigitalFilter

0- 32767 ms

INT

The time constant for a digital first order lag filter applied to the input data for smoothing noise transients. 0 = no digital filter. 100 = data will achieve 63.2% of its value in 100ms.

Input Tags

The following fault and status reporting and module data sections allow monitoring of faults, status, and input data from the module. These tags can be found withing the IF8U_Input controller tag.

Fault and Status Reporting Tags

The 1756-IF8u module multicasts status/fault data to the owner/listening controller with its channel data. The fault data is arranged in such a manner as to allow the user to choose the level of granularity he desires for determining fault conditions.

Three levels of tags work together to provide an increasing degree of detail as to the specific cause of faults on the module. The following tags can be examined in ladder logic to indicate when a fault has occurred:

Channel Fault Word - This word provides underrange, overrange, and communications fault reporting. It's tag name is **.ChannelFaults**.

Module Fault Word - This word provides fault summary reporting. Its tag name is **.ModuleFaults**.

Channel Status Words - These words provide individual channel underrange and overrange fault reporting for process alarms, rate alarms and calibration faults. Its tag name is **.ChannelStatus**.

.ChannelFaults

Bits 0-7, corresponding to channels 0-7 respectively, will be set if the channle is over range or under range.

Any bits set in ChannelFaults sets the ModuleFaults word, InGroupFault and AnalogGroupFault bits.

All bits of the .ChannelFaults tag will be set (16#FFFF) when a communication fault has occured and its owner controller

.Ch0Fault

.Ch1Fault

.Ch2Fault

.Ch3Fault

.Ch4Fault

.Ch5Fault

.Ch6Fault

.Ch7Fault

Ch(x)Fault - Individual channel fault status bit. This indicates an overrange or underrange condition on the channel. These bits are also set by the controller if communications are lost with the I/O module.

.ModuleFaults

Below are a collection of all module level fault bits. Bits are defined as follows:

- 0 - 7 are unused
- 8 - CJOverrange
- 9 - CJUnderrange
- 10 - unused
- 11 - CalFault, set if IF8U_Input.ChannelStatus[x].CalFault bit is set
- 12 - unused
- 13 - unused
- 14 - InGroupFault
- 15 - AnalogGroupFault

Any bit set in the ChannelFaults word sets both the InGroupFault and AnalogGroupFault bits.

.AnalogGroupFault

Indicates if a channel fault has occurred on any channel.

.InGroupFault

Indicates if a channel fault has occurred on any channel.

.CalFault

Status bit indicating if any channel has a bad calibration means that the last attempt to auto calibrate the channel failed with an error and was aborted.

.CJ0Underrange

Status bit to indicate if the Cold junction sensor CJC0 reading is currently beneath the lowest detectable temperature of 0.0 degrees Celsius or open wire.

.CJ0Overrange

Status bit to indicate if the Cold junction sensor CJC0 reading is currently above the highest detectable temperature of 90.0 degrees Celsius or short circuit.

.CJ1Underrange

Status bit to indicate if the Cold junction sensor CJC1 reading is currently beneath the lowest detectable temperature of 0.0 degrees Celsius or open wire.

.CJ1Overrange

Status bit to indicate if the Cold junction sensor CJC1 reading is currently above the highest detectable temperature of 90.0 degrees Celsius or short circuit.

.CJCCalFault

Status bit to indicate if the Cold junction sensor CJC1 or CJC2 calibration failed.

Channel related status tags:

The following channel related tags are preceded by the tag name IF8U_Input.ChannelStatus[X] where X is the channel number 0-7

.Underrange

Indicates the channel's input is equal to or less than the minimum value for the selected range or open wire.

Note: The (-10 to +10vdc) input type does not support this function.

.Ovrange

Indicates the channel's input is equal to or above the maximum value for the selected range.

Note: The (-10 to +10vdc) and (0 to 10vdc) input types do not support this function.

.CalFault

Status bit indicating if the channel has a "Bad" calibration means that the third attempt to autocalibrate the channel failed with an error and was aborted.

.RateAlarm

Alarm bit which gets set when the input channel's rate of change exceeds the configured RateAlarmLimit. Remains set until the rate of change drops below the configured limit unless latched via RateAlarmLatch in the configuration.

.LAlarm

Low alarm bit which is set when the input signal moves beneath the configured low alarm trigger point (LAlarmLimit). Remains set until the input signal moves above the trigger point, unless latched via ProcessAlarmLatch or the input is still within the configured alarm deadband of the low alarm trigger point.

.HAlarm

High alarm bit which is set when the input signal moves above the configured high alarm trigger point(HAlarmLimit). Remains set until the input signal moves below the trigger point, unless latched via ProcessAlarmLatch or the input is still within the configured alarm deadband of the high alarm trigger point.

.LLAlarm

Low low alarm bit which is set when the input signal moves beneath the configured low low alarm trigger point(LLAlarmLimit). Remains set until the input signal moves above the trigger point, unless latched via ProcessAlarmLatch or the input is still within the configured alarm deadband of the low low alarm trigger point.

.HHAlarm

High high alarm bit which is set when the input signal moves above the configured high high alarm trigger point(HHAlarmLimit). Remains set until the input signal moves below the trigger point, unless latched via ProcessAlarmLatch or the input is still within the configured alarm deadband of the high high alarm trigger point.

.Status

Below are a collection of individual channel status bits. Bits are defined as follows:

- 0 – HHAlarm
- 1 – LLAlarm
- 2 – HAlarm
- 3 – Lalarm
- 4 – RateAlarm
- 5 – Overrange
- 6 – Underrange
- 7 – CalFault
- 8 – 15 are unused

Module Data Tags

The following data tags are preceded by the tag name IF8u_Input.ChannelData[x] where x is the channel number 0-7.

.Ch0Data REAL

The channel 0 input signal represented in engineering units. The input signal is measured and then scaled based on the user configuration.

.Ch1Data REAL

The channel 1 input signal represented in engineering units. The input signal is measured and then scaled based on the user configuration.

.Ch2Data REAL

The channel 2 input signal represented in engineering units. The input signal is measured and then scaled based on the user configuration.

.Ch3Data REAL

The channel 3 input signal represented in engineering units. The input signal is measured and then scaled based on the user configuration.

.Ch4Data REAL

The channel 4 input signal represented in engineering units. The input signal is measured and then scaled based on the user configuration.

.Ch5Data REAL

The channel 5 input signal represented in engineering units. The input signal is measured and then scaled based on the user configuration.

.Ch6Data REAL

The channel 6 input signal represented in engineering units. The input signal is measured and then scaled based on the user configuration.

.Ch7Data REAL

The channel 7 input signal represented in engineering units. The input signal is measured and then scaled based on the user configuration.

.CJ0Data REAL

The cold junction sensor temperature of CJC0 in degrees Celsius or Fahrenheit.

.CJ1Data REAL

The cold junction sensor temperature of CJC1 in degrees Celsius or Fahrenheit.

.CSTTimestamp 2 dimension array of DINT

Timestamp taken at time the input data was sampled and placed in terms of Coordinated System Time which is a 64bit quantity in microseconds coordinated across the rack. Must be addressed in 32 bit chunks as an array.

.RollingTimestamp INT

Timestamp taken at time the input data was sampled which is in terms of milliseconds relative solely to the individual module.

Programming Examples

Earlier chapters explained how the tag configuration defines the way the module operates. This chapter shows some basic programming which controls the operation of the module. It also provides you with segments of ladder logic specific to unique situations that might apply to your programming requirements.

Initial Programming

Figure 5.1 illustrates some basic ladder logic commands which will allow you to:

- program the initial configuration into the module
- copy data to user defined tags
- reset the module
- make on-the-fly configuration changes
- unlatch alarms

Additional ladder logic and configuration samples may also be found on our web site: **www.spectrumcontrols.com**.

Figure 5.1 Sample Ladder Logic

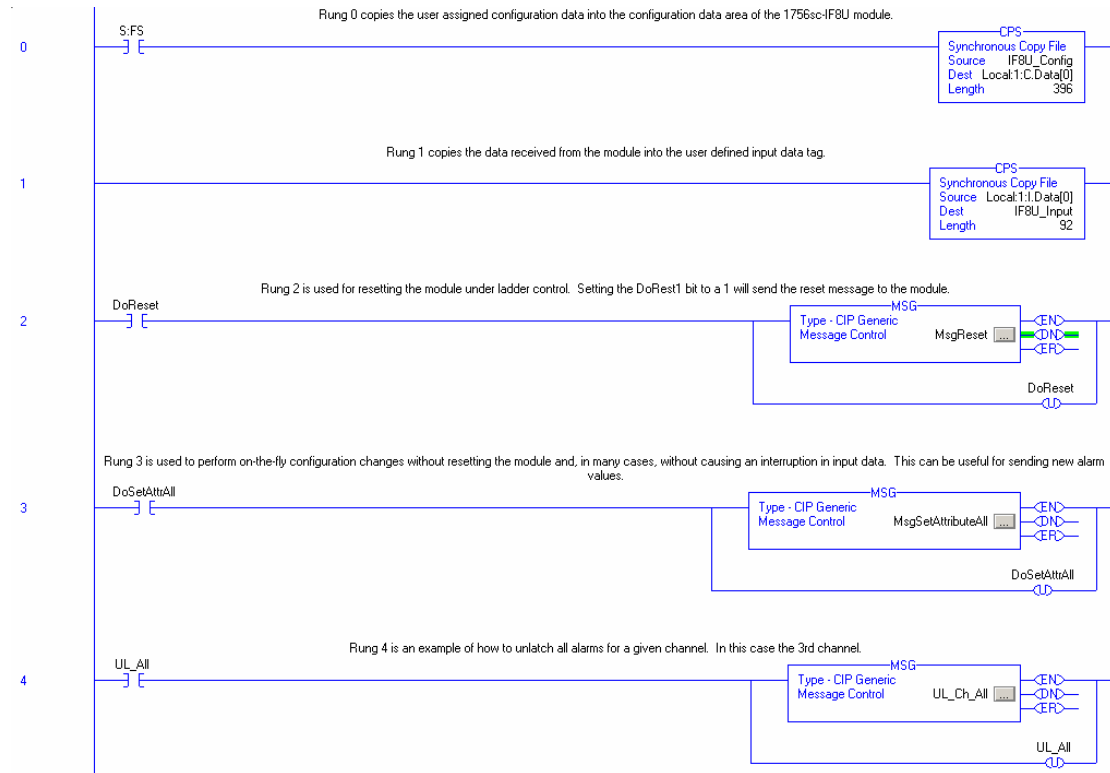

Rung 0 - This rung copies the configuration data (IF8u_Config) into the module's configuration image memory. This rung is required.

Rung 1 - This rung copies the input data received from the module's input memory into the IF8u_Input tag for monitoring and ladder usage. This rung is required.

Rung 2 - This is an optional example rung indicating how to reset the module via ladder logic.

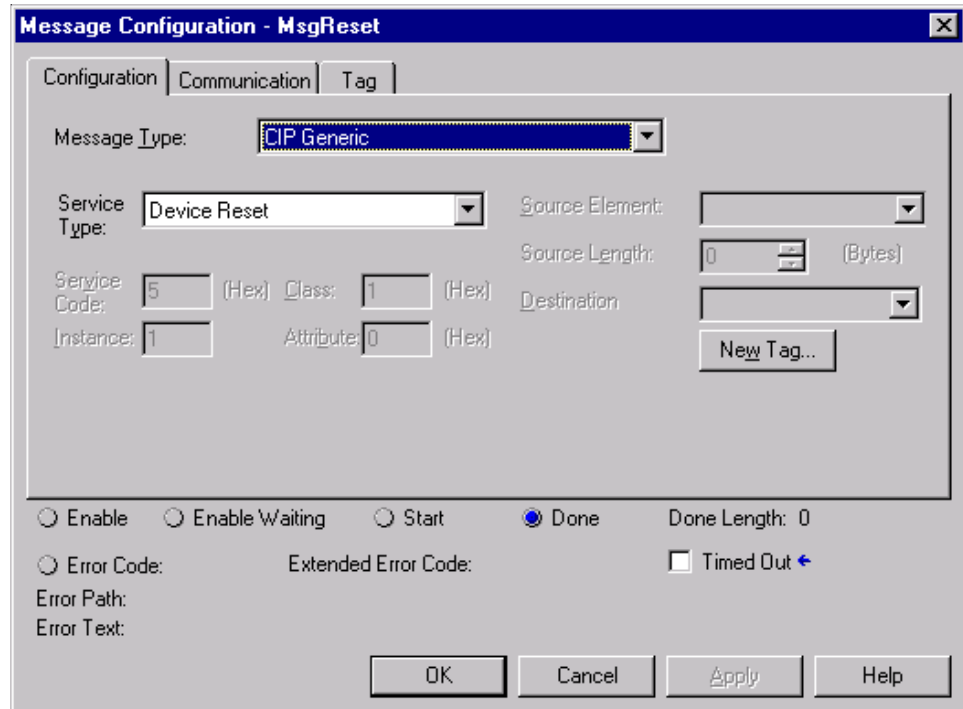

Rung 3 - This is an optional example rung indicating how to send on-the-fly configuration data to the module. This is useful if you would like to change channel alarm or scaling tags without causing interruption in channel updates. Changing other tags will cause a 2.5 second delay in channel updates but the connection will not be interrupted.

Continued on next page...

You may use either the SetAttributeAll or the Module Reconfigure message.

Set Attribute All message:

The screenshot shows the 'Message Configuration - MsgSetAttributeAll' dialog box. It has three tabs: 'Configuration', 'Communication', and 'Tag'. The 'Configuration' tab is active. The 'Message Type' is set to 'CIP Generic'. The 'Service Type' is 'Custom'. The 'Source Element' is 'IF8U_Config'. The 'Source Length' is 396 Bytes. The 'Service Code' is 4c (Hex), 'Class' is 4 (Hex), and 'Instance' is 225. The 'Attribute' is 0 (Hex). There are radio buttons for 'Enable', 'Enable Waiting', 'Start', and 'Done'. The 'Done Length' is 0. There are also radio buttons for 'Error Code', 'Extended Error Code', and 'Timed Out'. The 'Error Path' and 'Error Text' fields are empty. At the bottom, there are buttons for 'OK', 'Cancel', 'Apply', and 'Help'.

Module Reconfigure Message:

The screenshot shows the 'Message Configuration - MsgReconfig' dialog box. It has three tabs: 'Configuration', 'Communication', and 'Tag'. The 'Configuration' tab is active. The 'Message Type' is set to 'Module Reconfigure'. The main area of the dialog contains the text: 'Update module configuration without interrupting the connection.' At the bottom, there are radio buttons for 'Enable', 'Enable Waiting', 'Start', and 'Done'. The 'Done Length' is 0. There are also radio buttons for 'Error Code', 'Extended Error Code', and 'Timed Out'. The 'Error Path' is 'IF8u' and the 'Error Text' is empty. At the bottom, there are buttons for 'OK', 'Cancel', 'Apply', and 'Help'.

Rung 4: This rung describes how to unlatch process alarms.

<u>Service Type</u>	<u>Service Code</u>	<u>Class</u>	<u>Attribute</u>
Unlatch All Alarms (I)	4b	a	0
Unlatch Analog High Alarm (I)	4b	a	6c
Unlatch Analog High High Alarm (I)	4b	a	6e
Unlatch Analog Low Alarm (I)	4b	a	6b
Unlatch Analog Low Low Alarm (I)	4b	a	6d
Unlatch Rate Alarm (I)	4b	a	6f

Channel number + 1.
1=Ch0, 8=Ch7, etc.

Troubleshooting

Using Module Indicators to Troubleshoot

The universal analog I/O module has indicators which provide indication of module status. ControlLogix modules use the following:

LED	This display:	Means	Take this action:
OK	Steady Green Light	The inputs are being multicast	None
OK	Flashing Green Light	The module has passed internal diagnostics but is not currently performing connected communication	None
OK	Flashing Red Light	Previously established communication has timed out and chassis communications	Check controller
OK	Steady Red Light	It is likely the module should be replaced	See below
CAL	Flashing Green Light	The module is in calibration mode	None

Under fault conditions the IF8u will communicate a particular error via a LED blink code. A description of the fault conditions and LED blink codes is listed below...

OK LED	CAL LED	Fault Status
RED	3 Blinks	Major Nonrecoverable EEPROM Fault. Send in Module for Repair
RED	4 Blinks	Major Nonrecoverable Serial Number not programmed. Send in Module for Repair
RED	5 Blinks	Major Nonrecoverable Boot code section has failed the CRC check. Send in Module for Repair
RED	6 Blinks	Major Recoverable Application code section has failed the CRC check. Try re-programming the module firmware. If condition persists send module in for repair.
RED	9 Blinks	Major Nonrecoverable Module has lost it's calibration data. Send in Module for repair.
RED	10 Blinks	Major Recoverable Module's firmware watchdog timer has timed out. Try resetting module. If condition persists send module in for repair.
RED	11 Blinks	Major Nonrecoverable Wrong application installed. Send in Module for Repair.
RED	12 Blinks	Major Recoverable ADC communication fault. Try resetting module. If condition persists send module in for repair.

Note: In RSLogix5000 the Fault Status can be seen in the "Module Info" tab of the module's properties dialog.

The following LED display is used with ControlLogix analog input modules:

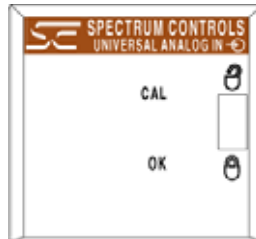

Using RSLogix 5000 to Troubleshoot Your Module

In addition to the LED display on the module, RSLogix 5000 will alert you to fault conditions. You will be alerted in one of three ways:

- Warning signal on the main screen next to the module-This occurs when the connection to the module is broken
- Fault message in a screen's status line · Notification in the Tag Editor - General module faults are also reported in the Tag Editor. Diagnostic faults are only reported in the Tag Editor
- Status on the Module Info Page

The screens below display fault notification in RSLogix 5000.

The screenshot shows the RSLogix 5000 software interface. On the left, a tree view displays the project structure, including folders for Controller IF8u_Sample, Tasks, Motion Groups, Trends, Data Types, and I/O Configuration. Under I/O Configuration, a module is listed as [3] 1756-MODULE IF8u. Below the tree view, the 'Module Defined Tags' section shows two tags: Local:3:C and Local:3:I. At the bottom, a 'Description' table displays the fault message:

Description	Module Fault
	(Code 16#0009) Module Configuration Rejected: Parameter Error. - Additional Fault Code 16#0002

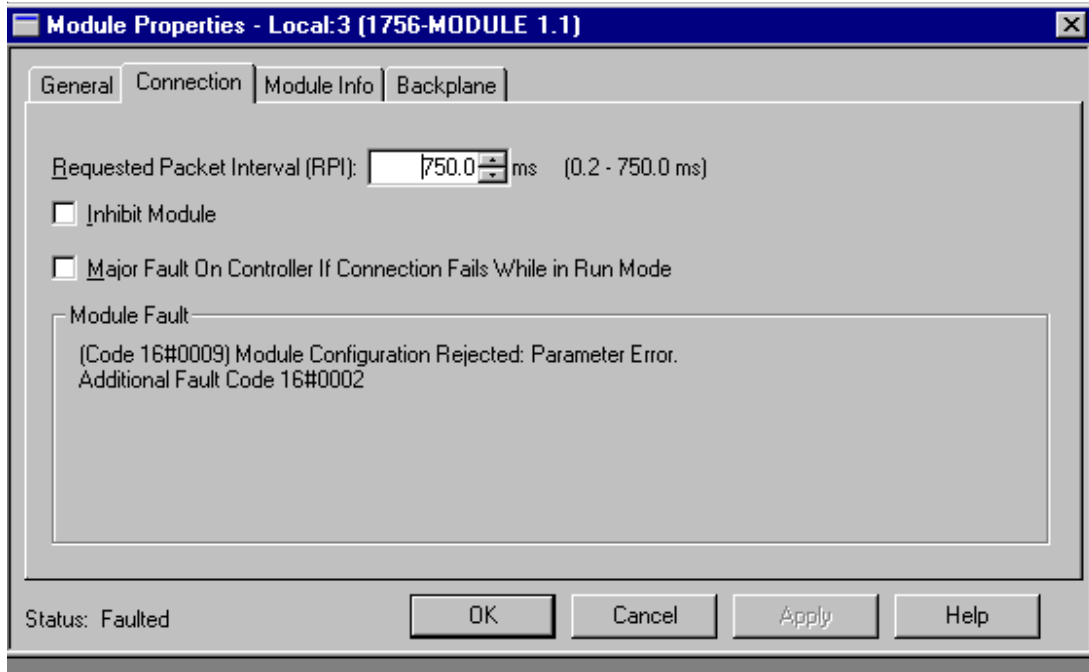

Fault information on the properties screen.

Determining Fault Type

When you are monitoring a module's properties dialog in RSLogix 5000 and receive a fault message, the module fault area lists the type of fault.

Module Configuration Errors

The “Additional Fault Code” value details the configuration error if the “(16#0009) module configuration rejected: Parameter Error” was received.

Global Errors

- 16#0F04 - .ConfigurationRevError
If the .ConfigurationRevNumber tag is 1 and a second owner attempts to connect with a different configuration, this error will occur. You must adjust the second owners configuration to match the first.
- 16#0F05 - .ConfiguratinRevNumber Error
An invalid value has been entered into this tag.
- 16#0F06 - .CyclicalAutocalPeriod Error
An invalid value has been entered into this tag.
- 16#0F07 - .RealTimeSample Error
An invalid value has been entered into this tag.
- 16#0F08 - .CJOffset
An invalid value has been entered into this tag.

Channel Specific Errors

Note: n = channel number (0-7)

- 16#0n01 - .RangeType Error
An invalid value has been entered into this tag.
- 16#0n02 - .ADCFilter Error
An invalid value has been entered into this tag.
- 16#0n03 - .TenOhmOffset Error
An invalid value has been entered into this tag.
- 16#0n04 - .DigitalFilter Error
An invalid value has been entered into this tag.
- 16#0n05 - .RateAlarmLimit Error
An invalid value has been entered into this tag.
- 16#0n06 - .AlarmDeadband Error
An invalid value has been entered into this tag.

Note: If there are multiple errors in the configuration tags only one will be displayed at a time. Once the displayed error has been corrected, the additional errors will be displayed upon reconnection to the module. Each error must be resolved before a running connection will be allowed.

Maintaining Your Module And Ensuring Safety

Read this chapter to familiarize yourself with:

- preventive maintenance
- safety considerations

The National Fire Protection Association (NFPA) recommends maintenance procedures for electrical equipment. Refer to article 70B of the NFPA for general safety-related work practices.

Preventive Maintenance

The printed circuit boards of your module must be protected from dirt, oil, moisture, and other airborne contaminants. To protect these boards, install the ControlLogix system in an enclosure suitable for its operating environment. Keep the interior of the enclosure clean, and whenever possible, keep the enclosure door closed.

Also, regularly inspect the terminal connections for tightness. Loose connections may cause a malfunctioning of the SLC system or damage to the components.



WARNING

POSSIBLE LOOSE CONNECTIONS

Before inspecting connections, always ensure that incoming power is OFF.

Failure to observe this precaution can cause personal injury and equipment damage.

Safety Considerations

Safety is always the most important consideration. Actively think about the safety of yourself and others, as well as the condition of your equipment. The following are some things to consider:

Indicator Lights – When the module status LED on your module is illuminated, your module is receiving power.

Activating Devices When Troubleshooting – Never reach into a machine to activate a device; the machine may move unexpectedly. Use a wooden stick.

Standing Clear Of Machinery – When troubleshooting a problem with any ControlLogix system, have all personnel remain clear of machinery. The problem may be intermittent, and the machine may move unexpectedly. Have someone ready to operate an emergency stop switch.



CAUTION

POSSIBLE EQUIPMENT OPERATION

Never reach into a machine to actuate a switch. Also, remove all electrical power at the main power disconnect switches before checking electrical connections or inputs/outputs causing machine motion.

Failure to observe these precautions can cause personal injury or equipment damage.

Safety Circuits – Circuits installed on machinery for safety reasons (like over-travel limit switches, stop push-buttons, and interlocks) should always be hard-wired to the master control relay. These circuits should also be wired in series so that when any one circuit opens, the master control relay is de-energized, thereby removing power. Never modify these circuits to defeat their function. Serious injury or equipment damage may result.



WARNING

EXPLOSION HAZARD

SUBSTITUTION OF COMPONENTS MAY IMPAIR SUITABILITY FOR CLASS I DIVISION 2.



WARNING

EXPLOSION HAZARD

DO NOT DISCONNECT EQUIPMENT UNLESS POWER HAS BEEN SWITCHED OFF OR THE AREA IS KNOWN TO BE NON-HAZARDOUS

NOTE: THIS EQUIPMENT IS SUITABLE FOR USE IN CLASS I, DIVISION 2, GROUPS A, B, C, AND D OR NON-HAZARDOUS LOCATIONS ONLY.

WARNING



EXPLOSION HAZARD

WHEN IN HAZARDOUS LOCATIONS, TURN OFF
POWER BEFORE REPLACING OR WIRING MODULES.

WARNING



THIS DEVICE IS INTENDED TO ONLY BE USED WITH
THE ALLEN-BRADLEY CONTROLLOGIX 1756 I/O
SYSTEM.

Module Specifications

This appendix lists the specifications for the 1756sc-IF8u Universal analog Input Module.

Electrical Specifications

Backplane Current Consumption	230 mA at 5 VDC 75 mA at 24 VDC
Backplane Power Consumption	3.00W maximum (0.6W @ 5 VDC, 2.4W @ 24 VDC)
Number of Channels	8 (backplane and channel-to-channel isolated)
I/O Chassis Location	Any I/O module slot
A/D Conversion Method	Sigma-Delta Modulation
Input Filtering	Low pass digital filter with programmable notch (filter) frequencies User defined digital filter
Normal Mode Rejection (between [+] input and [-] input)	64.5 dB at 50 Hz, 60 Hz with 10 Hz filter selected
Common Mode Rejection (between inputs and chassis ground)	96 dB at 50 Hz, 60 Hz with 10 Hz filter selected
Input Filter Cut-Off Frequencies	7.8 Hz at 10 Hz filter frequency 39.2 Hz at 50/60 Hz filter frequency 65.54 Hz at 100 Hz filter frequency 163.9 Hz at 250 Hz filter frequency 659.7 Hz at 1000 Hz filter frequency
Calibration	Module autocalibrates at power-up and periodically afterwards*
Input Overvoltage Protection	±14.5 VDC continuous 250W pulsed for 1 msec.
Input Overcurrent Protection	28 mA continuous 40 mA, 1mS pulsed, 10% duty cycle maximum
Isolation	1000 VDC continuous between inputs and chassis ground and between inputs and backplane. 12.5 VDC continuous between channels

* User defineable

Physical Specifications

LED Indicators	1 red/green status indicators, 1 red calibration status
Recommended Cable: for thermocouple inputs... for mV, V or mA inputs for RTD inputs	Shielded twisted pair thermocouple extension wire ❶ Belden 8761 or equivalent shielded Belden #9501, #9533, #83503 ❷
Maximum Wire Size	One 2.1 mm ² (16AWG) wire or two 0.25 mm ² (22AWG) wires per terminal

❶ Refer to the thermocouple manufacturer for the correct extension wire.

❷ Refer to the RTD manufacturer and Chapter 1 of this user's manual.



ATEX Special Conditions for Safe Use

- Provision shall be made to prevent the rated voltage being exceeded by the transient disturbances of more than 140% of the peak rated voltage.
- The system shall be mounted in an ATEX certified enclosure with a minimum ingress protection rating of at least IP54 as defined in IEC60529 or EN60529 and used in an environment of not more than pollution degree 2. The enclosure shall be accessible with the use of a tool.

Environmental Specifications

Operating Temperature	0°C to 60°C (32°F to 140°F)
Storage Temperature	-40°C to 85°C (-40°F to 185°F)
Relative Humidity	5% to 95% (without condensation)
Certification	UL & CUL approved UL 508 2006/95/EC Low Voltage Directive 2004/108/EC Electromagnetic Compatibility 94/9/EC ATEX CE compliance to EN 61010-1, EN 61131-2, EN61000-6-2 EN61000-6-4
Hazardous Environment Classification	Class I Division 2 T5 Hazardous Environment Groups A, B, C, D

Input Specifications

Type of Input (Selectable)	Thermocouple Type J	-210°C to 1200°C	(-346°F to 2192°F)
	Thermocouple Type K	-270°C to 1372°C	(-454°F to 2502°F)
	Thermocouple Type T	-270°C to 400°C	(-454°F to 752°F)
	Thermocouple Type E	-270°C to 1000°C	(-454°F to 1832°F)
	Thermocouple Type R	0°C to 1768°C	(32°F to 3214°F)
	Thermocouple Type S	0°C to 1768°C	(32°F to 3214°F)

Thermocouple Type B	300°C to 1820°C	(572°F to 3308°F)
Thermocouple Type N	-210°C to 1300°C	(-346°F to 2372°F)
Thermocouple Type C	0°C to 2315°C	(32°F to 4199°F)
CJC Sensor	0°C to 90°C	(32°F to 194°F)

Millivolt (-50 mVdc to +50 mVdc / -150 mVdc to +150 mVdc)
 Volt (0-5V, 1-5V, 0-10V, ±10V)

Current (4 to 20mA / 0 to 20mA)

RTD Pt 385 (100Ω, 200Ω, 500Ω, 1000Ω)	-200°C to 850°C	-328°F to 1562°F
RTD Pt 3916 (100Ω, 200Ω, 500Ω, 1000Ω)	-200°C to 630°C	-328°F to 1166°F
RTD 10Ω Cu 426	-100°C to 260°C	-148°F to 500°F
RTD Ni 618 (120Ω, 200Ω, 500Ω, 1000Ω)	-100°C to 260°C	-148°F to 500°F
RTD 120Ω Ni 672	-80°C to 260°C	-112°F to 500°F
RTD 120Ω Ni/Fe 518	-100°C to 200°C	-148°F to 376°F

Resistance (0 to 250/500/1000/2000/3000/4000Ω)

RTD Conversion	JIS C 1602-1997 for Pt 385 JIS C 1604-1989 for Pt 3916 SAMA RC21-4-1966 for the 10 Ω Cu 426 RTD DIN 43760 Sept. 1987 for the 120 Ω Ni 618 RTD MINCO Application Aid #18 May 1990 for the 120 Ω Ni 672 RTD
Thermocouple Linearization	NIST ITS-90 standard
RTD Current Source	252 μ A or 1.008mA, one for each RTD channel
Cold Junction Compensation	2 Onboard CJC Sensor Required
Input Impedence	Greater than 1M Ω > Ohm Voltage / Thermocouple / RTD < 250 Ω current
Temperature Scale (Selectable)	$^{\circ}$ C or $^{\circ}$ F
Open Circuit Detection	via Underrange Does not apply to \pm 10V range
Time to Detect Open Circuit	< 5 Seconds
Input Step Response	0 to 95% in 190 msec (50/60 Hz)
Display Resolution	IEEE Floating Point
Overall Module Accuracy @ 25 $^{\circ}$ C (77 $^{\circ}$ F)	See Module Accuracy Tables below
Overall Module Accuracy (0 $^{\circ}$ C to 60 $^{\circ}$ C, 32 $^{\circ}$ F to 140 $^{\circ}$ F)	See Module Accuracy Tables below
Overall Module Drift	See Module Accuracy Tables below
Module Update Time	Dependent upon enabled channels (see Update Time, Chap 3)
Channel Turn-Off Time	Up to one module update time

Overall Accuracy

The accuracy of the module is determined by many aspects of the hardware and software functionality of the module. The following attempts to explain what the user can expect in terms of accuracy based on the thermocouple, RTD, resistance, and millivolt, volt, and milliamp inputs for the IF8u module.

The accuracies specified as follows include errors due to the cold junction compensation for thermocouples, current source errors for RTDs, and hardware and software errors associated with the system, which depends upon input path. RTD accuracies do not include errors due to lead

resistance imbalance. The hardware and software errors include calibration of the system, and non-linearity of the ADC. For the sake of the calculations the resolution of the ADC was assumed to be at least 16 bits (use of the 10Hz, 50Hz, and 60Hz filter frequencies). Note: The 250Hz frequency should not be applied to thermocouple or RTD inputs if accuracy is a concern.

Input Type	Error @ 25C typical & worst case	Error over temp typical & worst case
Platinum 385 100 ohm	0.05% FS, 0.1% FS	0.1% FS, 0.25% FS
Platinum 385 200 ohm	0.05% FS, 0.1% FS	0.1% FS, 0.25% FS
Platinum 385 500 ohm	0.05% FS, 0.1% FS	0.1% FS, 0.25% FS
Platinum 385 1000 ohm	0.05% FS, 0.1% FS	0.1% FS, 0.25% FS
Platinum 3916 100 ohm	0.05% FS, 0.1% FS	0.1% FS, 0.25% FS
Platinum 3916 200 ohm	0.05% FS, 0.1% FS	0.1% FS, 0.25% FS
Platinum 3916 500 ohm	0.05% FS, 0.1% FS	0.1% FS, 0.25% FS
Platinum 3916 1000 ohm	0.05% FS, 0.1% FS	0.1% FS, 0.25% FS
Nickel 618 120 ohm	0.05% FS, 0.1% FS	0.1% FS, 0.25% FS
Nickel 618 200 ohm	0.05% FS, 0.1% FS	0.1% FS, 0.25% FS
Nickel 618 500 ohm	0.05% FS, 0.1% FS	0.1% FS, 0.25% FS
Nickel 618 1000 ohm	0.05% FS, 0.1% FS	0.1% FS, 0.25% FS
Nickel 672 120 ohm	0.05% FS, 0.1% FS	0.1% FS, 0.25% FS
Nickel-Fe 518 604 ohm	0.05% FS, 0.1% FS	0.1% FS, 0.25% FS
Cu 427 10 ohm	0.5% FS, 1.0% FS	1.0% FS, 2.0% FS
Resistance Input, 0-250 ohms	0.05% FS, 0.1% FS	0.25% FS, 0.5% FS
Resistance Input, 0-500 ohms	0.05% FS, 0.1% FS	0.1% FS, 0.25% FS
Resistance Input, 0-1000 ohms	0.05% FS, 0.1% FS	0.1% FS, 0.25% FS
Resistance Input, 0-2000 ohms	0.05% FS, 0.1% FS	0.1% FS, 0.25% FS
Resistance Input, 0-3000 ohms	0.05% FS, 0.1% FS	0.1% FS, 0.25% FS
Resistance Input, 0-4000 ohms	0.05% FS, 0.1% FS	0.1% FS, 0.25% FS
Input Type	Error @ 25C typical & worst case	Error over temp typical & worst case
Type J, -210 to 1200C	0.05% FS, 0.1% FS	0.1% FS, 0.25% FS
Type K, -225 to 1370C	0.05% FS, 0.1% FS	0.1% FS, 0.25% FS
Type K, -270 to -225C	0.3% FS, 0.6% FS	0.6% FS, 1.2% FS
Type T, -230 to 400C	0.05% FS, 0.1% FS	0.25% FS, 0.5% FS
Type T, -270 to -230C	0.5% FS, 1.25% FS	1.25% FS, 2.5% FS
Type E, -220 to 1000C	0.05% FS, 0.1% FS	0.1% FS, 0.25% FS
Type E, -270 to -220C	0.25% FS, 0.5% FS	0.5% FS, 1.0% FS
Type R, 0 to 1768C	0.06% FS, 0.12% FS	0.12% FS, 0.25% FS
Type S, 0 to 1768C	0.06% FS, 0.12% FS	0.12% FS, 0.25% FS
Type B, 600 to 1820C	0.09% FS, 0.18% FS	0.25% FS, 0.5% FS
Type B, 300 to 600C	0.11% FS, 0.22% FS	0.5% FS, 1.0% FS
Type N, -200 to 1300C	0.05% FS, 0.1% FS	0.1% FS, 0.25% FS
Type N, -210 to 200C	0.07% FS, 0.14% FS	0.14% FS, 0.28% FS
Type C, 0 to 2315C	0.05% FS, 0.1% FS	0.1% FS, 0.25% FS

Current Input, 0 to 20mA	0.05% FS, 0.1% FS	0.1% FS, 0.25% FS
Current Input, 4 to 20mA	0.05% FS, 0.1% FS	0.1% FS, 0.25% FS
Voltage Input, -10 to +10V	0.025% FS, 0.05% FS	0.05% FS, 0.1% FS
Voltage Input, 0 to 10V	0.025% FS, 0.05% FS	0.05% FS, 0.1% FS
Voltage Input, 0 to 5 V	0.025% FS, 0.05% FS	0.05% FS, 0.1% FS
Voltage Input, 1 to 5V	0.025% FS, 0.05% FS	0.05% FS, 0.1% FS
Voltage Input, -50m to +50mV	0.05% FS, 0.1% FS	0.1% FS, 0.2% FS
Voltage Input, -150m to +150mV	0.05% FS, 0.1% FS	0.1% FS, 0.2% FS

Thermocouple Descriptions

The following information was extracted from the NIST Monograph 175 issued in January 1990, which supersedes the IPTS-68 Monograph 125 issued in March 1974. NIST Monograph 175 is provided by the United States Department of Commerce, National Institute of Standards and Technology.

International Temperature Scale of 1990

The ITS-90 [1,3] is realized, maintained and disseminated by NIST to provide a standard scale of temperature for use in science and industry in the United States. This scale was adopted by the International Committee of Weights and Measures (CIPM) at its meeting in September 1989, and it became the official international temperature scale on January 1, 1990. The ITS-90 supersedes the IPTS-68(75) [2] and the 1976 Provisional 0.5 °K to 30 °K Temperature Scale (EPT-76) [4].

The adoption of the ITS-90 has removed several deficiencies and limitations associated with IPTS-68. Temperatures on the ITS-90 are in closer agreement with thermodynamic values than were those of the IPTS-68 and EPT-76. Additionally, improvements have been made in the non-uniqueness and reproducibility of the temperature scale, especially in the temperature range from $t_{68} = 630.74^{\circ}\text{C}$ to 1064.43°C , where the type S thermocouple was the standard interpolating device on the IPTS-68.

For additional technical information regarding ITS-90, refer to the NIST Monograph 175.

J Type Thermocouples

Iron Versus Copper-Nickel Alloy (SAMA) Thermocouples

This is one of the most common types of industrial thermocouples, because of its relatively high Seebeck coefficient and low cost. It has been reported that more than 200 tons of type J materials are supplied annually to industry in this country. However, this type is least suitable for accurate thermometry because there are significant nonlinear deviations in the thermoelectric output of thermocouples obtained from different manufacturers. These irregular deviations lead to difficulties in obtaining accurate calibrations based on a limited number of calibration points. The positive thermoelement is commercially pure (99.5% Fe) iron, usually containing significant impurity levels of carbon, chromium, copper, manganese, nickel, phosphorus, silicon, and sulfur. Thermocouple wire represents such a small fraction of the total production of commercial iron wire that the producers do not control the chemical composition to maintain constant thermoelectric properties. Instead, instrument companies and thermocouple fabricators select material most suitable for

the thermocouple usage. The total and specific types of impurities that occur in commercial iron change with time, location of primary ores, and methods of smelting. Many unusual lots have been selected in the past, for example spools of industrial iron wire and even scrapped rails from an elevated train line. At present, iron wire that most closely fits these tables has about 0.25 percent manganese and 0.12 percent copper, plus other minor impurities.

The negative thermoelement for type J thermocouples is a copper-nickel alloy known ambiguously as constantan. The word constantan has commonly referred to copper-nickel alloys containing anywhere from 45 to 60 percent copper, plus minor impurities of carbon, cobalt, iron, and manganese. Constantan for type J thermocouples usually contains about 55 percent copper, 45 percent nickel, and a small but thermoelectrically significant amount of cobalt, iron, and manganese, about 0.1 percent or more. **It should be emphasized that type JN thermoelements are NOT generally interchangeable with type TN (or EN) thermoelements, although they are all referred to as “constantan”.** In order to provide some differentiation in nomenclature, type JN is often referred to as SAMA constantan.

Type J thermocouples are recommended by the ASTM [5] for use in the temperature range from 0°C to 760°C in vacuum, oxidizing, reducing, or inert atmospheres. If used for extended times in air above 500°C, heavy gage wires are recommended because the oxidation rate is rapid at elevated temperatures. Oxidation normally causes a gradual decrease in the thermoelectric voltage of the thermocouple with time. Because iron rusts in moist atmospheres and may become brittle, type J thermocouples are not recommended for use below 0°C. In addition, they should not be used unprotected in sulfurous atmospheres above 500°C.

The positive thermoelement, iron, is relatively insensitive to composition changes under thermal neutron irradiation, but does exhibit a slight increase in manganese content. The negative thermoelement, a copper-nickel alloy, is subject to substantial composition changes under thermal neutron irradiation since copper is converted to nickel and zinc.

Iron undergoes a magnetic transformation near 769°C and an alpha-gamma crystal transformation near 910°C [6]. Both of these transformations, especially the latter, seriously affect the thermoelectric properties of iron, and therefore of type J thermocouples. This behavior and the rapid oxidation rate of iron are the main reasons why iron versus constantan thermocouples are not recommended as a standardized type above 760°C. If type J thermocouples are taken to high temperatures, especially above 900°C, they will lose the accuracy of their calibration when they are recycled to lower temperatures. If type J thermocouples are used in air at temperatures above 760°C, only the largest wire, AWG 8 (3.3mm) should be used and they should be held at the measured temperature for 10 to 20 minutes before readings are taken. The thermoelectric voltage of the type J thermocouples may change by as

much as 40 μ V (or 0.6°C equivalent) per minute when first brought up to temperatures near 900°C.

ASTM Standard E230-87 in the 1992 Annual Book of ASTM Standards [7] specifies that the initial calibration tolerances for type J commercial thermocouples be $\pm 2.2^\circ\text{C}$ or $\pm 0.75\%$ (whichever is greater) between 0°C and 750°C. Type J thermocouples can also be supplied to meet special tolerances, which are equal to approximately one-half the standard tolerances given above. Tolerances are not specified for type J thermocouples below 0°C or above 750°C.

The suggested upper temperature limit of 760°C given in the above ASTM standard [7] for protected type J thermocouples applies to AWG 8 (3.25mm) wire. For smaller diameter wires the suggested upper temperature limit decreases to 590°C for AWG 14 (1.63mm), 480°C for AWG 20 (0.81mm), 370°C for AWG 24 or 28 (0.51mm or 0.33mm), and 320°C for AWG 30 (0.25mm). These temperature limits apply to thermocouples used in conventional closed-end protecting tubes and they are intended only as a rough guide to the user. They do not apply to sheathed thermocouples having compacted mineral oxide insulation.

K Type Thermocouples

Nickel-Chromium Alloy Versus Nickel-Aluminum Alloy Thermocouples

This type is more resistant to oxidation at elevated temperatures than types E, J, or T thermocouples and, consequently, it finds wide application at temperatures above 500°C. The positive thermoelement, KP, which is the same as EP, is an alloy that typically contains about 89 to 90% nickel, 9 to about 9.5% chromium, both silicon and iron in amounts up to about 0.5%, plus smaller amounts of other constituents such as carbon, manganese, cobalt, and niobium. The negative thermoelement, KN, is typically composed of about 95 to 96% nickel, 1 to 1.5% silicon, 1 to 2.3% aluminum, 1.6 to 3.2% manganese, up to about 0.5% cobalt and smaller amounts of other constituents such as iron, copper, and lead. Also, type KN thermoelements with modified compositions are available for use in special applications. These include alloys in which the manganese and aluminum contents are reduced or eliminated, while the silicon and cobalt contents are increased.

The low temperature research [8] by members of the NBS Cryogenics Division showed that the type K thermocouple may be used down to liquid helium temperatures (about 4°K) but that its Seebeck coefficient becomes quite small below 20°K. Its Seebeck coefficient at 20°K is only about 4 μ V/°K, being roughly one-half that of the type E thermocouple which is the most suitable of the letter-designated thermocouples types for measurements down to 20°K. Type KP and type KN thermoelements do have a relatively low thermal conductivity and good resistance to corrosion in moist atmospheres at low temperatures. The thermoelectric

homogeneity of type KN thermoelements, however, was found [8] to be not quite as good as that of type EN thermoelements.

Type K thermocouples are recommended by the ASTM [5] for use at temperatures within the range -250°C to 1260°C in oxidizing or inert atmospheres. Both the KP and the KN thermoelements are subject to deterioration by oxidation when used in air above about 750°C , but even so, type K thermocouples may be used at temperatures up to about 1350°C for short periods with only small changes in calibration. When oxidation occurs it normally leads to a gradual increase in the thermoelectric voltage with time. The magnitude of the change in the thermoelectric voltage and the physical life of the thermocouple will depend upon such factors as the temperature, the time at temperature, the diameter of the thermoelements and the conditions of use.

The ASTM Manual [5] indicates that type K thermocouples should not be used at high temperatures in sulfurous, reducing, or alternately oxidizing and reducing atmospheres unless suitably protected with protecting tubes. They also should not be used in vacuum (at high temperatures) for extended times because the chromium in the positive thermoelement, a nickel-chromium alloy, vaporizes out of solution and alters the calibration. In addition, their use in atmospheres that promote “green-rot” corrosion [9] of the positive thermoelement should be avoided. Such corrosion results from the preferential oxidation of chromium in atmospheres with low, but not negligible, oxygen content and can lead to a large decrease in the thermoelectric voltage of the thermocouple with time. The effect is most serious at temperatures between 800°C and 1050°C .

Both thermoelements of type K thermocouples are reasonably stable, thermoelectrically, under neutron irradiation since the resulting changes in their chemical compositions due to transmutation are small. The KN thermoelements are somewhat less stable than the KP thermoelements in that they experience a small increase in the iron content accompanied by a slight decrease in the manganese and cobalt contents.

ASTM Standard E230-87 in the 1992 Annual Book of ASTM Standards [7] specifies that the initial calibration tolerances for type K commercial thermocouples be $\pm 2.2^{\circ}\text{C}$ or $\pm 0.75\%$ (whichever is greater) between 0°C and 1250°C , and $\pm 2.2^{\circ}\text{C}$ or $\pm 2\%$ (whichever is greater) between -200°C and 0°C . In the 0°C to 1250°C range, type K thermocouples can be supplied to meet special tolerances that are equal to approximately one-half the standard tolerances given above. Type K thermocouple materials are normally supplied to meet the tolerances specified for temperatures above 0°C . However, the same materials may not satisfy the tolerances specified for the -200°C to 0°C range. If materials are required to meet the tolerances below 0°C , this should be specified when they are purchased.

The suggested upper temperature limit of 1260°C given in the ASTM standard [7] for protected type K thermocouples applies to AWG 8

(3.25mm) wire. It decreases to 1090°C for AWG 14 (1.63mm), 980°C for AWG 20 (0.81mm), 870 for AWG 24 or 28 (0.51mm or 0.33mm), and 760°C for AWG 30 (0.25mm). These temperature limits apply to thermocouples used in conventional closed-end protecting tubes and they are intended only as a rough guide to the user. They do not apply to thermocouples having compacted mineral oxide insulation.

T Type Thermocouples

Copper Versus Copper-Nickel Alloy Thermocouples

This type is one of the oldest and most popular thermocouples for determining temperatures within the range from about 370°C down to the triple point of neon (-248.5939°C). Its positive thermoelement, TP, is typically copper of high electrical conductivity and low oxygen content that conforms to ASTM Specification B3 for soft or annealed bare copper wire. Such material is about 99.95% pure copper with an oxygen content varying from 0.02 to 0.07% (depending upon sulfur content) and with other impurities totaling about 0.01%. Above about -200°C the thermoelectric properties of type TP thermoelements, which satisfy the above conditions, are exceptionally uniform and exhibit little variation between lots. Below about -200°C the thermoelectric properties are affected more strongly by the presence of dilute transition metal solutes, particularly iron.

The negative thermoelement, TN or EN, is a copper-nickel alloy known ambiguously as constantan. The word constantan refers to a family of copper-nickel alloys containing anywhere from 45 to 60% copper. These alloys also typically contain small percentages of cobalt, manganese and iron, as well as trace impurities of other elements such as carbon, magnesium, silicon, etc. The constantan for type T thermocouples usually contains about 55% copper, 45% nickel, and small but thermoelectrically significant amounts, about 0.1% or larger, of cobalt, iron, or manganese. **It should be emphasized that type TN (or EN) thermoelements are NOT generally interchangeable with type JN thermoelements although they are all referred to as “constantan”.** In order to provide some differentiation in nomenclature, type TN (or EN) is often referred to as Adams' (or RP1080) constantan and type JN is usually referred to as SAMA constantan.

The thermoelectric relations for type TN and type EN thermoelements are the same, that is the voltage versus temperature equations and tables for platinum versus type TN thermoelements apply to both types of thermoelements over the temperature range recommended for each thermocouple type. However, it should not be assumed that type TN and type EN thermoelements may be used interchangeably or that they have the same commercial initial calibration tolerances.

The low temperature research [8] by members of the NBS Cryogenics Division showed that the type T thermocouple may be used down to liquid

helium temperatures (about 4°K) but that its Seebeck coefficient becomes quite small below 20°K. Its Seebeck coefficient at 20°K is only about 5.6 μ V/°K, being roughly two-thirds that of the type E thermocouple. The thermoelectric homogeneity of most type TP and type TN (or EN) thermoelements is reasonably good. There is considerable variability, however, in the thermoelectric properties of type TP thermoelements below about 70°K caused by variations in the amounts and types of impurities present in these nearly pure materials. The high thermal conductivity of the type TP thermoelements can also be troublesome in precise applications. For these reasons, type T thermocouples are generally unsuitable for use below about 20°K. Type E thermocouples are recommended as the most suitable of the letter-designated thermocouple types for general low-temperature use, since they offer the best overall combination of desirable properties.

Type T thermocouples are recommended by the ASTM [5] for use in the temperature range from -200°C to 370°C in vacuum or in oxidizing, reducing or inert atmospheres. The suggested upper temperature limit for continuous service of protected type T thermocouples is set at 370°C for AWG 14 (1.63mm) thermoelements since type TP thermoelements oxidize rapidly above this temperature. However, the thermoelectric properties of type TP thermoelements are apparently not grossly affected by oxidation since negligible changes in the thermoelectric voltage were observed at NBS [10] for AWG 12, 18, and 22 type TP thermoelements during 30 hours of heating in air at 500°C. At this temperature the type TN thermoelements have good resistance to oxidation and exhibit only small voltage changes heated in air for long periods of time, as shown by the studies of Dahl [11]. Higher operating temperatures, up to at least 800°C, are possible in inert atmospheres where the deterioration of the type TP thermoelement is no longer a problem. The use of type T thermocouples in hydrogen atmospheres at temperatures above about 370°C is not recommended since type TP thermoelements may become brittle.

Type T thermocouples are not well suited for use in nuclear environments since both thermoelements are subject to significant changes in composition under thermal neutron irradiation. The copper in the thermoelements is converted to nickel and zinc.

Because of the high thermal conductivity of type TP thermoelements, special care should be exercised when using the thermocouples to ensure that the measuring and reference junctions assume the desired temperatures.

ASTM Standard E230-87 in the 1992 Annual Book of ASTM Standards [7] specifies that the initial calibration tolerances for type T commercial thermocouples be $\pm 1^\circ\text{C}$ or $\pm 0.75\%$ (whichever is greater) between 0°C and 350°C, and $\pm 1^\circ\text{C}$ or $\pm 1.5\%$ (whichever is greater) between -200°C and 0°C. Type T thermocouples can also be supplied to meet special tolerances which are equal to approximately one-half the standard tolerances given above. Type T thermocouple materials are normally

supplied to meet the tolerances specified for temperatures above 0°C. However, the same materials may not satisfy the tolerances specified for the -200°C to 0°C range. If materials are required to meet the tolerances below 0°C, this should be specified when they are purchased.

The suggested upper temperature limit of 370°C given in the ASTM standard [7] for protected type T thermocouples applies to AWG 14 (1.63mm) wire. It decreases to 260°C for AWG 20 (0.81mm), 200°C for AWG 24 or 28 (0.51mm or 0.33mm), and 150°C for AWG 30 (0.25mm). These temperature limits apply to thermocouples used in conventional closed-end protecting tubes and they are intended only as a rough guide to the user. They do not apply to thermocouples having compacted mineral oxide insulation.

E Type Thermocouples

Nickel-Chromium Alloy Versus Copper-Nickel Alloy Thermocouples

This type, and the other base-metal types, do not have specific chemical compositions given in standards; rather, any materials whose emf-temperature relationship agrees with that of the specified reference table within certain tolerances can be considered to be a type E thermocouple. The positive thermoelement, EP, is the same material as KP. The negative thermoelement, EN, is the same material as TN.

The low-temperature research [8] by members of the NBS Cryogenics Division showed that type E thermocouples are very useful down to liquid hydrogen temperatures (n.b.p. about 20.3°K) where their Seebeck coefficient is about 8 μ V/°C. They may even be used down to liquid helium temperatures (4.2°K) although their Seebeck coefficient becomes quite low, only about 2 μ V/°C at 4°K. Both thermoelements of type E thermocouples have a relatively low thermal conductivity, good resistance to corrosion in moist atmospheres, and reasonably good homogeneity. For these three reasons and their relatively high Seebeck coefficients, type E thermocouples have been recommended [8] as the most useful of the letter-designated thermocouple types for low-temperature measurements.

For measurements below 20°K, the non-letter-designated thermocouple, KP versus gold-0.07 at .% iron, is recommended. The properties of this thermocouple have been described by Sparks and Powell [12].

Type E thermocouples also have the largest Seebeck coefficient above 0°C for any of the letter-designated thermocouples. For that reason they are being used more often whenever environmental conditions permit.

Type E thermocouples are recommended by the ASTM [5] for use in the temperature range from -200°C to 900°C in oxidizing or inert atmospheres. If used for extended times in air above 500°C, heavy gage wires are recommended because the oxidation rate is rapid at elevated temperatures. About 50 years ago, Dahl [11] studies the thermoelectric

stability of EP and EN type alloys when heated in air at elevated temperatures and his work should be consulted for details. More recent stability data on these alloys in air were reported by Burley et al. [13]. Type E thermocouples should not be used at high temperatures in sulfurous, reducing, or alternately reducing and oxidizing atmospheres unless suitably protected with protecting tubes. They also should not be used in vacuum (at high temperatures) for extended times because the chromium in the positive thermoelement, a nickel-chromium alloy, vaporizes out of solution and alters the calibration. In addition, their use in atmospheres that promote “green-rot” corrosion of the positive thermoelement should be avoided. Such corrosion results from the preferential oxidation of chromium in atmospheres with low, but not negligible, oxygen content and can lead to a large decrease in the thermoelectric voltage of the thermocouple with time. The effect is most serious at temperatures between 800°C and 1050°C.

The negative thermoelement, a copper-nickel alloy, is subject to composition changes under thermal neutron irradiation since the copper is converted to nickel and zinc.

Neither thermoelement of type E thermocouples is very sensitive to minor changes in composition or impurity level because both are already heavily alloyed. Similarly, they are also not extremely sensitive to minor differences in heat treatment (provided that the treatment does not violate any of the restrictions mentioned above). For most general applications, they may be used with the heat treatment given by the wire manufacturers. However, when the highest accuracy is sought, additional preparatory heat treatments may be desirable in order to enhance their performance. Details on this and other phases of the use and behavior of type KP thermoelements (EP is the same as KP) are given in publications by Pots and McElroy [14], by Burley and Ackland [15], by Burley [16], by Wang and Starr [17,18], by Bentley [19], and by Kollie et al. [20].

ASTM Standard E230-87 in the 1992 Annual Book of ASTM Standards [7] specifies that the initial calibration tolerances for type E commercial thermocouples be $\pm 1.7^{\circ}\text{C}$ or $\pm 0.5\%$ (whichever is greater) between 0°C and 900°C, and $\pm 1.7^{\circ}\text{C}$ or $\pm 1\%$ (whichever is greater) between -200°C and 0°C. Type E thermocouples can also be supplied to meet special tolerances which are equal to $\pm 1^{\circ}\text{C}$ or $\pm 0.4\%$ (whichever is greater) between 0°C and 900°C, and $\pm 1^{\circ}\text{C}$ or $\pm 0.5\%$ (whichever is greater) between -200°C and 0°C. Type E thermocouple materials are normally supplied to meet the tolerances specified for temperatures above 0°C. The same materials, however, may not satisfy the tolerances specified for the -200°C to 0°C range. If materials are required to meet the tolerances below 0°C, this should be specified when they are purchased.

The suggested upper temperature limit, 870°C, given in the ASTM standard [7] for protected type E thermocouples applies to AWG 8 (3.25mm) wire. It decreases to 650°C for AWG 14 (1.63mm), 540°C for

AWG 20 (0.81mm), 430°C for AWG 24 or 28 (0.51mm or 0.33mm), and 370°C for AWG 30 (0.25mm). These temperature limits apply to thermocouples used in conventional closed-end protecting tubes and they are intended only as a rough guide to the user. They do not apply to thermocouples having compacted mineral oxide insulation.

R Type Thermocouples

Platinum-13% Rhodium Alloy Versus Platinum Thermocouples

This type is often referred to by the nominal chemical composition of its positive (RP) thermoelement: platinum-13% rhodium. The negative (RN) thermoelement is commercially-available platinum that has a nominal purity of 99.99% [21]. An industrial consensus standard (ASTM E1159-87) specifies that rhodium having a nominal purity of 99.98% shall be alloyed with platinum of 99.99% purity to produce the positive thermoelement, which typically contains 13.00 +/-0.05% rhodium by weight. This consensus standard [21] describes the purity of commercial type R materials that are used in many industrial thermometry applications and that meet the calibration tolerances described later in this section. It **does not** cover, however, the higher-purity, reference-grade materials that traditionally were used to construct thermocouples used as transfer standards and reference thermometers in various laboratory applications and to develop reference functions and tables [22,23]. The higher purity alloy material typically contains less than 500 atomic ppm of impurities and the platinum less than 100 atomic ppm of impurities [22]. Differences between such high purity commercial material and the platinum thermoelectric reference standard, Pt-67, are described in [22] and [23].

A reference function for the type R thermocouple, based on the ITS-90 and the SI volt, was determined recently from new data obtained in a collaborative effort by NIST and NPL. The results of this international collaboration were reported by Burns et al [23]. The function was used to compute the reference table given in this monograph.

Type R thermocouples have about a 12% larger Seebeck coefficient than do Type S thermocouples over much of the range. Type R thermocouples were not standard interpolating instruments on the IPTS-68 for the 630.74°C to gold freezing-point range. Other than these two points, and remarks regarding history and composition, all of the precautions and restrictions on usage given in the section on type S thermocouples also apply to type R thermocouples. Glawe and Szaniszlo [24], and Walker et al [25,26] have determined the effects that prolonged exposure at elevated temperatures (>1200°C) in vacuum, air, and argon atmospheres have on the thermoelectric voltages of type R thermocouples.

ASTM Standard E230-87 in the 1992 Annual Book of ASTM Standards [7] specifies that the initial calibration tolerances for type R commercial thermocouples be +/-1.5°C or +/-0.25% (whichever is greater) between

0°C and 1450°C. Type R thermocouples can be supplied to meet special tolerances of $\pm 0.6^\circ\text{C}$ or $\pm 0.1\%$ (whichever is greater).

The suggested upper temperature limit, 1480°C, given in the ASTM standard [7] for protected type R thermocouples applies to AWG 24 (0.51 mm) wire. This temperature limit applies to thermocouples used in conventional closed-end protecting tubes and it is intended only as a rough guide to the user. It does not apply to thermocouples having compacted mineral oxide insulation.

S Type Thermocouples

Platinum-10% Rhodium Alloy Versus Platinum Thermocouples

This type is often referred to by the nominal chemical composition of its positive (SP) thermoelement: platinum-10% rhodium. The negative (SN) thermoelement is commercially available platinum that has a nominal purity of 99.99% [21]. An industrial consensus standard (ASTM E1159-87) specifies that rhodium having a nominal purity of 99.98% shall be alloyed with platinum of 99.99% purity to produce the positive thermoelement, which typically contains 10.00 \pm 0.05% rhodium by weight. The consensus standard [21] describes the purity of commercial type S materials that are used in many industrial thermometry applications and that meet the calibration tolerances described later in this section. It **does not** cover, however, the higher-purity, reference-grade materials that traditionally were used to construct thermocouples used as standard instruments of the IPTS-68, as transfer standards and reference thermometers in various laboratory applications, and to develop reference functions and tables [27,28]. The higher purity alloy material typically contains less than 500 atomic ppm of impurities and the platinum less than 100 atomic ppm of impurities [27]. Difference between such high purity commercial material and the platinum thermoelectric reference standard, Pt-67, are described in [27] and [28].

A reference function for the type S thermocouple, based on the ITS-90 and the SI volt, was determined recently from new data obtained in an international collaborative effort involving eight national laboratories. The results of this international collaboration were reported by Burns et al. [28]. The new function was used to compute the reference table given in this monograph.

Research [27] demonstrated that type S thermocouples can be used from -50°C to the platinum melting-point temperature. They may be used intermittently at temperatures up to the platinum melting point and continuously up to about 1300°C with only small changes in their calibrations. The ultimate useful life of the thermocouples when used at such elevated temperatures is governed primarily by physical problems of impurity diffusion and grain growth, which lead to mechanical failure. The thermocouple is most reliable when used in a clean oxidizing atmosphere (air) but may be used also in inert gaseous atmospheres or in a vacuum for

short periods of time. However, type B thermocouples are generally more suitable for such applications above 1200°C. Type S thermocouples should not be used in reducing atmospheres, nor in those containing metallic vapor (such as lead or zinc), nonmetallic vapors (such as arsenic, phosphorus, or sulfur) or easily reduced oxides, unless they are suitably protected with nonmetallic protecting tubes. Also, they should never be inserted directly into a metallic protection tube for use at high temperatures. The stability of type S thermocouples at high temperatures (>1200°C) depends primarily upon the quality of the materials used for protection and insulation, and has been studied by Walker et al. [25,26] and by Bentley [29]. High purity alumina, with low iron content, appears to be the most suitable material for insulating, protecting, and mechanically supporting the thermocouple wires.

Both thermoelements of type S thermocouples are sensitive to impurity contamination. In fact, type R thermocouples were developed essentially because of iron contamination effects in some British platinum-10% rhodium wires. The effects of various impurities on the thermoelectric voltages of platinum based thermocouple materials have been described by Rhys and Taimsalu [35], by Cochrane [36] and by Aliotta [37]. Impurity contamination usually causes negative changes [25,26,29] in the thermoelectric voltage of the thermocouple with time, the extent of which will depend upon the type and amount of chemical contaminant. Such changes were shown to be due mainly to the platinum thermoelement [25,26,29]. Volatilization of the rhodium from the positive thermoelement for the vapor transport of rhodium from the positive thermoelement to the pure platinum negative thermoelement also will cause negative drifts in the thermoelectric voltage. Bentley [29] demonstrated that the vapor transport of rhodium can be virtually eliminated at 1700°C by using a single length of twin-bore tubing to insulate the thermoelements and that contamination of the thermocouple by impurities transferred from the alumina insulator can be reduced by heat treating the insulator prior to its use.

McLaren and Murdock [30-33] and Bentley and Jones [34] thoroughly studied the performance of type S thermocouples in the range 0°C to 1100°C. They described how thermally reversible effects, such as quenched-in point defects, mechanical stresses, and preferential oxidation of rhodium in the type SP thermoelement, cause chemical and physical inhomogeneities in the thermocouple and thereby limit its accuracy in this range. They emphasized the importance of annealing techniques.

The positive thermoelement is unstable in a thermal neutron flux because the rhodium converts to palladium. The negative thermoelement is relatively stable to neutron transmutation. Fast neutron bombardment, however, will cause physical damage, which will change the thermoelectric voltage unless it is annealed out.

At the gold freezing-point temperature, 1064.18°C, the thermoelectric voltage of type S thermocouples increases by about 340µV (about 3%) per

weight percent increase in rhodium content; the Seebeck coefficient increases by about 4% per weight percent increase at the same temperature.

ASTM Standard E230-87 in the 1992 Annual Book of ASTM Standards [7] specifies that the initial calibration tolerances for type S commercial thermocouples be $\pm 1.5^{\circ}\text{C}$ or $\pm 0.25\%$ (whichever is greater) between 0°C and 1450°C . Type S thermocouples can be supplied to meet special tolerances of $\pm 0.6^{\circ}\text{C}$ or $\pm 0.1\%$ (whichever is greater).

The suggested upper temperature limit, 1480°C , given in the ASTM standard [7] for protected type S thermocouples applies to AWG 24 (0.51 mm) wire. This temperature limit applies to thermocouples used in conventional closed-end protecting tubes and it is intended only as a rough guide to the user. It does not apply to thermocouples having compacted mineral oxide insulation.

B Type Thermocouples

Platinum-30% Rhodium Alloy Versus Platinum-6% Rhodium Alloy Thermocouples

This type is sometimes referred to by the nominal chemical composition of its thermoelements: platinum - 30% rhodium versus platinum - 6% rhodium or “30-6”. The positive (BP) thermoelement typically contains $29.60 \pm 0.2\%$ rhodium and the negative (BN) thermoelement usually contains $6.12 \pm 0.02\%$ rhodium. The effect of differences in rhodium content are described later in this section. An industrial consensus standard [21] (ASTM E1159-87) specifies that rhodium having a purity of 99.98% shall be alloyed with platinum of 99.99% purity to produce the thermoelements. This consensus standard [21] describes the purity of commercial type B materials that are used in many industrial thermometry applications that meet the calibration tolerances described later in this section. Both thermoelements will typically have significant impurities of elements such as palladium, iridium, iron, and silicon [38].

Studies by Ehringer [39], Walker et al. [25,26], and Glawe and Szaniszló [24] have demonstrated that thermocouples, in which both legs are platinum-rhodium alloys, are suitable for reliable temperature measurements at high temperatures. Such thermocouples have been shown to offer the following distinct advantages over types R and S thermocouples at high temperatures: (1) improved stability, (2) increased mechanical strength, and (3) higher operating temperatures.

The research by Burns and Gallagher [38] indicated that the 30-6 thermocouple can be used intermittently (for several hours) up to 1790°C and continuously (for several hundred hours) at temperatures up to about 1700°C with only small changes in calibration. The maximum temperature limit for the thermocouple is governed, primarily, by the melting point of the Pt-6% rhodium thermoelement which is estimated to be about 1820°C by Acken [40]. The thermocouple is most reliable when used in a clean

oxidizing atmosphere (air) but also has been used successfully in neutral atmospheres or vacuum by Walker et al [25,26], Hendricks and McElroy [41], and Glawe and Szaniszlo [24]. The stability of the thermocouple at high temperatures has been shown by Walker et al. [25,26] to depend, primarily, on the quality of the materials used for protecting and insulating the thermocouple. High purity alumina with low iron-content appears to be the most suitable material for the purpose.

Type B thermocouples should not be used in reducing atmospheres, nor those containing deleterious vapors or other contaminants that are reactive with the platinum group metals [42], unless suitably protected with nonmetallic protecting tubes. They should never be used in metallic protecting tubes at high temperatures.

The Seebeck coefficient of type B thermocouples decreases with decreasing temperature below about 1600°C and becomes almost negligible at room temperature. Consequently, in most applications the reference junction temperature of the thermocouple does not need to be controlled or even known, as long as it is between 0°C and 50°C. For example, the voltage developed by the thermocouple, with the reference junction at 0°C, undergoes a reversal in sign at about 42°C, and between 0°C and 50°C varies from a minimum of -2.6uV near 21°C to a maximum of 2.3uV at 50°C. Therefore, in use, if the reference junction of the thermocouple is within the range 0°C to 50°C, then a 0°C reference junction temperature can be assumed and the error introduced will not exceed 3uV. At temperatures above 1100°C, an additional measurement error of 3uV (about 0.3°C) would be insignificant in most instances.

ASTM Standard E230-87 in the 1992 Annual Book of ASTM Standards [7] specifies that the initial calibration tolerances for type B commercial thermocouples be +/-0.5% between 870°C and 1700°C. Type B thermocouples can also be supplied to meet special tolerances of +/- 0.25%. Tolerances are not specified for type B thermocouples below 870°C.

The suggested upper temperature limit of 1700°C given in the ASTM standard [7] for protected type B thermocouples applies to AWG 24 (0.51mm) wire. This temperature limit applies to thermocouples used in conventional closed-end protecting tubes and it is intended only as a rough guide to the user. It does not apply to thermocouples having compacted mineral oxide insulation.

N Type Thermocouples

Nickel-Chromium-Silicon Alloy Versus Nickel-Silicon-Magnesium Alloy Thermocouples

This type is the newest of the letter-designated thermocouples. It offers higher thermoelectric stability in air above 1000°C and better air-oxidation resistance than types E, J, and K thermocouples. The positive thermoelement, NP, is an alloy that typically contains about 84% nickel, 14

to 14.4% chromium, 1.3 to 1.6% silicon, plus small amounts (usually not exceeding about 0.1%) of other elements such as magnesium, iron, carbon, and cobalt. The negative thermoelement, NN, is an alloy that typically contains about 95% nickel, 4.2 to 4.6% silicon, 0.5 to 1.5% magnesium, plus minor impurities of iron, cobalt, manganese and carbon totaling about 0.1 to 0.3%. The type NP and NN alloys were known originally [16] as nicosil and nisil, respectively.

The research reported in NBS Monograph 161 showed that the type N thermocouple may be used down to liquid helium temperatures (about 4°K) but that its Seebeck coefficient becomes very small below 20°K. Its Seebeck coefficient at 20°K is about 2.5 μ V/°K, roughly one-third that of type E thermocouples which are the most suitable of the letter-designated thermocouples types for measurements down to 20°K. Nevertheless, types NP and NN thermoelements do have a relatively low thermal conductivity and good resistance to corrosion in moist atmospheres at low temperatures.

Type N thermocouples are best suited for use in oxidizing or inert atmospheres. Their suggested upper temperature limit, when used in conventional closed-end protecting tubes, is set at 1260°C by the ASTM [7] for 3.25mm diameter thermoelements. Their maximum upper temperature limit is defined by the melting temperature of the thermoelements, which are nominally 1410°C for type NP and 1340°C for type NN [5]. The thermoelectric stability and physical life of type N thermocouples when used in air at elevated temperatures will depend upon factors such as the temperature, the time at temperature, the diameter of the thermoelements, and the conditions of use. Their thermoelectric stability and oxidation resistance in air have been investigated and compared with those of type K thermocouples by Burley [16], by Burley and others [13,44-47], by Wang and Starr [17,43,48,49], by McLaren and Murdock [33], by Bentley [19], and by Hess [50].

Type N thermocouples, in general, are subject to the same environmental restrictions as types E and K. They are not recommended for use at high temperatures in sulfurous, reducing, or alternately oxidizing and reducing atmospheres unless suitably protected with protecting tubes. They also should not be used in vacuum (at high temperatures) for extended times because the chromium and silicon in the positive thermoelement, a nickel-chromium-silicon alloy, vaporize out of solution and alter the calibration. In addition, their use in atmospheres with low, but not negligible, oxygen content is not recommended, since it can lead to changes in calibration due to the preferential oxidation of chromium in the positive thermoelement. Nevertheless, Wang and Starr [49] studied the performances of type N thermocouples in reducing atmospheres, as well as in stagnant air, at temperatures in the 870°C to 1180°C range and found them to be markedly more stable thermoelectrically than type K thermocouples under similar conditions.

The performance of type N thermocouples fabricated in metal-sheathed, compacted ceramic insulated form also has been the subject of considerable study. Anderson and others [51], Bentley and Morgan [52], and Wang and Bediones [53] have evaluated the high-temperature, thermoelectric stability of thermocouples insulated with magnesium oxide and sheathed in Inconel and in stainless steel. Their studies showed that the thermoelectric instabilities of such assemblies increase rapidly with temperature above 1000°C. It was found also that the smaller the diameter of the sheath the greater the instability. Additionally, thermocouples sheathed in Inconel showed substantially less instability above 1000°C than those sheathed in stainless steel. Bentley and Morgan [52] stressed the importance of using Inconel sheathing with a very low manganese content to achieve the most stable performance. The use of special Ni-Cr based alloys for sheathing to improve the chemical and physical compatibility with the thermoelements also has been investigated by Burley [54-56] and by Bentley [57-60].

Neither thermoelement of a type N thermocouple is extremely sensitive to minor differences in heat treatment (provided that the treatment does not violate any of the restrictions mentioned above). For most general applications, they may be used with the heat treatment routinely given by the wire manufacturer. Bentley [61,62], however, has reported reversible changes in the Seebeck coefficient of type NP and NN thermoelements when heated at temperatures between 200°C and 1000°C. These impose limitations on the accuracy obtainable with type N thermocouples. The magnitude of such changes was found to depend on the source of the thermoelements. Consequently, when the highest accuracy and stability are sought, selective testing of materials, as well as special preparatory heat treatments beyond those given by the manufacturer, will usually be necessary. Bentley's articles [61,62] should be consulted for guidelines and details.

ASTM Standard E230-87 in the 1992 Annual Book of ASTM Standards [7] specifies that the initial calibration tolerances for type N commercial thermocouples be $\pm 2.2^\circ\text{C}$ or $\pm 0.75\%$ (whichever is greater) between 0°C and 1250°C. Type N thermocouples can also be supplied to meet special tolerances that are equal to approximately one-half the standard tolerances given above. Tolerances are not specified for type N thermocouples below 0°C.

The suggested upper temperature limit of 1260°C given in the ASTM standard [7] for protected type N thermocouples applies to AWG 8 (3.25mm) wire. It decreases to 1090°C for AWG 14 (1.63mm), 980°C for AWG 20 (0.81mm), 870°C for AWG 24 or 28 (0.51mm or 0.33mm), and 760°C for AWG 30 (0.25mm). These temperature limits apply to thermocouples used in conventional closed-end protecting tubes and they are intended only as a rough guide to the user. They do not apply to thermocouples having compacted mineral oxide insulation.

References

- [1] Preston-Thomas, H. The International Temperature Scale of 1990 (ITS-90). *Metrologia* **27**, 3-10; 1990. *ibid.* p. 107.
- [2] The International Practical Temperature Scale of 1968, Amended Edition of 1975. *Metrologia* **12**, 7-17, 1976.
- [3] Mangum, B. W.; Furukawa, G. T. Guidelines for realizing the International Temperature Scale of 1990 (ITS-90). *Natl. Inst. Stand. Technol. Tech. Note 1265*; 1990 August. 190 p.
- [4] The 1976 Provisional 0.5 to 30 K Temperature Scale. *Metrologia* **15**, 65-68; 1979.
- [5] ASTM, American Society for Testing and Materials. Manual on the use of thermocouples in temperature measurement. *Special Tech. Publ. 470B*; edited by Benedict, R. P.; Philadelphia: ASTM; 1981. 258p.
- [6] Hansen, M.; Anderko, K. Constitution of binary alloys. New York: McGraw-Hill Book Co.; 1958.
- [7] ASTM, American Society for Testing and Materials, Standard E230-87, *1992 Annual Book of ASTM Standards*. Vol. **14.03**; Philadelphia: ASTM; 1992. 102-230.
- [8] Sparks, L. L.; Powell, R. L.; Hall, W. J. Reference tables for low-temperature thermocouples. *Natl. Bur. Stand. (U.S.) Monogr. 124*; 1972 June. 61p.
- [9] Starr, C.D.; Wang, T. P. Effect of oxidation on stability of thermocouples, *Proceedings of the American Society for Testing and Materials* Vol. **63**, 1185-1194; 1963.
- [10] Roeser, W. F.; Dahl, A. I. Reference tables for iron-constantan and copper-constantan thermocouples. *J. Res. Natl. Bur. Stand. (U.S.)* **20**, 337-355; RP1080; 1938 March.
- [11] Dahl, A. I. Stability of base-metal thermocouples in air from 800 to 2200F. *J. Res. Natl. Bur. Stand. (U.S.)* **24**, 205-224; RP1278; 1940 February.
- [12] Sparks, L. L.; Powell, R. L. Low temperatures thermocouples: KP, "normal" silver, and copper versus Au-0.02 at % Fe and Au-0.07 at % Fe. *J. Res. Natl. Bur. Stand. (U.S.)* **76A(3)**, 263-283; 1972 May-June.
- [13] Burley, N. A.; Hess, R. M.; Howie, C. F.; Coleman, J. A. The nicrosil versus nisil thermocouple: A critical comparison with the ANSI standard letter-designated base-metal thermocouples. *Temperature: Its Measurement and Control in Science and Industry*; Vol. 5, Schooley, J. F., ed.; New York: American Institute of Physics; 1982. 1159-1166.

- [14] Potts, J. F. Jr.; McElroy, D. L. The effects of cold working, heat treatment, and oxidation on the thermal emf of nickel-base thermoelements. Herzfeld, C. M.; Brickwedde, F. G.; Dahl, A. I.; Hardy, J. D., ed. *Temperature: Its Measurement and Control in Science and Industry*; Vol. 3, Part 2; New York: Reinhold Publishing Corp.; 1962. 243-264.
- [15] Burley, N. A.; Ackland, R. G. The stability of the thermo-emf/temperature characteristics of nickel-base thermocouples. *Jour. of Australian Inst. of Metals* **12(1)**, 23-31; 1967.
- [16] Burley, N. A. Nicrosil and nisil: Highly stable nickel-base alloys for thermocouples. *Temperature: Its Measurement and Control in Science and Industry*; Vol. 4, Plumb, H. H., ed.; Pittsburgh: Instrument Society of America; 1972. 1677-1695.
- [17] Wang, T. P.; Starr, C. D. Electromotive force stability of nicrosil-nisil. *Journal of Testing and Evaluation* **8(4)**, 192-198; 1980.
- [18] Starr, C. D.; Wang, T. P. Effect of oxidation on stability of thermocouples, *Proceedings of the American Society for Testing and Materials* Vol. **63** 1185-1194; 1963.
- [19] Bentley, R. E. Short-term instabilities in thermocouples containing nickel-based alloys. *High Temperatures- High Pressures* **15**, 599-611; 1983.
- [20] Kollie, T. G.; Horton, J. L.; Carr, K. R.; Herskovitz, M. B.; Mossman, C. A. Temperature measurement errors with type K (Chromel vs. Alumel) thermocouples due to short-ranged ordering in Chromel. *Rev. Sci. Instrum.* **46**, 1447-1461; 1975.
- [21] ASTM, American Society for Testing and Materials, Standard E1159-87, *1992 Annual Book of ASTM Standards*. Vol. **14.03**; Philadelphia: ASTM; 1992. 388-389.
- [22] Bedford, R. E.; Ma, C. K.; Barber, C. R.; Chandler, T. R.; Quinn, T. J.; Burns, G. W.; Scroger, M. New reference tables for platinum 10% rhodium/platinum and platinum 13% rhodium/platinum thermocouples. *Temperature: Its Measurement and Control in Science and Industry*; Vol. 4, Part 3, p. 1585; Plumb, H. H., ed.; Pittsburgh: Instrument Society of America; 1972.
- [23] Burns, G. W.; Strouse, G. F.; Mangum, B. W.; Croarkin, M. C.; Guthrie, W. F.; Chattle, M. New reference functions for platinum-13% rhodium versus platinum (type R) and platinum-30% rhodium versus platinum-6% rhodium (type B) thermocouples based on the ITS-90. in *Temperature: Its Measurement and Control in Science and Industry*; Vol. 6; Schooley, J. F., ed.; New York: American Institute of Physics; 1992. 559-564.

- [24] Glawe, G. E.; Szaniszlo, A. J. Long-term drift of some noble- and refractory-metal thermocouples at 1600K in air, argon, and vacuum. *Temperature: Its Measurement and Control in Science and Industry*; Vol. 4; Plumb, H. H., ed.; Pittsburgh: Instrument Society of America; 1972. 1645-1662.
- [25] Walker, B. E.; Ewing, C. T.; Miller, R. R. Thermoelectric instability of some noble metal thermocouples at high temperatures. *Rev. Sci. Instrum.* **33**, 1029-1040; 1962.
- [26] Walker, B. E.; Ewing, C. T.; Miller, R. R. Study of the instability of noble metal thermocouples in vacuum. *Rev. Sci. Instrum.* **36**, 601-606; 1965.
- [27] Bedford, R. E.; Ma, C. K.; Barber, C. R.; Chandler, T. R.; Quinn, T. J.; Burns, G. W.; Scroger, M. New reference tables for platinum 10% rhodium/platinum and platinum 13% rhodium/platinum thermocouples. *Temperature: Its Measurement and Control in Science and Industry*; Vol. 4; Plumb, H. H., ed.; Pittsburgh: Instrument Society of America; 1972. 1585-1603.
- [28] Burns, G. W.; Strouse, G. F.; Mangum, B. W.; Croarkin, M. C.; Guthrie, W. F.; Marcarino, P.; Battuello, M.; Lee, H. K.; Kim, J. C.; Gam, K. S.; Rhee, C.; Chattle, M.; Arai, M.; Sakurai, H.; Pokhodun, A. I.; Moiseeva, N. P.; Perevalova, S. A.; de Groot, M. J.; Zhang, J.; Fan, K.; Wu, S. New reference functions for platinum-10% rhodium versus platinum (type S) thermocouples based on the ITS-90, Part I and Part II. in *Temperature: Its Measurement and Control in Science and Industry*; Vol. 6; Schooley, J. F., ed.; New York: American Institute of Physics; 1992. 537-546.
- [29] Bentley, R. E. Changes in Seebeck coefficient of Pt and Pt 10% Rh after use to 1700C in high-purity polycrystalline alumina. *Int. J. Thermophys.* **6(1)**, 83-99; 1985.
- [30] McLaren, E. H.; Murdock, E. G. New considerations on the preparation, properties and limitations of the standard thermocouple for thermometry. *Temperature: Its Measurement and Control in Science and Industry*; Vol. 4; Plumb, H. H., ed.; Pittsburgh: Instrument Society of America; 1972. 1543-1560.
- [31] McLaren, E. H.; Murdock, E. G. The properties of Pt/PtRh thermocouples for thermometry in the range 0-1100C: I. Basic measurements with standard thermocouples. *National Research Council of Canada Publication APH 2212/NRCC 17407*; 1979.
- [32] McLaren, E. H.; Murdock, E. G. The properties of Pt/PtRh thermocouples for thermometry in the range 0-1100C: II. Effect of heat treatment on standard thermocouples. *National Research Council of Canada Publication APH 2213/NRCC 17408*; 1979.

- [33] McLaren, E. H.; Murdock, E. G. Properties of some noble and base metal thermocouples at fixed points in the range 0-1100C. *Temperature: Its Measurement and Control in Science and Industry*; Vol. 5; Schooley, J. F., ed.; New York: American Institute of Physics; 1982. 953-975.
- [34] Bentley, R. E.; Jones, T. P. Inhomogeneities in type S thermocouples when used to 1064C. *High Temperatures- High Pressures* **12**, 33-45; 1980.
- [35] Rhys, D. W.; Taimsalu, P. Effect of alloying additions on the thermoelectric properties of platinum. *Engelhard Tech. Bull.* **10**, 41-47; 1969.
- [36] Cochrane, J. Relationship of chemical composition to the electrical properties of platinum. *Engelhard Tech. Bull.* **11**, 58-71; 1969. Also in *Temperature: Its Measurement and Control in Science and Industry*; Vol. 4; Plumb, H. H., ed.; Pittsburgh: Instrument Society of America; 1972. 1619-1632.
- [37] Aliotta, J. Effects of impurities on the thermoelectric properties of platinum. *Inst. and Control Systems*, 106-107; March 1972.
- [38] Burns, G. W.; Gallagher, J. S. Reference tables for the Pt-30 percent Rh versus Pt-6 percent Rh thermocouple. *J. Res. Natl. Bur. Stand. (U.S.)* **70C**, 89-125; 1966.
- [39] Ehringer, H. Uber die lebensdauer von PtRh-thermoelementen. *Metall* **8**, 596-598; 1954.
- [40] Acken, J. S. Some properties of platinum-rhodium alloys. *J. Res. Natl. Bur. Stand. (U.S.)* **12**, 249; RP650; 1934.
- [41] Hendricks, J. W.; McElroy, D. L. High temperature- high vacuum thermocouple drift tests. *Environmental Quarterly*, 34-38; March 1967.
- [42] Zysk, E. D. Platinum metal thermocouples. *Temperature: Its Measurement and Control in Science and Industry*; Vol. 3; Herzfeld, C. M., ed.; New York: Reinhold Publishing Corp.; 1962. Part 2, pp. 135-156.
- [43] Starr, C. D.; Wang, T. P. A new stable nickel-base thermocouple. *Journal of Testing and Evaluation* **4(1)**, 42-56; 1976.
- [44] Burley, N. A.; Powell, R. L.; Burns, G. W.; Scroger, M. G. The nicrosil versus nisol thermocouple: properties and thermoelectric reference data. *Natl. Bur. Stand. (U.S.) Monogr.* **161**; 1978 April. 167p.
- [45] Burley, N. A.; Jones, T. P. Practical performance of nicrosil-nisol thermocouples. *Temperature Measurement, 1975*; Billing, B. F.; Quinn, T. J., ed.; London and Bristol: Institute of Physics; 1975. 172-180.

- [46] Burley, N. A.; Hess, R. M.; Howie, C. F. Nicrosil and nisil: new nickel-based thermocouple alloys of ultra-high thermoelectric stability. *High Temperatures- High Pressures* **12**, 403-410; 1980.
- [47] Burley, N. A.; Cocking, J. L.; Burns, G. W.; Scroger, M. G. The nicrosil versus nisil thermocouple: the influence of magnesium on the thermoelectric stability and oxidation resistance of the alloys. *Temperature: Its Measurement and Control in Science and Industry*; Vol. 5, Schooley, J. F., ed.; New York: American Institute of Physics; 1982. 1129-1145.
- [48] Wang, T. P.; Starr, C. D. Nicrosil-nisil thermocouples in production furnaces in the 538C (1000F) to 1177C (2150F) range. *ISA Transactions* **18(4)**, 83-99; 1979.
- [49] Wang, T. P.; Starr, C. D. Oxidation resistance and stability of nicrosil-nisil in air and in reducing atmospheres. *Temperature: Its Measurement and Control in Science and Industry*; Vol. 5, Schooley, J. F., ed.; New York: American Institute of Physics; 1982. 1147-1157.
- [50] Hess, T. G. Nicrosil-nisil: high-performance thermocouple alloys. *ISA Transactions* **16(3)**, 81-84; 1977.
- [51] Anderson, R. L.; Lyons, J. D.; Kollie, T. G.; Christie, W. H.; Eby, R. Decalibration of sheathed thermocouples. *Temperature: Its Measurement and Control in Science and Industry*; Vol. 5., Schooley, J. F., ed.; New York: American Institute of Physics; 1982. 977-1007.
- [52] Bentley, R. E.; Morgan, T. L. Ni-based thermocouples in the mineral-insulated metal-sheathed format: thermoelectric instabilities to 1100C. *J. Phys. E: Sci. Instrum.* **19**, 262-268; 1986.
- [53] Wang, T. P.; Bediones, D. 10,000 hr. stability test of types K, N, and a Ni-Mo/Ni-Co thermocouple in air and short-term tests in reducing atmospheres. *Temperature: Its Measurement and Control in Science and Industry*; Vol. 6; Schooley, J. F., ed.; New York: American Institute of Physics; 1992. 595-600.
- [54] Burley, N. A. N-CLAD-N: A novel advanced type N integrally-sheathed thermocouple of ultra-high thermoelectric stability. *High Temperatures- High Pressures* **8**, 609-616; 1986.
- [55] Burley, N. A. A novel advanced type N integrally-sheathed thermocouple of ultra-high thermoelectric stability. *Thermal and Temperature Measurement in Science and Industry*; 3rd Int. IMEKO Conf.; Sheffield; Sept. 1987. 115-125.
- [56] Burley, N. A. 'N-CLAD-N' A novel integrally sheathed thermocouple: optimum design rationale for ultra-high thermoelectric stability. *Temperature: Its Measurement and Control in Science and Industry*; Vol. 6; Schooley, J. F., ed.; New York: American Institute of Physics; 1992. 579-584.

- [57] Bentley, R. E. The new nicosil-sheathed type N MIMS thermocouple: an assessment of the first production batch. *Mater. Australas.* **18(6)**, 16-18; 1986.
- [58] Bentley, R. E.; Russell, Nicosil sheathed mineral-insulated type N thermocouple probes for short-term variable-immersion applications to 1100C. *Sensors and Actuators* **16**, 89-100; 1989.
- [59] Bentley, R. E. Irreversible thermoelectric changes in type K and type N thermocouple alloys within nicosil-sheathed MIMS cable. *J. Phys. D.* **22**, 1908-1915; 1989.
- [60] Bentley, R. E. Thermoelectric behavior of Ni-based ID-MIMS thermocouples using the nicosil-plus sheathing alloy. *Temperature: Its Measurement and Control in Science and Industry*; Vol. 6; Schooley, J. F., ed.; New York: American Institute of Physics; 1992. 585-590.
- [61] Bentley, R. E. Thermoelectric hysteresis in nicosil and nilsil. *J. Phys. E: Sci. Instrum.* **20**, 1368-1373; 1987.
- [62] Bentley, R. E. Thermoelectric hysteresis in nickel-based thermocouple alloys. *J. Phys. D.* **22**, 1902-1907; 1989.

Using Grounded Junction, Ungrounded Junction, and Exposed Junction Thermocouples

This appendix describes the types of thermocouples available, and explains the trade-offs in using them with the IF8u module.

Thermocouple Types

There are three (3) types of thermocouple junctions:

- **Grounded Junction** - The measuring junction is physically connected to the protective sheath forming a completely sealed integral junction. If the sheath is metal (or electrically conductive) then there is electrical continuity between the junction and sheath. The junction is protected from corrosive or erosive conditions. The response time approaches that of the exposed junction type.
- **Ungrounded Junction** - The measuring junction is electrically isolated from the protective metal sheath. This may also be referred to as an insulated junction. This type is often used where noise would affect the reading and for frequent or rapid temperature cycling. The response time is longer than the grounded junction.
- **Exposed Junction** - The measuring junction does not have a protective metal sheath so it is exposed. This junction style provides the fastest response time but leaves the thermocouple wires unprotected against corrosive or mechanical damage.

The illustration that follows shows each of the three (3) thermocouple types.

Grounded Junction

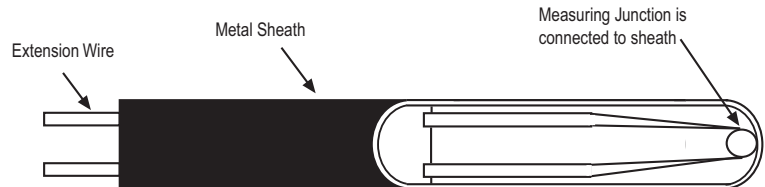

Ungrounded (Insulated) Junction

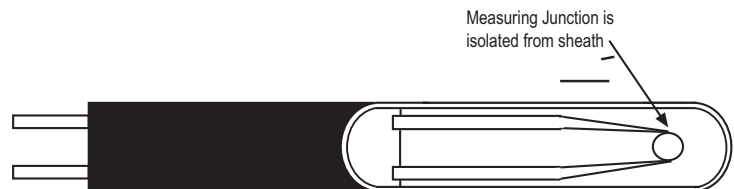

Exposed Junction

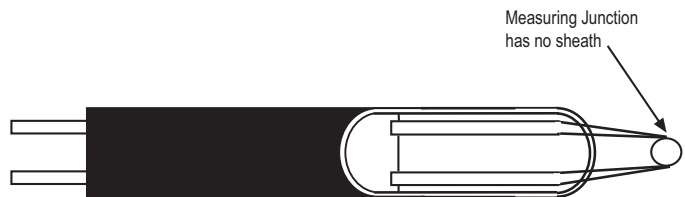

Isolation

The IF8u module provides 12.5 VDC electrical isolation channel to channel, 500 VDC electrical isolation channel to chassis ground, and 500 VDC electrical isolation channel to backplane. Care must be taken when choosing a thermocouple type, and connecting it from the environment being measured to the IF8u module. If adequate precautions are not taken for a given thermocouple type, the electrical isolation of the IF8u module may be compromised.

Grounded Junction Thermocouples

As shown in the illustration that follows, the shield input terminals are connected together, which are then connected to chassis ground. Using grounded junction thermocouples with electrically conductive sheaths, removes the thermocouple signal to chassis ground isolation of the module. This is inherent to the thermocouple construction. In addition, if multiple grounded junction thermocouples are used, the module's channel to channel isolation is removed since there is no isolation between signal and sheath, and the sheaths are tied together. It should be noted that the isolation is removed even if the sheaths are connected to chassis ground at a location other than the module, since the module is connected to chassis ground.

For grounded junction thermocouples it is recommended that they have protective sheaths made of electrically insulated material (e.g. ceramic), or the metal protective sheaths be floated. The metal sheaths would need to be floated with respect to any path to chassis ground or to another thermocouple metal sheath. This means the metal sheath must be insulated from electrically conductive process material, and have all connections to chassis ground broken. It should be noted that a floated sheath may result in a less noise immune thermocouple signal.

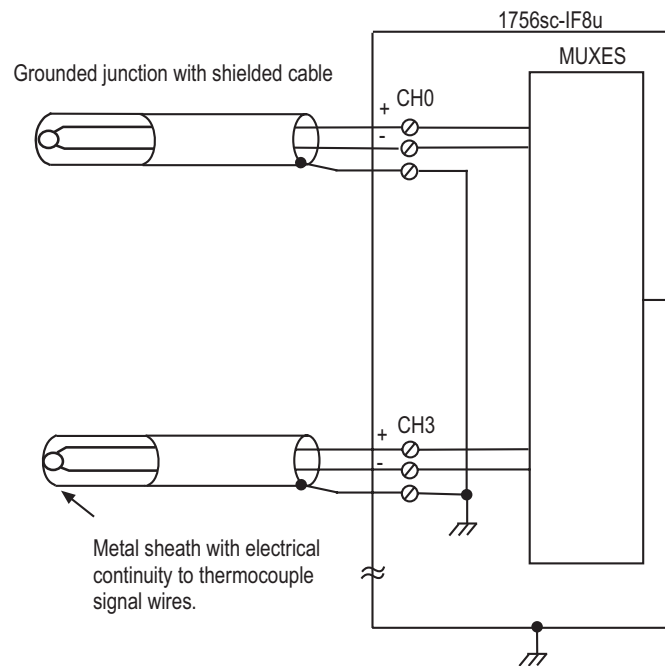

Exposed Junction Thermocouples

As shown in the illustration that follows, using exposed junction thermocouples may result in removal of channel to channel isolation. This may occur if multiple exposed thermocouples are in direct contact with electrically conductive process material. To prevent violation of channel to channel isolation:

- For multiple exposed thermocouples, do not allow the measuring junction of the thermocouple to make direct contact with electrically conductive process material.
- Use a single exposed junction thermocouple with multiple ungrounded junction thermocouples.
- Use all ungrounded junction thermocouple instead of the exposed junction type.

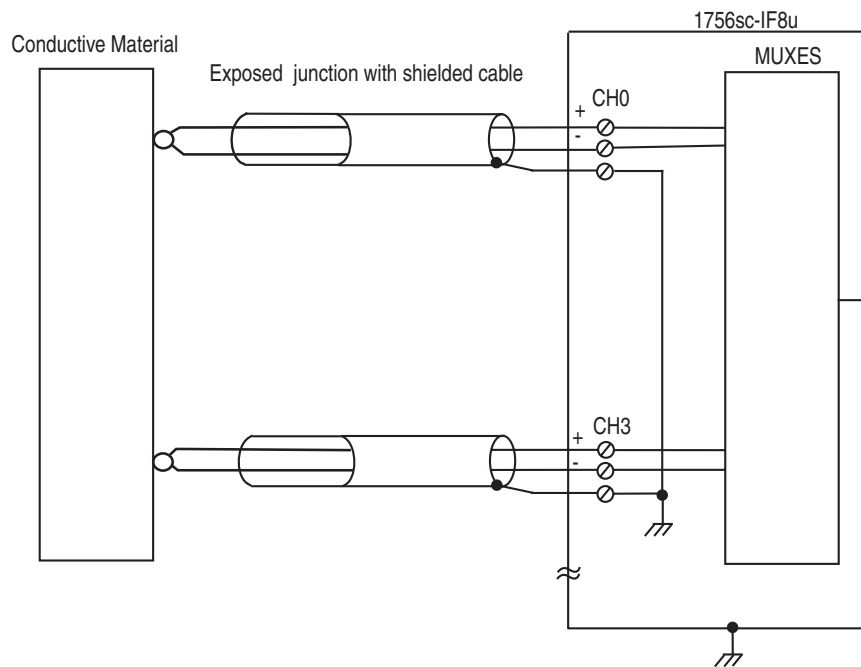

Programming Your Module

This chapter explains how program your module in the ControlLogix system. It also describes how to the module's input configuration are incorporated into your ladder logic program. Topics discussed include:

- importing the module's configuration profile
- reviewing accessing and altering configuration options.
- configuring the modules input type and filter settings
- configuring alarms and limits

Module Installation

Incorporating your module into the system is similar to adding any type of I/O module. You will use your RSLogix 5000 programming software. The module is not currently in the pick list of this software so you will use the Generic 1756 Module option as your starting point. This feature allows you to inport the configuration database into your project and use ladder logic to set the attributes of each tag. These settings control features such as the modules input type, channel input range, data format, filter frequency, etc.

You will need to download the sample project from our website and then import this into your program. Then you may access the controller tags to configure the module. Ladder logic samples are also provided with this sample project.

Adding Your Module to a Project

The module has a unique set of tag definitions which are used to configure specific features. Chapter 5, *Channel Configuration, Data, and Status*, gives you detailed information about the data content of the configuration. These values are set using your programming software and ladder logic. Before you can use these feature you must first include the module into the project.

1. Open your project and go to the “Add I/O module” menu under controller configuration.
2. You will now see the list of all I/O modules. Select the “Generic 1756 I/O” option.

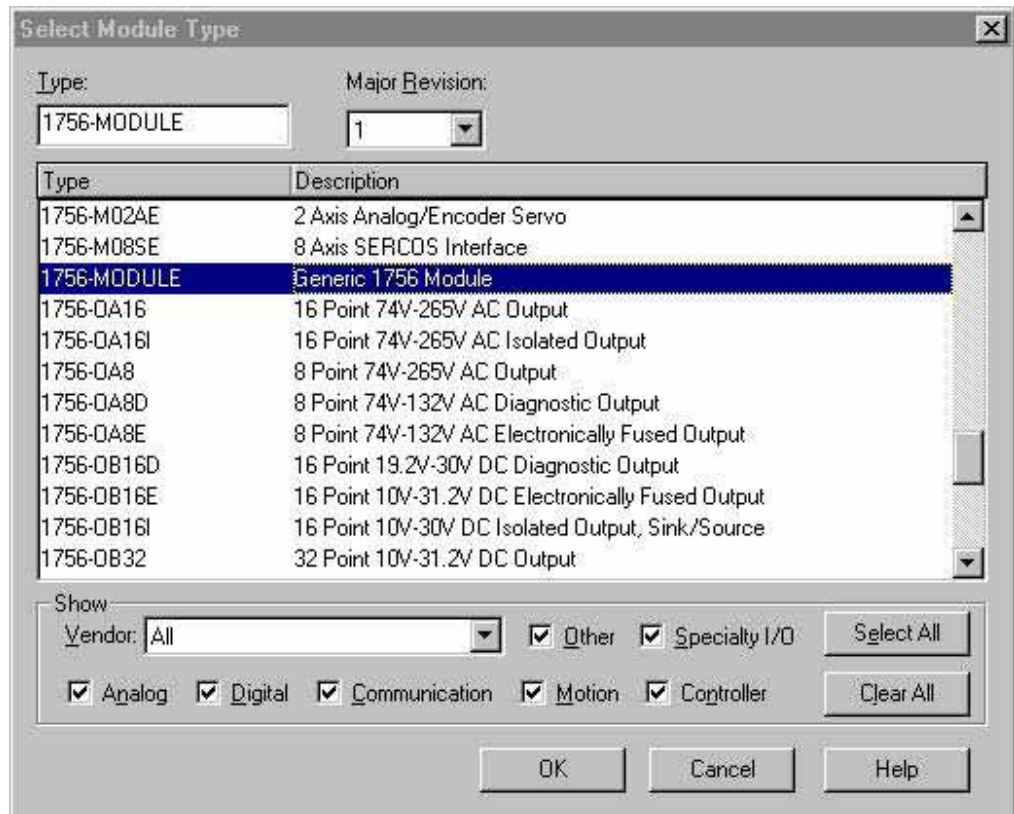

3. After clicking “OK” you are presented with the following dialog for setting up the general information about the module. Use the same values specified here:

Owner Controller Connection (Controller provides configuration)

Module Properties - Local:1 (1756-MODULE 1.1)

General | **Connection** | Module Info | Backplane

Type: 1756-MODULE Generic 1756 Module
Parent: Local

Name: IF8u
Description:
Comm Format: Input Data - DINT
Slot: 1

Connection Parameters

	Assembly Instance:	Size:	
Input:	226	23	(32-bit)
Output:	227		
Configuration:	225	396	(8-bit)
Status Input:			
Status Output:			

Status: Offline

OK Cancel Apply Help

Listen-only controller connection. (Controller does not provide configuration but monitors input data only. Another owner controller must exist.)

Module Properties - Local:2 (1756-MODULE 1.1)

General | **Connection** | Module Info | Backplane

Type: 1756-MODULE Generic 1756 Module
Parent: Local

Name: IF8U
Description:
Comm Format: Input Data - DINT
Slot: 2

Connection Parameters

	Assembly Instance:	Size:	
Input:	226	23	(32-bit)
Output:	229		
Configuration:	228	1	(8-bit)
Status Input:			
Status Output:			

Status: Offline

OK Cancel Apply Help

4. Specify an RPI interval between 10.0 and 750.0 ms:

Module Properties - Local:1 (1756-MODULE 1.1)

Requested Packet Interval (RPI): ms (0.2 - 750.0 ms)

Inhibit Module

Major Fault On Controller If Connection Fails While in Run Mode

Module Fault

Getting Technical Assistance

If you need technical assistance, please review the information in Chapter 6, “Testing Your Module,” before calling your local distributor of Spectrum Controls.

Note that your module contains electronic components which are susceptible to damage from electrostatic discharge (ESD). An electrostatic charge can accumulate on the surface of ordinary plastic wrapping or cushioning material. **In the unlikely event that the module should need to be returned to Spectrum Controls, please ensure that the unit is enclosed in approved ESD packaging (such as static-shielding / metallized bag or black conductive container).** Spectrum Controls reserves the right to void the warranty on any unit that is improperly packaged for shipment.

For further information or assistance, please contact your local distributor, or call the Spectrum Controls technical Support at :

USA - 440-646-6900

United Kingdom - 01908 635230

Australia - 800-809-929 or (61) 398-990-335

Brazil - (55) 11 3618 8800

Europe - (49) 2104 960 333

Declaration of Conformity

Declaration available upon request.



©2002-2011 Spectrum Controls, Inc. All rights reserved. Specifications subject to change without notice.
The Encompass logo and ControlLogix are trademarks of Rockwell Automation.
Publication 0300191-04 Rev. A May 2011. Printed in U.S.A.

Corporate Headquarters
Spectrum Controls Inc.
P.O. Box 6489
Bellevue, WA 98008 USA
Fax: 425-641-9473
Tel: 425-746-9481

Web Site: www.spectrumcontrols.com
E-mail: spectrum@spectrumcontrols.com

