



KRAMER ELECTRONICS LTD.

USER MANUAL

MODEL:

622T

Dual Link DVI Optical
Transmitter

622R

Dual Link DVI Optical
Receiver



622T/R Quick Start Guide

This guide helps you install and use your product for the first time. For more detailed information, go to http://www.kramerelectronics.com/support/product_downloads.asp to download the latest manual or scan the QR code on the left.

Step 1: Check what's in the box

- 622T/R Dual Link DVI Optical Transmitter/Receiver
- 1 Power supply per unit (5V DC)
- 1 DVI/DVI male-to-male cable
- 4 Rubber feet
- 1 Quick Start sheet

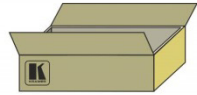

Save the original box and packaging materials in case you need to return your 622T/R for service.

Step 2: Install the 622T/R

Attach the rubber feet and place on a table or mount the 622T/R in a rack (using an optional RK-622 rack mount).

Step 3: Connect the inputs and outputs

Always switch off the power on each device before connecting it to your 622T/R.

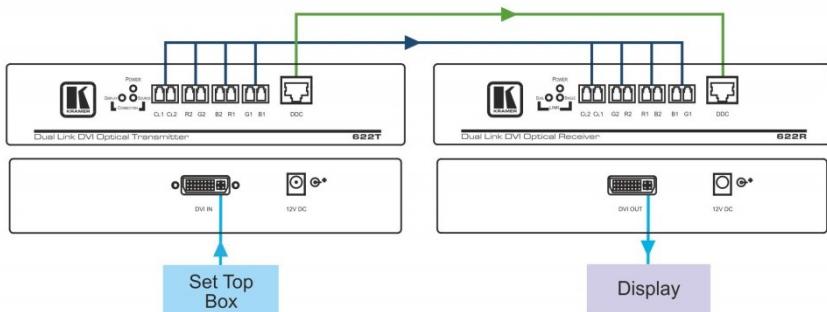

Always use Kramer high-performance cables for connecting AV equipment to the 622T/R.

Step 4: Connect the power

Connect the 5V DC power adapter to each unit of the 622T/R and plug the adapters into the mains electricity.



Contents

1	Introduction	1
2	Getting Started	2
2.1	Achieving the Best Performance	2
2.2	Safety Instructions	3
2.3	Recycling Kramer Products	3
3	Overview	4
3.1	About the Power Connect™ Feature	5
4	Defining the 622T, 622R Dual Link DVI Optical Transmitter/Receiver	6
4.1	Defining the 622T Dual Link DVI Optical Transmitter	6
4.2	Defining the 622R Dual Link DVI Optical Receiver	7
5	Connecting and Operating the 622T, 622R	8
5.1	Connecting the 622T/622R Dual Link DVI Optical Transmitter/Receiver	8
5.2	Operating the 622T/622R Dual Link DVI Optical Transmitter/Receiver	10
5.3	Wiring the TP LINE IN / LINE OUT RJ-45 Connectors	10
6	Technical Specifications	12

Figures

Figure 1:	622T Dual Link DVI Optical Transmitter	6
Figure 2:	622R Dual Link DVI Optical Receiver	7
Figure 3:	622T and 622R Dual Link DVI Optical Transmitter and Receiver System	8
Figure 4:	Connecting the 622T, 622R Dual Link DVI Optical Transmitter/Receiver	9
Figure 5:	TP PINOUT	10

1 Introduction

Welcome to Kramer Electronics! Since 1981, Kramer Electronics has been providing a world of unique, creative, and affordable solutions to the vast range of problems that confront video, audio, presentation, and broadcasting professionals on a daily basis. In recent years, we have redesigned and upgraded most of our line, making the best even better!

Our 1,000-plus different models now appear in 11 groups that are clearly defined by function: GROUP 1: Distribution Amplifiers; GROUP 2: Switchers and Routers; GROUP 3: Control Systems; GROUP 4: Format/Standards Converters; GROUP 5: Range Extenders and Repeaters; GROUP 6: Specialty AV Products; GROUP 7: Scan Converters and Scalers; GROUP 8: Cables and Connectors; GROUP 9: Room Connectivity; GROUP 10: Accessories and Rack Adapters and GROUP 11: Sierra Products.

Congratulations on purchasing your Kramer **622T, 622R Dual Link DVI Optical** Transmitter/Receiver, which is ideal for the following typical applications:

- Digital display systems
- Flat panel displays, plasma display panels and projectors in conference rooms and auditoriums
- Kiosks with digital flat panel displays for information display

2 Getting Started

We recommend that you:

- Unpack the equipment carefully and save the original box and packaging materials for possible future shipment
- Review the contents of this user manual



Go to <http://www.kramerelectronics.com> to check for up-to-date user manuals, application programs, and to check if firmware upgrades are available (where appropriate).

2.1 Achieving the Best Performance

To achieve the best performance:

- Use only good quality connection cables (we recommend Kramer high-performance, high-resolution cables) to avoid interference, deterioration in signal quality due to poor matching, and elevated noise levels (often associated with low quality cables)
- Do not secure the cables in tight bundles or roll the slack into tight coils
- Avoid interference from neighboring electrical appliances that may adversely influence signal quality
- Position your Kramer **622T**, **622R** away from moisture, excessive sunlight and dust



This equipment is to be used only inside a building. It may only be connected to other equipment that is installed inside a building.

2.2 Safety Instructions



Caution: There are no operator serviceable parts inside the unit

Warning: Use only the Kramer Electronics input power wall adapter that is provided with the unit

Warning: Disconnect the power and unplug the unit from the wall before installing

Warning: Do not look directly into the LC receptacles of the **622T**, while powered on, although this product is regulated strictly enough to operate under the Laser Class 1, classified by CDRH/FDA for eye safety

2.3 Recycling Kramer Products

The Waste Electrical and Electronic Equipment (WEEE) Directive 2002/96/EC aims to reduce the amount of WEEE sent for disposal to landfill or incineration by requiring it to be collected and recycled. To comply with the WEEE Directive, Kramer Electronics has made arrangements with the European Advanced Recycling Network (EARN) and will cover any costs of treatment, recycling and recovery of waste Kramer Electronics branded equipment on arrival at the EARN facility. For details of Kramer's recycling arrangements in your particular country go to our recycling pages at <http://www.kramerelectronics.com/support/recycling/>.

3 Overview

The high performance Kramer **622T** and **622R** have a transmission range of more than 300 ft. (more than 100 meters) of dual link high-resolution digital graphic data over fiber optic cables and EDID/HDCP parameters over DDC (UTP) cabling.

Using DDC (Digital Display Channel), the display can inform the video card about its properties, such as the maximum resolution and the color depth. The video card can then use this information to ensure that you are presented with valid options for configuring the display.

In particular, the **622T/622R** pair features:

- A dual-link DVI connection, supporting a resolution of up to 2560x1600 at 60Hz refresh rate
- A maximum data rate of 9.9Gbps (1.65Gbps per graphic channel)
- Transmission of two red, two green and two blue channels, and one clock – over the fiber optic cables, with 8 simplex or 4 duplex LC fiber connectors
- DDC/HDCP interconnection over CAT 5 with RJ-45 connectors, and also provides power via the UTP cable
- Strict regulation under the Class 1 Laser Eye Safety in compliance with FDA/CDRH and IEC 60825-1
- Compliance with the limits for a Class A digital device, pursuant to part 15 and 2 of FCC and CE
- Freedom from any special memory size, CPU speed and chipsets, when using a computer
- Backward compatibility with the DVI 1.0 standard

3.1 About the Power Connect™ Feature

The Power Connect™ feature here means that only one unit in a system, the transmitter or receiver, needs to be connected to a power source when the devices are within 90m (270ft) of each other. The Power Connect™ feature applies as long as the cable can carry power and the distance does not exceed 90m on standard TP cable. For longer distances, use heavy gauge cable (TP cable is still suitable for the video/audio transmission, but not for feeding the power at these distances).

4 Defining the 622T, 622R Dual Link DVI Optical Transmitter/Receiver

This section defines the dual link DVI Optical Transmitter/Receiver:

- **622T Dual Link DVI Optical Transmitter** (see [Section 4.1](#))
- **622R Dual Link DVI Optical Receiver** (see [Section 4.2](#))

4.1 Defining the 622T Dual Link DVI Optical Transmitter

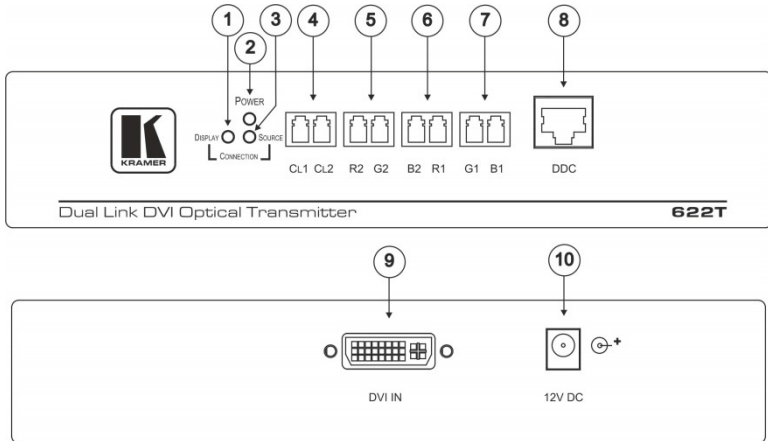

Figure 1: 622T Dual Link DVI Optical Transmitter

#	Feature		Function
1	CONNECTION	DISPLAY LED	Lights when a DVI display is connected to the 622R
2	POWER LED		Lights when receiving power
3	CONNECTION	SOURCE LED	Lights when a DVI source is detected
4	Optic Cables	CL1 CL2	Connects to the clock connectors on the 622R
5		R2 G2	
6		B2 R1	
7		G1 B1	
8	DDC CAT 5 Connector		Connects to the DDC RJ-45 connector on the 622R using a UTP CAT 5 cable with RJ-45 connectors at both ends
9	DVI IN Connector		Connects to the DVI source
10	12V DC		12V DC connector for powering the unit

4.2 Defining the 622R Dual Link DVI Optical Receiver

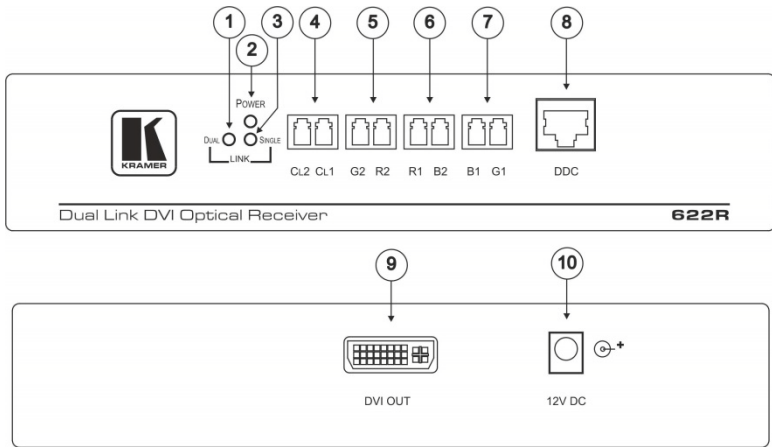

Figure 2: 622R Dual Link DVI Optical Receiver

#	Feature	Function	
1	LINK DUAL LED	Lights when the second link is present	
2	POWER LED	Illuminates when receiving power	
3	LINK SINGLE LED	Lights when the first link is present	
4	Optic Cables	CL1 CL2	Connects to the clock connectors on the 622T
5		R2 G2	
6		B2 R1	
7		G1 B1	
8	DDC CAT 5 Connector	Connects to the DDC RJ-45 connector on the 622T using a UTP CAT 5 cable with RJ-45 connectors at both ends	
9	DVI OUT Connector	Connects to the DVI acceptor	
10	12V DC	12V DC connector for powering up the unit	

5 Connecting and Operating the 622T, 622R



Always switch off the power to each device before connecting it to your **622T**, **622R**. After connecting your **622T**, **622R**, connect its power and then switch on the power to each device.

We recommend testing your system configuration by first connecting the entire system (as illustrated in [Figure 3](#)), using short copper cables instead of optical fiber cables.

You can use the **622T** and **622R** to configure a dual link DVI optical transmitter and receiver system as illustrated in [Figure 3](#): the source connects to the **622T**, the **622R** connects to the display, and both transmitter and receiver are interconnected via fiber optics and UTP cabling.

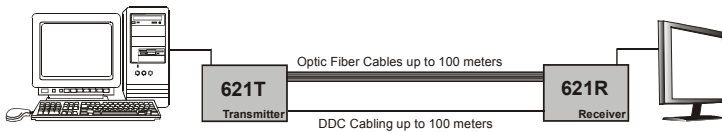

Figure 3: 622T and 622R Dual Link DVI Optical Transmitter and Receiver System

5.1 Connecting the 622T/622R Dual Link DVI Optical Transmitter/Receiver

To connect the **622T Dual Link DVI Optical Transmitter** with the **622R Dual Link DVI Optical Receiver**, as the example in [Figure 4](#) illustrates, do the following:

1. Connect the DVI source (for example, a set top box) to the 622T DVI IN connector, using the dual link DVI copper cable.
Make sure that the system is not powered up when connecting the DVI source.
2. On the 622R, connect the DVI OUT connector to the DVI acceptor (for example, a display), using the dual link DVI copper cable.
3. Remove the module dust covers and connect each duplex LC fiber cable one-by-one to each of the eight LC receptacles of the 622T and 622R.
4. Carefully recheck the polarities and ensure that the duplex connectors are fully engaged.



Do not look directly into the LC receptacles of the **622T**, while powered on, although this product is regulated strictly enough to operate under the Laser Class 1, classified by CDRH/FDA for eye safety.

5. Connect the DDC RJ-45C connector on the **622T** to the DDC RJ-45C connector on the **622R**, via UTP cabling (see [Section 5.3](#)).
6. Connect the 12V 2.1A DC power adapter to the power socket of either the 622T or the 622R and connect the adapter to the mains electricity (not shown).
Alternatively, connect the separate power supplies to the transmitter and to the receiver simultaneously.
7. Turn the power on the source and the display to ON.

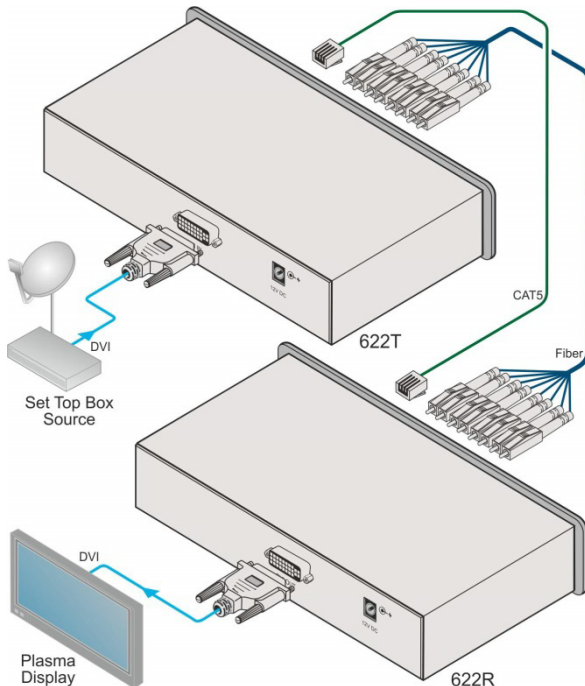

Figure 4: Connecting the 622T, 622R Dual Link DVI Optical Transmitter/Receiver

5.2 Operating the 622T/622R Dual Link DVI Optical Transmitter/Receiver

To properly operate the **622T/622R** system:

- Make sure you have a media receiver or a graphic controller card with a dual link DVI connector on your PC/Mac or SUN system.
- Make sure that your graphic card supports the maximum resolution of the display you are about to connect
- Avoid “hot plugging” the **622T** or **622R**. This is not a recommended practice with live digital voltages

5.3 Wiring the TP LINE IN / LINE OUT RJ-45 Connectors

This section defines the TP pinout, using a **straight** pin-to-pin cable with RJ-45 connectors.



Note, that the cable ground shielding must be connected / soldered to the connector shield.

EIA /TIA 568B	
PIN	Wire Color
1	Orange / White
2	Orange
3	Green / White
4	Blue
5	Blue / White
6	Green
7	Brown / White
8	Brown

Figure 5: TP PINOUT

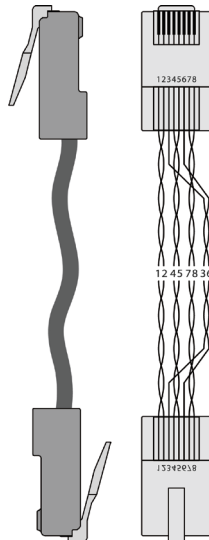

The RJ-45 pin assignments are as follows:

PIN	Symbol	Description
1	DDC Data GND	DDC Data line return ground
2	DDC Data	DDC Data line for (HDMI Digital Display Channel) DDC2B communication
3	DDC Clock GND	DDC Clock line return ground
4	Power GND	Main power return ground
5	Power	Main power for Kramer module
6	DDC Clock	DDC Clock line for (HDMI Digital Display Channel) DDC2B communication
7	5V_IN	DVI 5V (DVI No. 14 pin for Display)
8	HPD	Signal is driven by monitor to enable the system to identify the presence of a Display

6 Technical Specifications

	622T	622R
INPUTS:	DVI IN (DVI-D on a DVI-I connector)	8 simplex (or 4 duplex) LC optical connectors – 2 red, 2 green, 2 blue & 2 clock; 1 twisted pair on an RJ-45 connector for DDC and HDCP bidirectional data
OUTPUTS:	8 simplex (or 4 duplex) LC optical connectors – 2 red, 2 green, 2 blue & 2 clock; 1 twisted pair on an RJ-45 connector for DDC and HDCP bidirectional data	DVI OUT (DVI-D on a DVI-I connector)
MAX. DATA RATE	9.9Gbps (1.65Gbps per graphic channel)	
POWER CONSUMPTION:	12V DC 200mA	
OPERATING TEMPERATURE:	0° to +40°C (32° to 104°F)	
STORAGE TEMPERATURE:	-40° to +70°C (-40° to 158°F)	
HUMIDITY:	10% to 90%, RHL non-condensing	
DIMENSIONS:	21.4cm x 10.35cm x 4.36cm (8.4" x 4.07" x 1.71") W, D, H	
WEIGHT:	0.7 kg. (1.55 lbs.) approx.	
ACCESSORIES:	Power supply, bracket installation kit, 1 DVI/DVI male to male cable	
OPTIONS:	RK-622 19" rack adapter	
Specifications are subject to change without notice at http://www.kramerelectronics.com		

LIMITED WARRANTY

The warranty obligations of Kramer Electronics for this product are limited to the terms set forth below.

What is Covered

This limited warranty covers defects in materials and workmanship in this product.

What is Not Covered

This limited warranty does not cover any damage, deterioration or malfunction resulting from any alteration, modification, improper or unreasonable use or maintenance, misuse, abuse, accident, neglect, exposure to excess moisture, fire, improper packing and shipping (such claims must be presented to the carrier), lightning, power surges, or other acts of nature. This limited warranty does not cover any damage, deterioration or malfunction resulting from the installation or removal of this product from any installation, any unauthorized tampering with this product, any repairs attempted by anyone unauthorized by Kramer Electronics to make such repairs, or any other cause which does not relate directly to a defect in materials and/or workmanship of this product. This limited warranty does not cover cartons, equipment enclosures, cables or accessories used in conjunction with this product.

Without limiting any other exclusion herein, Kramer Electronics does not warrant that the product covered hereby, including, without limitation, the technology and/or integrated circuit(s) included in the product, will not become obsolete or that such items are or will remain compatible with any other product or technology with which the product may be used.

How Long Does this Coverage Last

Seven years as of this printing; please check our Web site for the most current and accurate warranty information.

Who is Covered

Only the original purchaser of this product is covered under this limited warranty. This limited warranty is not transferable to subsequent purchasers or owners of this product.

What Kramer Electronics will do

Kramer Electronics will, at its sole option, provide one of the following three remedies to whatever extent it shall deem necessary to satisfy a proper claim under this limited warranty:

1. Elect to repair or facilitate the repair of any defective parts within a reasonable period of time, free of any charge for the necessary parts and labor to complete the repair and restore this product to its proper operating condition. Kramer Electronics will also pay the shipping costs necessary to return this product once the repair is complete.
2. Replace this product with a direct replacement or with a similar product deemed by Kramer Electronics to perform substantially the same function as the original product.
3. Issue a refund of the original purchase price less depreciation to be determined based on the age of the product at the time remedy is sought under this limited warranty.

What Kramer Electronics will not do Under This Limited Warranty

If this product is returned to Kramer Electronics or the authorized dealer from which it was purchased or any other party authorized to repair Kramer Electronics products, this product must be insured during shipment, with the insurance and shipping charges prepaid by you. If this product is returned uninsured, you assume all risks of loss or damage during shipment. Kramer Electronics will not be responsible for any costs related to the removal or re-installation of this product from or into any installation. Kramer Electronics will not be responsible for any costs related to any setting up this product, any adjustment of user controls or any programming required for a specific installation of this product.

How to Obtain a Remedy under this Limited Warranty

To obtain a remedy under this limited warranty, you must contact either the authorized Kramer Electronics reseller from whom you purchased this product or the Kramer Electronics office nearest you. For a list of authorized Kramer Electronics resellers and/or Kramer Electronics authorized service providers, please visit our web site at www.kramerelectronics.com or contact the Kramer Electronics office nearest you.

In order to pursue any remedy under this limited warranty, you must possess an original, dated receipt as proof of purchase from an authorized Kramer Electronics reseller. If this product is returned under this limited warranty, a return authorization number, obtained from Kramer Electronics, will be required. You may also be directed to an authorized reseller or a person authorized by Kramer Electronics to repair the product.

If it is decided that this product should be returned directly to Kramer Electronics, this product should be properly packed, preferably in the original carton, for shipping. Cartons not bearing a return authorization number will be refused.

Limitation on Liability

THE MAXIMUM LIABILITY OF KRAMER ELECTRONICS UNDER THIS LIMITED WARRANTY SHALL NOT EXCEED THE ACTUAL PURCHASE PRICE PAID FOR THE PRODUCT. TO THE MAXIMUM EXTENT PERMITTED BY LAW, KRAMER ELECTRONICS IS NOT RESPONSIBLE FOR DIRECT, SPECIAL, INCIDENTAL OR CONSEQUENTIAL DAMAGES RESULTING FROM ANY BREACH OF WARRANTY OR CONDITION, OR UNDER ANY OTHER LEGAL THEORY. Some countries, districts or states do not allow the exclusion or limitation of relief, special, incidental, consequential or indirect damages, or the limitation of liability to specified amounts, so the above limitations or exclusions may not apply to you.

Exclusive Remedy

TO THE MAXIMUM EXTENT PERMITTED BY LAW, THIS LIMITED WARRANTY AND THE REMEDIES SET FORTH ABOVE ARE EXCLUSIVE AND IN LIEU OF ALL OTHER WARRANTIES, REMEDIES AND CONDITIONS, WHETHER ORAL OR WRITTEN, EXPRESS OR IMPLIED. TO THE MAXIMUM EXTENT PERMITTED BY LAW, KRAMER ELECTRONICS SPECIFICALLY DISCLAIMS ANY AND ALL IMPLIED WARRANTIES, INCLUDING, WITHOUT LIMITATION, WARRANTIES OF MERCHANTABILITY AND FITNESS FOR A PARTICULAR PURPOSE. IF KRAMER ELECTRONICS CANNOT LAWFULLY DISCLAIM OR EXCLUDE IMPLIED WARRANTIES UNDER APPLICABLE LAW, THEN ALL IMPLIED WARRANTIES COVERING THIS PRODUCT, INCLUDING WARRANTIES OF MERCHANTABILITY AND FITNESS FOR A PARTICULAR PURPOSE, SHALL APPLY TO THIS PRODUCT AS PROVIDED UNDER APPLICABLE LAW.

IF ANY PRODUCT TO WHICH THIS LIMITED WARRANTY APPLIES IS A "CONSUMER PRODUCT" UNDER THE MAGNUSON-MOSS WARRANTY ACT (15 U.S.C.A. §2301, ET SEQ.) OR OTHER APPLICABLE LAW, THE FOREGOING DISCLAIMER OF IMPLIED WARRANTIES SHALL NOT APPLY TO YOU, AND ALL IMPLIED WARRANTIES ON THIS PRODUCT, INCLUDING WARRANTIES OF MERCHANTABILITY AND FITNESS FOR THE PARTICULAR PURPOSE, SHALL APPLY AS PROVIDED UNDER APPLICABLE LAW.

Other Conditions

This limited warranty gives you specific legal rights, and you may have other rights which vary from country to country or state to state.

This limited warranty is void if (i) the label bearing the serial number of this product has been removed or defaced, (ii) the product is not distributed by Kramer Electronics or (iii) this product is not purchased from an authorized Kramer Electronics reseller. If you are unsure whether a reseller is an authorized Kramer Electronics reseller, please visit our Web site at www.kramerelectronics.com or contact a Kramer Electronics office from the list at the end of this document.

Your rights under this limited warranty are not diminished if you do not complete and return the product registration form or complete and submit the online product registration form. Kramer Electronics thanks you for purchasing a Kramer Electronics product. We hope it will give you years of satisfaction.



For the latest information on our products and a list of Kramer distributors, visit our Web site where updates to this user manual may be found.

We welcome your questions, comments, and feedback.

Web site: www.kramerelectronics.com

E-mail: info@kramerel.com



SAFETY WARNING

Disconnect the unit from the power supply before opening and servicing

Laser Compliance

LASER PRODUCT

Laser Class 1 acc. 21 CFR 1040 and Class 1 per IEC 60825-1

P/N: 2300-000104



Rev: 4

