

Installation and Start-Up Instructions

NOTE: Read the entire instruction manual before starting the installation.

SAFETY CONSIDERATIONS

Improper installation, adjustment, alteration, service, maintenance, or use can cause explosion, fire, electrical shock, or other conditions which may cause personal injury or property damage. Consult a qualified installer, service agency, or your distributor or branch for information or assistance. The qualified installer or agency must use factory-authorized kits or accessories when modifying this product. Refer to the individual instructions packaged with the kits or accessories when installing.

Follow all safety codes. Wear safety glasses and work gloves. Use quenching cloth for brazing operations. Have fire extinguisher available. Read these instructions thoroughly and follow all warnings or cautions attached to the unit. Consult local building codes and the National Electrical Code (NEC) for special installation requirements.

Recognize safety information. This is the safety-alert symbol . When you see this symbol on the unit or in instructions and manuals, be alert to the potential for personal injury.

Understand the signal word DANGER, WARNING, or CAUTION. These words are used with the safety-alert symbol. DANGER identifies the most serious hazards which **will** result in severe personal injury or death. WARNING signifies hazards which **could** result in personal injury or death. CAUTION is used to identify unsafe practices which **would** result in minor personal injury or product and property damage.

WARNING

Before installing or servicing system, always turn off main power to system. There may be more than 1 disconnect switch. Turn off accessory heater power if applicable. Electrical shock can cause personal injury or death.

INSTALLATION

Step 1—Check Equipment and Job Site

UNPACK UNIT — Move to final location. Remove carton taking care not to damage unit.

INSPECT EQUIPMENT — File claim with shipping company prior to installation if shipment is damaged or incomplete. Locate unit rating plate on unit corner panel. (See Fig. 2.) It contains information needed to properly install unit. Check rating plate to be sure unit matches job specifications.

Step 2—Install on a Solid, Level Mounting Pad

If conditions or local codes require the unit be attached to pad, tiedown bolts should be used and fastened through knockouts provided in unit base pan. Refer to unit mounting pattern in Fig. 2 to determine base pan size and knockout hole location.

When installing, allow sufficient space for airflow clearance, wiring, refrigerant piping, and service. Allow 30-in. clearance to service end of unit and 48 in. above unit. For proper airflow, a 6-in.

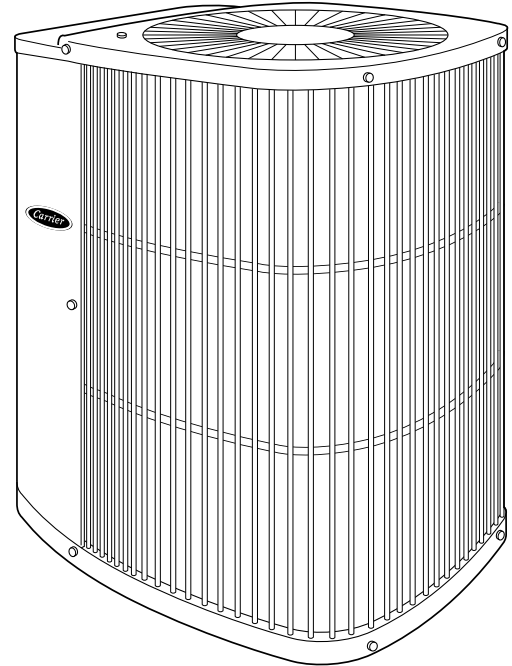

Fig. 1—Model 38YKC

A88160

clearance on 1 side of unit and 12 in. on all remaining sides must be maintained. Maintain a distance of 24 in. between units. Position so water, snow, or ice from roof or eaves cannot fall directly on unit.

On rooftop applications, locate unit at least 6 in. above roof surface. Place unit above a load-bearing wall and isolate unit and tubing set from structure.

Arrange supporting members to adequately support unit and minimize transmission of vibration to building. Consult local codes governing rooftop applications.

Step 3—Elevate Unit

For proper drainage the heat pump must be raised off the mounting surface. Fig. 4 shows unit with accessory heat pump feet installed. Use accessory heat pump snow rack in areas where prolonged subfreezing temperatures or heavy snow occur. Refer to separate Installation Instructions packaged with the accessories.

Step 4—Replace Indoor AccuRater® Piston (if required)

Check indoor coil piston to see if it matches the required piston shown on unit rating plate. (See Fig. 2.) If it does not match, replace indoor coil piston with piston shipped with this unit. The piston shipped with outdoor unit is correct for any approved indoor coil combination.

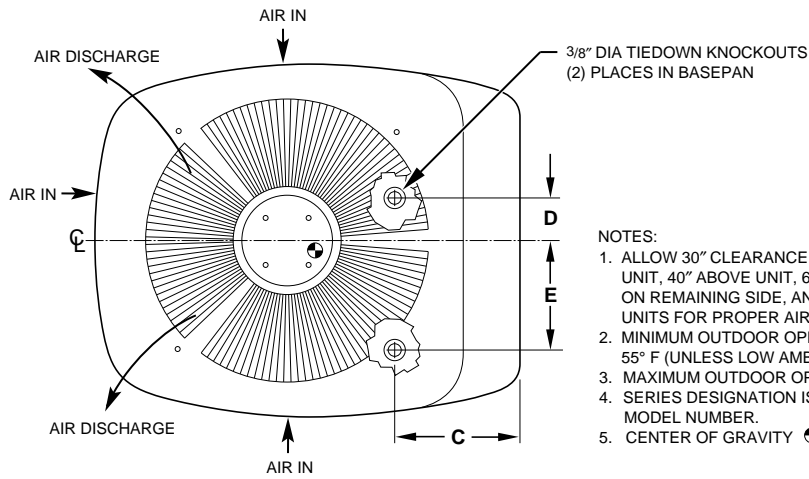

- NOTES:
1. ALLOW 30" CLEARANCE TO SERVICE END OF UNIT, 40" ABOVE UNIT, 6" ON ONE SIDE, 12" ON REMAINING SIDE, AND 24" BETWEEN UNITS FOR PROPER AIRFLOW.
 2. MINIMUM OUTDOOR OPERATING AMBIENT IN COOLING MODE IS 55° F (UNLESS LOW AMBIENT CONTROL IS USED) MAX 125° F.
 3. MAXIMUM OUTDOOR OPERATING AMBIENT IN HEATING MODE IS 66° F.
 4. SERIES DESIGNATION IS THE 13TH POSITION OF THE UNIT MODEL NUMBER.
 5. CENTER OF GRAVITY

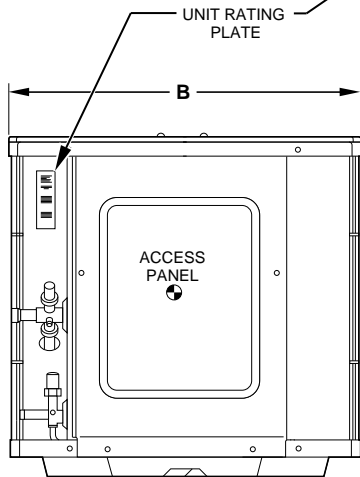
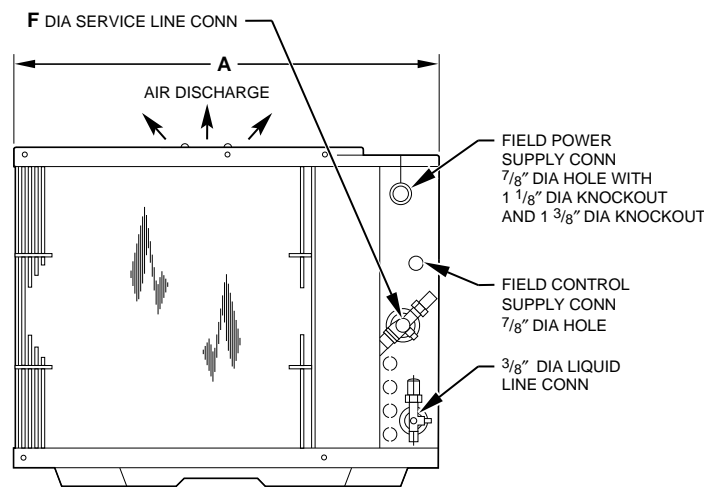

SERIAL		
MODEL		
PISTON	ID	OD
FACTORY CHARGED R-22		
PH	Hz	Volts
POWER SUPPLY		
PH	Hz	Volts
PERMISSIBLE VOLTAGE AT UNIT		
MAX	MIN	
SUITABLE FOR OUTDOOR USE		
COMPRESSOR		
Volts AC		
PH		
Hz		
FLA		
DESIGN/TEST PRESSURE GAGE		
Hi PSI	NPA	
Lo PSI	NPA	
MINIMUM CIRCUIT AMPS		
MAX OVERCURRENT PROTECTIVE DEVICE		
TYPE	USA	CANADA
MAX FUSE		
MAX WGR CMT-BKR	N/A	
MAX CMT-BKR	N/A	
UL		
CARRIER CORP INDIANAPOLIS IN 46206		

A92485

UNIT SIZE	A	B	C	D	E	F
	In.	In.	In.	In.	In.	In.
018, 024	27-1/2	22-1/2	8-3/16	2-13/16	6-15/16	5/8
030, 036	34-15/16	30	8-3/16	4	9-3/4	3/4
042-060	34-15/16	30	8-3/16	4	9-3/4	7/8

Fig. 2—Unit Reference Drawing

Table 1—Refrigerant Connections and Recommended Liquid and Vapor Tube Diameters (In.)

UNIT SIZE	LIQUID		VAPOR	
	Connect Diameter	Tube Diameter	Connect Diameter	Tube Diameter
018, 024	3/8	3/8	5/8	5/8
030, 036	3/8	3/8	3/4	3/4
042, 048	3/8	3/8	7/8	7/8
060	3/8	3/8	7/8	1-1/8

Note: Tube diameters are for lengths up to 50 ft. For tubing lengths greater than 50 ft, consult Long-Line Application Guideline.

CAUTION

DO NOT BURY MORE THAN 36 IN. OF REFRIGERANT TUBING IN GROUND. If any section of tubing is buried, there must be a 6-in. vertical rise to the valve connections on the outdoor unit. If more than the recommended length is buried, refrigerant may migrate to cooler buried section during extended periods of unit shutdown, causing refrigerant slugging and possible compressor damage at start-up.

Step 5—Make Piping Connections

Outdoor units may be connected to indoor sections using accessory tubing package or field-supplied refrigerant grade tubing of correct size and condition. For tubing requirements beyond 50 ft, consult Long-Line Application Guideline which is available from your local distributor.

CAUTION

In some cases noise in the living area has been traced to gas pulsations from improper installation of equipment.

INSTALLATION RECOMMENDATIONS

1. Locate the unit away from windows.

2. Ensure that vapor and liquid tube diameters are appropriate to the capacity of the unit. (See Table 1.)
3. Run refrigerant tubes as directly as possible by avoiding unnecessary turns and bends.
4. Leave some slack between the structure and the unit to absorb vibration.
5. When passing refrigerant tubes through the wall, seal the opening with RTV or other pliable silicon-based caulk. (See Fig. 3.)
6. Avoid direct tubing contact with water pipes, ductwork, floor joists, wall studs, floors, and walls.
7. Do not suspend refrigerant tubing from joists and studs with a rigid wire or strap which comes in direct contact with the tubing. (See Fig. 3.)
8. Ensure that tubing insulation is pliable and completely surrounds the vapor tube.
9. When necessary, use hanger straps which are 1 in. wide and conform to the shape of the tubing insulation. (See Fig. 3.)
10. Isolate the hanger straps from the insulation by using metal sleeves bent to conform to the shape of the insulation.

If refrigerant tubes or indoor coil is exposed to atmospheric conditions for longer than 5 minutes, it must be evacuated to 500 microns to eliminate contamination and moisture in the system.

NOTE: Avoid contact between tubing and structure

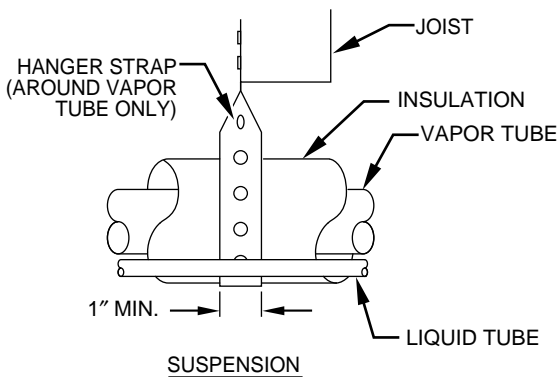
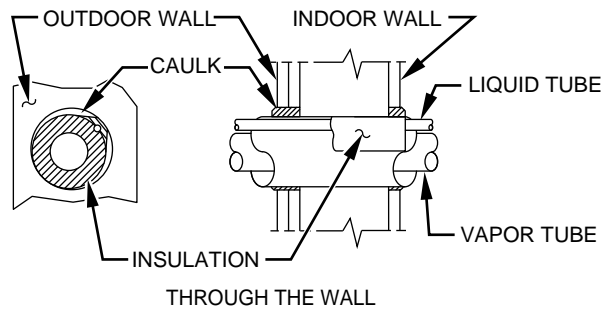

Fig. 3—Piping Installation

A94028

OUTDOOR UNIT CONNECTED TO FACTORY-APPROVED INDOOR UNIT — Outdoor unit contains correct system refrigerant charge for operation with indoor unit noted in ARI directory as tested combination when connected by 15 ft of field-supplied or factory accessory tubing. Check refrigerant charge for maximum efficiency. (See Section 9—Checking Charge.)

REFRIGERANT TUBING — Connect tubing to fittings on outdoor unit vapor and liquid service valves. (See Fig. 2 and 5.)

SWEAT CONNECTION — Remove plastic retainer holding outdoor piston in the liquid service valve and connect sweat/flare

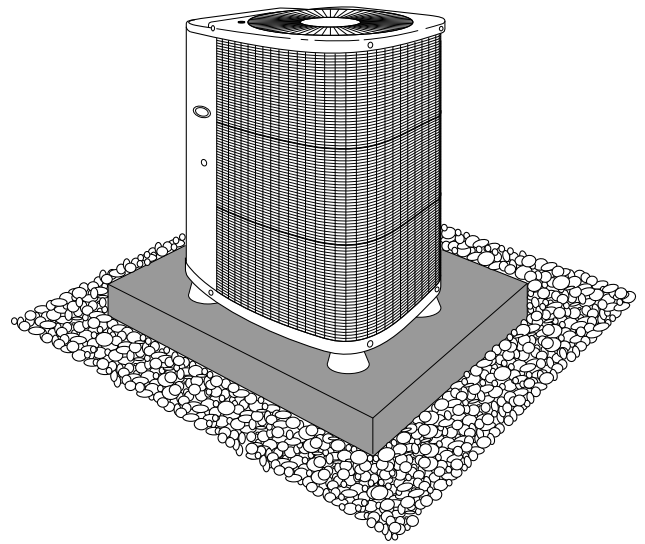

Fig. 4—Accessory Heat Pump Feet

A88277

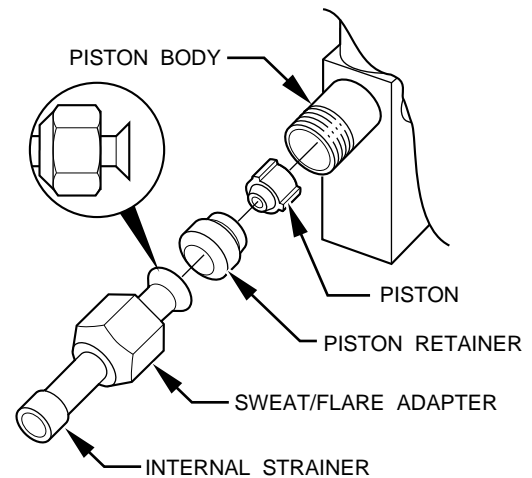

Fig. 5—Service Valve with Sweat Adapter Tube

A94029

adapter provided to valve. (See Fig. 5.) Connect refrigerant tubing to fittings on outdoor unit vapor and liquid service valves. Service valves are closed from factory and ready for brazing. After wrapping the service valve with a wet cloth, the tubing set can be brazed to the service valve using either silver bearing or non-silver bearing brazing material. Consult local code requirements. Refrigerant tubing and indoor coil are now ready for leak testing. This check should include all field and factory joints.

⚠ WARNING

Relieve pressure and recover all refrigerant before system repair or final unit disposal to avoid personal injury or death. Use all service ports and open all flow-control devices, including solenoid valves.

⚠ CAUTION

Do not vent refrigerant to atmosphere. Recover during system repair or final unit disposal.

⚠ CAUTION

A brazing shield **MUST** be used when tubing sets are being brazed to the service valves to prevent damage to the painted unit surface.

⚠ CAUTION

To avoid valve damage while brazing, service valves must be wrapped with a heat-sinking material such as a wet cloth.

Step 6—Make Electrical Connections

Be sure field wiring complies with local and national fire, safety and electrical codes, and voltage to system is within limits shown on unit rating plate. Contact local power company for correction of improper voltage. See unit rating plate for recommended circuit protection device.

NOTE: Operation of unit on improper line voltage constitutes abuse and could affect unit reliability. See unit rating plate. Do not install unit in system where voltage may fluctuate above or below permissible limits.

NOTE: Use copper wire only between disconnect switch and unit.

NOTE: Install branch circuit disconnect per NEC of adequate size to handle unit starting current. Locate disconnect within sight from and readily accessible from unit per Section 440-14 of NEC.

⚠ WARNING

To avoid personal injury or death, do not supply power to unit with compressor terminal box cover removed.

ROUTE GROUND AND POWER WIRES — Remove access panel and control box cover to gain access to unit wiring. Extend wires from disconnect through power wiring hole provided and into unit control box. (See Fig. 2.)

CONNECT GROUND AND POWER WIRES — Connect ground wire to ground connection in control box for safety. Connect power wiring to contactor as shown in Fig. 6.

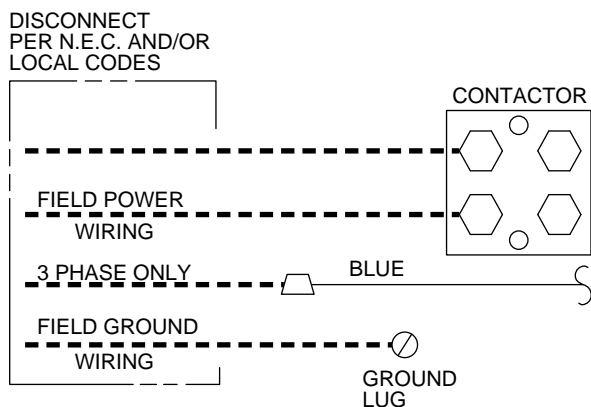

Fig. 6—Line Power Connections

A94025

⚠ WARNING

According to NEC, ANSI/NFPA 70, and local codes, the cabinet must have an uninterrupted or unbroken ground to minimize personal injury if an electrical fault should occur. The ground may consist of electrical wire or metal conduit when installed in accordance with existing electrical codes. Failure to follow this warning could result in an electric shock, fire, or death.

CONNECT CONTROL WIRING — Route 24-v control wires through control wiring grommet and connect leads to control wiring terminal board. (See Fig. 7.)

Use No. 18 AWG color-coded, insulated (35°C minimum) wires. If thermostat is located more than 100 ft from unit (as measured along the control voltage wires), use No. 16 AWG color-coded wires to avoid excessive voltage drop.

Use furnace transformer, fan coil transformer, or accessory transformer for control power, 24-v/40-va minimum.

NOTE: Use of available 24-v accessories may exceed the minimum 40-va power requirement. Determine total transformer loading and increase the transformer capacity or split the load with an accessory transformer as required.

NOTE: The defrost timer is factory set for 90-minute cycles. The timer can be field set for 30- and 50-minute cycles depending on defrost conditions in your geographic location.

Step 7—Install Electrical Accessories

Refer to the individual instructions packaged with the kits or accessories when installing.

⚠ CAUTION

Damage may occur to the scroll compressor if operated at a negative suction pressure during a system pumpdown.

Step 8—Start-up

1. If equipped with a crankcase heater, energize a minimum of 24 hrs before starting unit. To energize heater only, set thermostat at OFF position and close electrical disconnect to outdoor unit.
2. Fully open liquid and vapor service valves.
3. Unit is shipped with valve stem(s) front seated and caps installed. Replace stem caps after system is opened to refrigerant flow. Replace caps finger tight and tighten additional 1/6 turn using a backup wrench on valve body flats to prevent distortion of sheet metal.
4. Close electrical disconnects to energize system.
5. Set room thermostat at desired temperature.
6. Set room thermostat at HEAT or COOL and fan switch at ON or AUTO, as desired. Operate unit for 15 minutes. Check system refrigerant charge. (See Section 9.)

SEQUENCE OF OPERATION — With power supplied to indoor and outdoor units, transformer is energized.

Cooling

On a call for cooling, the thermostat makes circuits R-O, R-Y, and R-G. Circuit R-O energizes the reversing valve, switching it to cooling position. Circuit R-Y energizes the contactor, starting outdoor fan motor and compressor circuit. R-G energizes the indoor unit blower relay, starting the indoor blower motor on high speed.

When the thermostat is satisfied, its contacts open, de-energizing the contactor and blower relay. Compressor and motors should stop.

Heating

On a call for heating, the thermostat makes circuits R-Y and R-G. Circuit R-Y energizes contactor, starting outdoor fan motor and compressor. Circuit R-G energizes the indoor blower relay, starting the blower motor on high speed.

Should the temperature continue to fall, R-W2 is made through the second-stage room thermostat bulb. Circuit R-W2 energizes a sequencer, bringing on the first bank supplemental electric heat and providing electrical potential to the second heater sequencer (if used). If the outdoor temperature falls below the setting of the outdoor thermostat (field-installed option), the contacts close to complete the circuit and bring on the second bank of supplemental electric heat.

When the thermostat is satisfied, its contacts open, de-energizing the contactor and sequencer. All heaters and motors should stop.

Defrost

The defrost control is a time/temperature control which includes a field-selectable (quick connects located at board edge) time period between defrost cycles (30, 50, and 90 minutes), factory set at 90 minutes.

The electronic timer and the defrost cycle will start only when the contactor is energized and the defrost thermostat is closed.

The defrost mode is identical to the cooling mode except that the outdoor fan motor stops and a second-stage heat is turned on to continue warming the conditioned space.

Step 9—Checking Charge

Factory charge is shown on unit rating plate. (See Fig. 2.)

Adjust charge in cooling mode by following procedure shown on the subcooling charge tables located on unit information plate. Check charge in heating by following procedure shown on heating check chart located on unit information plate.

⚠ WARNING

Service valve gage ports are equipped with Schrader valves. To prevent personal injury, wear safety glasses and gloves when handling refrigerant.

⚠ CAUTION

Compressor damage may occur if system is overcharged.

⚠ CAUTION

Do not vent refrigerant to atmosphere. Recover during system repair or final unit disposal.

CARE AND MAINTENANCE

For continuing high performance and to minimize possible equipment failure, it is essential that periodic maintenance be performed on this equipment. Consult your servicing contractor or User's Manual for the proper frequency of maintenance. Frequency of maintenance may vary depending upon geographic areas, such as coastal applications.

Step 1—Leave User's Manual With Homeowner

Explain system operation and maintenance procedures outlined in User's Manual.

SYSTEMS WITH ONE OUTDOOR THERMOSTAT

SYSTEMS WITH TWO OUTDOOR THERMOSTATS

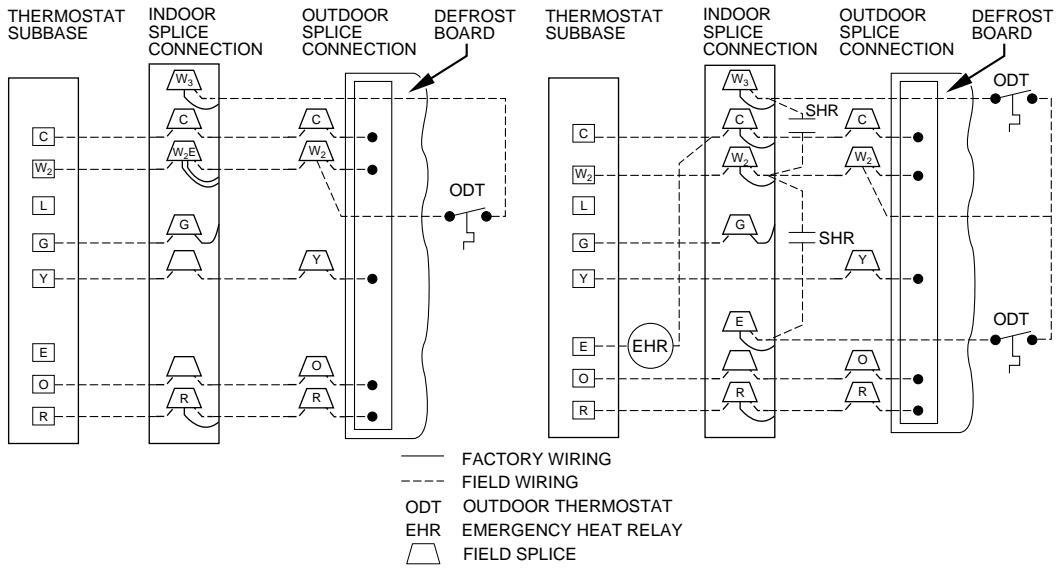

USED WITH FB4, FB5, FC4, FA4, FH4 FAN COILS

USED WITH FB4, FB5, FC4, FA4, FH4 FAN COILS

REMOVE WIRES FROM CRIMP NUT IN INDOOR FAN COIL WHEN INSTALLING OUTDOOR THERMOSTATS.

IMPORTANT: WHEN USING OUTDOOR THERMOSTATS, W₂ MUST BE ENERGIZED WHEN REQUESTING SUPPLEMENTAL HEAT.

A91327

SYSTEMS WITHOUT OUTDOOR THERMOSTATS

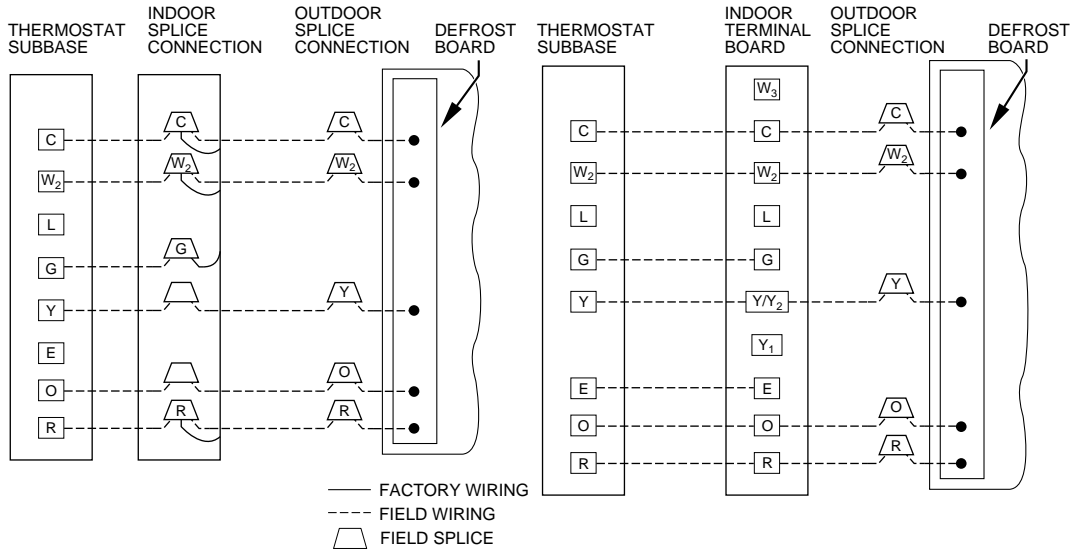

USED WITH FD3, FF1, FA4, FB4, FC4, FH4 FAN COILS

USED WITH FK4B FAN COIL

A91326

Fig. 7—Typical Circuit Connections