

Pro-face

PSS-CD01

Installation Guide

Preface

The PSS-CD01 (CD-ROM Drive Unit) is designed for use with Pro-face's Compact Panel Computer PS-3701A(Eden™ ESP6000 - 667MHz Model), hereafter referred to as the "PS-A" and for use with PL-X920 Series units, hereafter referred to as the "PL". While the PSS-CD01 provides a convenient way to install software into PS-A/PL unit hard disks, it is not designed to be used outside of the development environment.

Corresponding Products: PS-3701A (Eden™ ESP6000 - 667MHz Model) unit /
PL-X920 Series unit

Pro-face is a trademark of Digital Electronics Corporation, registered in Japan and other countries. All other trademarks/registered trademarks are the properties of their respective owners.



Warning - Safety Precautions

- Be sure to check that the PS-A/PL unit's power cord is disconnected before installing this unit. Failure to do so may cause an electric shock.
- Do not attempt to modify or open the PSS-CD01. This may cause a fire or an electric shock.
- Be sure to read the "2. PS-A Installation" or "3. PL Installation" section completely to ensure that the PSS-CD01 is correctly installed.

To Prevent Accidents

- Since the PSS-CD01 is a precision instrument, be sure it is neither hit by nor pressed strongly against another object.
- Be sure water, liquids or metal particles are not allowed to enter the PSS-CD01 unit's connector. Any of these may cause either a breakdown or an electric shock.
- Do not store or operate this unit in a location where there is direct sunlight, excessive heat, dust or vibration.
- Do not store or operate the PSS-CD01 near chemicals, or where there are chemical fumes.
- Do not use the PSS-CD01 in locations where corrosive gases are present.
- To prevent damage to file data, be sure to shut down the PS-A/PL unit's OS before turning OFF the main power.

Package Contents

Please check that the following items are included in your PSS-CD01 package.

■ **PSS-CD01 Unit** (1)

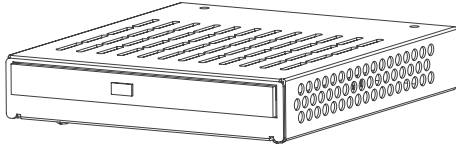

■ **Connection Cable** (1)

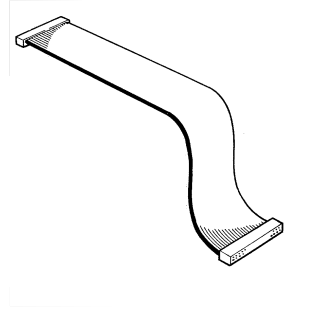

■ **PS-A Fastener (A)** (1)

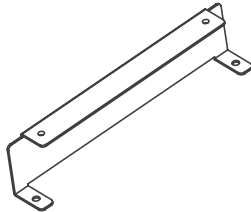

■ **PS-A Fastener (B)** (1)

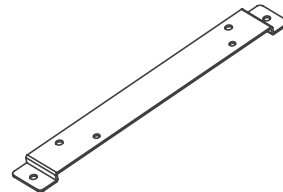

■ **PL Fastener (C)** (1)

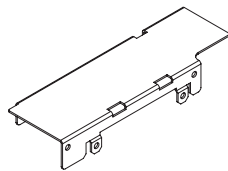

■ **PL Fastener (D)** (1)

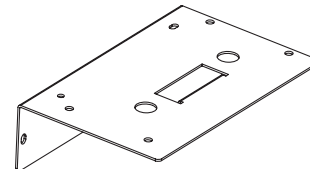

■ **Attachment Screws** (8)

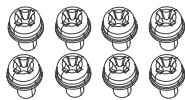

■ **Installation Guide** (1)

<This Guide>



Pro-face has taken utmost care to insure the quality of this product when it was shipped. However, for any reason, should you find any defects or damage, please contact your Pro-face representative immediately for service.

1 Hardware Specifications

■ Functional

Random Access Seek	115ms (Ave.)
Data Transfer Speed	16.7MB/s (Max.)
Disk Speed	5,136 rpm (typ)
Interface	IDE (ATAPI) ^{*1}
Power Consumption	During Startup: 1.0A (typ)
	During Random Access: 0.85A (typ)
	During Wait: 0.45A (typ)

**1 The PSS-CD01's connection cable is a special-purpose cable. Other types of cables cannot be used to connect this unit to the PS-A /PL unit.*

■ Environmental

Ambient Temperature	+5 °C to +50°C
Storage Temperature	-10°C to +60°C
Ambient Humidity	10%RH to 80%RH (no condensation)
Vibration Resistance	(during operation) 2.9m/s ² (10Hz to 25Hz)
Shock Resistance	(not operating) 588m/s ²

2 PS-A Installation

Be sure to use the following installation procedures to ensure that the PSS-CD01 is correctly installed. Installation procedures will differ depending on the type of PS-A unit you are using.



WARNING

Shock Danger! Be sure to unplug the PS-A unit from its power supply prior to installing the PSS-CD01.



Note: When using the PSS-CD01 with the PS-A unit, be sure to change the "IDE Primary Master PIO" and "IDE Primary Slave PIO" settings within the System Information area "INTEGRATED PERIPHERALS" to "Mode 2". Also, be sure to set the "IDE Primary Master UDMA" and "IDE Primary Slave UDMA" settings to "Disabled".

Reference *Compact Panel Computer PS-3701A (Eden™ ESP6000 - 667MHz Model) User Manual, Chapter 3 System Setup.*

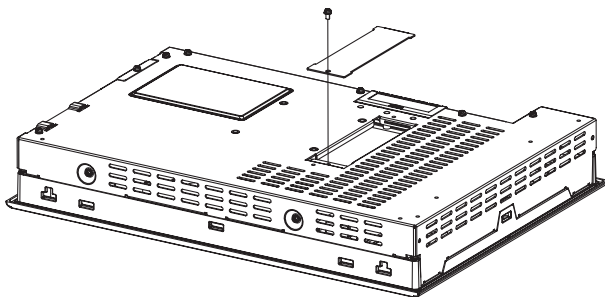

- 1) Unscrew the CD-ROM Drive I/F cover's attachment screw and remove the CD-ROM Drive I/F cover.

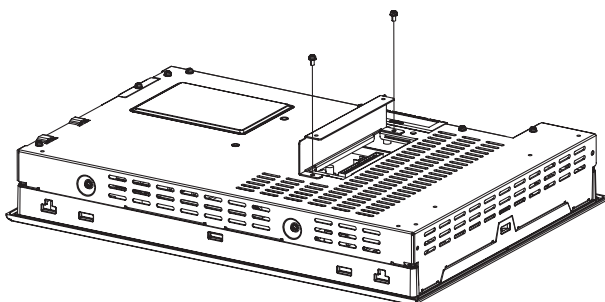

- 2) Secure PS-A fastener (A) to the rear of the PS-A unit using the two (2) attachment screws. Fastening torque should be 0.5 to 0.6N•m.

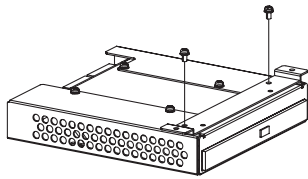

- 3) Secure PS-A fastener (B) to the PSS-CD01 using the two (2) attachment screws. Fastening torque should be 0.5 to 0.6N•m.

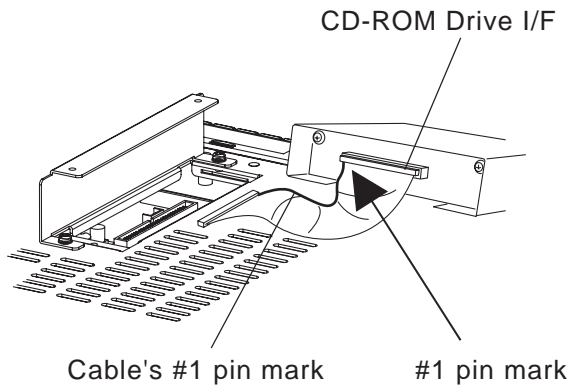

- 4) Connect the PSS-CD01 to the PS-A unit via the connection cable. Be sure to that the Cable's #1 pin mark and the connector are correctly aligned.

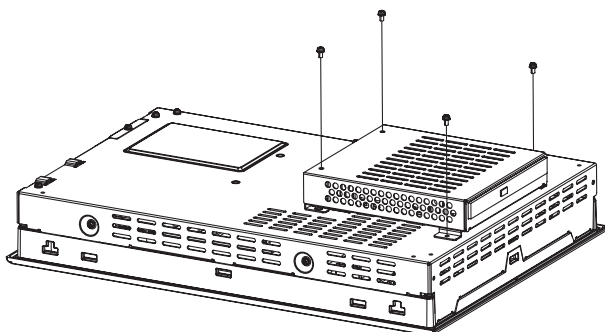

- 5) Secure the PSS-CD01 to the PS-A unit using the four (4) attachment screws. Fastening torque should be 0.5 to 0.6N•m. Place the cable in the space between the PSS-CD01 and the PS-A unit.



To be sure to prevent the cable from being caught between the PS-A unit and PSS-CD01 and possibly damaged.



CAUTION

Confirm that the connection cable is securely attached to both connectors. Be sure to check both connectors before turning the PS-A ON.

3

PL Installation

Be sure to use the following installation procedures to ensure that the PSS-CD01 unit is correctly installed. Installation procedures will differ depending on the type of PL unit you are using.



When the PSS-CD01 unit is used, the Slave HDD cannot be used. Be sure to uninstall (remove) the Slave HDD unit.



WARNING

Shock Danger! Be sure to unplug the PL unit from its power supply prior to installing the PSS-CD01 unit.



When using the CD-ROM drive unit with the PL-X920 Series unit, be sure to change the "IDE Primary Master PIO" and "IDE Primary Slave PIO" settings within the "System Information area | INTEGRATED PERIPHERALS" to "Mode 2". Also, be sure to set the "IDE Primary Master UDMA" and "IDE Primary Slave UDMA" settings to "Disabled".

Reference *PL Series User Manual, Chapter 5 System Setup.*

■ Connecting to a PL-X920 Series Unit

A) Connecting to a PL-X920 (2-Slot) Series Unit

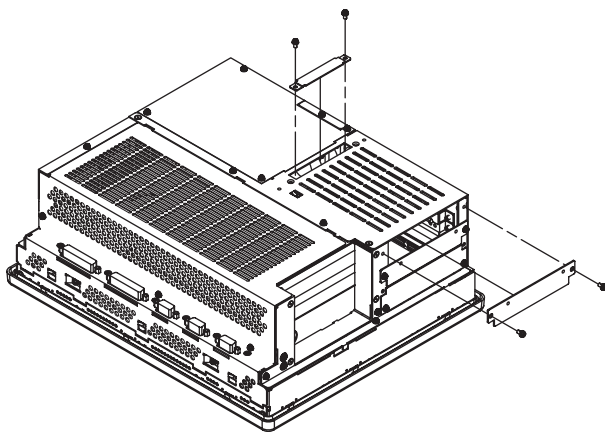

- 1) Unscrew the IDE I/F cover's two (2) attachment screws and the HDD1 slot's two (2) attachment screws. Remove the IDE I/F cover and the HDD1 slot cover.

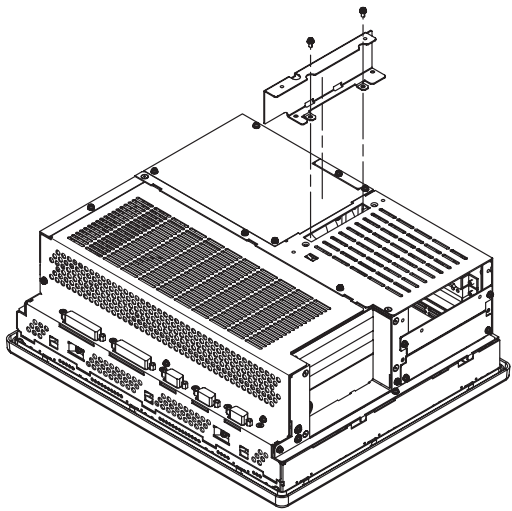

- 2) Secure PL fastener (C) to the rear of the PL unit using the two (2) attachment screws.

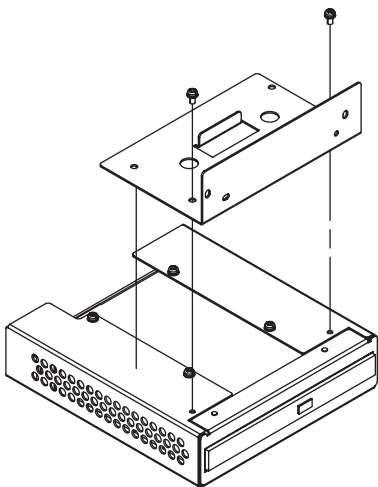

- 3) Secure PL fastener (D) to the PSS-CD01 unit using the two (2) attachment screws.

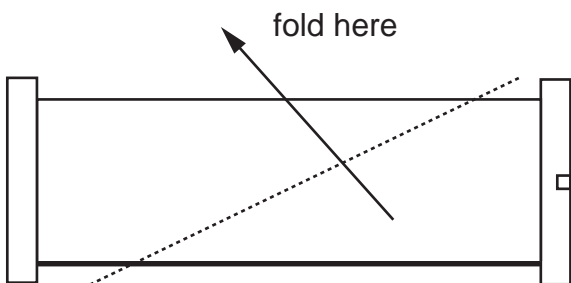

- 4) As shown in the left-side figure, fold the cable over, along the dotted line.

IDE INTERFACE

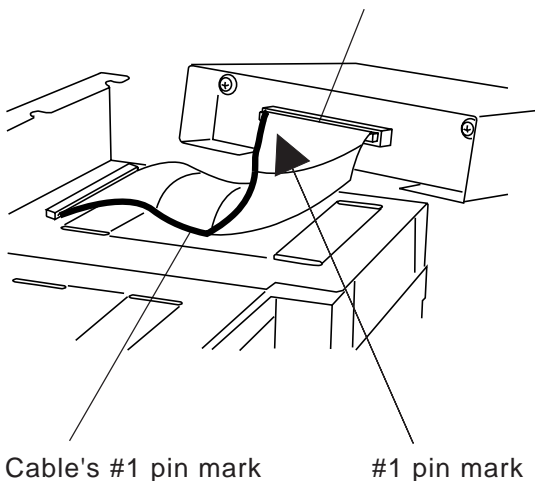

- 5) Connect the PSS-CD01 unit to the PL unit via the connection cable. Be sure to confirm that the Cable's #1 pin mark and the connector are correctly aligned.

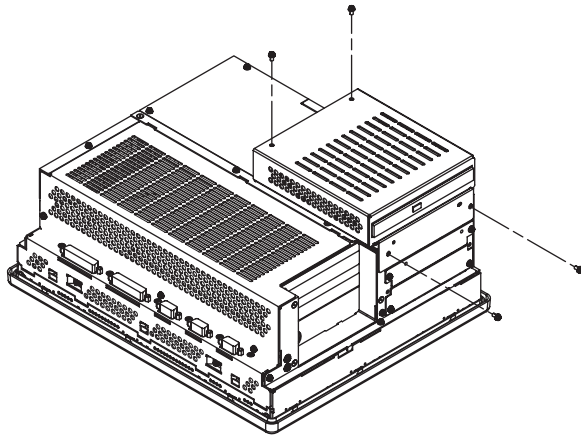

- 6) Secure the PSS-CD01 unit to the PL unit using the four (4) attachment screws. Place the cable in the space between the PSS-CD01 and the PL unit.



To be sure to prevent the cable from being caught between the PL unit and PSS-CD01 and possibly damaged.

B) Connecting to a PL-X920 (4-Slot) Series Unit

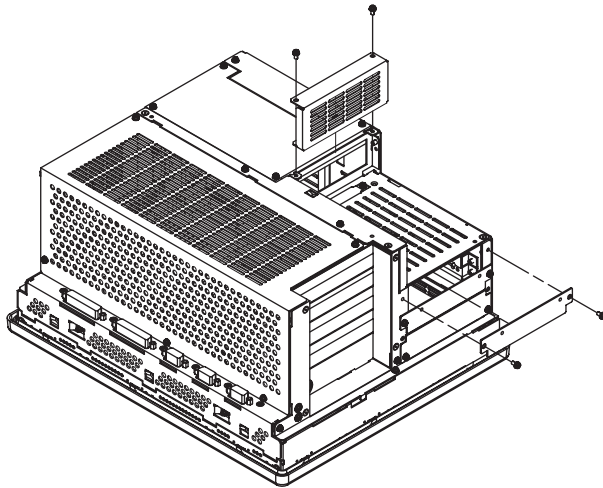

- 1) Unscrew the IDE I/F cover's two (2) attachment screws and the HDD1 slot's two (2) attachment screws. Remove the IDE I/F cover and the HDD1 slot cover.

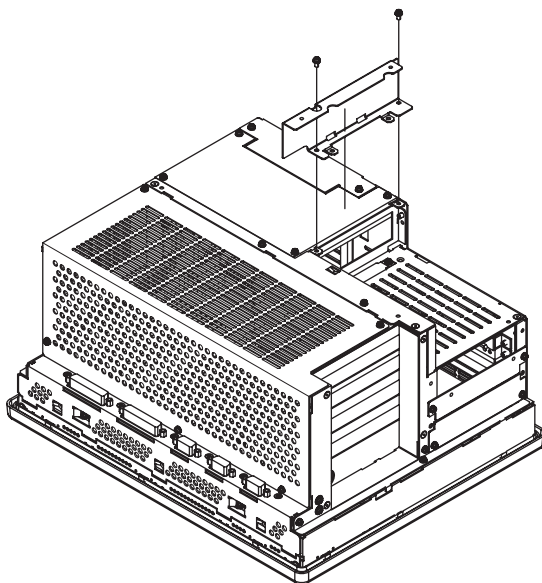

- 2) Secure PL fastener (C) to the rear of the PL unit using the two (2) attachment screws.

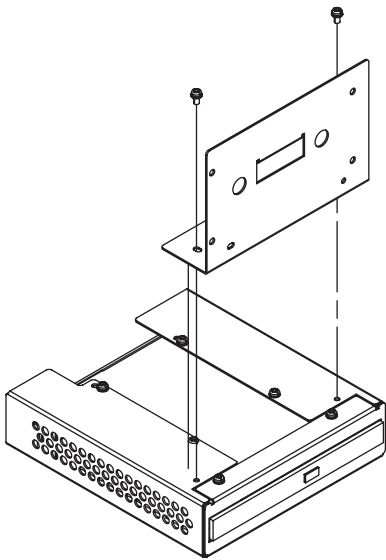

- 3) Secure PL fastener (D) to the PSS-CD01 unit using the two (2) attachment screws.

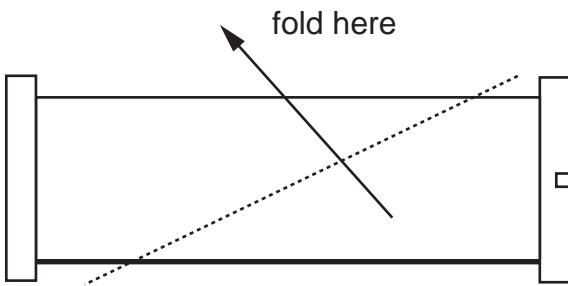

- 4) As shown in the left-side figure, fold the cable over, along the dotted line.

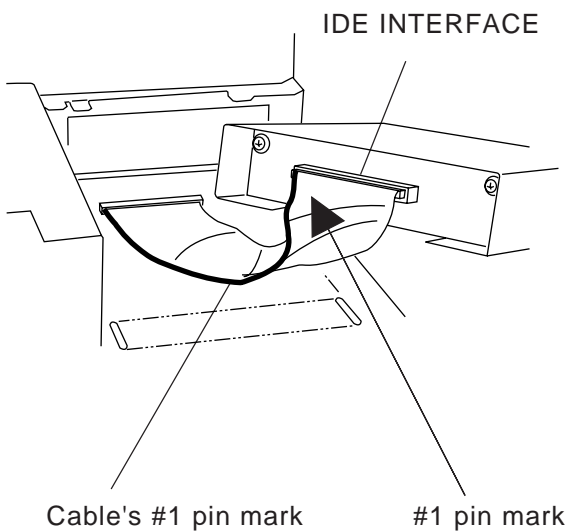

- 5) Connect the PSS-CD01 unit to the PL unit via the connection cable. Be sure to confirm that the Cable's #1 pin mark and the connector are correctly aligned.

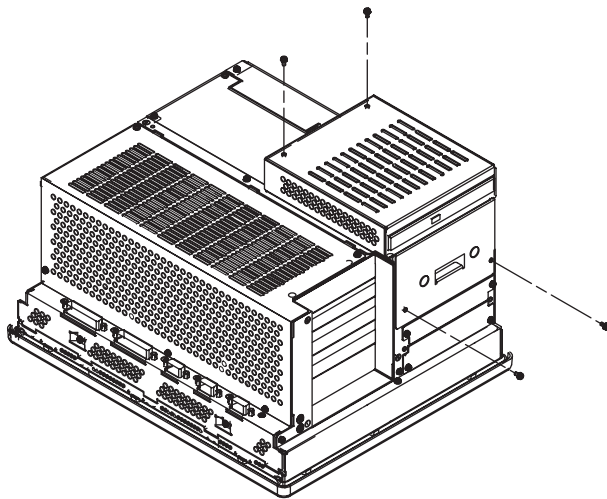

- 6) Secure the PSS-CD01 unit to the PL unit using the four (4) attachment screws. Place the cable in the space between the PSS-CD01 and the PL unit.



To be sure to prevent the cable from being caught between the PL unit and PSS-CD01 and possibly damaged.



CAUTION

Refer to the following drawings to confirm that the connection cable is securely attached to both connectors. Be sure to check both connectors before turning the PL ON, since incorrect attachment of the connectors can cause equipment damage.

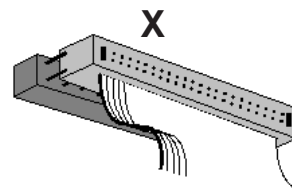
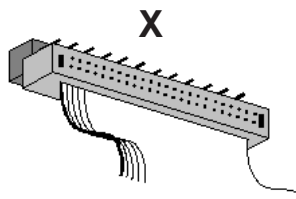

Note

Please be aware that Digital Electronics Corporation shall not be held liable by the user for any damages, losses, or third party claims arising from the uses of this product.

Digital Electronics Corporation

8-2-52 Nanko Higashi, Suminoe-ku, Osaka 559-0031, Japan

URL: <http://www.pro-face.com/>

© 2004 Digital Electronics Corporation All rights reserved.