

Magnetic Level Gauge Type 810



Essential Instructions

Read this page before proceeding!

Brooks Instrument designs, manufactures and tests its products to meet many national and international standards. Because these instruments are sophisticated technical products, you must properly install, use and maintain them to ensure they continue to operate within their normal specifications. The following instructions must be adhered to and integrated into your safety program when installing, using and maintaining Brooks Products.

- Read all instructions prior to installing, operating and servicing the product. If this instruction manual is not the correct manual, please see back cover for local sales office contact information. Save this instruction manual for future reference.
- If you do not understand any of the instructions, contact your Brooks Instrument representative for clarification.
- Follow all warnings, cautions and instructions marked on and supplied with the product.
- Inform and educate your personnel in the proper installation, operation and maintenance of the product.
- Install your equipment as specified in the installation instructions of the appropriate instruction manual and per applicable local and national codes. Connect all products to the proper electrical and pressure sources.
- To ensure proper performance, use qualified personnel to install, operate, update, program and maintain the product.
- When replacement parts are required, ensure that qualified people use replacement parts specified by Brooks Instrument. Unauthorized parts and procedures can affect the product's performance and place the safe operation of your process at risk. Look-alike substitutions may result in fire, electrical hazards or improper operation.
- Ensure that all equipment doors are closed and protective covers are in place, except when maintenance is being performed by qualified persons, to prevent electrical shock and personal injury.

Pressure Equipment Directive (PED)

All pressure equipment with an internal pressure greater than 0.5 bar (g) falls under the Pressure Equipment Directive (PED). The Directive is applicable within the European Economic Area (EU plus Norway, Iceland and Liechtenstein). Pressure equipment can be traded freely within this area once the PED has been complied with.

- Section 1 of this manual contains important safety and operating instructions related to the PED directive.
- Devices described in this manual are in compliance with EN directive 97/23/EC module H *Conformity Assessment*.
- Brooks Instrument Magnetic Level gauges can be used with fluid group 1 or group 2.
- Design pressure and instrument volume will give a coefficient (P x V). According (P x V) coefficient and fluid group, instruments are designed to be in compliance with SEP or Categories I, II, III IV of the Directive.

ESD (Electrostatic Discharge)

CAUTION

This instrument contains electronic components that are susceptible to damage by static electricity. Proper handling procedures must be observed during the removal, installation or other handling of circuit boards or devices.

Handling Procedure:

1. Power to unit must be removed.
2. Personnel must be grounded, via a wrist strap or other safe, suitable means before any printed circuit card or other internal device is installed, removed or adjusted.
3. Printed circuit cards must be transported in a conductive container. Boards must not be removed from protective enclosure until immediately before installation. Removed boards must immediately be placed in protective container for transport, storage or return to factory.

Comments

This instrument is not unique in its content of ESD (electrostatic discharge) sensitive components. Most modern electronic designs contain components that utilize metal oxide technology (NMOS, SMOS, etc.). Experience has proven that even small amounts of static electricity can damage or destroy these devices. Damaged components, even though they appear to function properly, exhibit early failure.

Installation and Operation Manual

X-VA-MLG-810-eng

Part Number: 541B256AAG

January, 2009

Brooks® Magnetic Level Gauge

Dear Customer,

We appreciate this opportunity to service your level measurement and control requirements with a Brooks Instrument device. Every day, level customers all over the world turn to Brooks Instrument for solutions to their liquid level applications. Brooks provides an array of flow measurement and control and level products for various industries from biopharmaceuticals, oil and gas, fuel cell research and chemicals, to medical devices, analytical instrumentation, semiconductor manufacturing, and more.

The Brooks product you have just received is of the highest quality available, offering superior performance, reliability and value to the user. It is designed with the ever changing process conditions, accuracy requirements and hostile process environments in mind to provide you with a lifetime of dependable service.

We recommend that you read this manual in its entirety. Should you require any additional information concerning Brooks products and services, please contact your local Brooks Sales and Service Office listed on the back cover of this manual or visit www.BrooksInstrument.com

Yours sincerely,

Brooks Instrument

Brooks® Magnetic Level Gauge

Instrument Markings
 and Their Locations
 on the Instrument



Brooks Instrument S.A.S. ZA DE LA TOUR 03200 ABREST-FRANCE
BOITIER TYPE B4 Made in France
 WARNING: DO NOT OPEN WHILE ENERGIZED. Tank
 AVERTISSEMENT: PAS OUVRIRE SOUS TENSION. -60°C to 60°C
 N° DE SERIE SERIAL N° ANNEE YEAR
 REPERE TAG
 Umax=230V Imax=15A Pmax=20W
 CE 0081 IIC6 Exd IIC16 LCIE0ATEX6060X

TYPE: N° DE SERIE SERIAL N°
 PRESSION p₀max P₁test DATE
 PRESSE P₀max P₁test
 VOL. L DN TEMPERATURE MAX °C MIN °C
 GAZ gr-1 gr-2 densité ANNEE YEAR
 LIQ gr-1 gr-2 S.G.
 REPERE TAG
 BROOKS Cet équipement est construit en accord avec la Directive 97/23/CE, Article 3.3
 INSTRUMENTS Brooks Instrument S.A.S. ZA DE LA TOUR 03200 ABREST VICHY FRANCE

TYPE: N° DE SERIE SERIAL N°
 PRESSION p₀max P₁test DATE
 PRESSE P₀max P₁test
 VOL. L DN TEMPERATURE MAX °C MIN °C
 GAZ gr-1 gr-2 densité ANNEE YEAR
 LIQ gr-1 gr-2 S.G.
 REPERE TAG
 BROOKS CE

TYPE: N° DE SERIE SERIAL N°
 PRESSION p₀max P₁test DATE
 PRESSE P₀max P₁test
 VOL. L DN TEMPERATURE MAX °C MIN °C
 GAZ gr-1 gr-2 densité ANNEE YEAR
 LIQ gr-1 gr-2 S.G.
 REPERE TAG
 BROOKS CE0060

Brooks Instrument SAS TYPE Scw/Bar T °C
 ZA DE LA TOUR N°SERIE/serial Test/Bar
 03200 ABREST-FRANCE REPERE/tag d/Sg

Handling Precautions



Do not move by yourself!

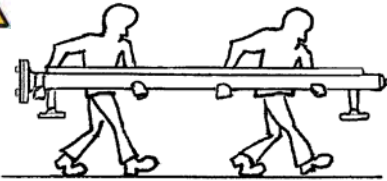

Handle Carefully at All Times!

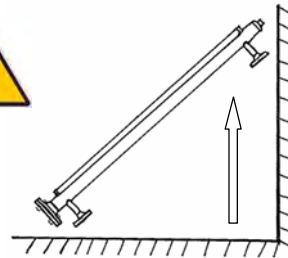

Do Not Drop!



Do Not Shock! Internal Glass Parts

Identification Number
 is needed when any
 request or claim is
 given to our
 Technical or Sales
 Departments

<u>Paragraph Number</u>	<u>Page Number</u>
Introduction Section 1	
1-1 Principle	1-1
1-2 Description	1-2
1-3 Specification	1-3
1-3-1 Standard Version Types 810	1-4
1-3-2 Standard Version Types 811 Top Mounting	1-5
Installation Section 2	
2-1 General	2-1
2-2 Receipt of Equipment	2-1
2-3 Recommended Storage Practice	2-2
2-4 Return Shipment	2-2
2-5 Transit Precautions	2-3
2-6 Removal from Storage	2-3
2-7 High/Low Temperature Processes	2-3
2-8 Commissioning	2-4
2-9 Instruction Specific to Hazardous Area Installations	2-5
2-9-1 Explosion-Proof Version	2-5
2-9-2 Transmitter Version	2-6
2-10 Fitting	2-7
Operation Section 3	
3-1 Safety with Regards to Pressure	3-1
3-2 Checking for Correct Operation	3-1
3-3 Maintenance	3-1
3-4 Wiring and Use of Alarms	3-2
3-5 Location	3-3
3-6 Wiring	3-3
Maintenance Section 4	
4-1 Damaged Float Indicator / Initialization	4-1
4-2 Glass Tube Replacement	4-3
4-3 Slider Replacement	4-4
4-4 Flaps/Rollers Indicator Replacement	4-4
4-5 Float Replacement	4-5
Parts List Section 5	
5-1 Spare Parts List	5-1
Warranty, Local Sales/Service Contact Information	Back Cover

Figures

Brooks® Magnetic Level Gauge

<u>Figure Number</u>	<u>Page Number</u>
1-1 Indicator Types	1-1
1-2 Level Gauge Components	1-2
1-3 Side Mounting	1-4
1-4 Top Mounting	1-5
2-1 Torque Patterns	2-4
3-1 Typical Alarm Housings	3-2
3-2 Alarm Location	3-3
4-1 Resetting the Indicator Flaps or Rollers	4-2
4-2 Locking Clamps	4-3
4-3 Connecting Sleeve	4-3
4-4 Manufacturer Plate Location	4-4
4-5 Alignment of Indicator to Gauge	4-4
4-6 Location of Float Limit Stop	4-5

Tables

<u>Table Number</u>	<u>Page Number</u>
3-1 Maximum Current	3-2

1-1 Principle

The magnetic level indicator directly measures liquid levels, even corrosive or dangerous, into vessels or under pressurized tanks. The design of this equipment ensures a good accuracy, an excellent reliability and a safe use.

A float equipped with a permanent magnet follows the level variation of liquid to be measured.

- **Slider version:** the float drives a magnetic slider which slides into a Pyrex tube mounted on a graduated scale. (See Figure 1-1).
- **Rollers version:** the float reverses magnetically locked bi-colored rollers. The red zone indicates the level of liquid in the tank. (See Figure 1-1).
- **Flaps version:** the float reverses magnetically locked bi-colored aluminium flaps. The red zone indicates the level of liquid in the tank. For high and low temperatures processes. (See Figure 1-1).

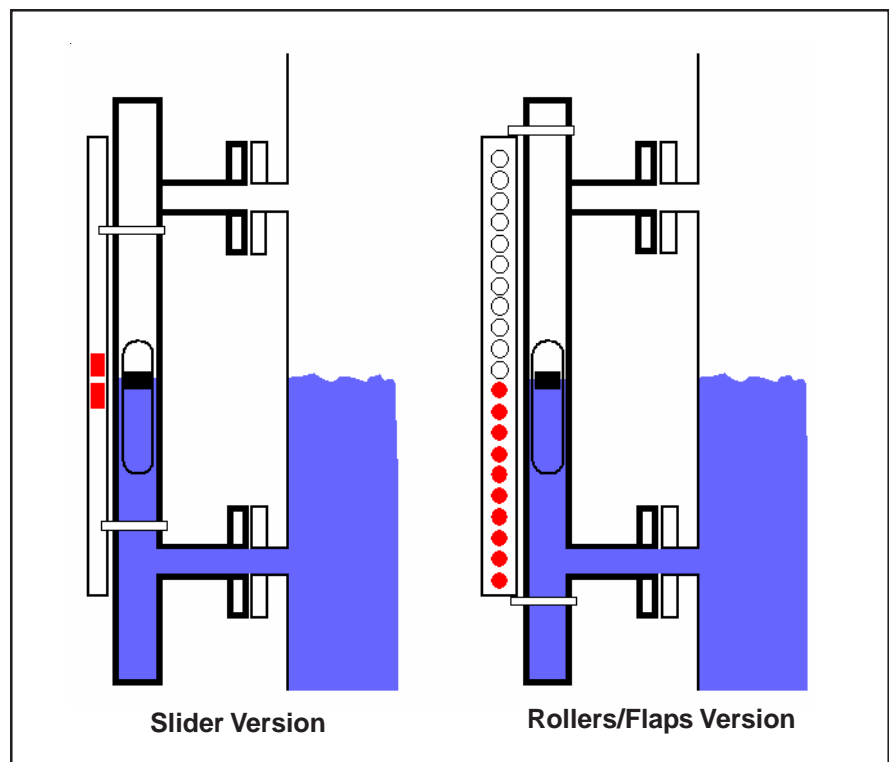



Figure 1-1 Indicator Types

Brooks® Magnetic Level Gauge

	<p>⚠ WARNING</p> <p>METER/CONTROLLER SEAL COMPATIBILITY</p>
<p>Products in this manual may contain metal or elastomeric seals, gaskets, O-rings or valve seats. It is the "user's" responsibility to select materials that are compatible with their process and process conditions. Using materials that are not compatible with the process or process conditions could result in the Meter or Controller leaking process fluid outside the pressure boundary of the device, resulting in personnel injury or death.</p> <p>It is recommended that the user check the Meter or Controller on a regular schedule to ensure that it is leak free as both metal and elastomeric seals, gaskets, O-rings and valve seats may change with age, exposure to process fluid, temperature, and /or pressure.</p>	

1-2 Description

The equipment consists of two separate parts which are the measuring float chamber and the reading system.

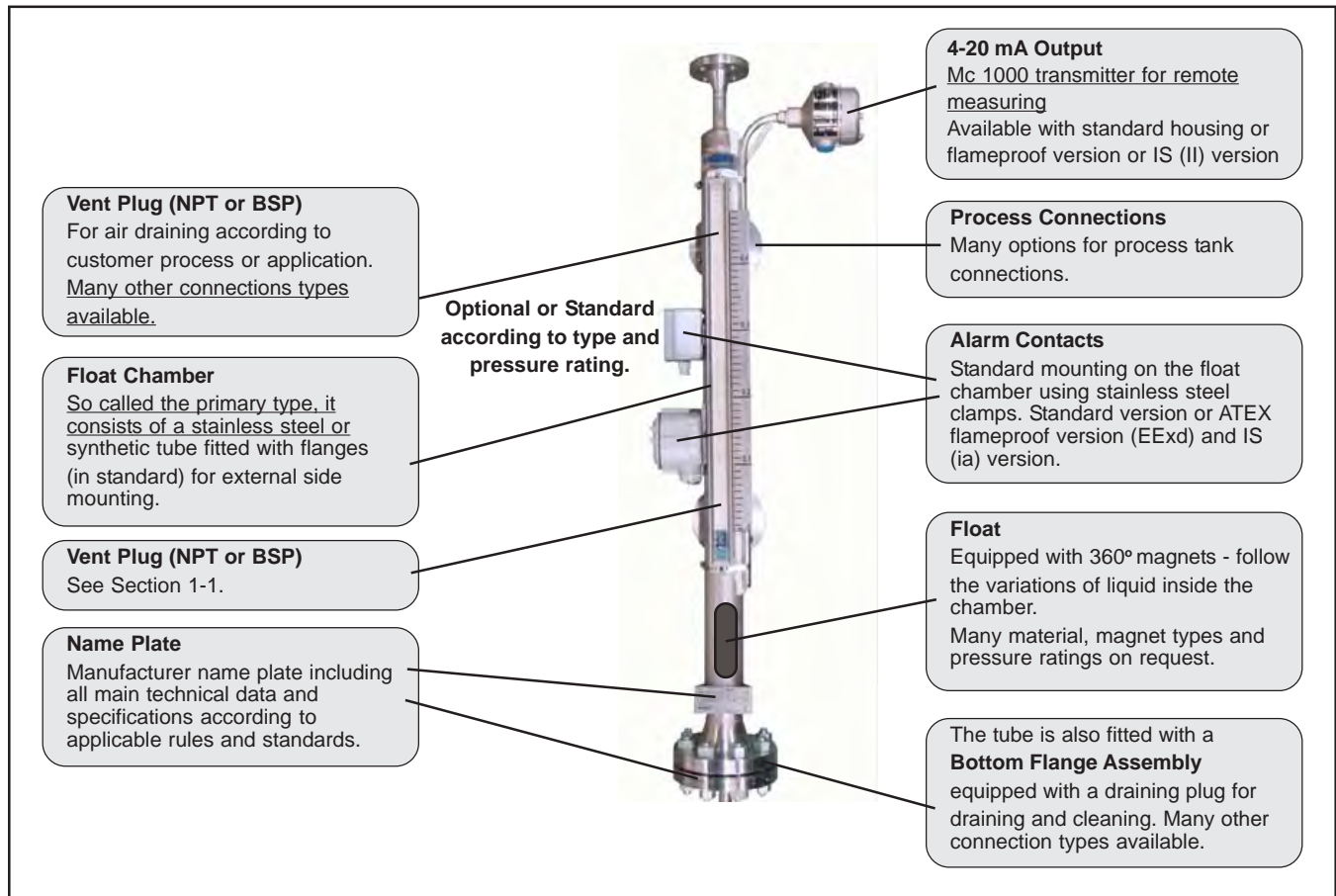

1-2 Figure 1-2 Level Gauge Components

1-3 Specifications

CAUTION

It is the user's responsibility to select and approve all materials of construction. Careful attention to metallurgy, engineered materials and elastomeric materials is critical to safe operation.

WARNING

Do not operate this instrument in excess of the specifications listed below. Failure to heed this warning can result in serious personal injury and/or damage to the equipment.

Pressure Equipment Directive (PED) 97/23/EC

Brooks Magnetic level Gauges can be used with Fluid Groups 1 and 2. Design pressure and instrument volume will give a coefficient (P×V). According (P × V) coefficient and fluid group, instruments are designed to be in compliance with (SEP) or Categories I, II, III and IV of the Directive.

Magnetic Level Gauges types 810-811 are designed to be either top or side mounted. Considering these two standard possibilities, the principle is still the same, only the design change. Any other special mountings or processes could be considered on request.

Brooks® Magnetic Level Gauge

1-3-1 Standard Version Types 810 - Side Mounting

- **Center to center** : 0.3 m min. / 5.5m is standard with 1 section.
Longer center to center is available with multiple section construction.
- **Connections**
Stainless Steel chamber:
ANSI, ISO flanges, half couplings and Tubes
PVC-U, PPH, PVDF Chambers:
Loose flanges PN10, DN25 or 1" ISO, ANSI flanges
- **Specific gravities:**
St. Steel chambers S.G. = 0.4 minimum
PVC-U, PPH, PVDF Chambers S.G.=0,9 minimum
- **Operating pressure** (at ambient Temperature)
St. Steel chambers : acc. to design up to 400 bar
PVC-U, PPH, PVDF chambers: 10 bar max., 6 bar with Fluid Group 1
- **Maximum temperature**
St. Steel chambers: up to 350°C w/ insulation
PVC-U chambers : 60°C at atm pressure
PPH chambers : 80°C at atm pressure
PVDF chambers : 130°C at atm pressure

NOTE: Do not heat-protect the indicators.

- **Viscosity** 100 Cp max.

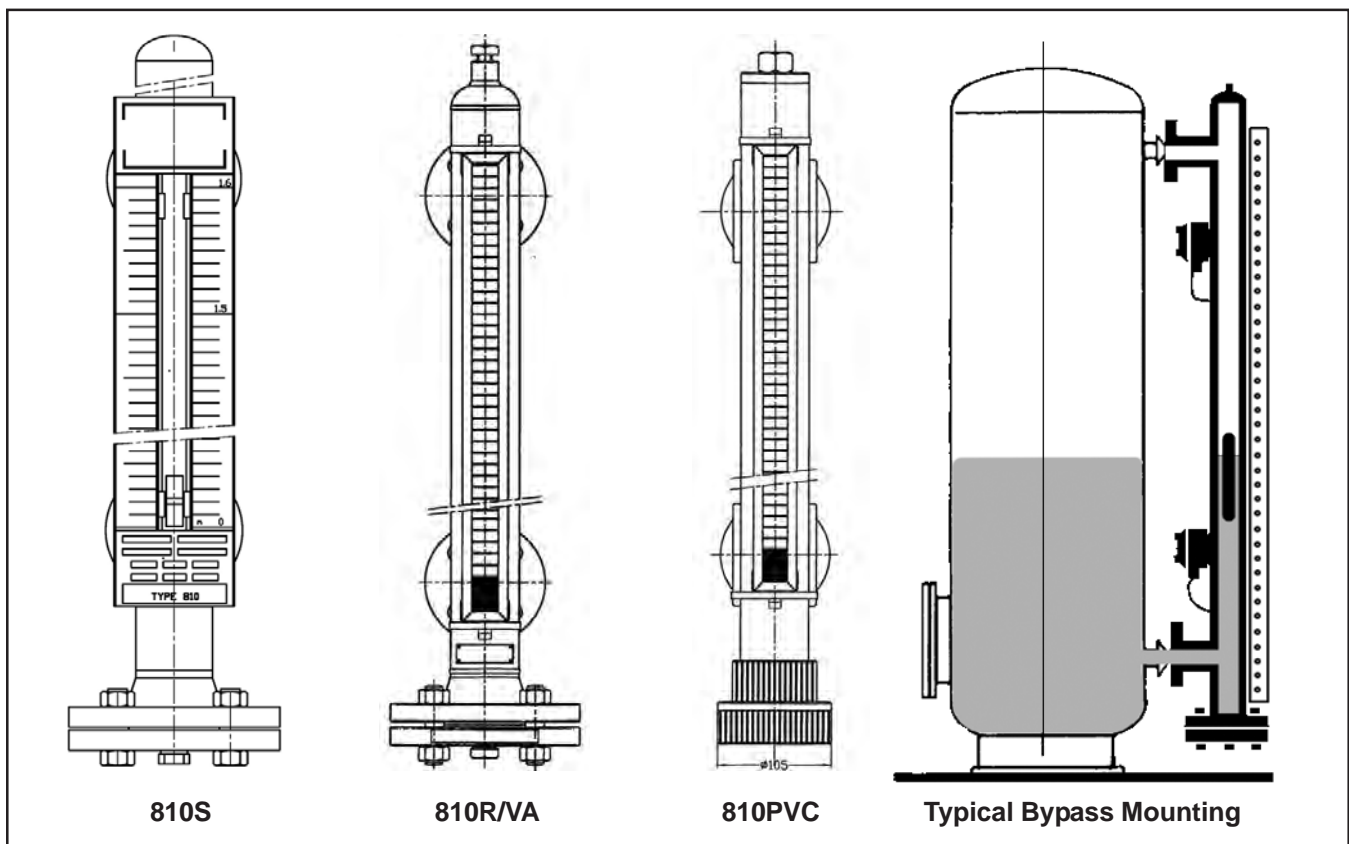

1-4 Figure 1-3 Side Mounting

1-3-2 Version Types 811 - Top Mounting

The bottom dead band (BMB) and/or the top dead band (BMH) are directly depending of the ratio level/ specific gravity and the pressure.

- L max : 117" (3m)
- Operation pressure with standard stainless steel Float 3 bar (max. 12 bar)
- Flanges > DN65 / PN16 or ANSI 150#
- Others connection types or spec on request

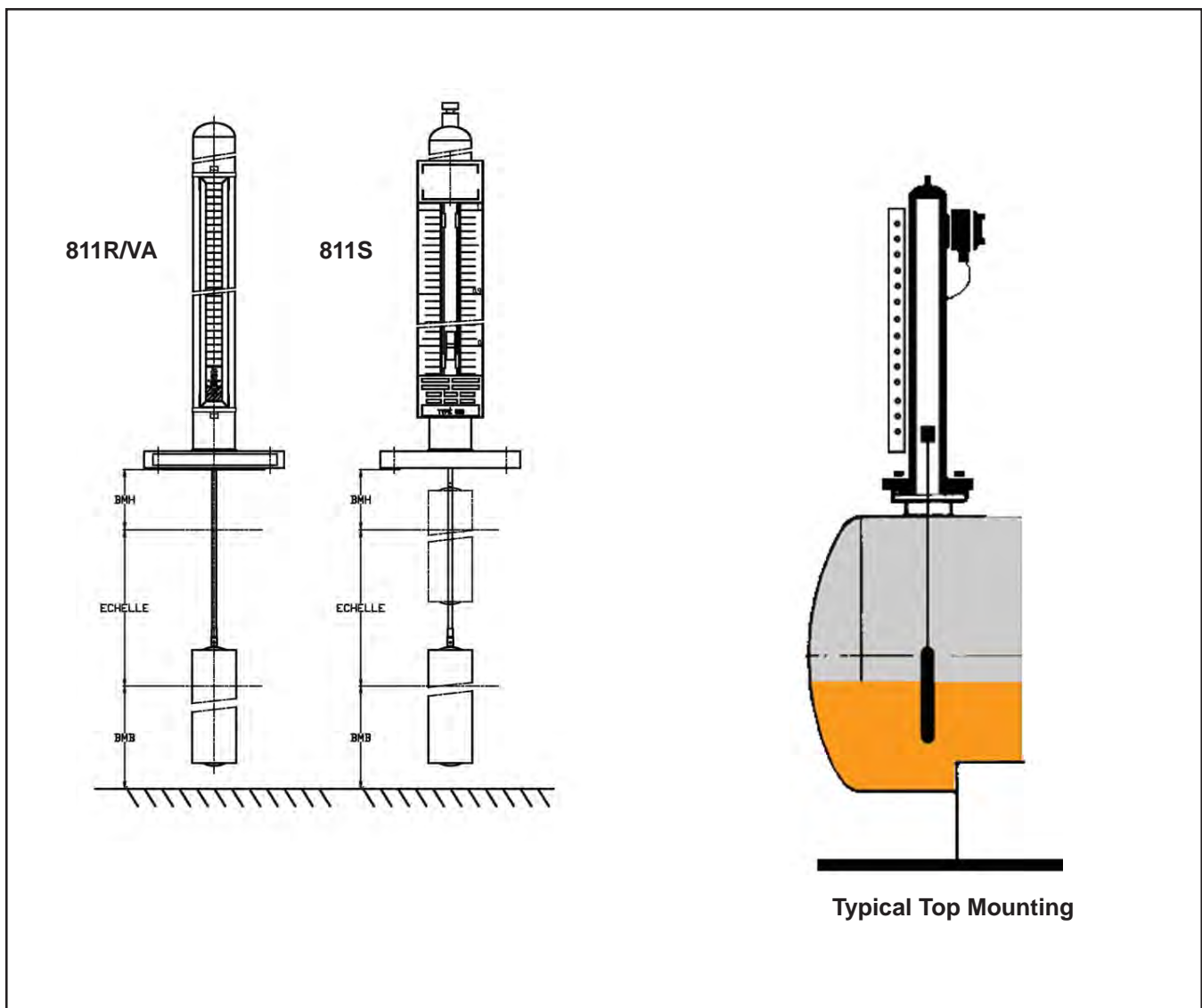

Figure 1-4 Top Mounting

Brooks® Magnetic Level Gauge

*THIS PAGE WAS
INTENTIONALLY
LEFT BLANK*

2-1 General

This equipment must only be handled empty, with all essential precautions taken to avoid impact or major stresses, which would be likely to alter its geometry and damage internal measuring devices, or the contact pattern of the connecting component seals.

The various parts must be installed without mechanical or other stresses, other than those provided for when installing the equipment, and sealing the connection. Under no circumstances must the equipment be used as a support or for mounting any part or component not originally provided for.

Welding is prohibited. If welded connections or fastenings are required by the equipment definition, these must be produced by qualified personnel, using recognized operating procedures and the required materials, meeting current standards.

Grinding, cutting or heating are prohibited on any parts of the equipment which are subject to pressure.

Make the connections using seals suitable for the fluid contained and the type of connection required. For flanges, make sure the seals used are new, compatible with the seal contact pattern and the service pressure and temperature. Use standard fastenings which match the flange rating and service conditions required by the type of seal and the process.

2-2 Receipt of Equipment

When the instrument is received, the outside packing case should be checked for damage incurred during shipment. If the packing case is damaged, the local carrier should be notified at once regarding his liability. A report should be submitted to your nearest Product Service Department.

Brooks Instrument
407 W. Vine Street
P.O. Box 903
Hatfield, PA 19440 USA
Toll Free (888) 554 FLOW (3569)
Tel (215) 362 3700
Fax (215) 362 3745
E-mail: BrooksAm@BrooksInstrument.com
www.BrooksInstrument.com

Brooks Instrument
Neonstraat 3
6718 WX Ede, Netherlands
P.O. Box 428
6710 BK Ede, Netherlands
Tel +31 (0) 318 549 300
Fax +31 (0) 318 549 309
E-mail: BrooksEu@BrooksInstrument.com

Brooks Instrument
1-4-4 Kitasuna Koto-Ku
Tokyo, 136-0073 Japan
Tel +81 (0) 3 5633 7100
Fax +81 (0) 3 5633 7101
Email: BrooksAs@BrooksInstrument.com

Brooks Instrument
Zones d' Activités de la Tour
03200 ABREST (Rive Gauche)
BP 2438 03204 VICHY Cedex France
T +33 (0) 4 70 59 81 81
F +33 (0) 4 70 59 96 37
Email: BrooksSAS@BrooksInstrument.com

Remove the envelope containing the packing list. Carefully remove the instrument from the packing case. Make sure spare parts are not discarded with the packing materials. Inspect for damaged or missing parts.

Brooks® Magnetic Level Gauge

2-3 Recommended Storage Practice and Prior Conditions

In case of storage we recommend to keep the instrument in its original packing and in the suitable conditions until the installation.

Ensure that all safety regulations are observed, in particular those relating to hazardous areas. As far as inherent safety is concerned, check that the classification of the instrument corresponds to the classification required at the installation site.

If intermediate or long-term storage of equipment is required, it is recommended that the equipment be stored in accordance with the following:

- Within the original shipping container.
- Stored in a sheltered area, preferably a warm, dry, heated warehouse.
- Ambient temperature of 70° F (21° C) nominal, 109° F (43° C) maximum, 45° F (7° C) minimum.
- Relative humidity 45% nominal, 60% maximum, 25% minimum.

Upon removal from storage a visual inspection should be conducted to verify the condition of equipment is "as received".

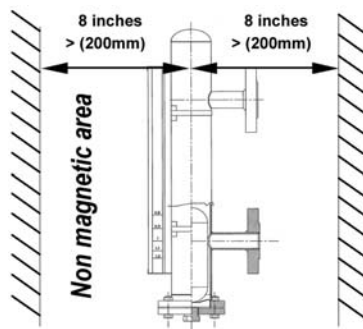

⚠ CAUTION

In order not to disturb the magnetic coupling, an area of about 8 inches (200mm) free from any magnetic component, must be provided surrounding the indicator unit extension.

2-4 Return Shipment

Prior to returning any instrument to the factory, contact your nearest Brooks location for a Return Materials Authorization Number (RMA#). This can be obtained from one of the following locations:

Brooks Instrument
 407 W. Vine Street
 P.O. Box 903
 Hatfield, PA 19440 USA
 Toll Free (888) 554 FLOW (3569)
 Tel (215) 362 3700
 Fax (215) 362 3745
 E-mail: BrooksAm@BrooksInstrument.com
 www.BrooksInstrument.com

Brooks Instrument
 1-4-4 Kitasuna Koto-Ku
 Tokyo, 136-0073 Japan
 Tel +81 (0) 3 5633 7100
 Fax +81 (0) 3 5633 7101
 Email: BrooksAs@BrooksInstrument.com

Brooks Instrument
 Neonstraat 3
 6718 WX Ede, Netherlands
 P.O. Box 428
 6710 BK Ede, Netherlands
 Tel 31-318-549-300
 Fax 31-318-549-309
 E-mail: BrooksEu@BrooksInstrument.com

Brooks Instrument
 Zones d' Activités de la Tour
 03200 ABREST (Rive Gauche)
 BP 2438 03204 VICHY Cedex France
 T +33 (0) 4 70 59 81 81
 F +33 (0) 4 70 59 96 37
 Email: BrooksSAS@BrooksInstrument.com

The instrument must have been purged in accordance with the following:

All flow and level instruments returned to Brooks requires completion of Form RPR003-1, Brooks Instrument Decontamination Statement, along with a Material Safety Data Sheet (MSDS) for the fluid(s) used in the instrument. Failure to provide this information will delay processing by Brooks personnel. Copies of these forms can be downloaded from the Brooks website www.BrooksInstrument.com or are available from any Brooks Instrument location listed above.

2-5 Transit Precautions

To safeguard against damage during transit, transport the instrument to the installation site in the same container used for transportation from the factory if circumstances permit.

2-6 Removal From Storage

Upon removal of the instrument from storage, a visual inspection should be conducted to verify its "as-received" condition. If the instrument has been subject to storage conditions in excess of those recommended it should be subjected to a pneumatic pressure test in accordance with applicable vessel codes.

2-7 High/Low Temperature Processes

- For heat-protected instruments the indicator (flaps or slider housing) must be free from any heat protection.
- take precautions to slide the heat shield stripe too.
- For very low temperatures processes, heat protection should be applied up the external face of the anti-frost option window.

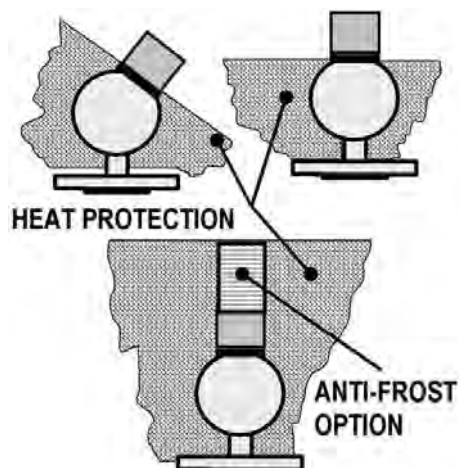

Brooks® Magnetic Level Gauge

2-8 Commissioning

- Following the receipt and before mounting, check first if the float is not locked in the lower part of the equipment body by a wood or plastic rod, inserted in the lower connection pipe. If existing remove this rod and check that the float moves freely in the chamber before erecting.
- Prior to operating the unit, make sure that the lines have been bled and that they are free from any solid particles (metallic or non metallic particles). The instrument must be mounted 100% vertically. Gradually build up the pressure while checking that it does not exceed the maximum operating pressure rated for the unit.
- During the commissioning make sure that the magnetic slider follows the level changes. If necessary, magnetically couple the follower to the float, by performing a bleeding operation followed by a new filling operation.
- Ensure that the rated dimensions of the coupling flanges match those of the instrument and that the pipes are sufficiently rigid and properly secured in order to prevent vibration being transmitted to the instrument.
- After verifying the condition of the seal contact pattern, tighten the bolts in several stages (shown below), using appropriate tools, torque or pneumatic wrench and respecting the torque settings recommended by the seal manufacturer.

Run a tightness test under service conditions before commissioning the equipment.

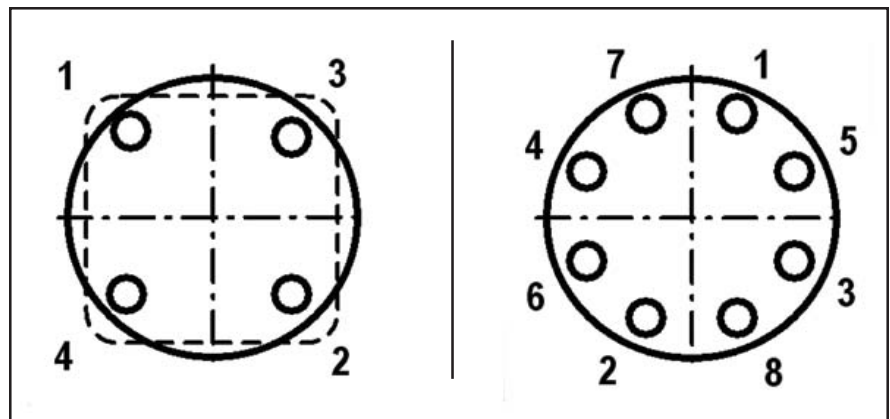

Figure 2-1 Torque Patterns

2-9 Instructions Specific to Hazardous Area Installations

2-9-1 Explosion-Proof Version

(Apply to the flame-proof detection box type B4: certificate number LCIE01ATEX6060X) (S2/S4 option)

BEFORE ANY INTERVENTION ON THE INSTRUMENT, USUAL PRECAUTIONS SHOULD BE TAKEN.

⚠ CAUTION

Power supply should be switched off before any intervention. Flame-Proof housing must not be opened while energized.

- Always refer to the safety specifications instructions of the installation place and more particularly with regard to the hazardous zones as well as the dangerous products.
- The level switch or transmitter can be used with flammable gases and vapors belonging to groups IIA, IIB and IIC and temperatures class of T6.
- The installation of the instrument must be carried out by personnel in conformity with the local installation standards.
- The customer has the responsibility that the instrument specifications are appropriate for the process condition and application specifications.

⚠ CAUTION

For instrument installations, read ATEX "Safety Instructions for Detection Box Type B4".



Brooks® Magnetic Level Gauge

2-9-2 Transmitter Version

(APPLY TO THE I.S. CERTIFICATE : LCIE 05ATEX6034X)

BEFORE ANY INTERVENTION ON THE INSTRUMENT, USUAL PRECAUTIONS SHOULD BE TAKEN.

- Always refer to the safety specifications instructions of the installation place and more particularly with regard to the hazardous zones as well as the dangerous products.
- The level switch or transmitter can be used with flammable gases and vapors belonging to groups IIA, IIB and IIC and temperatures class of T6, T5 or T4.
- The installation of the instrument must be carried out by personnel in conformity with the local installation standards.
- The customer has the responsibility that the instrument specifications are appropriate for the process condition and application specifications.

⚠ CAUTION

For intrinsically safe instruments which may be installed in hazardous areas, read ATEX "Safety Instructions for Detection Box Type B5".

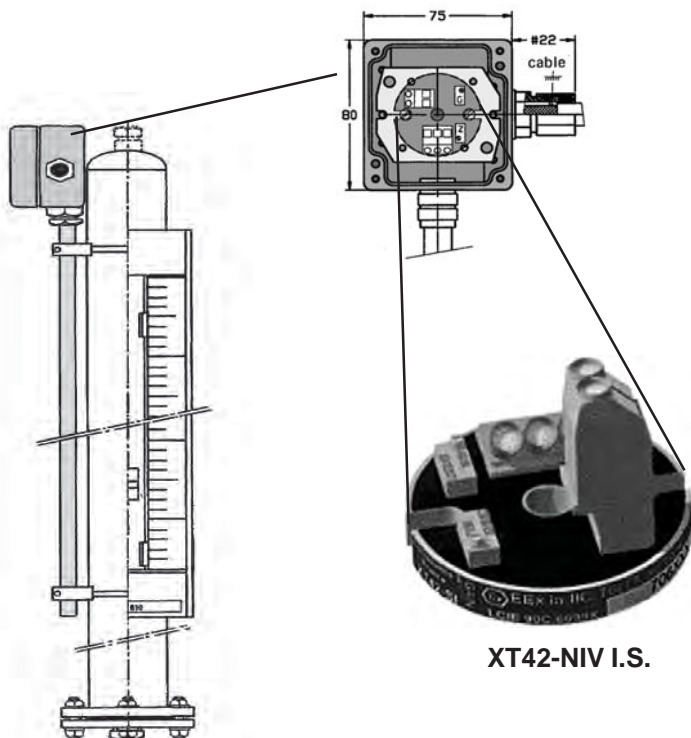

2-10 Fitting

- Install the instrument into the pipe work/on the tank, inserting appropriate seals (not supplied) between the flanges. Ensure that the coupling flanges are parallel to those on the instrument and that the distance between centers is suitable in order to avoid strain other than that needed to provide sealing.
- Tighten the bolts to obtain a sealed joint (retighten after a period of operation if necessary). When fitting the instrument with PTFE lining, special precautions must be taken as PTFE is readily distorted when cold; the recommended tightening torques below should not be exceeded:

1/2" / DN15: 10Nm 3/4" / DN20: 20Nm
2" / DN50: 40Nm 3" / DN80: 50Nm

Important note: The PTFE gasket must have the same dimensions than the level gauge flange raised face and perfectly centered before tightening.

⚠ WARNING

ESSENTIAL SAFETY REQUIREMENTS

- **Instruments must be mounted vertically in rigid fixed pipelines/tank connections.**
- **Care must be taken to avoid inducing torsion stress on the instrument when installing on the vessel.**
- **Prior to installation ensure the pipelines are flushed and drained to ensure they are free from any solid particles and pressure.**
- **Valves must be opened or closed progressively to avoid shock/vibration.**
- **Do not exceed maximum working pressure as stated on the instrument Name Plate.**
- **Only use with the fluid/gas stated on the instrument label.**
- **Solvents must not be used to clean the protective flaps box cover.**
- **Do not exceed minimum/maximum working temperature as stated in this manual.**
- **For heat-protected instruments, indicator must not be covered with any heat protection. Check regularly for its correct status. Periodically the indicator will need replacement.**
- **Do not subject the meter to any sudden or extreme changes in temperature .**
- **The instrument must be regularly checked for corrosion and wear.**

Brooks® Magnetic Level Gauge

*THIS PAGE WAS
INTENTIONALLY
LEFT BLANK*

3-1 Safety with Regards to Pressure

CAUTION

Any sudden change in system pressure may cause mechanical damage to elastomer materials. Damage can occur when there is a rapid expansion of fluid that has permeated elastomer materials. The user must take the necessary precautions to avoid such conditions.

This pressurized equipment is part of a unit, so the customer must fit the installation with safety devices (valves, rupture disk, sensor,...) to protect the equipment against the risk of excess pressure. The opening pressure of these devices must equal the maximum allowable pressure (PS) of the equipment. These mechanisms must also allow evacuation of full-flow steam under rated calculated conditions. The vent must be piped freely and without danger to personnel or the environment. The integrator must also provide a device for measuring residual pressure in the equipment (pressure gauge ...) and a bleeder (piped if the product so requires), to guarantee the safety of personnel working on the equipment.

Isolation valves are recommended to be installed between the equipment and the unit to which it is mounted, so that maintenance operations can be performed. Any other way (or design) may be achieved if they provide a acceptable safety level in accordance with the Directive 97/23/EC and/or present standards

3-2 Checking for Correct Operation

The operator should periodically verify the equipment's ability to continue in service. Periodic monitoring and inspections must be made in accordance with current regulations in the country in which the equipment is used.

3-3 Maintenance

This instrument is maintenance-free during normal operation. However, it should be cleaned at regular intervals if it is used with fluids that contain sediment or other deposits.

CAUTION

Before fully withdrawing the instrument from the tank, it is advisable to check that the indicator is operating correctly.

Brooks® Magnetic Level Gauge

3-4 Wiring and Use of Alarms

Installation of the instruments contacts will be carried out by trained personnel in conformity with the local installation standards.

Each level gauge could be equipped with alarm contacts. Fitted along the main tube, they are adjusted to switch on as the level rise to the chosen level of liquid.

The contact housing is IP65 in standard ATEX flame-proof (EExd) or I.S. (ia) on request.



Standard Housing	Flame-Proof Housing	Contact with Cable
		
<ul style="list-style-type: none"> • Light alloy material housing IP65 • wiring connection using contact screwed terminal. • dimensions 80x75x57mm • Output connection using one or two PG9 synthetic cable gland(s) (diam 5-9mm). • S1, S3, S6, S7 Models • ATEX "ia" certified • II 1/2 G Exia IIC T6 LCIE05ATEX6034X (See Table 3-1) 	<ul style="list-style-type: none"> • Light alloy material housing IP66 • Output connection using a flame-proof 3/4NPT cable gland for (diam 5-12mm electrical cable). • ATEX conformity • II 2G Exd IIC T6 LCIE01ATEX6060X w S2, S4 Models (See Table 3-1) 	<ul style="list-style-type: none"> • Direct mounting • Fitted with a 3meters electric cable • Sealing protection IP65 • Dimensions : 75x15x15mmw -20°C < T < 80°C S5 Model
<p>Electrical Characteristics: Maximum Voltage 220VAC/110DC</p>		

Figure 3-1 Typical Alarm Housings

Table 3-1 Maximum Current

VOLTAGE		MAX. CURRENT
AC	DC	
230V	----	0.25A
110V	----	0.55A
----	48V	1A
----	24V	1A

3-5 Location

In order to make easier operations on instruments alarm contacts, housing should be fitted as near as possible to the flaps/ slider housing (See Figure 3-2). Position has no effect on signal quality.

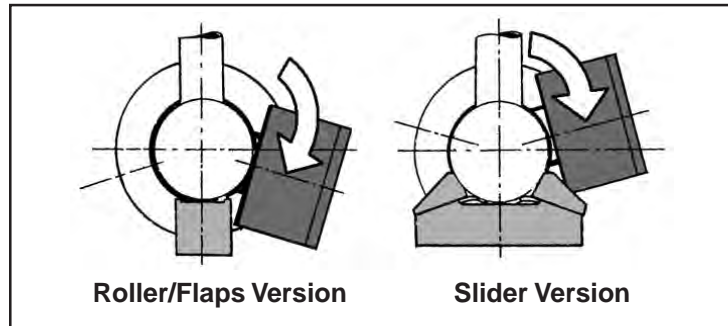
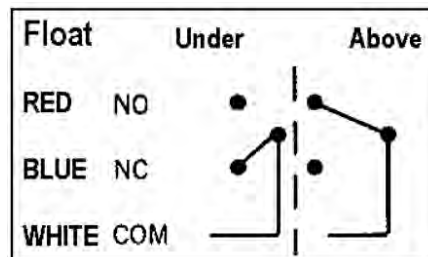

Figure 3-2 Alarm Location

3-6 Wiring

During the wiring procedure, refer to electrical and technical characteristics specified on instrument contact label located under the electrical terminal box (see diagram below)



Brooks® Magnetic Level Gauge

*THIS PAGE WAS
INTENTIONALLY
LEFT BLANK*

4-1 Damaged Float Indicator / Initialization

	⚠ WARNING
METER/CONTROLLER SEAL COMPATIBILITY	
<p>Products in this manual may contain metal or elastomeric seals, gaskets, O-rings or valve seats. It is the "user's" responsibility to select materials that are compatible with their process and process conditions. Using materials that are not compatible with the process or process conditions could result in the Meter or Controller leaking process fluid outside the pressure boundary of the device, resulting in personnel injury or death.</p> <p>It is recommended that the user check the Meter or Controller on a regular schedule to ensure that it is leak free as both metal and elastomeric seals, gaskets, O-rings and valve seats may change with age, exposure to process fluid, temperature, and /or pressure.</p>	

In a normal use, rollers or flaps located below the black sticker on the indicator screen must be red. If those are blue, it means that the float is either damaged or incorrectly fitted inside the gauge (See below). The float should be checked by removing it from the gauge. (See Figure 4-6) This feature is for rollers/flaps versions only.



Brooks® Magnetic Level Gauge

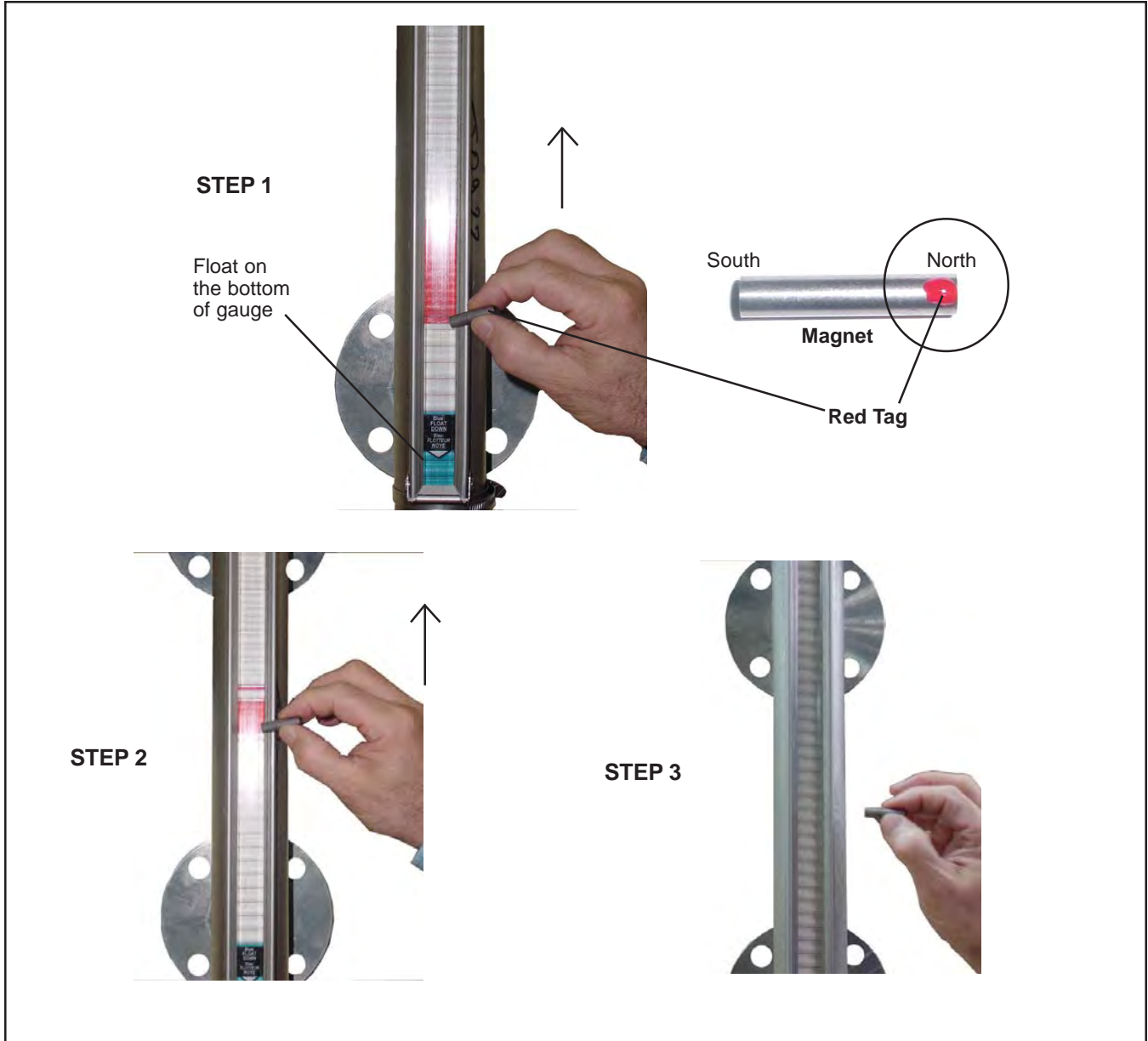

Figure 4-1 Resetting the indicator Flaps or Rollers

STEP 1 The float must be in rest position on the bottom of the gauge. Put the south end of the magnet on the housing bottom and then move it to the top.

STEP 2 Move the magnet until all the red flaps or rollers are white.

STEP 3 When all the flaps or rollers are white, the the instrument is ready to work.

4-2 Glass Tube Replacement

- Remove the lower manufacturer plate.
- Remove the defective tube.
- Slightly loosen the metal clip attaching screws (see Figure 4-2). in order to facilitate the installation of the new tube. Once the tube mounted, tighten all the clips by pinching them against the glass tube.
- For tubes made of several parts, do not forget to install the thermo formable connecting sleeve perpendicular to each junction (see Figure 4-3).
- Make sure that it is fitted with the end plugs and the magnetic follower.
- Slide it up to the extreme position.
- Magnetically couple the follower to the float.
- Re-install the manufacturer plate.

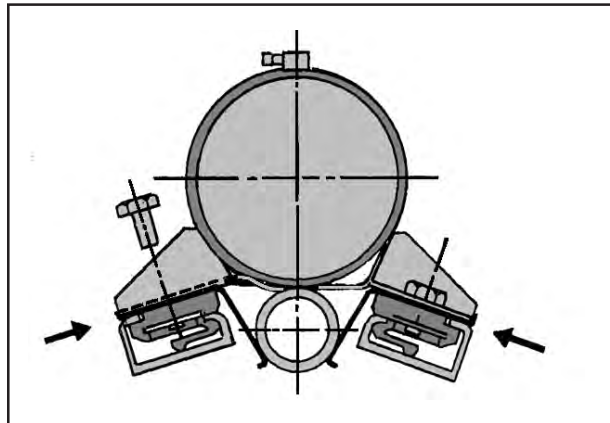

Figure 4-2 Locking Clamps

Note: When locking the clamps, make sure they are set to extreme position.

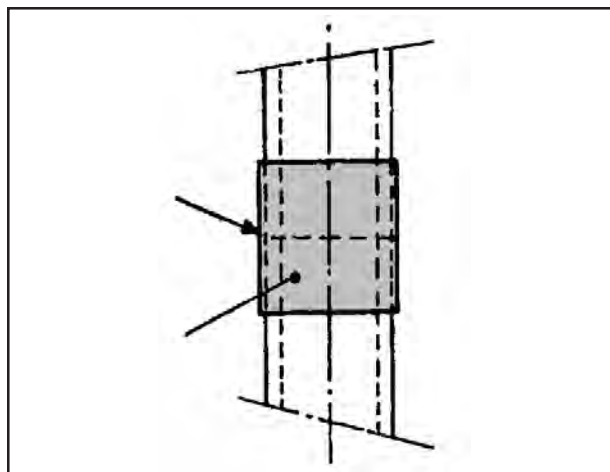

Figure 4-3 Connecting Sleeve

Note: Make sure that both glass tubes are perfectly coaxial to the connecting sleeve (thermoformable 200°C 392°F)

Brooks® Magnetic Level Gauge

4-3 Slider replacement

- Remove the lower manufacturer plate (see Figure 4-4).
- Remove the end plug.
- Replace the defective follower.
- Re-install the plug.
- Magnetically couple the follower to the float.
- Re-install the manufacturer plate.

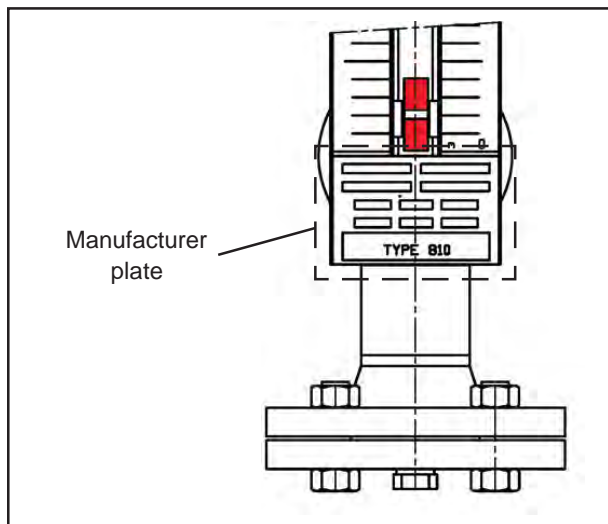

Figure 4-4 Manufacturer Plate Location

4-4 Flaps/Rollers Indicator Replacement

- Release the housing clamps on each sides and middle if any.
- Remove the indicator.
- While re-installing the indicator on the gauge, make sure that the upper side of the damaged float sticker is in line with the connection tube (see Figure 4-5).
- Lock the clamps while making sure that the flap-type strip lies flat on the primary tube, by keeping the flap-type strip firmly flat on the primary tube (see Figure 4-5).

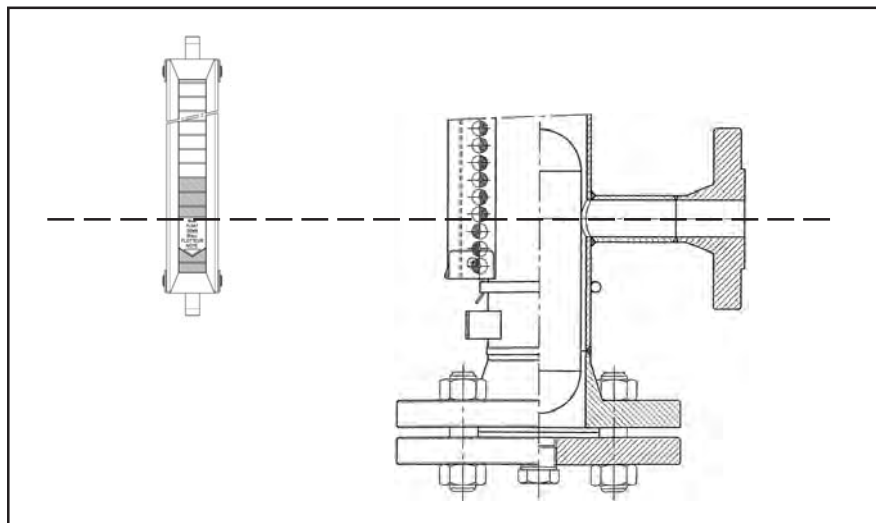

Figure 4-5 Alignment of Indicator to Gauge

4-5 Float Replacement

- Remove the bottom flange.
- Remove the bottom limit stop.
- Replace the float (caution: upper indication (top or haut) on the upper cup of the float).
- Check the seals for proper condition. Replace if necessary (it is recommended to install new seal set).
- Re-install the limit stop and the bottom flange (see Figure 4-6)
- Check for a correct tightness (see Section 2).

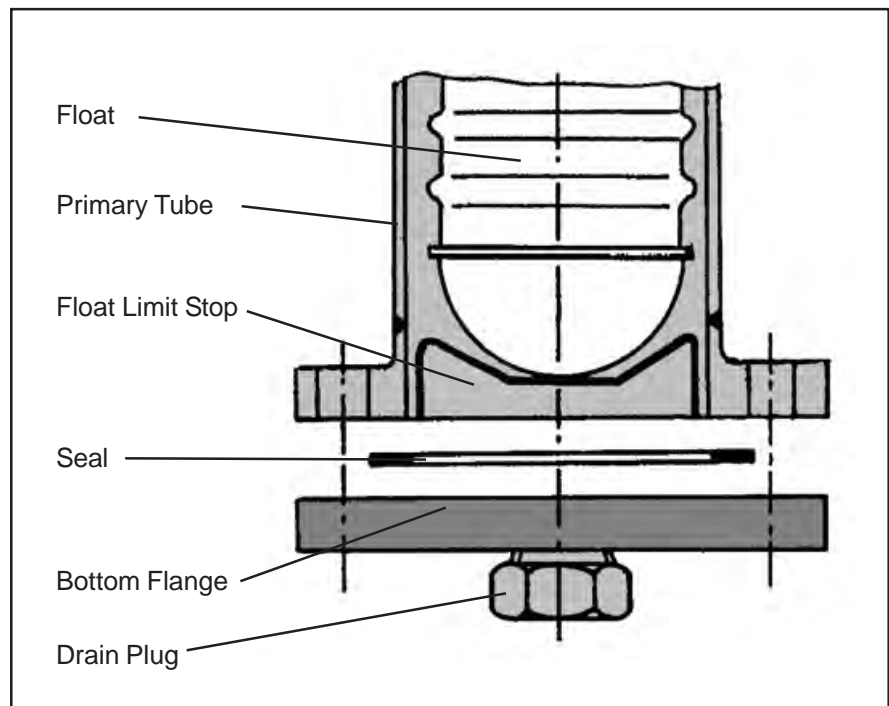

Figure 4-6 Location of Float Limit Stop

Brooks® Magnetic Level Gauge

*THIS PAGE WAS
INTENTIONALLY
LEFT BLANK*

5-1 Spare Parts List

When ordering parts, please specify:

Brooks Serial Number
Model Number
Part Description
Quantity

When ordering any spare parts, it is essential to quote the serial number of the instrument as well as the type of spare part(s) required.

- Index , Ref.: 60190401
- Float, indicator assembly, flaps housing, transmitter, glass tube, etc... according to the serial number given.

Note: Refer to the "**Markings Image**" in the front of this manual for the locations of the instrument's identification and specifications.

- Contacts code S1 : 1 contact in alu. housing IP65 < 200°C
Reference:60190301
- Contacts code S3 : 2 contacts in alu. housing IP65 < 200°C
Reference:60190302
- Contacts code S2 : 1 contact in alu. flameproof housing < 200°C
Reference:60190201
- Contacts code S4 : 2 contacts in alu. flameproof housing < 200°C
Reference:60190202
- Contacts code S6 : 1 contact in alu. housing IP65 HT 200 to 300°C
Reference:60190303
- Contacts code S7 : 2 contacts in alu. housing IP65 HT 200 to 300°C
Reference:60190304
- Contacts code S5 : 1 contact f/w 3m wire Reference:60191401
- Contacts code S8 : 1 contact in alu. Housing ATEX ia
Reference:60190305
- Contacts code S9 : 2 contacts in alu. Housing ATEX ia
Reference:60190306

Brooks® Magnetic Level Gauge

LIMITED WARRANTY

Seller warrants that the Goods manufactured by Seller will be free from defects in materials or workmanship under normal use and service and that the Software will execute the programming instructions provided by Seller until the expiration of the earlier of twelve (12) months from the date of initial installation or eighteen (18) months from the date of shipment by Seller. Products purchased by Seller from a third party for resale to Buyer ("Resale Products") shall carry only the warranty extended by the original manufacturer.

All replacements or repairs necessitated by inadequate preventive maintenance, or by normal wear and usage, or by fault of Buyer, or by unsuitable power sources or by attack or deterioration under unsuitable environmental conditions, or by abuse, accident, alteration, misuse, improper installation, modification, repair, storage or handling, or any other cause not the fault of Seller are not covered by this limited warranty, and shall be at Buyer's expense.

Goods repaired and parts replaced during the warranty period shall be in warranty for the remainder of the original warranty period or ninety (90) days, whichever is longer. This limited warranty is the only warranty made by Seller and can be amended only in a writing signed by an authorized representative of Seller.

BROOKS SERVICE AND SUPPORT

Brooks is committed to assuring all of our customers receive the ideal flow or level solution for their application, along with outstanding service and support to back it up. We operate first class repair facilities located around the world to provide rapid response and support. Each location utilizes primary standard calibration equipment to ensure accuracy and reliability for repairs and recalibration. The primary standard calibration equipment to calibrate our flow products is certified by our local Weights and Measures Authorities and traceable to the relevant International Standards.

Visit www.BrooksInstrument.com to locate the service location nearest to you.

START-UP SERVICE AND IN-SITU CALIBRATION

Brooks Instrument can provide start-up service prior to operation when required.



For some process applications, where ISO-9001 Quality Certification is important, it is mandatory to verify and/or (re)calibrate the products periodically. In many cases this service can be provided under in-situ conditions, and the results will be traceable to the relevant international quality standards.

CUSTOMER SEMINARS AND TRAINING

Brooks Instrument can provide customer seminars and dedicated training to engineers, end users and maintenance persons. Please contact your nearest sales representative for more details.

HELP DESK

In case you need technical assistance:

Americas		1 888 554 FLOW
Europe		+31 (0) 318 549 290
Asia		+81 (0) 3 5633 7100

Due to Brooks Instrument's commitment to continuous improvement of our products, all specifications are subject to change without notice.

TRADEMARKS

Brooks Brooks Instrument, LLC



Brooks Instrument
 407 West Vine Street
 P.O. Box 903
 Hatfield, PA 19440-0903 USA
 T (215) 362 3700
 F (215) 362 3745
 E-Mail BrooksAm@BrooksInstrument.com
www.BrooksInstrument.com

Brooks Instrument
 Neonstraat 3
 6718 WX Ede, Netherlands
 T +31 (0) 318 549 300
 F +31 (0) 318 549 309
 E-Mail BrooksEu@BrooksInstrument.com

Brooks Instrument
 1-4-4 Kitasuna Koto-Ku
 Tokyo, 136-0073 Japan
 T +81 (0) 3 5633 7100
 F +81 (0) 3 5633 7101
 E-Mail BrooksAs@BrooksInstrument.com

Brooks Instrument S.A.S.
 Z.A.de la Tour - ABREST -France
 T +33 (0)4 70 59 81 81
 F +33 (0)4 70 59 96 37
www.BrooksInstrument.com

