

CINEMAX-LIFT

Ceiling projektor lift



1. LIST OF ITEMS:

Lift,
Ceiling closing panel,
Key switch,
Installation template,
Installation manual,
Mounting kit

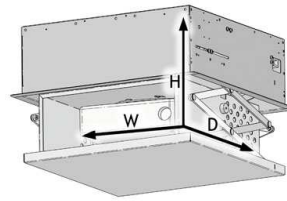

Maximal dimension
of the projector
to CINEMAX-LIFT:
- W - 465 mm
- H - 220 mm
- D - 520 mm

2. INSTALACJA:

- A. Determine the location for lift installation in the ceiling using the template (transport plate A). Drill holes and insert wall plugs (incl. in the mounting kit).

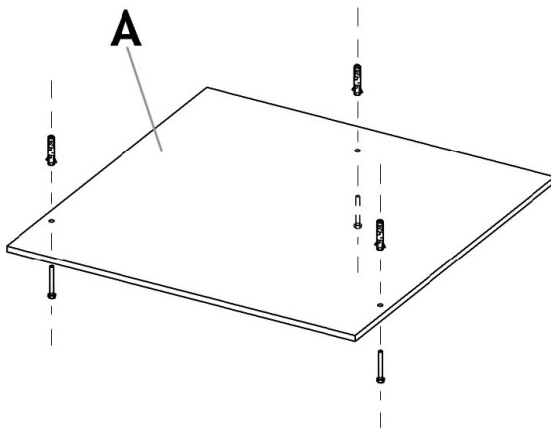

- B. Raise the lift and tighten using screws (marked B) to the standard ceiling.

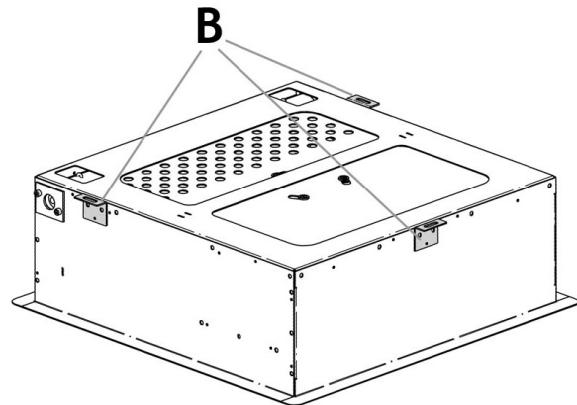

- C. Install universal mount C on the projector using the screws included in the mounting kit.

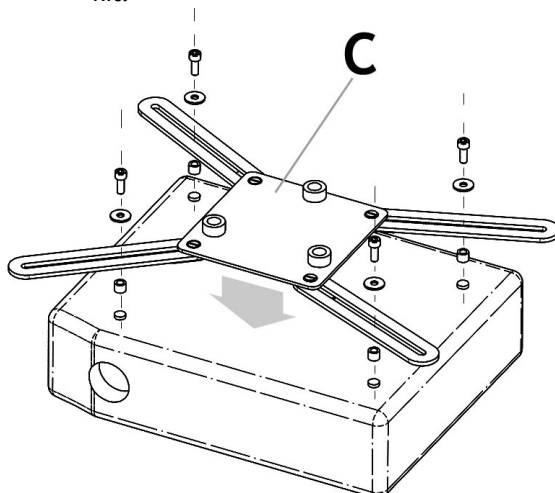

- D. Mount the projector with the mounting element (adapter) in the openings in the lift's base - mechanical platform. Use screws and plastic rings included in the mounting kit.

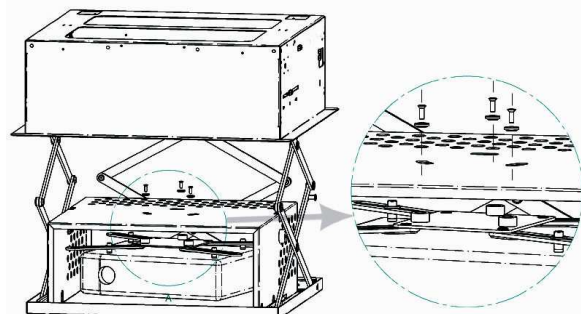

3. SETTINGS AND ADJUSTMENTS:

- A. The D limit switch allows the lift open position to be set. Moving it:
- left - stops the lift earlier (the lift moves out less).
 - right - stops the lift later (the lift moves out more).

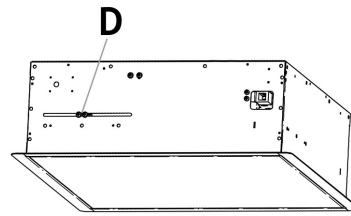

4. TYPES OF INSTALLATION:

- A. Suspended ceiling

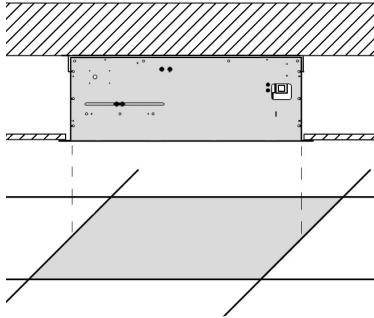

- B. Recess in standard ceiling

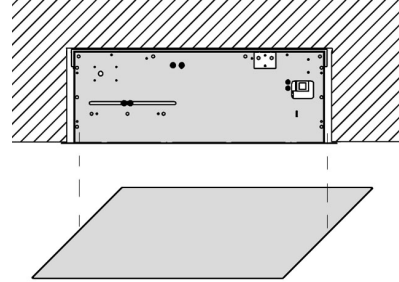

5. SAFETY:

- A. THERMAL - switches the drive off after 4 minutes of continuous lift operation. Should the drive overheat and turn off automatically, allow the lift to rest for approx. 15 minutes.

- B. DRIVE LIMIT SWITCHES. The lift is equipped with drive limit switches setting the maximum upper and lower position of the lift.

Please note! Adjustment of drive switches secured with a seal is prohibited!

- C. SAFETY BRAKE. In the event of a power failure the lift stops immediately. Restoring power enables further operation of the device.

5. ELECTRICAL CONNECTION

- A. The lift should be connected to a 230V power source by appropriately certified personnel. The connection must be made in accordance with the diagram in the manual.

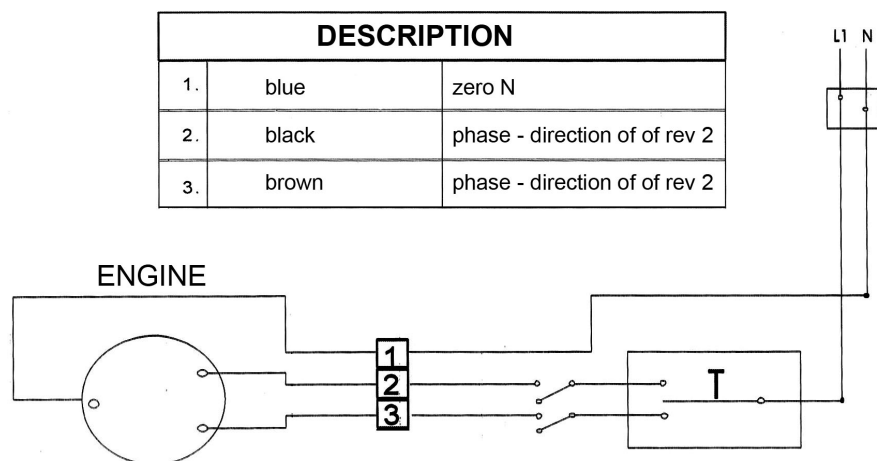

6. DANE TECHNICZNE

Extension:	700 mm
Capacity:	20kg
Reinforcement:	230V / 50 HZ

Manufacturer:
 VIZ-ART Automation
 tel.+48 22/6138899 www.viz-art.eu

Rules of safe operation of VIZ-ART AUTOMATION equipment

SAFETY INFORMATION

CAUTION: To ensure safety of the personnel, make sure to follow the guidelines provided in this instruction manual. Keep the instruction manual for future reference.

- Do not allow children to play with the device controller (switch or remote control).
- Do not leave device controllers within the reach of children.
- Inspect the equipment assembly periodically to identify and repair any damages.
- If any damages are identified, do not use the equipment until the necessary repairs are made.
- Keep appropriate distance from the equipment during operation. In case of a failure, the equipment may constitute a risk of injury or wounds.
- Do not install any items other than those specified in the equipment instruction manual. All installation and mounting works should be done by an engineer with appropriate licenses.
- Inappropriate mounting may damage the product or cause injury.
- Use only elements compliant with the mounting instructions.
- It is prohibited to perform any steps that may damage the power supply cord or plug.
- Do not modify the power cord, i.e. do not make any structural modifications, do not place the cord in immediate vicinity of hot objects, do not bend or twist the cord, do not pull the cord, do not place any heavy objects on the cord, and do not coil the power cord.
- Using the equipment with a damaged power cord may cause electrocution or shorting of the circuits and fire.
- Do not touch the power cord or plug with wet hands.
- Always follow the guidelines provided in this instruction manual and in the equipment mounting instructions.
- Before installing the equipment, make sure it is complete, free of defects, compliant with your order, and has not sustained damage in transport.

INSTALLATION GUIDELINES

- The equipment should be installed by a qualified engineer, in accordance with the guidelines provided in the mounting instructions. Electrical connections should be made by a specialist with an appropriate license.
- Install the equipment using screws and mounting elements appropriate for the conditions of the installation, to which the lift is mounted, and stable, original auxiliary elements, dedicated for the specific lift model.
- After mounting the equipment, before first use, check if it is mounted as per the instructions, and level. If the equipment is not level, adjust the mounting. Do not use equipment that is not properly installed.
- Do not modify or unscrew elements of the equipment, as this may cause a risk of permanent damage to the equipment and/or the safety of the users.

WARRANTY CONDITIONS

The warranty period for the device is 24 months from the date of purchase indicated on the original receipt.

- 1) The warranty period for the device's electric drive is 60 months.
- 2) The warrantor commits to fix free of charge damage suffered by a device delivered to the service point that demonstrates defects resulting from defects in workmanship or materials, which become noticeable during the warranty period.
- 3) The warranty does not cover:
 - a) damage caused by use of the device in a manner other than that described in the user manual,
 - b) damage caused by improper storage or transport,
 - c) mechanical damage,
 - d) abrupt changes in electrical grid voltage,
 - e) disassembly and reassembly,
- 4) Defects will be removed within 14 days from the date the device is accepted on warranty at a service point.
- 5) Service point address

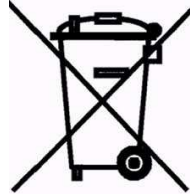

Manufactured after 13.08.2005.

Do not dispose of used electrical and electronic equipment together with municipal waste, due to the presence of substances hazardous to the environment in the equipment. Such devices should be delivered to a collection point for recycling. Information on collection points is available from local government authorities or in stores.



DECLARATION OF CONFORMITY



VIZ-ART AUTOMATION

I hereby declare, with sole responsibility, that the products:

Lifts: SLIM LIFT, SIMPLE Slim, CINE-LIFT, CINEMAX-LIFT, SPAV 30, SPAVMAX, MAX-LIFT, UP-LIFT, WHITEBOARD LIFT, F-LIFT, V-LIFT, SIDE-LIFT, CP-LIFT, CPMAX-LIFT, ADVANCED

to which this declaration relates, in accordance with:

- the Low Voltage Directive 73/23EEC together with the modifications of Directive 93/68/EEC
- EMC Directive 89/336/EEC along with its amendments 92/31/EEC, 93/68/EEC i 91/263/EEC

comply with the following European standards:

EN 60335-2-97 with reference to EN 60335-1
EN 55014-1, EN 55014-2, EN 61000-3-2, EN 61000-3-3

and are CE certified.

