



Mitsubishi Electric Air Conditioner Network System
PI controller
PAC-YG60MCA
Installation/Instruction Manual
Contents

	Page
1. Safety Precautions	1
2. Device Capabilities	1
3. Confirmation of Parts	2
4. Specifications	2
4-1. Product Specifications	2
4-2. External View	2
5. Example of System Configuration	3
6. Installation Method	4
6-1. Parts to be Procured Locally	4
6-2. Installation Procedure	5
7. Wiring Method	6
7-1. Names of Parts	6
7-2. Connecting the Power Line and M-NET Transmission Line	7
7-3. Connecting the Signal Lines	8
(1) Pulse input (non-voltage a contact) ...	8
8. Initial Setting Procedure	9
9. Switch List	10
10. Display Content	11
10-1. Display Content List	11
10-2. Communication Error Status Display	11
11. Test Run	12
12. Precautions for Expansion	12

1 Safety Precautions

- Before using the device, thoroughly read the following safety precautions and use as directed.
- Hazards and levels of danger that can occur due to incorrect handling are classified by the following symbols.

 Warning	Incorrect handling can result in death, serious injury, etc.
 Caution	Incorrect handling can result in injury or damage to the building or its contents.

- After reading this manual, keep this manual for future reference. When the device is reinstalled or repaired, give this manual to those who provide these services. When the user changes, make sure that the new user receives this manual.

WARNING

Ask your dealer or a qualified technician to install the device.
Improper installation by the user may result in electric shock or fire.

Properly install the device on a surface that can withstand the weight of the device.
Device installed on an unstable surface may fall and cause injury.

Only use specified cables. Securely connect each cable so that the terminals do not carry the weight of the cable.
Improperly connected or fixed cables or short-circuited cables may produce heat and/or result in fire.

Do not make any modifications or alternations to the device.
Modifications or improper repair may result in electric shock or fire. Consult your dealer for repair.

Properly install the device according to the instructions in this manual.
Improper installation may result in electric shock or fire.

Have all electrical work performed by an authorized electrician according to the local regulations and instructions in this manual.
Power supply circuit capacity shortage or improper installation may result in electric shock or fire. Ask your dealer or a specialist when performing an electrical work.

Do not move or reinstall the device by yourself.
Improper installation may result in electric shock or fire. Consult your dealer or a specialist when moving or reinstalling the device.

CAUTION

Do not install the device where a flammable gas leak may occur.
If a flammable gas leaks and piles up around the device, it may be ignited and/or explode.

Do not use the device in an unusual environment.
If the device is installed where a large amount of oil (including machine oil), steam or sulfidizing gas is present, this environment may lead the device to a remarkable drop in performance or damage its parts.

When installing the device in a hospital, communication station, or similar place, provide sufficient protection against noise.
An inverter equipment, private power generator, high-frequency medical equipment or radio communication equipment may interfere with the normal operation of this device. On the other hand, the device may affect such equipment by creating noise that disturbs medical treatment or image broadcasting.

Do not put tension on the power supply wires.
If tension is put on the wires, they may break and result in excessive heat and/or fire.

Do not immerse the device in water.
Doing so may lead to electric shock or malfunctions.

Do not install the device where the temperature may become more than 40°C [104°F] or less than 0°C [32°F] or it will be subjected to direct sunlight.
If the device is installed in such place, it may result in deformation or malfunctions.

Do not install the device where a large amount of steam rises, such as in the bathroom or kitchen.
Avoid installing this device where dew condensation occurs. If the device is installed in such places, it may result in electric shock or malfunctions.

Do not install the device where acidic or alkaline solutions or chemical sprays are used frequently.
Doing so may lead to electric shock or malfunctions.

Use standard products with the proper current capacity.
The use of non-standard wires may result in current leak, excessive heat, and/or fire.

Do not touch the main board with hands or tools. Prevent dust from forming on the board.
Doing so may result in fire or malfunctions.

Do not apply an AC power source. The maximum applied voltage for the device is 24 VDC.
Using the incorrect voltage may result in device failure, ignition, and/or fire.

2 Device Capabilities

This device counts pulses from a power meter, gas meter, water meter, and calorimeter.

The combined use of the G(B)-50A and TG-2000A allows for calculating the charges for each unit and performing peak-cut operation (demand control).

Caution: Usage Restrictions

- We take no responsibility for compensation for damages caused by reasons not attributable to us, for opportunities lost as a result of a failure of this device or an electrical power failure on the customer or any third party site, for damages caused by special circumstances, regardless of whether we can predict them or not, for secondary damages, for accidental damages, or for damages to objects other than this device.
We also take no responsibility for compensation for damages caused by the customer's work, including, but not limited to, replacement work, readjustment of machinery and equipment on the local site, and startup and trial operation.
- We take no responsibility because power volume and gas volume, etc. are converted into the pulses to be captured, and performance, accuracy, and the like depend on meters.
- Values measured with this device cannot be used for the transaction and certification purposes mentioned in the Measurement Law.

3 Confirmation of Parts

- Confirm that the box contains the following parts.

Number	Part Name	Quantity
1	PI controller	1
2	Installation/instruction manual (this document)	1

* In addition to the parts mentioned above, other parts need to be procured locally in order to operate this device. Furthermore, other Mitsubishi optional parts may be required depending on how the device is to be used.
For details, refer to "6 Installation Method".

4 Specifications

4-1. Product Specifications

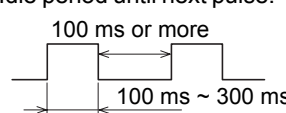
Item	Rating and Specification	
Power Supply	24 VDC±10%: 5 W	
Interface	M-NET communication	17 to 30 VDC (*1)
	Non-voltage a contact input	Number of contacts: 4 Pulse signal: a contact Pulse width: 100 ms to 300 ms (Idle period until next pulse: 100 ms or more)  Rated voltage: 24 VDC Rated current: 1 mA or less (*2)
Environment Conditions	Temperature	Operating temperature range 0 to 40°C [32°F to 104°F] Storage temperature range -20 to 60°C [-4°F to 140°F]
	Humidity	30 to 90%RH (no condensation)
Dimensions	200 (W) × 120 (H) × 45 (D) mm / 77/8 (W) × 43/4 (H) × 125/32 (D) in	
Weight	0.6 kg / 1 3/8 lb	
Current Time Backup during Power Failure	If the power is cut, the internal capacitor will normally keep counting the current time for approximately one week. (The internal capacitor takes approximately a day to charge. Replacement of a battery is not necessary.)	
Installation Environment	Inside a control panel (indoors) * Use this product in a hotel, a business office environment or similar environment.	

*1: Supply electric power from a power unit for the transmission line or an outdoor unit. Furthermore, the power consumption factor of the M-NET circuitry of this device is "1/4" (equivalent to one ME Remote Controller).

*2: Supply electric power from the main unit to the contacts of the meters.

4-2. External View

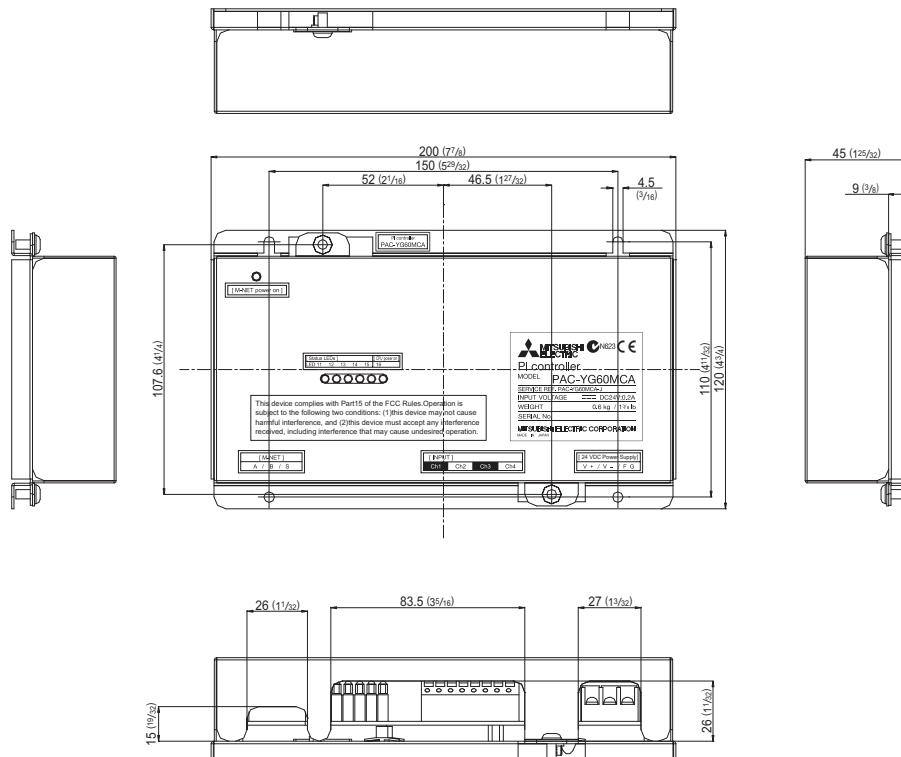

Unit: mm (in)

5 Example of System Configuration

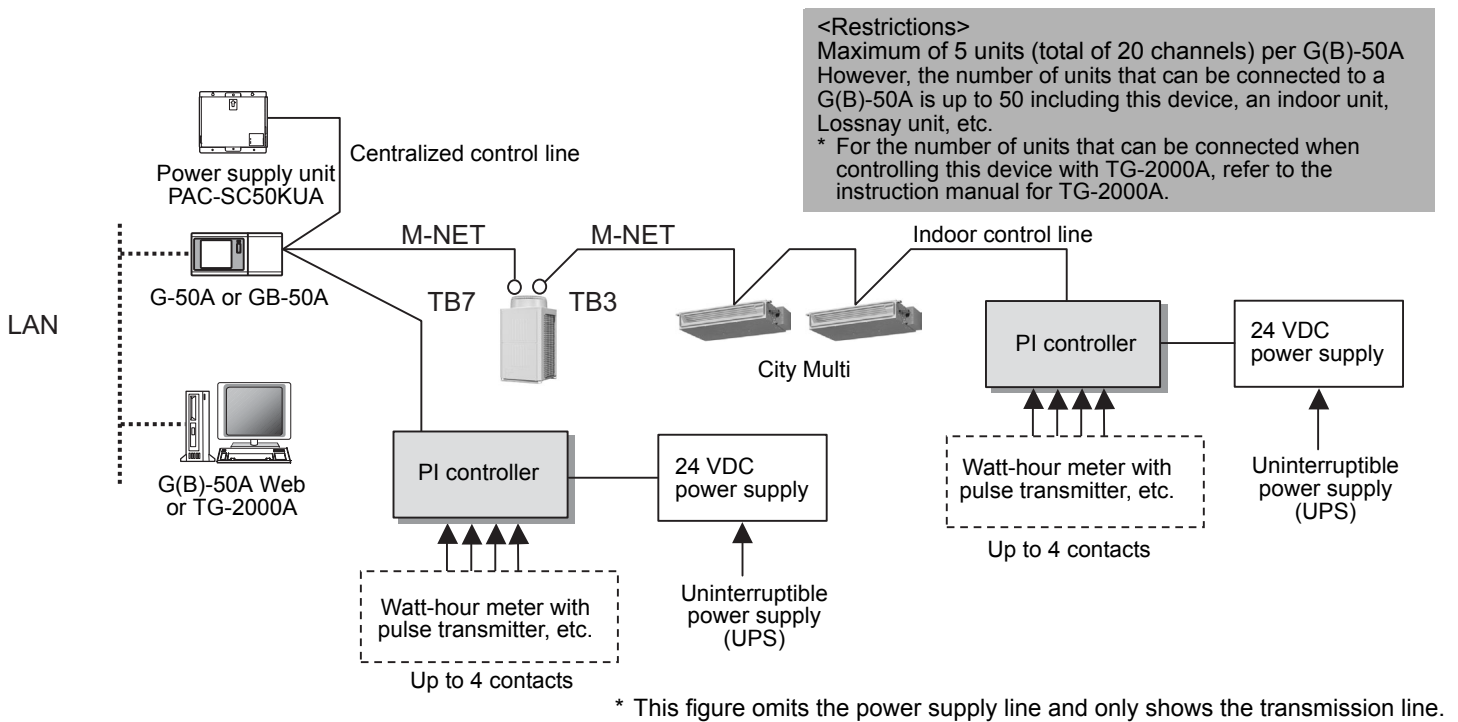

Note:

- For the shield ground of the M-NET centralized control line for central control, use single-point grounding at the power unit for the transmission line.
 However, when supplying electric power to the M-NET centralized control line from the R410A series outdoor unit without using a power supply unit for the transmission line, use single-point grounding at the TB7 of that outdoor unit.
 Furthermore, when connecting this device to the M-NET indoor control line, use grounding at the TB3 for each outdoor unit system.
- Connecting an Uninterruptible power supply (UPS) to the 24 VDC power supply is recommended in order to prevent the loss of pulse data in the event of a power failure.
 If a UPS cannot be connected, try to make the AC power supply to the 24 VDC power supply as much same as the power supply line to the meters.
- This device does not support level meters. To use a level meter, incorporate a Converter circuit externally and convert to pulse input.
- If this device is connected to an M-NET indoor control line and the outdoor unit is down because, for example, the power supply is interrupted for servicing or there is a failure, the PI controller cannot be controlled from the system controller.

6 Installation Method

6-1. Parts to be Procured Locally

Prepare the following parts to install this device.

Required Part	Specification
Unit fixing screws	M4 screw × 4
Power supply for this unit	Power source: 24 VDC 0.2 A (Minimum loading), SELV circuit, power line with grounding terminal Ripple noise: Lower than 200 mVp-p Compatible specification Authorized or CE marked products Subject to regulations: - IEC60950 (or EN60950) - CISPR22/24 (or EN55022/24) - IEC61000-3-2/3-3 (or EN61000-3-2/3-3)
Power line	Use a sheathed vinyl cord or cable. At least 0.75 mm ² (AWG18)
M-NET transmission line	Type of the cable: Sheathed vinyl cords or cable which comply with the following specifications or equivalent. • CPEV Φ 1.2 mm to Φ 1.6 mm • CVVS 1.25 mm ² to 2 mm ² (AWG16 to 14) * CPEV: PE insulated PVC jacketed shielded communication cable * CVVS: PVC insulated PVC jacketed shielded control cable PE: Polyethylene PVC: Polyvinyl chloride Power needs to be supplied to the M-NET circuitry of this device. Use an outdoor unit or a separately purchased power supply unit for the transmission line.
Signal lines	Shows the size of the electric wire (copper wire) that is adapted to the terminal block of this device. Electric wire size (1) Solid wire: Φ 0.65 mm (AWG21) - Φ 1.2 mm (AWG16) (2) Stranded wire: 0.75 mm ² (AWG18) - 1.25 mm ² (AWG16) Single strand: At least Φ 0.18 mm

[Parts to be Purchased Separately]

Name	Model	Application	Remark
Power supply unit	PAC-SC50KUA	Power supply to the M-NET transmission line	This is not required when power is to be supplied from an outdoor unit.

[Recommended Pulse Specifications]

Prepare a measuring instrument that measures the type of pulse signals indicated in table below.

Type	Specifications
Output pulse relay method	Semiconductor relay method
Output pulse width	100 ~ 300 ms (100 ms and above) Choose an instrument that outputs non-voltage a-contact point pulse per each pulse output.
Pulse unit	Watt-hour meter: 0.1 kWh/pulse, 1 kWh/pulse recommended Water meter: m ³ /pulse Gas meter: m ³ /pulse Calorimeter: MJ/pulse * Except for the watt-hour meter, select instruments that take measurements in the appropriate pulse unit.

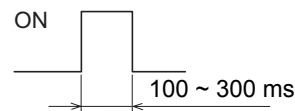

6-2. Installation Procedure

The PI controller PAC-YG60MCA does not have a waterproof structure.

Be sure to install the PI controller inside a control panel that is located indoors.

Prepare a control panel capable of storing this device such as the one shown in the figure. (Install the device in a control panel strong enough to withstand a weight of 0.6 kg [1³/₈ lb].)

This device can be installed flat or vertically. Clear the space shown below when installing.

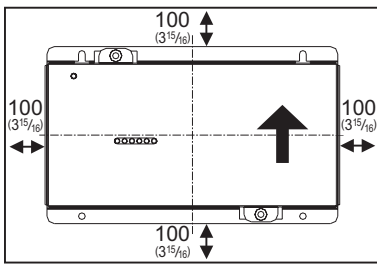

Size of the device: 200 (W) × 120 (H) × 45 (D) mm/
77/8 (W) × 43/4 (H) × 125/32 (D) in

Unit: mm (in)

Note: The space shown above does not include space for peripherals. Additionally, the amount of space necessary varies according to the functions that are used and the wiring method. Secure enough space appropriate for the type of installation.

- (1) Fix the top of this unit to the control panel at two points by loosely tightening the screws (M4) that were procured locally. Fix the bottom in place with two screws and then tighten all four of the screws.

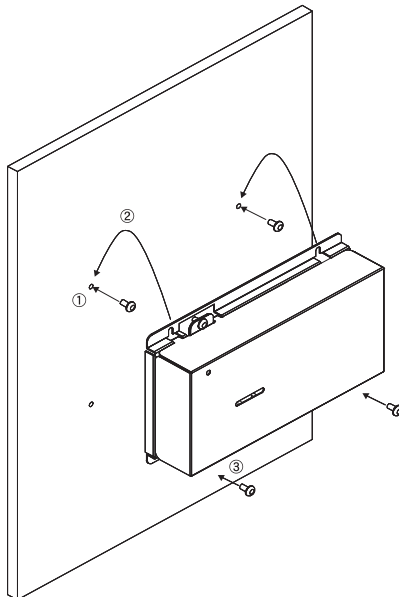

Screw pitch

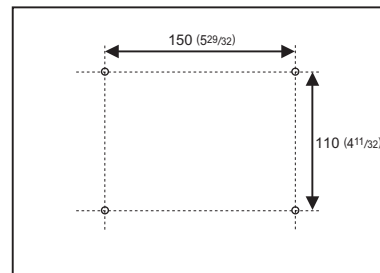

Unit: mm (in)

- (2) To remove the cover, as shown in the figure, remove the two screws for fixing the cover in place and then remove the cover by unhooking the upper hook section from the lower case. To attach the cover, hook the upper hook section on the lower case and then fix the cover in place with the two screws that were removed.

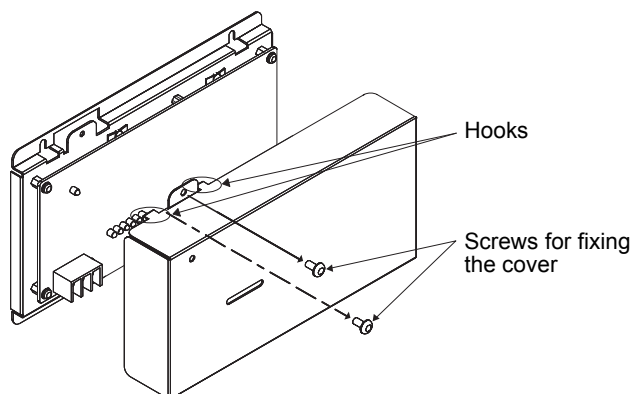

Note: Two hooks are located on the upper section of the cover.

(3) Refer to "7 Wiring Method" and connect the wires for the power line, M-NET transmission line, and input/output signal lines.

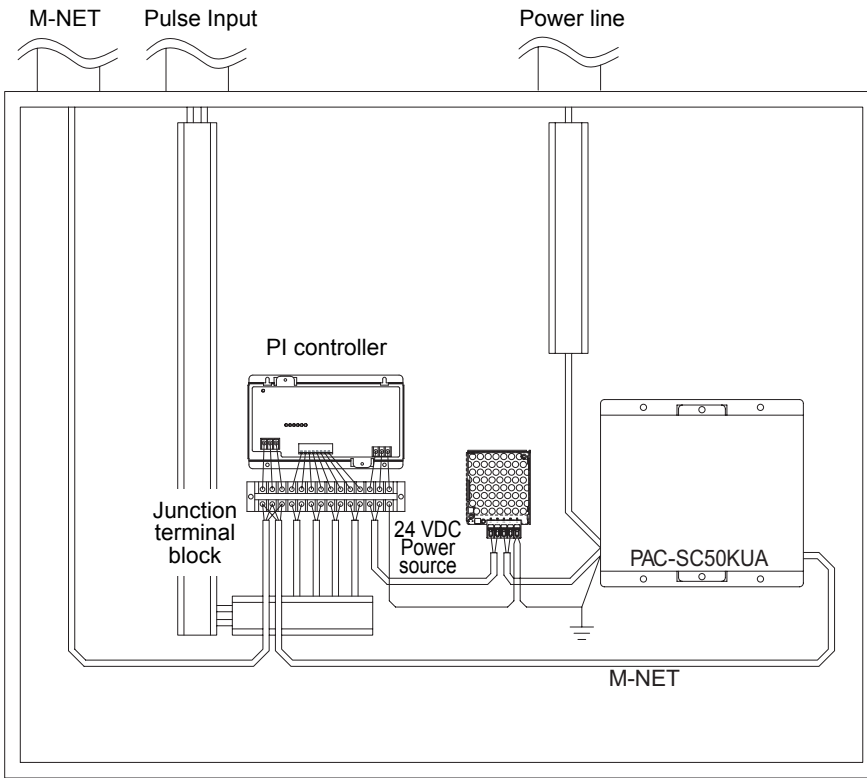

Caution: Perform wiring so that the terminal block is not strained. If strained, use a wire guide or junction terminal to alleviate the stress on the terminal block.

* The wiring in the diagram has been simplified.

Diagram Image (Installed within a Control Panel)

7 Wiring Method

Note: Connecting an Uninterruptible power supply (UPS) to the 24 VDC power supply is recommended in order to prevent the loss of pulse data in the event of a power failure.

7-1. Names of Parts

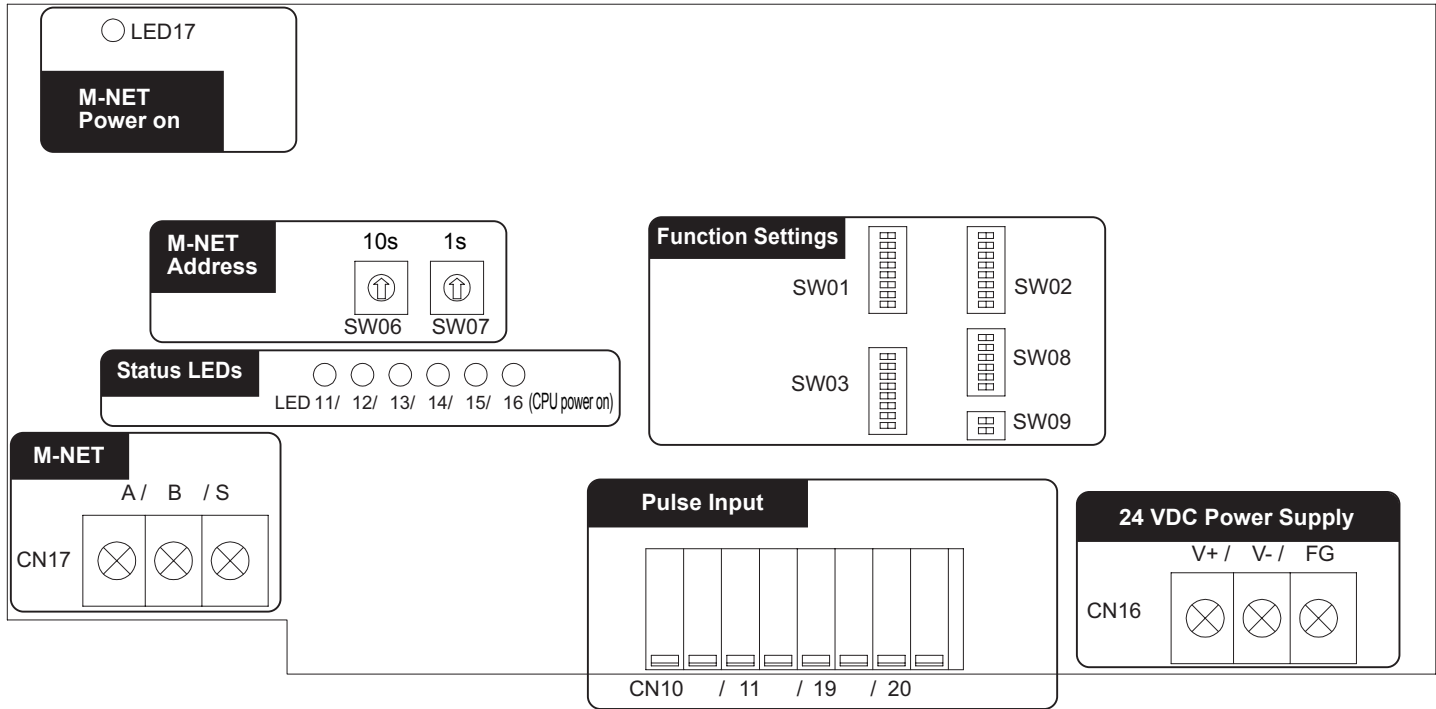

7-2. Connecting the Power Line and M-NET Transmission Line

Tightening torque for terminal screws: 1 N·m

Connect the device to a power supply unit (PAC-SC50KUA) for the transmission line or an outdoor unit (either a centralized control line or indoor control line can be connected).

* Only the M-NET circuitry of this device receives the power from the M-NET transmission line. The power consumption factor is "1/4" (equivalent to one ME Remote Controller).

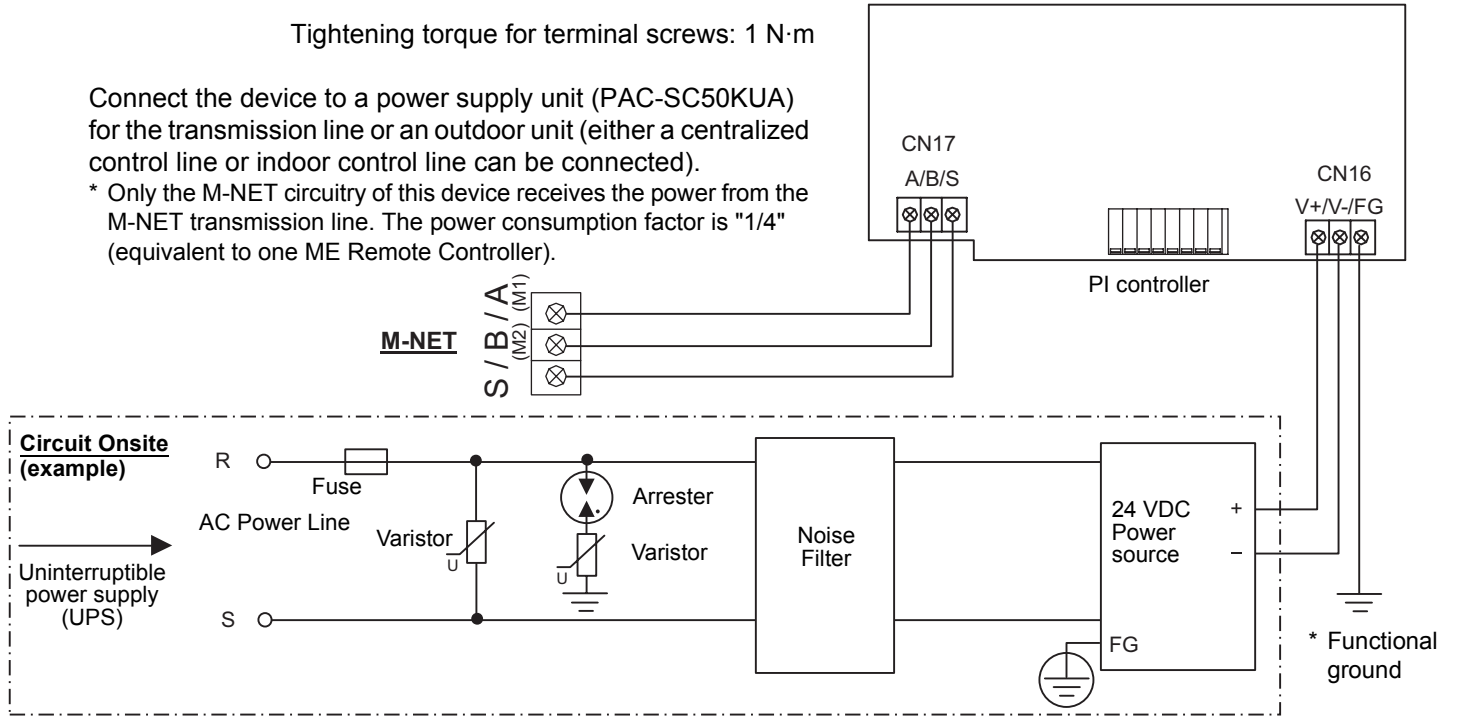

Figure 7-1 Example of Connecting the Power Line and M-NET Transmission Line

⚠ Caution:

- Use a power line and M-NET transmission line that satisfy the specifications described in "6-1 Parts to Procured Locally".
- Attach a circuit comprising the following components to the supply primary side of the 24 VDC power supply.
(1) Varistor, (2) Arrester, (3) Noise filter, (4) Fuse
- It is important to pay attention to the polarity when connecting to the 24 VDC power supply terminal block. Connecting the positive and negative in the reverse order will cause a failure.
- Fix the power line and M-NET transmission line in place on the outside to ensure that the terminal block is not affected by any external force.
Not securely connecting and fixing the wires in place may cause heat generation and fire.
- Make sure that the copper wiring is not short-circuiting the plates (cover, lower case) or neighboring wires.
Cover the shielded line of the M-NET transmission line with materials such as vinyl tape and prevent short-circuiting with the plates.

Note:

- Connecting an Uninterruptible power supply (UPS) is recommended in order to prevent the loss of pulse data in the event of a power failure. If a UPS cannot be connected, try to make the AC power supply to the 24 VDC power supply as much same as the power supply line to the meters.
- If this device is connected to an M-NET indoor control line and the outdoor unit is down because, for example, the power supply is interrupted for servicing or there is a failure, the PI controller cannot be set and monitored from the system controller.

7-3. Connecting the Signal Lines

- Separately procure items such as terminal blocks and cables locally.
- The maximum wire length is 100 m. However, since the use of long wires makes the device susceptible to noise, using wires shorter than 10 m is recommended.

(1) Pulse input (non-voltage a contact)

* To use these, various settings need to be configured. Refer to "8 Initial Setting Procedure".

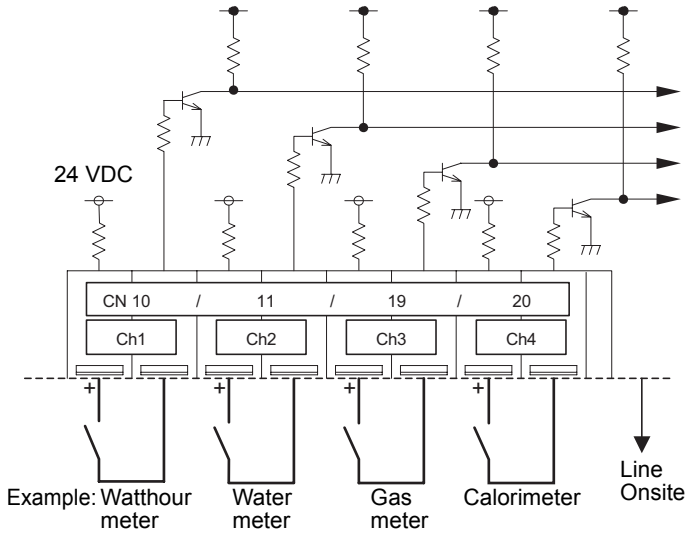

Note:

- The pulse weight can be added to each of the inputs of channels 1 to 4.
For details, refer to "9 Switch List".
- This device does not support level meters.
To use a level meter, incorporate a Converter circuit externally and convert to pulse input.

⚠ Caution:

- The polarity of the input terminals is important, so be sure to match the polarity when using contacts that have polarity.
- Select a contact with a minimum applicable load of 1 mA or less.
- Supply 24 VDC 1 mA from the positive terminal to the contacts of the meters.
- The pulse unit of the watt-hour meter being used should be 1 kWh/pulse or less. Note that the apportioning error will increase if a watt-hour meter with large pulse unit is used.
- Strip 12 ± 1 mm ($15/32 \pm 1/32$ in) of the wire coating and insert firmly into the terminal.
- Make sure that the copper wiring is not short-circuiting the plates (cover, lower case) or neighboring wires.
- Perform wiring so that the terminal block is not strained.
If strained, use a wire guide or junction terminal to alleviate the stress on the terminal block.

8 Initial Setting Procedure

After completing the procedures described in "6 Installation Method" and "7 Wiring Method", set the initial settings in accordance with the procedure described below.

(1) M-NET address settings

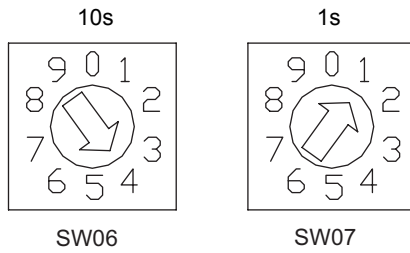

In the case of address "41"

Note:

- An address from 01 to 50 can be set.
- Set an address that is not the same as that of another unit.

The address is set to "01" at factory shipment.

(2) Use the dip switches to select functions.

Select the function required for each input channel to be used.

The switch assignment for each channel is shown below. Configure each of the settings while referring to "9 Switch List".

Setting	Operation Switch			
	Ch1	Ch2	Ch3	Ch4
Whether to use Input contact	SW01-1	SW01-2	SW01-3	SW01-4
Pulse weight value	SW02-1, 2	SW02-3, 4	SW02-5, 6	SW02-7, 8

Note: Be sure to configure the pulse weight settings. If these setting are not configured, the charge function and peak cut control will not work normally because correct measurement of usage amounts will not be made.

(3) Turn on the power of this device.

Verify that the LED16 (CPU power on) and LED17 (M-NET power on) are lit.

(4) Set the time.

Set the current time from a system controller (G(B)-50A or TG-2000A) or a Maintenance Tool.

(5) Set the meter settings so that this device is a target for control from a system controller (G(B)-50A or TG-2000A).

Configure the settings of the system controller (G(B)-50A or TG-2000A). For details, refer to the instruction manual for the G(B)-50A or TG-2000A.

Setting	Setting with G(B)-50A	Setting with TG-2000A
Pulse weight value	Set the pulse weight value setting switch (SW02) to the "SC setting", and set the setting with G(B)-50A or TG-2000A.	
Unit for calculation	Set the volume unit (kWh, m ³ , MJ) with G(B)-50A or TG-2000A.	
Period of time for calculation	–	Set the period of time for calculation of the rates.
Time for calculation	–	Set the time for daily calculation.
Date for calculation	–	Set the date for monthly calculation.

*1: The pulse unit of the watt-hour meter being used should be 1 kWh/pulse or less. Note that the apportioning error will increase if a watt-hour meter with large pulse unit is used.

*2: Values measured with this device cannot be used for the transaction and certification purposes mentioned in the Measurement Law.

Note:

- Configure the settings of the TG-2000A connection system from TG-2000A.
If these setting are not configured, the charge function and peak cut control will not work normally because correct measurement of usage amounts will not be made.
- Be sure to set the pulse weight settings from this device or a system controller (G(B)-50A or TG-2000A).
If these setting are not configured, the charge function and peak cut control will not work normally because correct measurement of usage amounts will not be made.

9 Switch List

SW	Supported Channel	Function	OFF	ON	Remark	
SW01	1	Channel 1	Use of input contact	No	Yes	Set whether to use the Channel 1 input.
	2	Channel 2	Use of input contact	No	Yes	Set whether to use the Channel 2 input.
	3	Channel 3	Use of input contact	No	Yes	Set whether to use the Channel 3 input.
	4	Channel 4	Use of input contact	No	Yes	Set whether to use the Channel 4 input.
	5	Unused				Set to OFF
	6	Unused				Set to OFF
	7	Unused				Set to OFF
	8	Unused				Set to OFF
SW02	1	Channel 1	Pulse weight value setting: SC setting (*1): × 0.1: × 1: × 10:	SW02-1, OFF	SW02-2 OFF	Set 1 pulse of the meter connected to channel 1.
	2			OFF	ON	
	3	Channel 2	Pulse weight value setting: SC setting (*1): × 0.1: × 1: × 10:	SW02-3, OFF	SW02-4 OFF	Set 1 pulse of the meter connected to channel 2.
	4			OFF	ON	
	5	Channel 3	Pulse weight value setting: SC setting (*1): × 0.1: × 1: × 10:	SW02-5, OFF	SW02-6 OFF	Set 1 pulse of the meter connected to channel 3.
	6			OFF	ON	
	7	Channel 4	Pulse weight value setting: SC setting (*1): × 0.1: × 1: × 10:	SW02-7, OFF	SW02-8 OFF	Set 1 pulse of the meter connected to channel 4.
	8			OFF	ON	
SW03	1	Unused			Set to OFF	
	2	Unused			Set to OFF	
	3	Unused			Set to OFF	
	4	Unused			Set to OFF	
	5	Unused			Set to OFF	
	6	Unused			Set to OFF	
	7	Unused			Set to OFF	
	8	Unused			Set to OFF	
SW06	M-NET address		(Address 10s) 0 to 9 (decimal)		An address from 01 to 50 can be set. Set an address that is not the same as that of another unit.	
SW07			(Address 1s) 0 to 9 (decimal)			
SW08	1	Communication error status display (error code display) Temporary mask setting	Change the switch to ON once and then return it to OFF.		Only enabled during communication error status display. * The communication error status display is masked for 10 seconds and the contact input status is displayed.	
	2	Unused			Set to OFF	
	3	Unused			Set to OFF	
	4	Unused			Set to OFF	
	5	Unused			Set to OFF	
	6	Unused			Set to OFF	
SW09	1	Unused			Set to OFF	
	2	Unused			Set to OFF	

Set the dip switches for function selection according to the system to be used.

At the time of shipment, all dip switches are set to OFF and the M-NET address is set to 01.

*1: When using a system controller (G(B)-50A or TG-2000A), select the "SC setting" and set the pulse weight value settings from a system controller. If set to another setting, this dip switch setting is prioritized even when set from a system controller.

*2: The pulse unit of the watt-hour meter being used should be 1 kWh/pulse or less. Note that the apportioning error will increase if a watt-hour meter with large pulse unit is used.

10 Display Content

The LEDs of this device indicate the pulse input status and error status of this device.

10-1. Display Content List

Display Item		Display LED	Content																		
			Note ● : On, ○ : Off, ✨ : Flashing																		
Power supply status	(1) Power supply to CPU	LED16 (CPU power on)	● : Lights when the CPU is energized. ✨ : Flashes during M-NET communication.																		
	(2) Power supply to M-NET circuit	LED17 (M-NET power on)	● : Lights when the M-NET is energized.																		
Input status	Channels 1 to 4	(1) Input status LED12/13/14/15 (Status display LEDs)	<table border="1"> <thead> <tr> <th>Input Method</th> <th>–</th> <th>Ch1</th> <th>Ch2</th> <th>Ch3</th> <th>Ch4</th> </tr> </thead> <tbody> <tr> <td></td> <td>LED11</td> <td>LED12</td> <td>LED13</td> <td>LED14</td> <td>LED15</td> </tr> <tr> <td>Pulse Input</td> <td>○</td> <td colspan="4">● : Input ○ : No Input</td> </tr> </tbody> </table>	Input Method	–	Ch1	Ch2	Ch3	Ch4		LED11	LED12	LED13	LED14	LED15	Pulse Input	○	● : Input ○ : No Input			
Input Method	–	Ch1	Ch2	Ch3	Ch4																
	LED11	LED12	LED13	LED14	LED15																
Pulse Input	○	● : Input ○ : No Input																			
Communication error status (*1)	(1) 4-digit error code	LED12/13/14/15 (Status display LEDs)	Refer to "Communication Error Status Display".																		

*1: If a communication error occurs, switch to "Communication Error Status Display". Changing SW08-1 from ON to OFF masks the "Communication Error Status Display" for 10 seconds so that the input status of channels 1 to 4 can be displayed.

10-2. Communication Error Status Display

If a communication error occurs, a 4-digit error code will be repeatedly displayed according to the steps shown below.

Communication error status display consists of the following 10 steps. This operation is performed repeatedly to indicate the 4-digit error code for the communication error.

Furthermore, changing SW08-1 from ON to OFF masks the "Communication Error Status Display" for 10 seconds so that the input status of channels 1 to 4 can be displayed.

Note ● : On, ○ : Off, ✨ : Flashing

	LED11	LED12	LED13	LED14	LED15	Function	Remark
	Error cord display (Binary number indication)						
	Common	2 ³ =8	2 ² =4	2 ¹ =2	2 ⁰ =1		
STEP1	○	✨	✨	✨	✨	"Error Status Display" Starting Point Indication	LEDs 12 to 15 flash 3 times
STEP2	○	○	○	○	○	Blank	Turn Off
STEP3	●	●/○	●/○	●/○	●/○	Error code 1000's digit	Error code 1000's digit indication In the case of 6, ○●●○
STEP4	○	○	○	○	○	Blank	Turn Off
STEP5	●	●/○	●/○	●/○	●/○	Error code 100's digit	Error code 100's digit indication In the case of 6, ○●●○
STEP6	○	○	○	○	○	Blank	Turn Off
STEP7	●	●/○	●/○	●/○	●/○	Error code 10's digit	Error code 10's digit indication In the case of 0, ○○○○
STEP8	○	○	○	○	○	Blank	Turn Off
STEP9	●	●/○	●/○	●/○	●/○	Error code 1's digit	Error code 1's digit indication In the case of 7, ○●●●
STEP10	○	○	○	○	○	Blank	Turn Off

The error codes that are displayed for M-NET communication errors are as shown below.

Error Code	Description of Error
6600	Multiple address error
6601	M-NET polarity unset error
6602	Transmission processor hardware error
6603	Transmission circuit bus-busy error
6606	Communications with transmission processor error
6607	No ACK error
6608	No return of response frame

11 Test Run

Use the following procedure to confirm operation of the system.

- (1) Configure the settings of this device and the system controllers while referring to "8 Initial Setting Procedure".
- (2) Perform an operation from a system controller and confirm whether a connected device can be operated normally.
 - (1) Confirm that there is no incorrect wiring of the signal lines from the meters.
 - (2) Input a pulse from a connected meter to the PI controller.
 - (3) Confirm whether the value increased by the pulse input and the data value on the system controller side match.
 - (4) Set the data of the system controller to the current value of the meter and confirm whether the system controller and meter values match.

If there is a problem, check the wiring and settings.

For details on configuring settings, refer to "8 Initial Setting Procedure" and "9 Switch List".

Note:

- Various settings related to the charge operation need to be configured from the TG-2000A prior to starting the charge function operation. Furthermore, in such a case, be sure to perform a charge test run according to the instruction manual for TG-2000A.
- Do not turn the power OFF after starting operation. The power rate will not be counted while the power interruption.

12 Precautions for Expansion

Observe the following matters when expanding the watt-hour meter or meters.

- (1) The power must be turned OFF while expanding the units. The power rate will not be counted while the power is OFF.
- (2) After expanding the units in the charge system, change the system settings with TG-2000A, check the settings, and test the operation.

This product is designed and intended for use in the residential, commercial and light-industrial environment.

This product at hand is based on the following EU regulations:

- Low Voltage Directive 73/23/EEC
- Electromagnetic Compatibility Directive 2004/108/EC

NOTE:

This equipment has been tested and found to comply with the limits for a Class B digital device, pursuant to Part 15 of the FCC Rules. These limits are designed to provide reasonable protection against harmful interference in a residential installation. This equipment generates, uses and can radiate radio frequency energy and, if not installed and used in accordance with the instructions, may cause harmful interference to radio communications.

However, there is no guarantee that interference will not occur in a particular installation.

If this equipment does cause harmful interference to radio or television reception, which can be determined by turning the equipment off and on, the user is encouraged to try to correct the interference by one or more of the following measures:

- Reorient or relocate the receiving antenna.
- Increase the separation between the equipment and receiver.
- Connect the equipment into an outlet on a circuit different from that to which the receiver is connected.
- Consult the dealer or an experienced radio/TV technician for help.