

# NordicTrack®

## CABLE CROSS

Model No. 831.6002.1

Serial No. \_\_\_\_\_

Write the serial number in the space above for future reference.

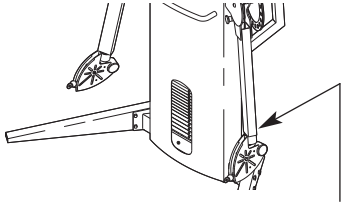

Serial Number Decal

## USER'S MANUAL

### QUESTIONS?

As a manufacturer, we are committed to providing complete customer satisfaction. If you have questions, or if a part is damaged or missing, PLEASE CONTACT OUR CUSTOMER SERVICE DEPARTMENT DIRECTLY.

CALL TOLL-FREE:

**1-888-825-2588**

Mon.–Fri., 6 a.m.–6 p.m. MST

ON THE WEB:

[www.nordictrackservice.com](http://www.nordictrackservice.com)

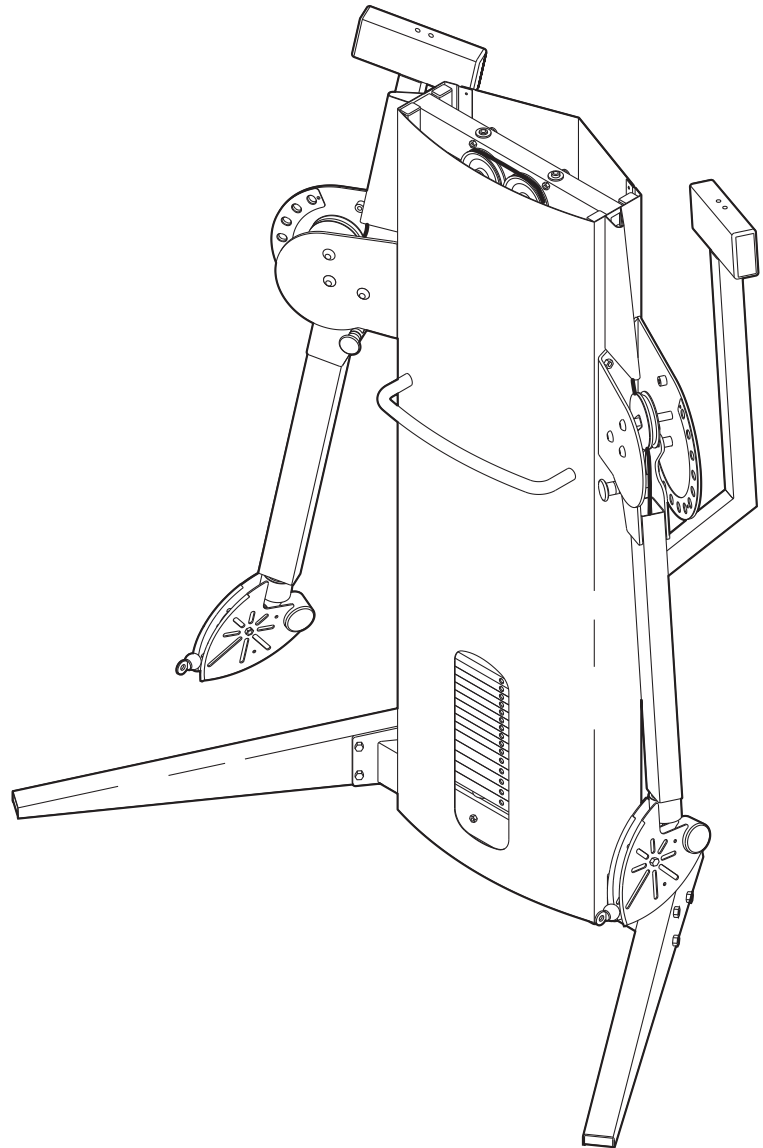

### CAUTION

Read all precautions and instructions in this manual before using this equipment. Save this manual for future reference.



Visit our website at

[www.nordictrack.com](http://www.nordictrack.com)

*new products, prizes,  
fitness tips, and much more!*

# TABLE OF CONTENTS

WARNING DECAL PLACEMENT .....	2
IMPORTANT PRECAUTIONS .....	3
BEFORE YOU BEGIN .....	4
ASSEMBLY .....	5
ADJUSTMENTS .....	7
CABLE DIAGRAM .....	9
PART LIST .....	10
EXPLODED DRAWING .....	11
ORDERING REPLACEMENT PARTS .....	Back Cover
LIMITED WARRANTY .....	Back Cover

## WARNING DECAL PLACEMENT

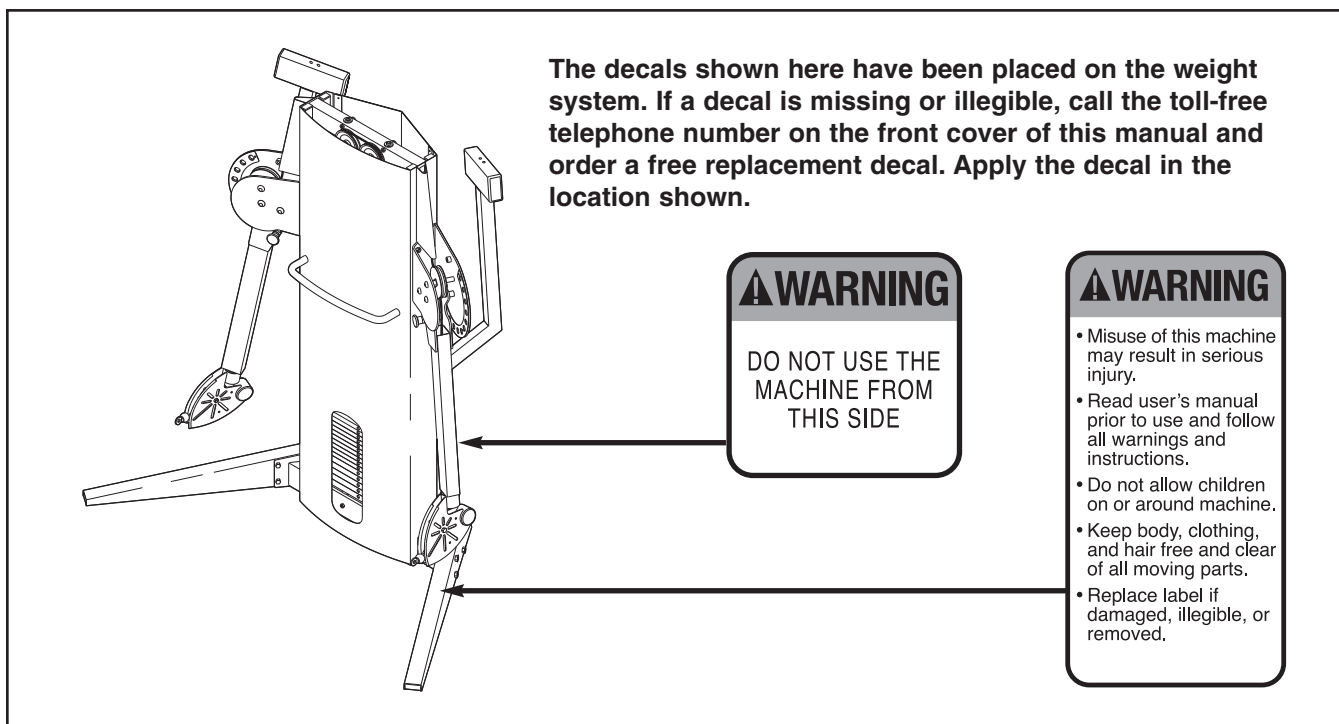

# IMPORTANT PRECAUTIONS

**⚠ WARNING:** To reduce the risk of serious injury, read the following important precautions before using the weight system.

1. Read all instructions in this manual and all warnings on the weight system before using the weight system. Use the weight system only as described in this manual.
2. It is the responsibility of the owner to ensure that all users of the weight system are adequately informed of all precautions.
3. The weight system is intended for home use only. Do not use the weight system in any commercial, rental, or institutional setting.
4. Keep the weight system indoors, away from moisture and dust. Place the weight system on a level surface, with a mat beneath it to protect the floor or carpet. Make sure that there is enough clearance around the weight system to mount, dismount, and use the weight system.
5. Inspect and properly tighten all parts regularly. Replace any worn parts immediately.
6. Keep hands and feet away from moving parts.
7. Keep children under 12 and pets away from the weight system at all times.
8. Always wear athletic shoes for foot protection while exercising.
9. Make sure that the cable remains on the pulleys at all times. If the cable binds as you are exercising, stop immediately and make sure that the cable is on the pulleys. Replace all cables at least every two years.
10. The weight system is designed to be used only with the included weight. Do not use the weight system with dumbbells or any other type of weight to increase the resistance.
11. Always make sure that the weight pin is inserted fully into the weight stack before exercising.
12. If you feel pain or dizziness at any time while exercising, stop immediately and begin cooling down.

**⚠ WARNING:** Before beginning this or any exercise program, consult your physician. This is especially important for persons over the age of 35 or persons with pre-existing health problems. Read all instructions before using. ICON assumes no responsibility for personal injury or property damage sustained by or through the use of this product.

# BEFORE YOU BEGIN

Thank you for selecting the versatile NordicTrack™ CABLE CROSS weight system. The weight system offers a selection of weight stations designed to develop every major muscle group of the body. Whether your goal is to tone your body, build dramatic muscle size and strength, or improve your cardiovascular system, the weight system will help you to achieve the specific results you want.

**For your benefit, read this manual carefully before using the weight system.** If you have questions after

reading this manual, please see the front cover of this manual. To help us assist you, note the product model number and serial number before contacting us. The model number is 831.6002.1. The serial number can be found on a decal attached to the weight system (see the front cover of this manual).

Before reading further, please review the drawing below and familiarize yourself with the parts that are labeled.

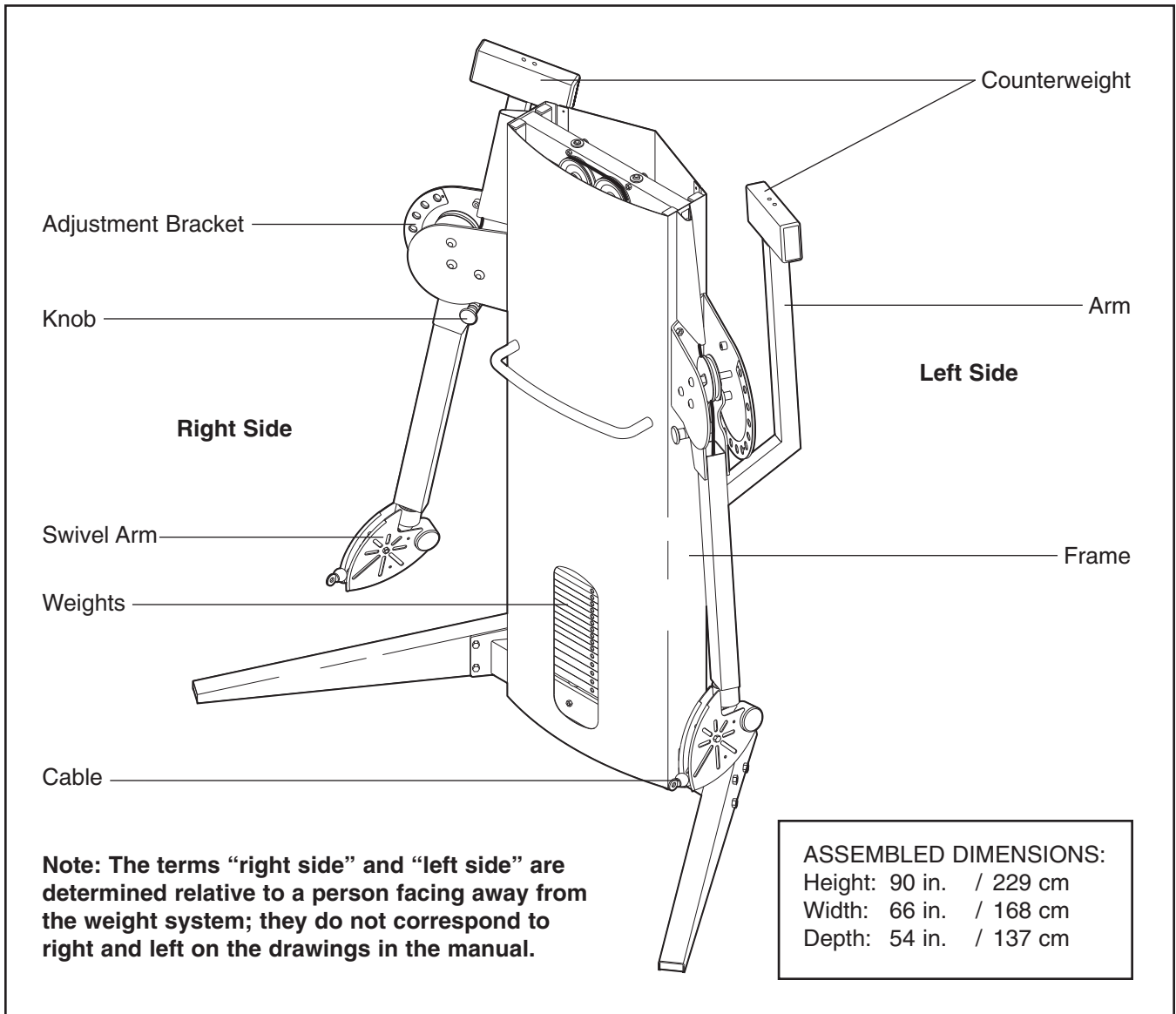

# ASSEMBLY

## Make Things Easier for Yourself



Everything in this manual is designed to ensure that the weight system can be assembled successfully by anyone. Most people find that by setting aside plenty of time, assembly will go smoothly.

**Before beginning assembly, carefully read the following information and instructions:**

- Assembly requires two persons.
- Place all parts in a cleared area and remove the packing materials. Do not dispose of the packing materials until assembly is completed.
- Tighten all parts as you assemble them, unless instructed to do otherwise.

- As you assemble the weight system, make sure all parts are oriented as shown in the drawings.

**Allen wrenches and the following tools (not included) are required for assembly:**

- **Two adjustable wrenches** 
- **One standard screwdriver** 
- **One Phillips screwdriver** 
- **Lubricant (three grease packs are included).**

Assembly will be more convenient if you have a socket set, a set of open-end or closed-end wrenches, or a set of ratchet wrenches.

1.

**Before beginning assembly, make sure you understand the information in the box above. Important: Some of the parts described in the assembly steps may be pre-assembled.**

Remove the four packing bolts and locknuts (not shown) from the indicated locations at the base of the Frame (1) and the pallet (not shown). Discard the packing bolts, locknuts, and pallet.

Attach a Stabilizer (3) to the base of the Frame (1) with four M10 x 84mm Button Head Screws (58), four M10 Washers (55), and four M10 Nylon Locknuts (63) as shown.

**Attach the other Stabilizer (3) to the other side of the Frame (1) in the same manner.**

**If the floor beneath the weight system is not even, level the weight system by placing foot Spacers (83) between the appropriate Rubber Feet (50) and the Stabilizer (3) (see the inset drawing).**

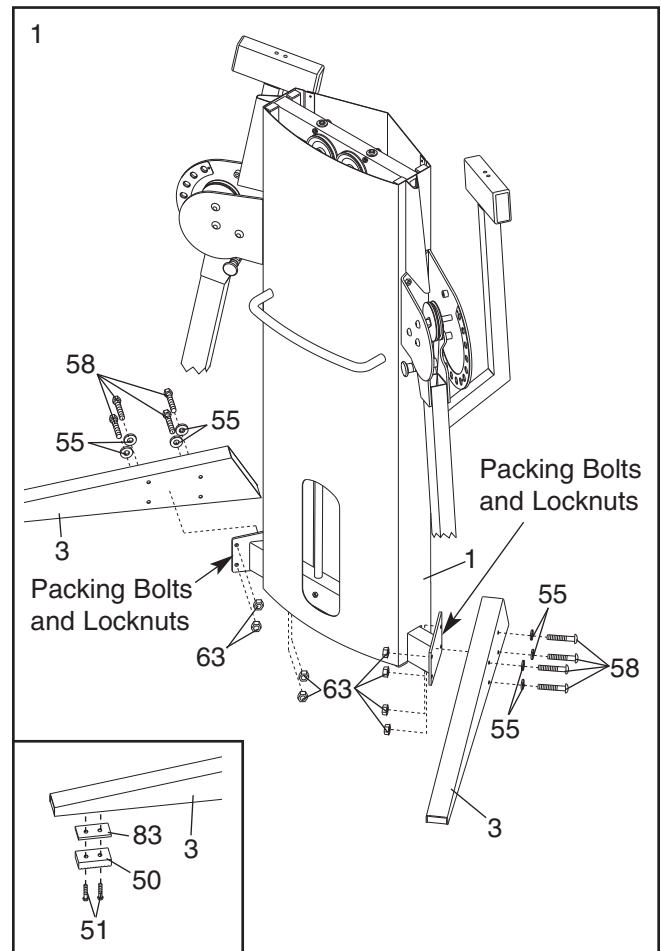

- Remove the Shroud (not shown) from the back of the weight system. (**Note: The cover on the Frame [1] is shown removed for clarity; the cover cannot be removed.**) Remove the four indicated M6 x 64mm Bolts (59) from the Frame. Remove the Weight Guides (16).

Lubricate the inside of the welded tubes on the Top Weight (15) with grease.

**See the inset drawing.** Position the Arms (19, 20) as shown (see ADJUSTING THE ARMS on page 7). Attach the two ends of the Cable (33) together with two Cable Clips (10).

Orient the two Weight Bumpers (4) so the wide ends are over the indicated holes in the bottom of the Frame (1). Insert the two included dowels (not shown) into the Weight Bumpers and the Frame. Slide the five 20-pound Weights (13) and the nine 10-pound Weights (14) onto the dowels. **Note: Make sure that the Weights are stacked in order so that the 10-pound Weight marked “1 5” is on top, and the 20-pound Weight marked “15 100” is on the bottom.**

Remove a dowel (not shown) from the stack of Weights (13, 14). Reinsert a Weight Guide (16) into the Frame (1) and the hole in the Weights. **Repeat with the other Weight Guide.** Secure the Weight Guides to the Frame with the four M6 x 64mm Bolts (59), the four M6 Washers (81), the four Weight Guide Spacers (5), and the four M6 Nylon Locknuts (60).

Disconnect the ends of the Cable (33) and lower the Top Weight (15), so that the weight selector is inserted into the middle hole in the stack of Weights (13, 14).

**Make sure the Cable Traps (78) are oriented as shown in the CABLE DIAGRAM on page 9.** Replace the Shroud (not shown).

- Attach a Handle (9) to a Cable Eye (37) with a Cable Clip (10). Attach the other Handle to the other Cable Eye in the same manner.
- Make sure that all parts have been properly tightened. The use of the remaining parts will be explained in ADJUSTMENTS beginning on the following page.**

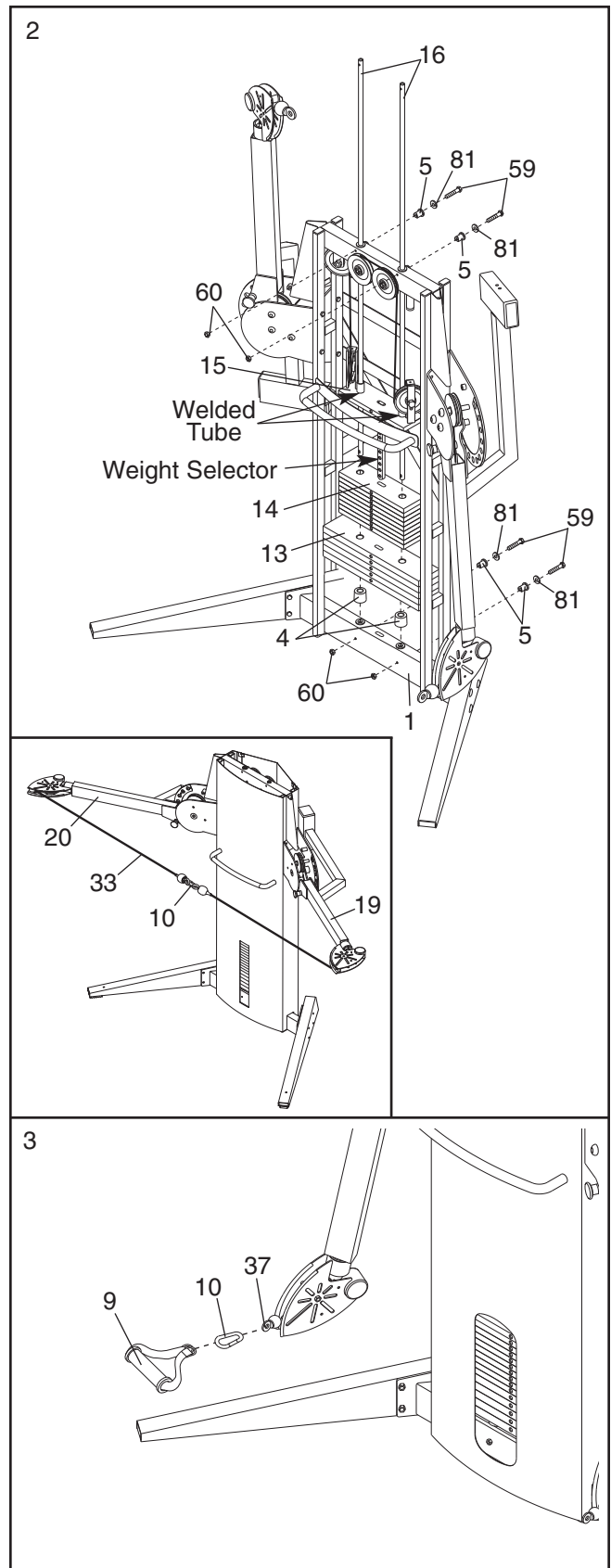

# ADJUSTMENTS

This section explains how to adjust the weight system. Refer to the accompanying exercise guide to see the correct form for each exercise.

Make sure that all parts are properly tightened each time the weight system is used. Replace any worn parts immediately. The weight system can be cleaned with a damp cloth and a mild, non-abrasive detergent. Do not use solvents.

## CHANGING THE WEIGHT SETTING

To change the weight setting of the weight stack, insert the Weight Pin (12) under the desired Weight (13, 14). Make sure to insert the Weight Pin until the bent end of the Weight Pin is touching the Weights, and turn the bent end upward. **Note: The weight system works best when at least two Weights are used.**

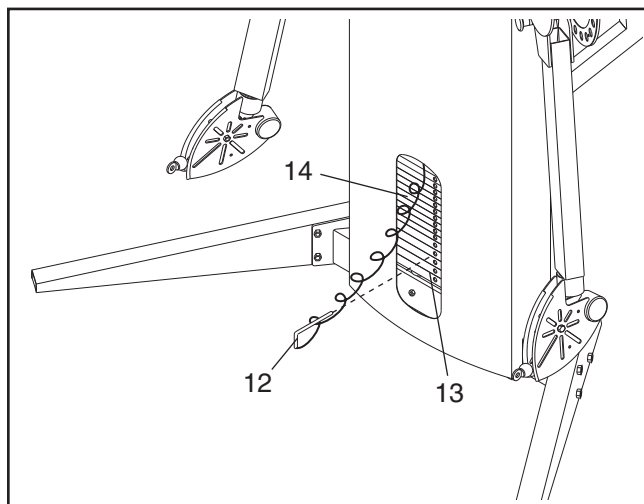

## ADJUSTING THE ARMS

The Arms (19, 20) can be adjusted to any of eleven positions for different exercises. To position an Arm, first pull the Knob (32) out as far as it will go. Move the Arm to the desired position, and then engage the Knob into a hole in the Adjustment Bracket (23, 24).

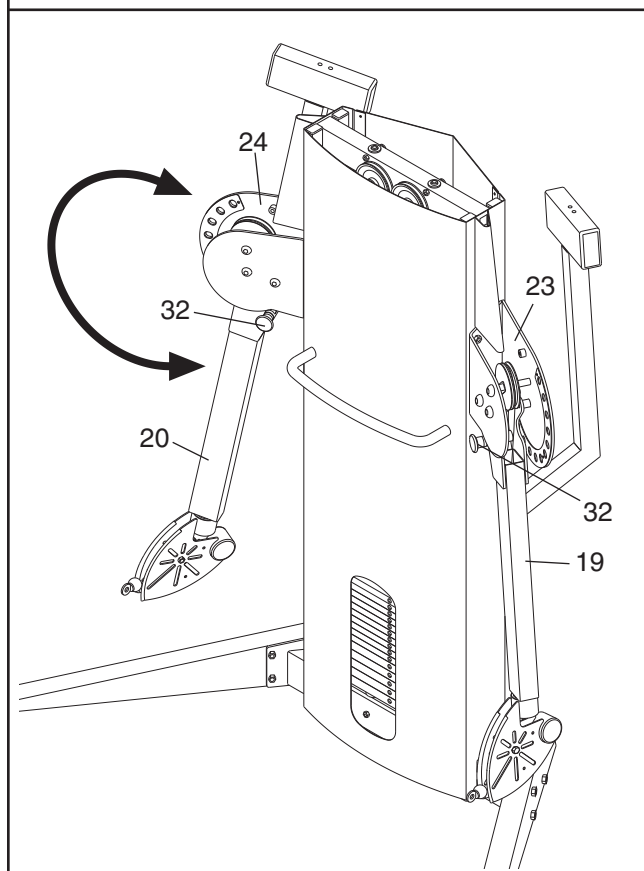

## TIGHTENING THE CABLE

Woven cable, the type of cable used on the weight system, can stretch slightly when it is first used. If there is slack in the Cable (33) **when the arms are in the straight up position** before resistance is felt, the Cable should be tightened. Note: There will be slack in the Cable when the arms are in any other position.

Slack can be removed from the Cable (33) by moving either or both of the indicated 115mm Pulleys (34) in the brackets on the Top Weight (15). First, remove the Shroud (not shown). Then, loosen an M10 x 60mm Bolt (77) and an M10 Nylon Locknut (63), and move the Pulley down. Finally, **make sure the Cable Traps (78) are oriented as shown in the CABLE DIAGRAM on page 9**, and retighten the Bolt and the Nylon Locknut. Then, replace the Shroud.

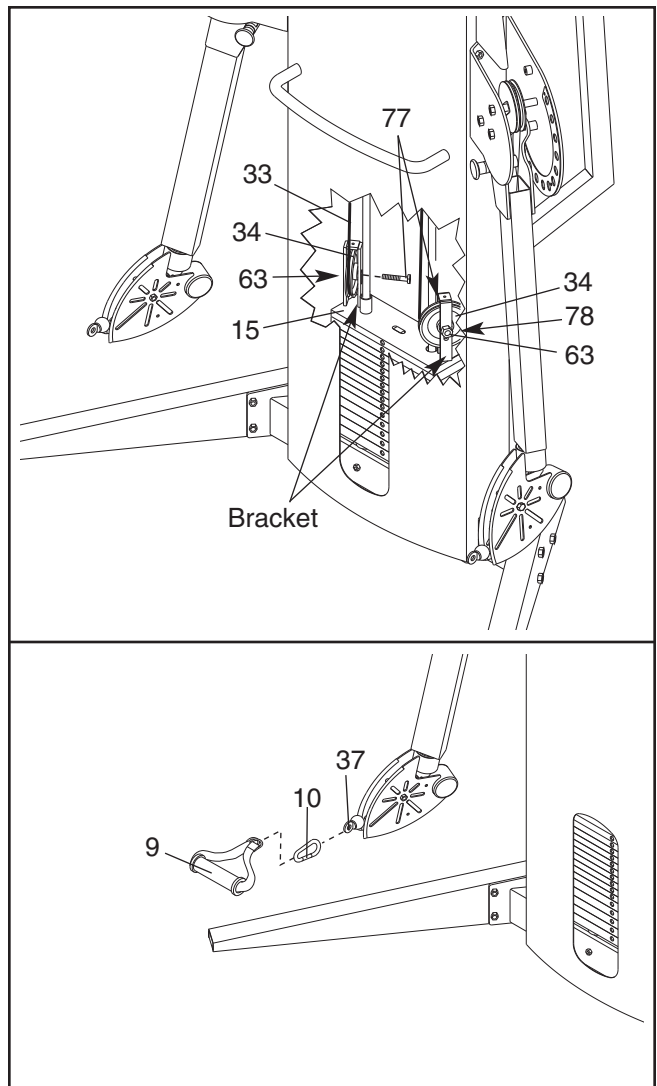

## CHANGING ACCESSORIES

A Handle (9) or the Ankle Strap (not shown) can be attached to a Cable Eye (37) with a Cable Clip (10). Attach the other Handle to the other Cable Eye in the same manner.

## REINSTALLING THE CABLE

**If the cable tends to slip off the pulleys, the cable may have become twisted. Remove the cable and re-install it.**

1. Create slack in the cable by removing the weight pin and pulling one of the handles out six to eight inches. Insert the weight pin into the third weight plate and the tube on the bottom of the top weight.
2. Push the black rubber cover off the aluminum coupler and slide the cover up the cable to contact the swivel arm.
3. Loosen the four M5 x 8mm screws in the coupler and pull the cable free.
4. Remove the cable from the weight system.
5. Reinstall the cable. (See the CABLE DIAGRAM on page 9 for proper cable routing.)
6. Reinsert the cable and the sheath into the coupler so that all of the bare cable is in the hole.
7. Retighten the four screws into the threaded holes. Tighten the screws equally until they contact the cable. Then, tighten each screw alternately 1/4 turn, until all are set to 85 inch-pounds (9.6 Newton-meters).
8. Slide the rubber coupler cover over the coupler, remove the weight pin, and lower the handle.

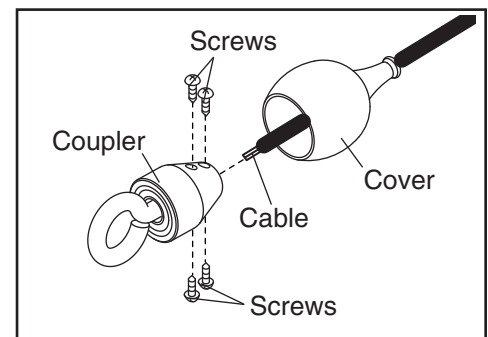

**Note: If the cable needs to be replaced, see ORDERING REPLACEMENT PARTS on the back cover of this manual.**



# CABLE DIAGRAM

The cable diagram shows the proper routing of the cable. Use the diagram to make sure that the cable and the cable traps have been assembled correctly. If the cable has not been correctly routed, the weight system will not function properly and damage may occur. The numbers show the correct route for the cable. **Make sure that the cable traps do not touch or bind the cable. Note: The indicated cable traps on pulleys 4 and 7 should be in a five o'clock position, as shown.**

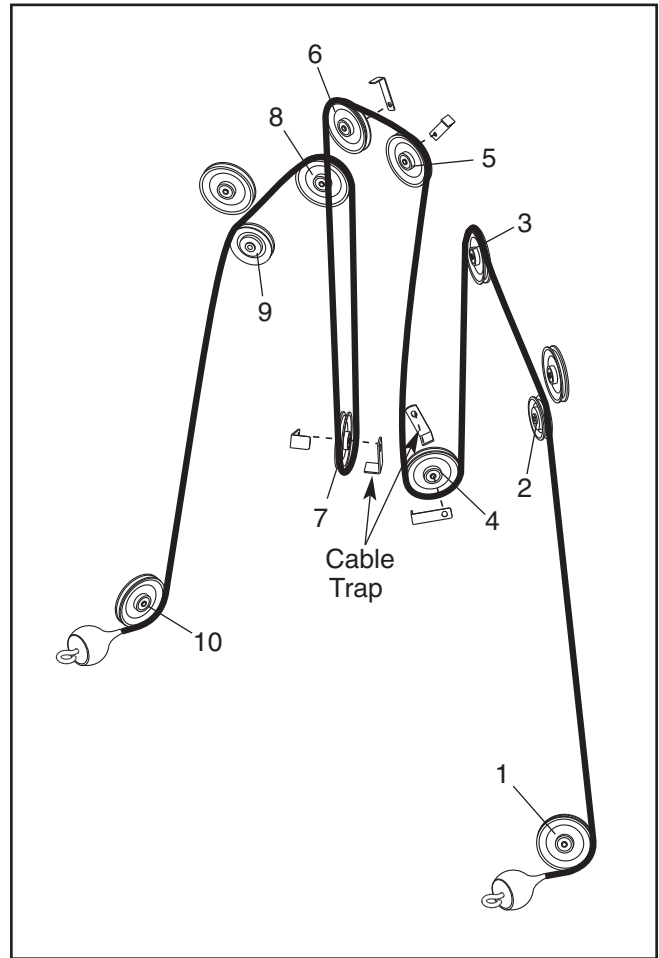

# PART LIST—Model No. 831.6002.1

R0106A

Key No.	Qty.	Description	Key No.	Qty.	Description
1	1	Frame	45	2	Cable Bearing
2	1	Frame Handle	46	2	Inner C-clip
3	2	Stabilizer	47	2	Coupler
4	2	Weight Bumper	48	4	M12 Washer
5	4	Weight Guide Spacer	49	2	Outer C-clip
6	1	Left Side Cover	50	4	Rubber Foot
7	1	Right Side Cover	51	8	M4 x 25mm Screw
8	1	Frame Handle Pad	52	2	Top Weight Bumper
9	2	Handle	53	2	M5 x 25mm Screw
10	2	Cable Clip	54	2	M10 Star Washer
11	6	Weight Guide Bushing	55	32	M10 Washer
12	1	Weight Pin	56	2	Long Weight Guide Bushing
13	5	20-pound Weight	57	4	M10 x 126mm Button Head Screw
14	9	10-pound Weight	58	8	M10 x 84mm Button Head Screw
15	1	Top Weight	59	4	M6 x 64mm Bolt
16	2	Weight Guide	60	4	M6 Nylon Locknut
17	2	Swivel Arm	61	2	M10 x 50mm Button Head Screw
18	2	Trunnion	62	2	M4 x 15mm Screw
19	1	Left Arm	63	28	M10 Nylon Locknut
20	1	Right Arm	64	10	M10 x 50mm Bolt
21	2	38mm x 14mm Spacer	65	2	M10 x 40mm Bolt
22	2	Counterweight	66	2	M6 x 15mm Button Screw
23	1	Left Adjustment Bracket	67	4	M10 x 105mm SHC Screw
24	1	Right Adjustment Bracket	68	4	M12 Nylon Locknut
25	2	38mm x 30mm Spacer	69	4	Plastic Spacer
26	4	16mm x 23mm Spacer	70	2	Bungee Cord Attachment
27	4	16mm x 42mm Spacer	71	2	M12 x 38mm Button Head Screw
28	4	Pulley Plate	72	2	M12 x 52mm Button Head Screw
29	2	Pulley Disc	73	4	M8 x 48mm Button Head Screw
30	18	10-pound Weight Bushing	74	4	M8 Washer
31	4	Spacer Cap	75	8	M5 x 8mm Button Screw
32	2	Knob	76	2	M10 x 95mm Bolt
33	1	Cable	77	2	M10 x 60mm Bolt
34	10	115mm Pulley	78	6	Cable Trap
35	2	90mm Pulley	79	4	50mm Washer
36	2	Coupler Cover	80	2	Magnetic Strip
37	2	Cable Eye	81	4	M6 Washer
38	1	Shroud	82	1	Ankle Strap
39	2	Bungee Cord	83	4	Foot Spacer
40	4	Pulley Arm Bearing	84	2	M10 Lock Washer
41	2	Top Weight Top Bushing	#	1	User's Manual
42	2	Top Weight Bottom Bushing	#	1	Exercise Guide
43	10	20-pound Weight Bushing	#	5	Allen Wrench
44	4	M10 Nut	#	3	Grease Pack

Note: “#” indicates a non-illustrated part. Specifications are subject to change without notice. See the back cover of the user's manual for information about ordering replacement parts.

# EXPLODED DRAWING—Model No. 831.6002.1

R0106A

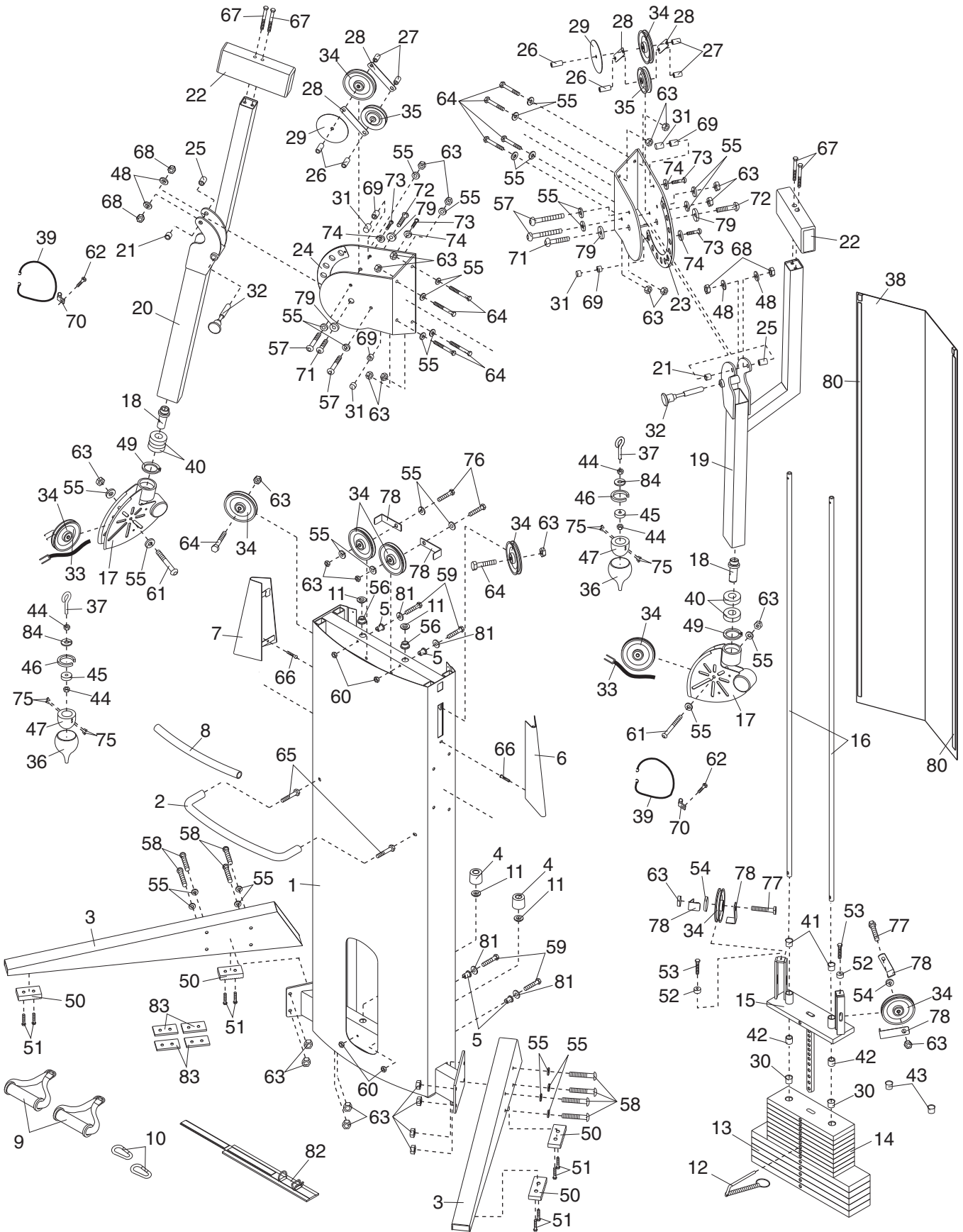

---

# ORDERING REPLACEMENT PARTS

To order replacement parts, please see the front cover of this manual. To help us assist you, be prepared to provide the following information:

- the MODEL NUMBER of the product (831.6002.1)
- the NAME of the product (NordicTrack CABLE CROSS weight system)
- the SERIAL NUMBER of the product (see the front cover of this manual)
- the KEY NUMBER and DESCRIPTION of the part(s) (see the PART LIST and the EXPLODED DRAWING on pages 10 and 11)

---

## LIMITED WARRANTY

**WHAT IS COVERED**—The entire NordicTrack CABLE CROSS weight system (“Product”) is warranted to be free of all defects in material and workmanship.

**WHO IS COVERED**—The original purchaser or any person receiving the Product as a gift from the original purchaser.

**HOW LONG IS IT COVERED**—ICON Health & Fitness, Inc. (“ICON”), warrants the product for one year after the date of purchase. Labor is covered for one year.

**WHAT WE DO TO CORRECT COVERED DEFECTS**—We will ship to you, without charge, any replacement part or component, providing the repairs are authorized by ICON first and are performed by an ICON trained and authorized service provider, or, at our option, we will replace the Product.

**WHAT IS NOT COVERED**—Any failures or damage caused by unauthorized service, misuse, accident, negligence, improper assembly or installation, alterations, modifications without our written authorization or by failure on your part to use, operate, and maintain as set out in your User’s Manual (“Manual”).

**WHAT YOU MUST DO**—Always retain proof of purchase, such as your bill of sale; store, operate, and maintain the Product as specified in the Manual; notify our Customer Service Department of any defect within 10 days after discovery of the defect; as instructed, return any defected part for replacement or, if necessary, the entire product, for repair.

**USER’S MANUAL**—It is VERY IMPORTANT THAT YOU READ THE MANUAL before operating the Product. Remember to do the periodic maintenance requirements specified in the Manual to assure proper operation and your continued satisfaction.

**HOW TO GET PARTS AND SERVICE**—Simply call our Customer Service Department at 1-888-825-2588 and tell them your name and address and the serial number of your Product. They will tell you how to get a part replaced, or if necessary, arrange for service where your Product is located or advise you how to ship the Product for service. Before shipping, always obtain a Return Authorization Number (RA No.) from our Customer Service Department; securely pack your Product (save the original shipping carton if possible); put the RA No. on the outside of the carton and insure the product. Include a letter explaining the product or problem and a copy of your proof of purchase if you believe the service is covered by warranty.

ICON is not responsible or liable for indirect, special or consequential damages arising out of or in connection with the use or performance of the product or damages with respect to any economic loss, loss of property, loss of revenues or profits, loss of enjoyment or use, costs of removal, installation or other consequential damages of whatsoever nature. Some states do not allow the exclusion or limitation of incidental or consequential damages. Accordingly, the above limitation may not apply to you.

The warranty extended hereunder is in lieu of any and all other warranties and any implied warranties of merchantability or fitness for a particular purpose is limited in its scope and duration to the terms set forth herein. Some states do not allow limitations on how long an implied warranty lasts. Accordingly, the above limitation may not apply to you.

No one is authorized to change, modify or extend the terms of this limited warranty. This warranty gives you specific legal rights and you may have other rights which vary from state to state.

**ICON HEALTH & FITNESS, INC., 1500 S. 1000 W., LOGAN, UT 84321-9813**