

10. Specifications

Input Voltage: AC90-260V 50/60Hz

LED Quantities: 1*150W High brightness white LED unit

Control Signal: DMX512, master-slave and sound activated or auto operation

Control Channel: 16 DMX Channels

Power Consumption: 220W

Dimensions: 278(D)x 321(W)x547(H)mm

Packing Dimensions: 495(D)x415(W)x660(H)mm

Net Weight: 13kg

Gross Weight:16kg

11. Maintenance and Cleaning

The following points have to be considered during the inspection:

1. All screws for installing the devices or parts of the device have to be tightly connected and must not be corroded. 2. There must not be any deformations on the housing, color lenses, fixations and installation spots (ceiling, suspension, trussing). 3. Mechanically moved parts must not show any traces of wearing and must not rotate with unbalances. 4. The electric power supply cables must not show any damage, material fatigue or sediments.

Further instructions depending on the installation spot and usage have to be adhered by a skilled installer and any safety problems have to be removed.



CAUTION!

Disconnect from mains before starting maintenance operation.

In order to make the lights in good condition and extend the life time, we suggest a regular cleaning to the lights. 1) Clean the inside and outside lens each week to avoid the weakness of the lights due to accumulation of dust. 2) Clean the fan each week. 3) A detailed electric check by approved electrical engineer each three month, make sure that the circuit contacts are in good condition, prevent the poor contact of circuit from overheating.

We recommend a frequent cleaning of the device. Please use a moist, lint- free cloth. Never use alcohol or solvents. There are no serviceable parts inside the device. Please refer to the instructions under "Installation instructions". Should you need any spare parts, please order genuine parts from your local dealer.



IS200-MH

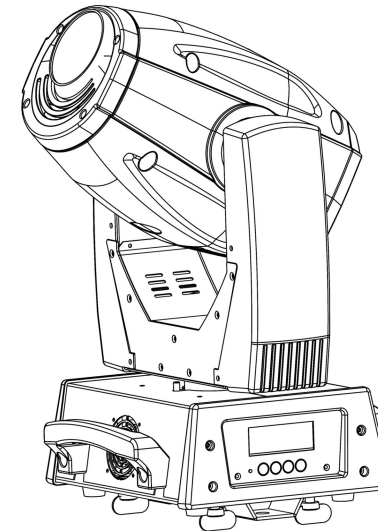

User Manual

KEEP THIS MANUAL FOR FUTURE NEEDS

1. Unpacking

Thank you for choosing Dialighting's IS200-MH. For your own safety, please read this manual before installing the device. This manual covers the important information on installation and applications. Please install and operate the fixture with following instructions. Meanwhile, please keep this manual well for future needs.

Dialighting's IS200-MH is made of a new type of high temperature strength of engineering plastics and cast aluminum casing with nice outlook. The fixture is designed and manufactured strictly following CE standards, complying with international standard DMX512 protocol. It's available independently controlled and linkable with each other for operation. And it is applicable for large-scale live performances, theater, studio, nightclubs and discos.

IS200-MH adopts powerful 150W pure white LED which features high brightness and stability. Please carefully unpack it when you receive the fixture and check whether it is damaged during the transportation. And please check whether the following items are included inside the box:

Moving Head-----one	Signal Cable----one
Omega Clamp-----Two	Power Cable----one
Safety Chain-----One	User Manual----one

				160-179	Internal program 4
				180-199	Internal program 5
				200-219	Internal program 6
				220-239	Internal program 7
				240-255	Internal program 8

9. Key Features

High power 150W white LED unit with light output less than 750W fixture but higher than 575W.

1147FC/12350LUX (2.5m), 277FC/2985LUX (5m), 123FC/1322LUX(7.5m)

50,000 hours lifespan and low power consumption

16 bit smooth and precise resolution for PAN/TILT movement

540°/630° pan and 270° tilt movement

Scan position memory, auto reposition after unexpected movement

1 color wheel with 7 dichroic colors plus open

Variable direction rainbow effect with speed adjustable

1 rotatable gobo wheel with 7 rotatable, interchangeable and indexable gobos plus open (2 metal gobos and 5 glass gobos) with speed adjustable, stream effect, dithering effect and rotatable clockwise or anticlockwise

Gobo indexing function

1 static gobo wheel with 9 gobos plus open

1 prism wheel with 3-facet prism, 5-facet prism and front filter plus open with speed adjustable and variable direction

2 meter to infinite electric focus

15° projection beam angle

Improved optics and flat beam field

Electronic linear IRIS

0-100% linear dimmer with 1-18 times/sec high speed electronic strobe

LED shutter with variable speed

16 DMX channels

Other DMX modes available

DMX512, master-slave and sound activated controllable or auto operation (8 built-in programs)

9	7	1	Shutter	064-095	Strobe effect slow to fast
				096-127	Shutter open
				128-159	Pulse-effect in sequences
				160-191	Shutter open
				192-223	Random strobe effect slow to fast
				224-255	Shutter open
10	8	2	Dimmer	0-255	0-100% Linear dimmer
11	9	8	Focus	0-255	In(near) to out(far)
12	10	9	Prism, Frost	0-063	OFF
				064-127	3 Facet Prism
				128-191	5 Facet Prism
				192-255	Frost
13	11	10	Rotating Prism	0-063	Prism rotation stop
				064-127	Forwards rotation from fast to slow
				128-191	Prism rotation stop
				192-255	Backwards rotation from slow to fast
14	12	7	Iris	0-191	Max. diameter to Min.diameter
				192-223	Pulse opening fast to slow
				224-255	Pulse closing slow to fast
15	13	13	Speed of Pan/Tilt	0-225	Max to min speed
				226-235	Blackout by movement
				236-245	Blackout by all wheel changing
				246-255	No function
16	14	14	Special	0-019	No function
				020-029	No function
				030-039	No function
				040-079	No function
				080-099	Motor reset
				100-119	Internal program 1
				120-139	Internal program 2
				140-159	Internal program 3

2. Safety Instructions



CAUTION!

Be careful with your operations. With a dangerous voltage you can suffer a dangerous electric shock when touching wires!

This device has left the factory in perfect condition. In order to maintain this condition and to ensure a safe operation, it is absolutely necessary for the user to follow the safety instructions and warning notes written in this user manual.



Important:

Damages caused by the disregard of this user manual are not subject to warranty. The dealer will not accept liability for any resulting defects or problems.

If the device has been exposed to temperature changes due to environmental changes, do not switch it on immediately. The arising condensation could damage the device. Leave the device switched off until it has reached room temperature.

This device falls under protection-class I. Therefore it is essential that the device be earthed.

The electric connection must carry out by qualified person.

The device shall only be used with rate voltage and frequency.

Make sure that the available voltage is not higher than stated at the end of this manual.

Make sure the power cord is never crimped or damaged by sharp edges. If this would be the case, replacement of the cable must be done by an authorized dealer.

Always disconnect from the mains, when the device is not in use or before cleaning it. Only handle the power cord by the plug. Never pull out the plug by tugging the power cord.

During initial start-up some smoke or smell may arise. This is a normal process and does not necessarily mean that the device is defective, it should decrease gradually.

Please don't project the beam onto combustible substances.

Fixtures cannot be installed on combustible substances, keep more than 50cm distance with wall for smooth air flow, so there should be no shelter for fans and ventilation for heat radiation.

If the external flexible cable or cord of this luminaire is damaged, it shall be exclusively replaced by the manufacturer or his service agent or a similar qualified person in order to avoid a hazard.

3. Operation Instructions

-The moving head is for beam effect for on-site decoration purpose.

-Don't turn on the fixture if it's been through severe temperature difference like after transportation because it might damage the light due to the environment changes. So make sure to operate the fixture until it is in normal temperature.

- This light should be keep away from strong shaking during any transportation or movement.
- Don't pull up the light by only the head, or it might cause damages to the mechanical parts.
- Don't expose the fixture in overheat, moisture or environment with too much dust when installing it. And don't lay any power cables on the floor. Or it might cause electronic shock to the people.
- Make sure the installation place is in good safety condition before installing the fixture.
- Make sure to put the safety chain and check whether the screws are screwed properly when installing the fixture.
- Make sure the lens are in good condition. It's recommended to replace the units if there are any damages or severe scratch.
- Make sure the fixture is operated by qualified personnel who knows the fixture before using.
- Keep the original packages if any second shipment is needed.
- Don't try to change the fixtures without any instruction by the manufacturer or the appointed repairing agencies.
- It is not in warranty range if there are any malfunctions from not following the user manual to operate or any illegal operation, like shock short circuit, electronic shock, lamp broke, etc.

4. Mounting and Installation

Cautions: For added protection mount the fixtures in areas outside walking paths, seating areas, or in areas were the fixture might be reached by unauthorized personnel.

Before mounting the fixture to any surface, make sure that the installation area can hold a minimum point load of 10 times the device' s weight.

Fixture installation must always be secured with a secondary safety attachment, such as an appropriate safety cable.

Never stand directly below the device when mounting, removing, or servicing the fixture from a ceiling, or set on a flat level surface (see illustration below). Be sure this fixture is kept at least 0.5m (1.5 ft) away from any flammable materials (decoration etc.).

Always use and install the supplied safety cable as a safety measure to prevent accidental damage and/or injury in the event the clamp fails.

Mounting points: Overhead mounting requires extensive experience, including amongst others calculating working load limits, a fine knowledge of the installation material being used, and

				160-179	Gobo 5 shake slow to fast
				180-199	Gobo 6 shake slow to fast
				200-219	Gobo 7 shake slow to fast
				220-255	Rot. gobo wheel cont. rotation slow to fast
7	5	5	Gobo 1 Rot.	0-127	Gobo indexing
				128-189	Forwards gobo rotation from fast to slow
				190-193	Gobo rotation stop
				194-255	Backwards gobo rotation from slow to fast
8	6	6	Gobo 2	0-009	Open/hole
				010-019	Gobo 1
				020-029	Gobo 2
				030-039	Gobo 3
				040-049	Gobo 4
				050-059	Gobo 5
				060-069	Gobo 6
				070-079	Gobo 7
				080-089	Gobo 8
				090-099	Gobo 9
				100-111	Gobo 1 shake slow to fast
				112-123	Gobo 2 shake slow to fast
				124-135	Gobo 3 shake slow to fast
				136-147	Gobo 4 shake slow to fast
				148-159	Gobo 5 shake slow to fast
				160-171	Gobo 6 shake slow to fast
				172-183	Gobo 7 shake slow to fast
				184-195	Gobo 8 shake slow to fast
				196-207	Gobo 9 shake slow to fast
208-255	Gobo wheel rotation from slow to fast				
				0-031	Shutter closed
				032-063	shutter open

8.DMX Channels

Mode/Channel			Function	Values	Description
16B	8B	DE			
1	1	11	Pan	0-255	PAN Movement
2			Pan Fine	0-255	Fine control of Pan movement
3	2	12	Tilt	0-255	Tilt Movement
4			Tilt Fine	0-255	Fine control of Tilt movement
5	3	3	Color	0-015	Open/White
				016-031	Color 1
				032-047	Color 2
				048-063	Color 3
				064-079	Color 4
				080-095	Color 5
				096-111	Color 6
				112-127	Color 7
				128-189	Forwards rainbow effect from fast to slow
				190-193	Color rotation stop
194-255	Backwards rainbow effect from slow to fast				
6	4	4	Gobo 1	0-009	Open
				010-019	Gobo 1
				020-029	Gobo 2
				030-039	Gobo 3
				040-049	Gobo 4
				050-059	Gobo 5
				060-069	Gobo 6
				070-079	Gobo 7
				080-099	Gobo 1 shake slow to fast
				100-119	Gobo 2 shake slow to fast
				120-139	Gobo 3 shake slow to fast
				140-159	Gobo 4 shake slow to fast

periodic safety inspection of all installation material and the fixture. If you lack these qualifications, do not attempt the installation yourself. Improper installation can result in bodily injury.

Be sure to complete all rigging and installation procedures before connecting the main power cord to the appropriate wall outlet.

Clamp Mounting: The IS200-MH provides a unique mounting bracket assembly that integrates the bottom of the base, the included "Omega Bracket," and the safety cable rigging point in one unit (see the illustration below). When mounting this fixture to truss be sure to secure an appropriately rated clamp to the included omega bracket using a M10 screw fitted through the center hole of the "omega bracket". As an added safety measure be sure to attached at least one properly rated safety cable to the fixture using on of the safety cable rigging point integrated in the base assembly

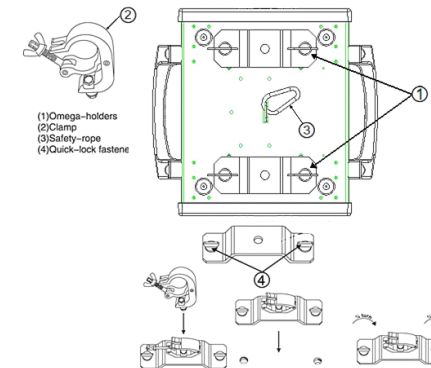

Regardless of the rigging option you choose for your IS200-MH, always be sure to secure your fixture with a safety cable. The fixture provides a built-in rigging point for a safety cable on the hanging bracket as illustrated above. Be sure to only use the designated rigging point for the safety cable and never secure a safety cable to a carrying handle.

5. DMX-512 control connections

Connect the provided XLR cable to the female 3-pin XLR output of your controller and the other side to the male 3-pin XLR input of the moving head. You can chain multiple Moving head together through serial linking. The cable needed should be two core, screened cable with XLR input and output connectors. Please refer to the diagram below.

DMX-512 connection with DMX terminator

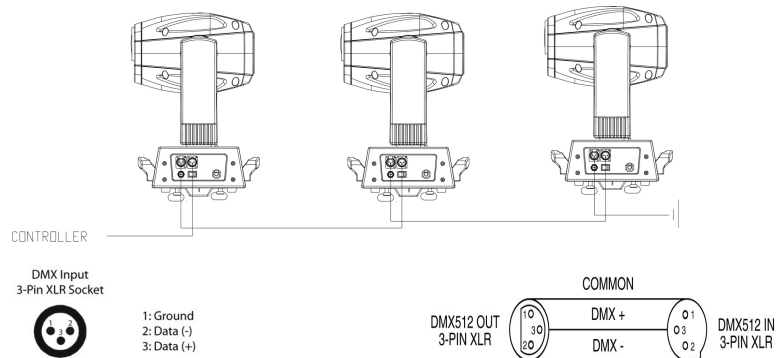

For installations where the DMX cable has to run a long distance or is in an electrically noisy environment, such as in a discotheque, it is recommended to use a DMX terminator. This helps in preventing corruption of the digital control signal by electrical noise. The DMX terminator is simply an XLR plug with a 120 Ω resistor connected between pins 2 and 3, which is then plugged into the output XLR socket of the last fixture in the chain. Please see illustrations below.

6. Photometric Data

Photometric Beam Angle Data

15° Beam Angle
LUX × 0.0929 = FC

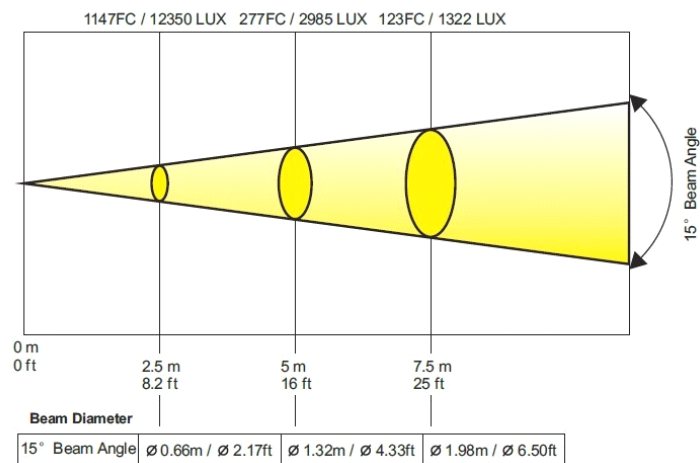

7. Menu Operations

Function Mode	DMX Address	A001~Axxx		
	Set to slave			
	Auto Run	Internal Program1~8	Master/Alone	
	Music Control	Internal Program1~8	Master/Alone	
Reset	On/Off			
Reverse Pan	On/Off			
Reverse Tilt	On/Off			
Mic sensitivity	0~99%			Sensitivity of mic
Special	Reset Default	On/Off		
	Calibration	Code (Code: 088)		
		PAN, TILT, Color Wheel, Gobo Wheel 1, Gobo Wheel 2, Focus, Prism		
	Temperature	XXX°C/°F		
	Manual Control	PAN=XXX.....		
Edit Program	Program1	Steps(1..48)		
	.. Program8	Scenes 01 .. Scenes XX	Pan=XXX... ... Time=xx.xS	Set each scenes' value and time
Mode of channel	Mode Set	16Bit Mode 8Bit Mode Design Mode		
	Design Mode Set	Max Channel = XX PAN = 001 ..		000:Prohibited channel
Version	V1.0~V9.9			