



GP-C830/GP-M830/GP-C831/GP-M831/GP-C832/GP-M832

User's Guide

BPS0139-02 EN

Contents

Chapter 1 **Getting to Know Your Printer**

Features.	7
-------------------	---

Chapter 2 **Safety Instructions**

Safety Instructions.	8
Warnings, Cautions, and Notes.	8
Important safety instructions.	8
For Turkish users.	12
For Ukrainian users.	12
For Brazilian users.	12
For Argentina users.	13

Chapter 3 **Paper Handling**

Acceptable Paper Conditions.	15
Printing on Continuous Paper.	15
Printing with the push tractor.	16
Using the tear-off function.	20
Loading Special Paper.	22
Labels.	22
Using the Micro Adjust Function.	23
Adjusting the tear-off position.	23
Adjusting the top-of-form position.	24

Chapter 4 **Printer Software**

About Your Printer Software.	26
Using the Printer Driver.	26
Accessing the printer driver from Windows applications.	27
Accessing the printer driver from the Start menu.	27
Changing the printer driver settings.	28
Printing barcodes.	28

Printer Driver Settings Overview.	29
Printer settings.	30
Monitoring settings.	31
Using EPSON Status Monitor 3.	32
Setting up EPSON Status Monitor 3.	32
Accessing EPSON Status Monitor 3.	34
Setting the Auto Tear-Off Function.	35
Setting the Buzzer.	35
Setting whether the buzzer sounds when printing is finished.	35
Setting whether the buzzer sounds when an error occurs.	36
Using Reduce Scraping Mode.	36
Adjusting the Print Position.	36
USB Replacement Service.	37
Installing USB Replacement Service.	37
Replacing a USB-connected printer.	38
BI Parallel Port Driver.	38
EpsonNet Config.	39
Installing EpsonNet Config.	40
EPSON Printer Setting.	41
Setting Up Your Printer on a Network.	41
Sharing the printer.	41
Setting up your printer as a shared printer.	42
Setting the clients.	45
Canceling Printing.	47
Using the printer button.	47
Using Windows.	47
Uninstalling the Printer Software.	48
Uninstalling the printer driver and utilities.	48

Chapter 5 Control Panel

Using the Control Panel.	51
Control panel buttons and lights.	51

Chapter 6 Troubleshooting

Using the Error Indicators.	55
Problems and Solutions.	57

Power supply.	57
Printing.	57
Paper handling.	60
Network problems.	61
Other problems.	61
Correcting USB Problems.	61
Make sure that your computer is a Windows 8, 7, Vista, XP, or 2000 pre-installed model.	62
Printer does not work correctly with the USB cable.	62
Clearing Paper Jams.	62

Chapter 7 Where To Get Help

Technical Support Web Site.	64
Contacting Customer Support.	64
Before Contacting Epson.	64
Help for Users in Australia.	65
Help for Users in Singapore.	66
Help for Users in Thailand.	66
Help for Users in Indonesia.	66
Help for Users in Hong Kong.	66
Help for Users in Malaysia.	67
Help for Users in India.	67
Help for Users in the Philippines.	67
Help for Users in Europe.	68
Help for Users in North America.	68
Help for Users in Latin America.	69

Chapter 8 Consumables

Replacing the Ink Cartridges.	71
Genuine Epson ink cartridges.	71
Checking the ink cartridge status.	71
Precautions on ink cartridge replacement.	73
Replacing an ink cartridge.	75

Chapter 9 Product Information

Printer Parts.	80
------------------------	----

Printer Specifications.	81
Mechanical.	81
Electronic.	83
Electrical.	88
Environmental.	89
Paper.	89
Printable area.	92
AC Adapter Electrical Specifications.	93
Command Lists.	94
Character Tables.	94
Standards and Approvals.	95
Taiwan.	96
North America.	96
Europe.	97
Checking the Print Head Nozzles.	97
Using the Nozzle Check utility for Windows.	97
Using the control panel.	98
Cleaning the Print Head.	99
Using the Head Cleaning utility for Windows.	99
Using the control panel.	100
Aligning the Print Head.	101
Adjusting the media feed.	101
Adjusting the bi-directional printing.	101
Printing the Status Sheet.	102
General information.	102
Network settings.	103
Printer settings.	103
Initializing the Network Setting.	103
Cleaning the Printer.	103
Cleaning the outer case.	104
Cleaning the inside of the printer.	104
Cleaning the paper feed rollers.	106
Transporting the Printer.	107

Copyright and Trademarks

Operating System Versions

Index

Chapter 1

Getting to Know Your Printer

Features

Your EPSON® GP-C830/GP-M830/GP-C831/GP-M831/GP-C832/GP-M832 is an ink jet printer with a tractor feeder. Your printer provides high-quality printing and superior performance in a compact design. The printer has the following features:

- ❑ The ability to handle a wide range of paper types, including continuous medicine bags, labels (continuous base sheet), continuous plain paper, and other paper with sprocket holes.
- ❑ The ability to use individual, large-capacity ink cartridges. Durable design for high-volume printing.
- ❑ The pigment inks that are used achieve high-quality printing on plain paper and have excellent waterproof capability.

Your printer comes packaged with the printer driver and other software, including the EPSON Status Monitor 3 utility for Microsoft Windows 8, 7, Vista, XP, Server 2012, Server 2008 R2, Server 2008, and Server 2003. The EPSON Status Monitor 3 utility lets you check the status of your printer quickly and easily.

Chapter 2

Safety Instructions

Safety Instructions

Warnings, Cautions, and Notes

**Warnings**

must be followed carefully to avoid bodily injury.

**Cautions**

must be observed to avoid damage to your equipment.

Notes

contain important information and useful tips on the operation of your printer.

Important safety instructions

Read all of these safety instructions before using the printer. In addition, follow all warnings and instructions marked on the printer itself.

When setting up the printer

**Warning:**

Use the specified AC Adapter (EPSON AC Adapter K, Model: M248A) only.

- Do not place the printer on an unstable surface or near a radiator or heat source.
- Place the printer on a flat, stable surface. Tilting or placing the printer at an angle may adversely affect the print quality.
- Do not place the printer on a soft, unstable surface like a bed or a sofa, or in a small, enclosed area, as this restricts ventilation.
- Do not block or cover the slots and openings in the printer's cabinet, and do not insert objects through the slots.
- Leave adequate room around the printer for easy operation and maintenance.

- Place the printer where you can easily connect it to a interface cable, if necessary.
- Use only the type of power source indicated on the printer's label. If you are not sure of the power supply specifications in your area, contact your local power company or consult your dealer.
- Connect all equipment to properly grounded electrical outlets. Avoid using outlets on the same circuit as photocopiers or air control systems that regularly switch on and off.
- Do not use a damaged or frayed power cord.
- The power cord should be placed to avoid abrasions, cuts, fraying, crimping, kinking, and other damage.
- If you use an extension cord with the printer, make sure the total ampere rating of all devices plugged into the extension cord does not exceed the cord's ampere rating. Also, make sure the total ampere of all devices plugged into the electrical outlet does not exceed the electrical outlet's ampere rating.
- Use only the power cord that comes with this product. Use of another cord may result in fire or electric shock.
- This product's power cord is for use with this product only. Use with other equipment may result in fire or electric shock.
- Be sure the AC power cord meets the relevant local safety standards.
- Depending on the area, the interface cable may be included with the product. If so, use that cable.
- Seiko Epson Corporation shall not be held liable for any damage resulting from electromagnetic interference that occurs from the use of any interface cables other than those designated as Epson approved products. For details about approved cables, contact Epson customer support.
- Avoid using or storing the printer in places subject to rapid changes in temperature and humidity. Also, keep it away from direct sunlight, strong light, heat sources, or excessive moisture or dust.
- Avoid places subject to shocks and vibrations.
- Place the printer near a wall outlet where you can easily unplug the power cord.
- Keep the entire computer system away from potential sources of electromagnetic interference, such as loudspeakers or the base units of cordless telephones.
- Avoid electrical outlets controlled by wall switches or automatic timers. An interruption in power can erase information in the memory of your printer or computer. Also, avoid outlets on the same circuit as large motors or other appliances that can cause voltage fluctuations.
- Use a grounded power outlet; do not use an adapter plug.

- ❑ If you plan to use a printer stand, follow these guidelines:
 - Use a stand that can support at least twice the weight of the printer.
 - Never use a stand that tilts the printer. The printer should always be kept level.
 - Position your printer's power cord and interface cable so they do not interfere with paper feeding. If possible, secure the cables to a leg of the printer stand.

When maintaining the printer

- ❑ Unplug the printer before cleaning it, and always clean it with a damp cloth only.
- ❑ Do not spill liquid onto the printer.
- ❑ Do not attempt to service the printer yourself except as specifically explained in this manual.
- ❑ Unplug the printer and refer servicing to qualified service personnel under the following conditions:
 - i. If the power cord or plug is damaged.
 - ii. If liquid has entered the printer.
 - iii. If the printer has been dropped or the cabinet damaged.
 - iv. If the printer does not operate normally or exhibits a distinct change in performance.
- ❑ Do not use aerosol blowers which contain flammable gas inside or around this product. Doing so may cause fire.
- ❑ Adjust only those controls that are covered in this manual.

When handling paper

Do not load paper that is curled or has been folded.

When operating the printer

- ❑ Adjust only those controls that are covered in the user documentation. Improper adjustment of other controls may result in damage requiring extensive repair by a qualified technician.
- ❑ When the printer encounter difficulties, turn off the printer, and then unplug the power cord from the electrical outlet.

When handling ink cartridges

Observe the following when handling ink cartridges:

- ❑ Keep ink cartridges out of the reach of children and do not drink the ink.

- ❑ If ink gets on your skin, wash it off with soap and water. If it gets in your eyes, flush them immediately with water.
- ❑ For best results, shake the ink cartridge four or five times.

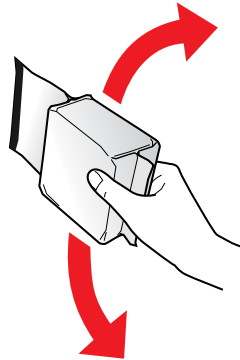
**Caution:**

Do not shake cartridges (that have been installed previously) with too much force.

- ❑ Use an ink cartridge prior to the date printed on the cartridge carton.
- ❑ Use up the ink cartridge within six months of installation for best results.
- ❑ Do not disassemble or modify the ink cartridge; otherwise, you may not be able to print normally.
- ❑ Store ink cartridges in a cool, dark place.
- ❑ After bringing an ink cartridge inside from a cold storage site, allow it to warm up at room temperature for at least three hours before using it.
- ❑ Do not touch the green IC chip on the side of the cartridge. This may affect normal operation and printing. The IC chip on this ink cartridge retains a variety of cartridge related-information, such as the ink cartridge status, so that the cartridge may be removed and reinserted freely. If you remove an ink cartridge for later use, protect the ink supply area from dirt and dust, and store it in the same environment as this product. Note that there is a valve in the ink supply port, making covers or plugs unnecessary, but care is needed to prevent the ink from staining items that the cartridge touches. Do not touch the ink supply port or surrounding area.

Restriction of use

When this product is used for applications requiring high reliability/safety, such as transportation devices related to aviation, rail, marine, automotive, etc.; disaster prevention devices; various safety devices, etc.; or functional/precision devices, etc., you should use this product only after giving consideration to including fail-safes and redundancies into your design to maintain safety and total system reliability. Because this product was not intended for use in applications requiring extremely high reliability/safety such as aerospace equipment, main communication equipment, nuclear power control equipment, or medical equipment related to direct medical care etc., please make your own judgment on this product's suitability after a full evaluation.

For Turkish users

AEEE Yönetmeliğine Uygundur.

For Ukrainian users

Обладнання відповідає вимогам Технічного регламенту обмеження використання деяких небезпечних речовин в електричному та електронному обладнанні.

For Brazilian users

A Epson preocupa-se com o meio ambiente e sabe que o planejamento para o futuro requer um forte compromisso ambiental. Para isso, nos empenhamos em criar produtos inovadores que são confiáveis, recicláveis e eficientes. Produtos melhores utilizando menos recursos naturais para ajudar a garantir um futuro melhor para todos.

As embalagens deste produto - papelão, plástico, isopor e espuma - são recicláveis e podem ser entregues a cooperativas de reciclagem, postos de recolhimento de resíduos ou empresas recicladoras.

Os materiais que compõem o produto - plástico, metais, placa eletrônica e cartucho - são recicláveis. O produto não deve ser desmontado, deve ser encaminhado para os Centros de Serviços Autorizados que darão o destino ambientalmente adequado. Consulte em nosso site - <http://global.latin.epson.com/br> os Centros de Serviços Autorizados.

Todos os Centros de Serviços Autorizados podem receber equipamentos da marca Epson destinados para reciclagem.

Conheça nossas ações ambientais e o Programa de Coleta de Cartuchos (www.epson.com.br/coleta) em nosso site.

For Argentina users

When handling AC adapter

**Precaución:**

Confirme que el cable de alimentación de CA cumpla con las normas de seguridad locales pertinentes.

- Coloque la impresora y la fuente externa de poder cerca a una toma eléctrica de pared de la que pueda desenchufar la fuente externa de poder fácilmente.
- No coloque el cable de alimentación de CA en lugares donde se pueda enroscar, cortar, desgastar, deshilar o rizar. No coloque ningún objeto sobre el cable de alimentación de CA y no coloque la fuente externa de poder o el cable de alimentación en zonas donde se puedan pisar. Tome especial precaución de no doblar los cables de alimentación en los extremos y en los puntos de entrada de la fuente externa de poder.
- Utilice únicamente la fuente externa de poder suministrada con la impresora. El uso de otro fuente externa de poder podría provocar incendios, descargas eléctricas u otros daños.
- La fuente externa de poder está diseñada para ser utilizada con la impresora a la que acompaña. No intente usarla con otros dispositivos electrónicos, a menos que esté especificado.
- Utilice sólo el tipo de corriente indicado en la etiqueta de la fuente externa de poder. Use siempre tomas de corriente eléctricas, domésticas y estándar con el cable de alimentación que cumplan con las regulaciones locales de seguridad.
- No use tomas de corriente que se encuentren en el mismo circuito que fotocopiadoras o sistemas de aire acondicionado que se enciendan y apaguen periódicamente. Si utiliza un cable de extensión con el impresor, compruebe que la suma de las corrientes nominales en amperios de todos los dispositivos conectados al cable de extensión no sea superior a la corriente nominal de dicho cable. Además, compruebe que el total de amperios de intensidad de todos los dispositivos enchufados a la toma eléctrica de pared no supere el total de amperios de la toma. No coloque varias cargas en la toma eléctrica de la pared.
- Nunca desmonte, modifique o intente reparar Ud. mismo la fuente externa de poder o la impresora.
- No inserte objetos en las aberturas del impresor, pues podrían entrar en contacto con puntos de voltaje peligrosos o provocar cortocircuitos en dichos elementos. Existe el peligro de descargas eléctricas.

- ❑ Desenchufe la impresora y la fuente externa de poder antes de limpiar la impresora. Límpiela sólo con un paño húmedo. No utilice productos de limpieza líquidos o en aerosol. No aplique líquido de ningún tipo directamente al cristal de la impresora.
- ❑ Desenchufe la impresora y la fuente externa de poder y póngase en contacto con un técnico de servicio ante las siguientes situaciones: el cable de CA o el enchufe están estropeados; ha entrado líquido en el impresor o en la fuente externa de poder; la impresora o la fuente externa de poder se han caído o se ha dañado la carcasa; la impresora o la fuente externa de poder no funcionan con normalidad o muestran un cambio en su rendimiento. (No ajuste los controles que no hayan sido especificados en las instrucciones de funcionamiento).
- ❑ Cuando no vaya a utilizar el impresor durante un periodo de tiempo prolongado, desenchufe la fuente externa de poder de la toma eléctrica.

Chapter 3

Paper Handling

Acceptable Paper Conditions

**Caution:**

- ❑ Do not use paper that is folded, creased, curled, torn, stained, or stamped.

- A: Torn
- B: Curled
- C: Creased
- D: Folded

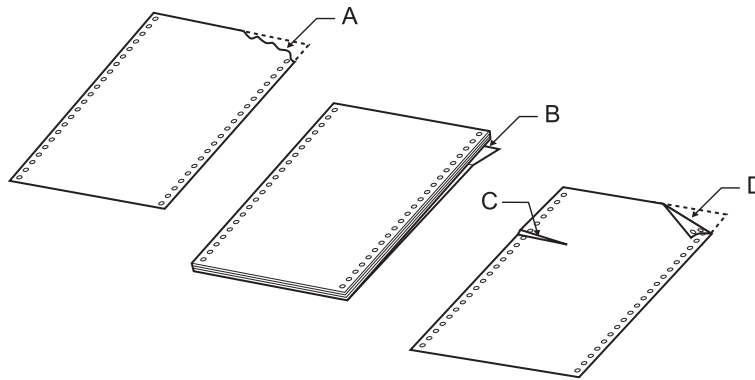

- ❑ Use only paper that meets the paper specifications. For more information, see “Paper” on page 89.

Printing on Continuous Paper

Your printer can handle continuous paper with the push tractor.

Position the printer and continuous paper as shown in the illustrations below so that the paper is loaded smoothly.

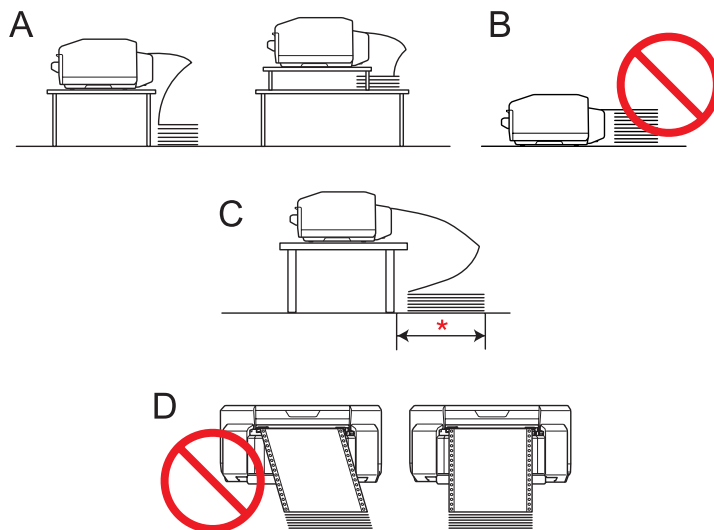

* 1 m or less

Note:

- The printing position may be misaligned if the continuous paper touches the printer's stand or any cables. Position the continuous paper so that it is loaded smoothly. (A)
- Overlapping paper may be fed if the top of the stack of continuous paper is as high as or higher than the push tractor. (B)
- Be sure to remove the continuous paper from its box and place it within 1 m of the printer. (C)
- Load the continuous paper straight into the printer. (D)

Printing with the push tractor

Follow these steps to load continuous paper using the push tractor.

Note:

Do not touch the paper sensor on the left sprocket unit.

1. Turn off the printer.

2. Facing the back of the printer, release the right sprocket unit by pulling the sprocket lock lever up.

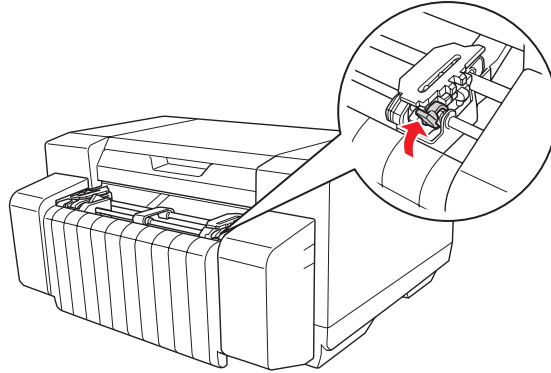

3. Slide the right sprocket to match the width of your paper, but do not lock it.

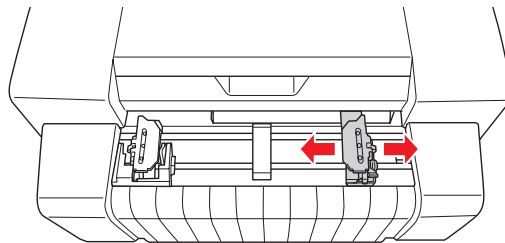

Note:

The left sprocket unit is fixed in place and cannot be adjusted.

4. Slide the center paper support halfway between the two sprockets.

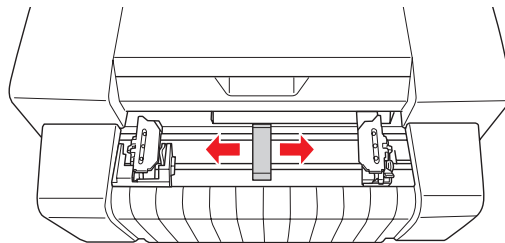

5. Open the sprocket covers of both sprockets.

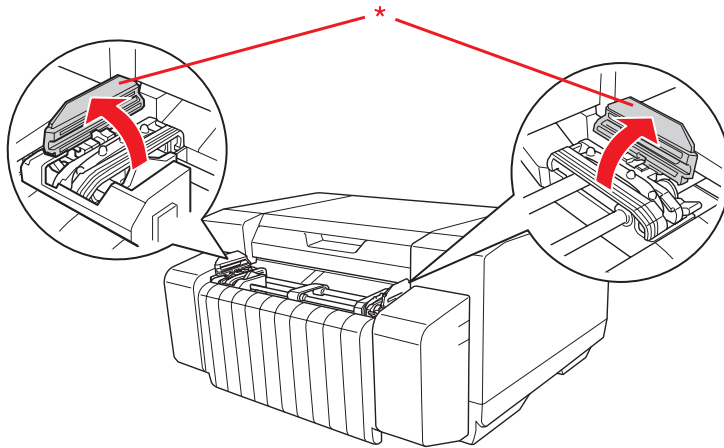

* sprocket cover

6. Fit the first two holes of the paper over the sprocket pins on both sides. Slide the right sprocket unit slightly to the right so that the paper is not slack.

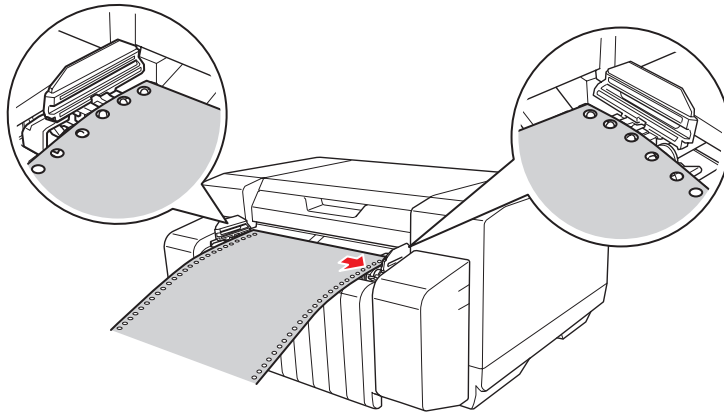

Caution:

Make sure the first sheet of your continuous paper has a clean, straight edge so that it can feed smoothly into the printer.

7. Close the sprocket covers.

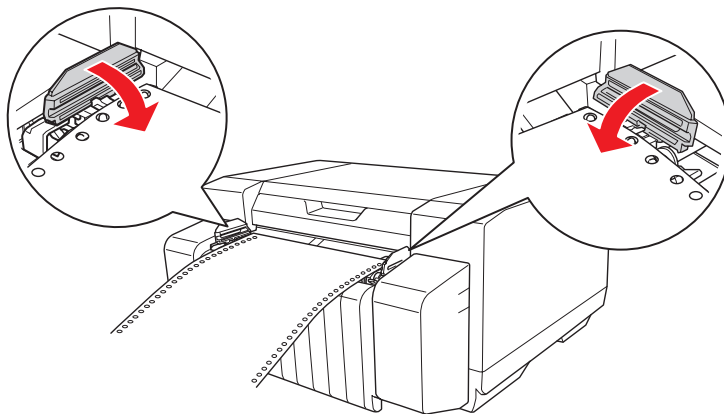

8. Slide the right sprocket unit to remove any slack in the paper and lock it in place.

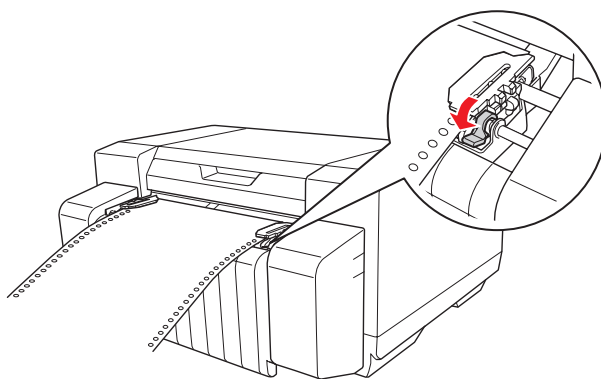

9. Turn on the printer.
10. Press the **Load/Eject** button to feed the paper to the top-of-form position. When the printer receives data, it begins printing.
11. After you finish printing, follow the steps in the next section to tear off your printed document. If the first printed line on your page appears too high or low, you can change its position using the Micro Adjust function. See “Adjusting the top-of-form position” on page 24.

Note:

- ❑ *After you finish printing, tear off your printed document, and then turn off the printer. If you turn the printer off and on without tearing off the printed document, the top-of-form position setting may become misadjusted.*

- ❑ *If the trailing edge of the paper is past the paper sensor after the printed document is torn off, the paper will be fed forward without being printed.*
- ❑ *Do not pull the loaded paper out of the tractor unit. Doing so may cause paper jams or printer malfunctions. Also, the top-of-form position setting may become misadjusted.*
- ❑ *The last page of continuous paper that is printed may have low print quality.*
- ❑ *If the first line on your page appears too high or low, you can change its position using the Micro Adjust function. For more information, see “Adjusting the top-of-form position” on page 24.*
- ❑ *Make sure that the right and left edges of continuous paper are straight and not slack when you load the paper.*
- ❑ *Do not pull the paper while printing. Doing so may adversely affect the print quality.*

**Caution:**

Never open the top cover or ink cartridge cover while printing.

Using the tear-off function

You can use the tear-off function to advance your continuous paper to the printer's tear-off position after you finish printing.

- ❑ To tear off the printed sheet manually after printing, press the **Tear Off** button to advance the perforation of the paper to the tear-off position.
- ❑ To enable the auto tear-off function, turn on the Auto Tearoff Setting from the printer driver. The printer advances the perforation of the paper to the tear-off position automatically when a set time has passed after printing. When the printer receives the print data, the printer feeds the paper backward to the top-of-form position automatically. For more information, see “Setting the Auto Tear-Off Function” on page 35.

If the paper perforation is not in the desired tear-off position, you can use the Micro Adjust function to adjust the position of the perforation. For more information, see “Adjusting the tear-off position” on page 23.

Follow these steps to use the auto tear-off function.

1. After printing is finished and the printer advances the paper to the tear-off position, tear off all printed pages while holding the paper.

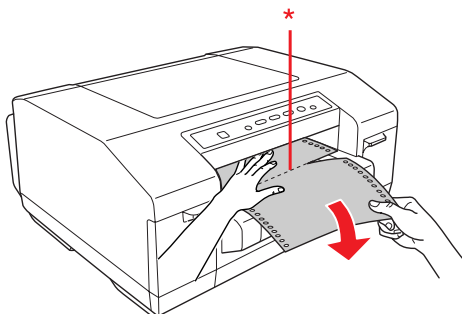

* perforation

Note:

The time until the paper begins to advance to the tear-off position after printing is finished can be set. To change the settings, see “Setting the Auto Tear-Off Function” on page 35.

2. When you resume printing, the printer feeds the paper back to the top-of-form position and begins printing.

Removing continuous paper

Follow these steps to remove continuous paper from the printer.

1. After printing is finished and the printer advances the paper to the tear-off position, tear off all printed pages.
2. Press the **Tear Off** button to feed the paper backward to the top-of-form position.
3. Press the **Load/Eject** button to feed the paper backward out of the printer to the standby position.

Note:

*Do not feed the paper backward 558.8 mm (22 inches) or more using the **Load/Eject** button. Doing so may cause paper jams.*

4. To completely remove the paper from the printer, open the sprocket covers. Remove the paper from the tractor unit, and then close the sprocket covers.

Loading Special Paper

Labels

You can use only labels with a continuous base sheet. Single-sheet labels cannot be used.

Follow these steps to load labels.



Caution:

- Use labels only under normal operating conditions because labels are especially sensitive to temperature and humidity.
 - When using glossy labels, tear off the printed label form and turn off the printer after printing is finished. Do not leave the printed label form connected to the unprinted label forms.
1. Make sure that your software settings keep the printing entirely within the printable area. For information about the printable area, see “Printable area” on page 92.
 2. Load labels as described in “Printing on Continuous Paper” on page 15.

Ejecting labels

Always follow these steps to tear off and eject labels.



Caution:

- Never feed labels backward using the **Load/Eject** button. Labels can easily peel off their backing and jam the printer.*
1. At the back of your printer, tear off the last label form that has entered the printer along the perforation. See the illustration below.

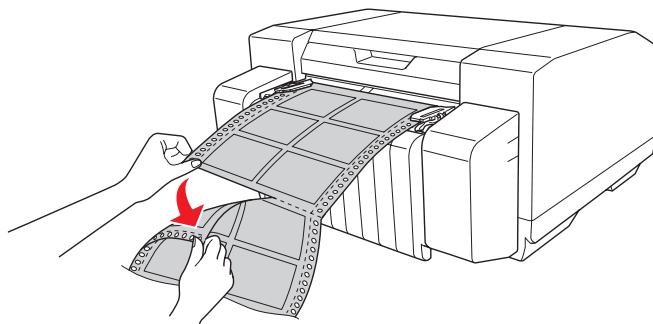

2. Press the **FF** button to eject the last label form forward.

Using the Micro Adjust Function

The Micro Adjust function allows you to move the paper forward or backward in 0.141 mm (1/180-inch) increments so that you can make precise adjustments to the top-of-form and tear-off positions.

Adjusting the tear-off position

If the paper perforation is not in the desired tear-off position, you can use the Micro Adjust function to adjust the position of the perforation.

Follow these steps to adjust the tear-off position.

Note:

Your tear-off position setting remains in effect until you change it, even if you turn off the printer.

1. Make sure the paper is at the current tear-off position.
2. Hold down the **Pause** button for about three seconds. The **Pause** light flashes and the printer enters Micro Adjust mode.
3. Press the **FF** **↓** button to feed the paper forward, or press the **Load/Eject** **↑** button to feed the paper backward, until the paper perforation is in the desired tear-off position.

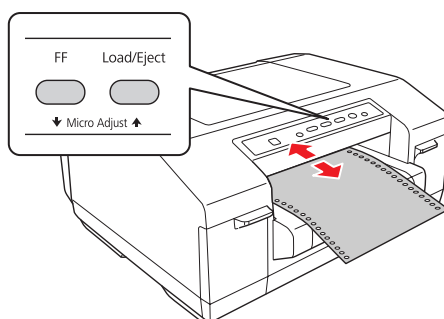

Note:

The printer has a minimum and a maximum tear-off position (up to 50.8 mm [2 inches] backward or 25.4 mm [1 inch] forward). If you try to adjust the tear-off position beyond these limits, the printer beeps and stops moving the paper. When the paper reaches the default tear-off position, the printer also beeps.

4. Tear off the printed pages.
5. Press the **Pause** button to exit Micro Adjust mode.



Adjusting the top-of-form position

The top-of-form position is the position on the page where the printer starts printing. If your printing appears too high or low on the page, you can use the Micro Adjust function to adjust the top-of-form position.

Follow these steps to adjust the top-of-form position.

Note:

- ❑ Your top-of-form position setting remains in effect until you change it, even if you turn off the printer.
- ❑ The top margin setting made in some applications overrides the top-of-form position setting you make with the Micro Adjust function. If necessary, adjust the top-of-form position in your application.

1. Open the top cover.
2. Hold down the **Pause** button for about three seconds. The **Pause** light flashes, the printer enters Micro Adjust mode, and then the paper is advanced to the current top-of-form position.
3. Press the **FF**  button to move the top-of-form position down on the page, or press the **Load/Eject**  button to move the top-of-form position up on the page.

Note:

- ❑ The printer has a minimum and a maximum top-of-form position (up to 23.4 mm [0.921 inches] backward or 50.8 mm [2 inches] forward). If you try to adjust it beyond these limits, the printer beeps and stops moving the paper.
- ❑ When the paper reaches the default top-of-form position, the printer also beeps and stops moving the paper briefly. You can use the default setting as a reference point when adjusting the top-of-form position.

You can adjust the top-of-form position by opening the top cover and aligning the paper with the scale in the printer.

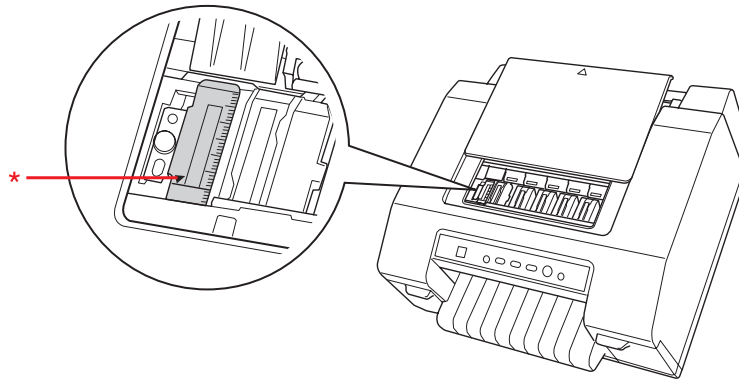

* top-of-form position

4. Press the **Pause** button to exit Micro Adjust mode.

Note:

- If the forward adjustment of the top-of-form position is longer than the page length of the paper that you are using, you cannot print on the page that has been moved forward.*
- If the backward adjustment of the top-of-form position is longer than the page length of the paper that you are using, you cannot print the first part of the document or image.*

Chapter 4

Printer Software

About Your Printer Software

The Epson software includes the printer driver and EPSON Status Monitor 3.

The printer driver is software that allows your computer to control the printer. You need to install the printer driver so your Windows applications can take full advantage of the printer's capabilities.

EPSON Status Monitor 3 allows you to monitor the status of your printer, alerts you when errors occur, and provides you with troubleshooting tips. EPSON Status Monitor 3 is automatically installed when you install the printer driver.

Note:

- ❑ *Before proceeding, make sure you have installed the printer driver on your computer described in the [Start Here](#).*
- ❑ *On-screen displays on the following pages may differ depending on the version of the printer driver.*

Using the Printer Driver

You can access the printer driver from your Windows applications or from the Start menu.

- ❑ When you access the printer driver from a Windows application, any settings you make apply only to the application you are using. For more information, see “Accessing the printer driver from Windows applications” on page 27.
- ❑ When you access the printer driver from the Start menu, the printer driver settings you make apply to all your applications. For more information, see “Accessing the printer driver from the Start menu” on page 27.

To check and change the printer driver settings, see “Changing the printer driver settings” on page 28.

Note:

While many Windows applications override the settings made with the printer driver, some do not. Therefore, you must verify that the printer driver settings match your requirements.

Accessing the printer driver from Windows applications

Follow these steps to access the printer driver from a Windows application.

1. Select **Print Setup** or **Print** from the File menu of your application. In the Print or Print Setup dialog box displayed, make sure that your printer is selected.
2. Click **Preferences**, **Printer Properties**, or **Options**. (The button you click depends on your application and you may need to click a combination of these buttons.) The Document Properties dialog box appears. The Main, Paper, Layout, and Utility menus in the dialog box contain the printer driver settings.
3. To view a menu, click the corresponding tab at the top of the dialog box. To change the settings, see “Changing the printer driver settings” on page 28.

Accessing the printer driver from the Start menu

Follow these steps to access the printer driver from the Start screen or Start menu.

Note:

The screen shots used in this procedure are from Windows XP. They may vary in appearance from what actually appears on your screen; however, the instructions are the same.

1. For Windows 8 or Server 2012:
Click **Desktop** on the Start screen, move the cursor to the top-right corner of the screen, click **Settings**, and then click **Control Panel**. Next, click **View devices and printers** from the **Hardware and Sound** category.

For Windows 7 or Server 2008 R2:
Click **Start**, and then click **Devices and Printers**.

For Windows Vista or Server 2008:
Click **Start**, click **Control Panel**, click **Hardware and Sound**, and then click **Printers**.

For Windows XP Professional or Server 2003:
Click **Start**, and then click **Printers and Faxes**.
2. Right-click your printer icon, and then click **Printing Preferences**. The Printing Preferences dialog box appears. The Main, Paper, Layout, and Utility menus in the dialog box contain the printer driver settings.

If you click **Printer properties** (Windows 8, 7, Server 2012, or Server 2008 R2) or **Properties** (Windows Vista, XP, Server 2008, or Server 2003) in the menu displayed by right-clicking the printer icon, the Properties dialog box appears. The menus in the dialog box are used to make the printer driver settings.

Note:

*For Windows 8, 7, Server 2012, or Server 2008 R2, do not click **Properties** even though both **Properties** and **Printer properties** are displayed in the menu.*

3. To view a menu, click the corresponding tab at the top of the dialog box. To change the settings, see “Printer Driver Settings Overview” on page 29.

Changing the printer driver settings

Your printer driver has three menus (Main, Paper, and Layout) from which you can change the printer driver settings. You can also change settings on the Utility menu in the printer software. For an overview of the available settings, see “Printer Driver Settings Overview” on page 29. To view online help, click **Help** on the Printer Driver dialog box. You can also view online help by right-clicking items in the driver and selecting Help.

When you finish making your printer driver settings, click **OK** to apply the settings, or click **Cancel** to cancel your changes.

Once you have checked your printer driver settings and changed them if necessary, you are ready to print.

Printing barcodes

Barcodes can be easily printed using barcode fonts loaded in the printer driver.

Before printing barcodes, specify the font name for the barcode, the font size, the font script of the printed data, the common settings, and the barcode settings with the printer driver, and then specify the font name, the font size, and the font script with your application. For more information about these settings, see the online help.

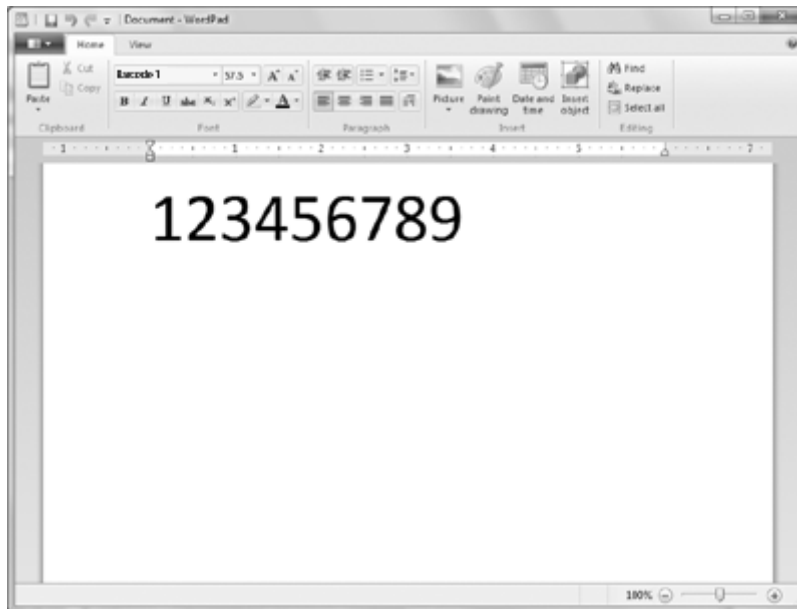

Note:

- Specify the font size that is set with the **Specified Point** for the barcode. If other font sizes are specified, the barcode cannot be printed.
- When printing and using barcodes, make sure that they can be scanned correctly under the actual usage conditions.

Printer Driver Settings Overview

The following tables show the Windows printer driver settings. Note that not every setting is available in all versions of Windows. For more information, see the online help for the printer driver.

Printer settings

Settings	Explanations
Media Type	Select the media type you want to use.
Color	This setting cannot be changed. The GP-C830/GP-C831/GP-C832 can print only in color and the GP-M830/GP-M831/GP-M832 can print only in black and white.
Mode*	Select Automatic to print with the best settings based on the Media Type and Color settings. Select Custom if you prefer to have more control over the printer driver settings. Select Silent Feed to make the operating sound of the printer quiet.
Print Density	This setting allows you to prevent the printout from becoming blurry depending on the media type. Select Custom, click Advanced, and then adjust the print density using the Print Density slider.
Ink Levels	The amount of ink remaining is displayed.
Print Preview	This setting allows you to see a preview of your document before printing it.
Paper Size	Select the size of the paper you want to use. If you do not see your paper size, use the scroll bar to scroll through the list. If your paper size is not included in the list, see "Adding custom paper sizes" on page 31 for instructions. Note: If the width of the paper size set with the printer driver is larger than the width of the loaded paper, the portion of the data that is outside the printable area for the loaded paper is not printed.
Copies*	Specify the number of copies in the Copies box. Select Collate to print multi-page documents in sets. Select Reverse Order to print from back to front.
Orientation	Select Portrait or Landscape. Select Rotate by 180 degrees to print the documents upside down.
Reduce/Enlarge*	These settings allow you to enlarge or reduce the size of a document while maintaining its aspect ratio.
Multi-Page*	These settings allow you to enable the multi-page printing.
Stampmark*	These settings allow you to print documents with the selected stampmark.
Extended Settings	This setting allows you to adjust the print position vertically.

* For more information, see Windows Help.

Adding custom paper sizes

If your paper is not included in the Paper Size drop-down list, you can add the size to the list.

1. For Windows 8 or Server 2012:

Click **Desktop** on the Start screen, move the cursor to the top-right corner of the screen, click **Settings**, and then click **Control Panel**. Next, click **View devices and printers** from the **Hardware and Sound** category.

For Windows 7 or Server 2008 R2:

Click **Start**, and then click **Devices and Printers**.

For Windows Vista or Server 2008:

Click **Start**, click **Control Panel**, click **Hardware and Sound**, and then click **Printers**.

For Windows XP Professional or Server 2003:

Click **Start**, and then click **Printers and Faxes**.

2. Right-click your printer icon, and then click **Printing Preferences**.
3. Click the **Paper** tab.
4. Select **User Defined** for the Paper Size setting.
5. Enter a paper size name in the **Paper Size Name** box.
6. Select **1 mm** or **1 inch** under Unit, and then enter the paper size in the **Paper Width** and **Paper Height** boxes.
7. Click **Save**, and then click **OK**.

Note:

For more information, see the online help for the printer driver.

Monitoring settings

Settings	Explanations
EPSON Status Monitor 3	You can access EPSON Status Monitor 3 when you click this button in the Utility menu. To monitor the printer, make sure the Disables EPSON Status Monitor 3 check box is cleared in the Other Config dialog box.

Settings	Explanations
Monitoring Preferences	Click this button to open the Monitoring Preferences dialog box where you can make settings for EPSON Status Monitor 3. For more information, see "Setting up EPSON Status Monitor 3" on page 32.

Using EPSON Status Monitor 3

EPSON Status Monitor 3 allows you to monitor your printer's status, alerts you when printer errors occur, and provides troubleshooting instructions when needed.

EPSON Status Monitor 3 is available when:

- The printer is connected directly to the host computer using the parallel port [LPTx] or [BILPTx], or the USB port.
- Your system is configured to support bidirectional communication.

EPSON Status Monitor 3 is installed when the printer is connected directly and you install the printer driver as described in the *Start Here*.



Caution:

Although you can print using the printer that is directly connected to the computer from a remote location using the Remote Desktop function of Windows 8, 7, Vista, or XP, communication errors may occur.*

** Remote Desktop function: Function which enables a user to access applications or files on a computer connected to the office network from a mobile computer at a remote location.*

Note:

If you are using a computer running Windows 8, 7, Vista, or XP, a communication error message may be displayed when monitoring printers if multiple users are logged on.

Setting up EPSON Status Monitor 3

Follow these steps to set up EPSON Status Monitor 3.

1. For Windows 8 or Server 2012:
Click **Desktop** on the Start screen, move the cursor to the top-right corner of the screen, click **Settings**, and then click **Control Panel**. Next, click **View devices and printers** from the **Hardware and Sound** category.

For Windows 7 or Server 2008 R2:

Click **Start**, and then click **Devices and Printers**.

For Windows Vista or Server 2008:

Click **Start**, click **Control Panel**, click **Hardware and Sound**, and then click **Printers**.

For Windows XP Professional or Server 2003:

Click **Start**, and then click **Printers and Faxes**.

2. Right-click your printer icon, click **Printing Preferences**, and then click the **Utility** tab.
3. Click **Other Config**, and then click **Monitoring Preferences**. The Monitoring Preferences dialog box appears.

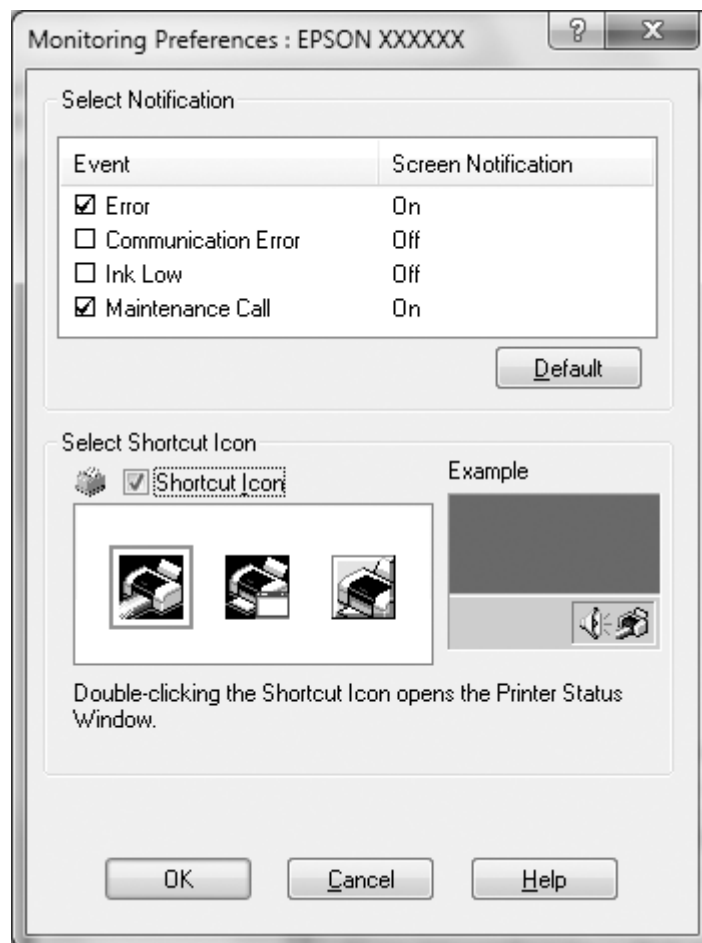

4. The following settings are available:

Select Notification	Displays the error item check box On/Off status. Select this check box to display the selected error notification.
Select Shortcut Icon	The selected icon is displayed on the taskbar. The setting's example is shown on the right window. By clicking the shortcut icon, you can access the Monitoring Preferences dialog box easily.

Note:

Click **Default** to revert all items to the default settings.

Accessing EPSON Status Monitor 3

Do one of the following to access EPSON Status Monitor 3:

- Double-click the printer shortcut icon on the taskbar. To add a shortcut icon to the taskbar, see “Setting up EPSON Status Monitor 3” on page 32.
- Open the Utility menu, and then click the EPSON Status Monitor 3 button. To open the Utility menu, see “Setting up EPSON Status Monitor 3” on page 32.

When you access EPSON Status Monitor 3 as described above, the following printer status window appears.



You can check the printer status in this window.

Note:

*It might not be possible to retrieve the printer status during printing. In this situation, click the **EPSON Status Monitor 3** button in the Utility tab, and use the printer with the status window left open.*

Setting the Auto Tear-Off Function

You can select whether to turn on the auto tear-off function. When the auto tear-off function is turned on, the printer advances the continuous paper to the tear-off position automatically when a set time has passed after printing.

1. Access the printer driver. See “Using the Printer Driver” on page 26.
2. Click the **Utility** tab, and then click the **Auto Tearoff Setting** button.
3. Select **auto tearoff enabled** and select the delay time box, or select **auto tearoff disabled**.
4. Click **OK**.

Setting the Buzzer

Setting whether the buzzer sounds when printing is finished

1. Access the printer driver. See “Using the Printer Driver” on page 26.
2. Click the **Utility** tab, and then click **Other Config**.
3. Select the **Control Buzzer Settings** check box, and then select **Every Page** or **Only Last Page** in the Control Buzzer Settings drop-down list to have the buzzer sound when printing is finished. Clear the **Control Buzzer Settings** check box to have the buzzer not sound.
4. Click **OK**.
5. Click **OK**.

Setting whether the buzzer sounds when an error occurs

1. Access the printer driver. See “Using the Printer Driver” on page 26.
2. Click the **Utility** tab, and then click the **Notification Setting** button.
3. Select **Beep** to have the buzzer sound when an error occurs, or select **No Beep** to have the buzzer not sound.
4. Click **OK**.

Using Reduce Scraping Mode

In Reduce scraping mode, scraping by the print head can be reduced.

1. Access the printer driver. See “Using the Printer Driver” on page 26.
2. Click the **Utility** tab, and then click the **Printer and Option Information** button. The Printer and Option Information dialog box appears.
3. Select the **Reduce scraping** check box.
4. Click **OK**.

Note:

When the printer is in reduce scraping mode, printing speed may be reduced, printed characters may be blurred, and the print quality of barcodes may decline.

Adjusting the Print Position

Follow these steps to adjust the print position horizontally.

1. Access the printer driver. See “Using the Printer Driver” on page 26.
2. Click the **Utility** tab, and then click the **Print Position Adjustment** button.
3. Set an adjustment value for Print Position, and then click **OK**.

Select a value using the slider or enter a value in the box.

To adjust the print position to the left when viewed from the front of the printer, set a positive value. To adjust the print position to the right, set a negative value.

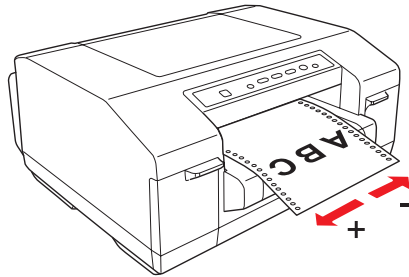

4. Click **OK**.

Note:

Data that is outside the printable area due to the print position adjustment cannot be printed.

USB Replacement Service

USB Replacement Service is software that automatically changes the output port when another printer of the same model is replaced. When a printer connected using a USB interface is replaced with another printer of the same model, this software detects the new printer, rewrites the printer driver properties registered in Windows, and changes the output port automatically. For example, if a USB-connected printer is malfunctioning, this software allows you to simply change the printer and continue printing without having to manually change the settings in the application or operating system.

Note:

Do not use USB Replacement Service in environments with two or more printers of the same model.

Installing USB Replacement Service

Before installing USB Replacement Service, make sure that the printer driver is installed.

Follow these steps to install USB Replacement Service.

1. Turn off the printer.
2. Make sure that Windows is running on your computer.

3. Insert the printer software CD-ROM in the CD-ROM drive.

Note:

- If the language selection dialog box appears, select your language.*
 - If the EPSON Installation Program dialog box does not appear automatically, double-click the **My Computer** icon, right-click the CD-ROM icon, click **OPEN** in the menu that appears, and then double-click **InstallNavi.exe**.*
4. When the license agreement dialog box appears, read the statement, and then click **Next**.
 5. Select your printer.
 6. Select **USB Replacement Service**, and then click **Install**.
 7. When the installation is complete, click **OK**.

Replacing a USB-connected printer

Follow these steps to replace a printer with another printer of the same model.

1. Access the printer driver, click the **Utility** tab, and then write down the current settings for **Auto Tear Off Setting**, **Notification Settings**, and **Print Position Adjustment**. See “Using the Printer Driver” on page 26.
2. Turn off the printer, and then disconnect the USB cable from the printer.
3. Connect the USB cable to the new printer, and then turn on the printer.
4. Access the printer driver, click the **Utility** tab, and then specify the settings that you wrote down in step 1.
5. Confirm that the top-of-form position is adjusted correctly vertically, and then adjust it with the Micro Adjust function if necessary. See “Adjusting the top-of-form position” on page 24.

BI Parallel Port Driver

BI Parallel Port Driver is software used when communicating at high speed if the printer is connected using a parallel port. The transmission rate quickens when communicating at high speed.

This software is installed automatically when the printer driver is installed.

Specify the following settings to communicate at high speed.

1. For Windows 8 or Server 2012:

Click **Desktop** on the Start screen, move the cursor to the top-right corner of the screen, click **Settings**, and then click **Control Panel**. Next, click **View devices and printers** from the **Hardware and Sound** category.

For Windows 7 or Server 2008 R2:

Click **Start**, and then click **Devices and Printers**.

For Windows Vista or Server 2008:

Click **Start**, click **Control Panel**, click **Hardware and Sound**, and then click **Printers**.

For Windows XP Professional or Server 2003:

Click **Start**, and then click **Printers and Faxes**.

2. Right-click the icon for the printer you want to change the settings for, and then click **Printer properties** (Windows 8, 7, Server 2012, or Server 2008 R2) or **Properties** (Windows Vista, XP, Server 2008, or Server 2003).
3. Click the **Ports** tab.
4. Select the **BILPTx** check box.

The parallel port name is **BILPTx**.

5. Change the BIOS setting on your computer to ECP mode.

For more information about this setting, see the manual for your computer.

EpsonNet Config

EpsonNet Config is software that allows the network administrator to detect printers on the network, and then setup or change functions for the network printers individually or as a batch.

- You can make settings or changes for individual network printers or all network printers as a batch.

- ❑ You can output configuration information for the network printer as a SYLK format file. Because the SYLK format is supported by Microsoft Excel, the user can make batch settings or changes to the configuration information for multiple printers.
- ❑ Previous configuration information is stored as a log, and the file can be output or changed. By performing a batch import of the file, you can restore the settings for individual or multiple network printers.
- ❑ The administrator can set a password to protect the network printer's configurations.
- ❑ You can simplify printer management by registering the printer to My Device.
- ❑ As well as printers on the local network, you can also make settings or changes to printers on an external network (you need to change Search Parameters).

Installing EpsonNet Config

Follow these steps to install EpsonNet Config.

1. Turn off the printer.
2. Make sure that Windows is running on your computer.
3. Insert the printer software CD-ROM in the CD-ROM drive.

Note:

- ❑ *If the language selection dialog box appears, select your language.*
 - ❑ *If the EPSON Installation Program dialog box does not appear automatically, double-click the **My Computer** icon, right-click the CD-ROM icon, click **OPEN** in the menu that appears, and then double-click **InstallNavi.exe**.*
4. When the license agreement dialog box appears, read the statement, and then click **Next**.
 5. Select your printer.
 6. Select **EpsonNet Config**, and then click **Install**.
 7. When the installation is complete, click **OK**.

EPSON Printer Setting

EPSON Printer Setting allows you to change the printer's default settings.

This tool is included in the printer software CD-ROM. Start the tool from the printer software CD-ROM. To change the settings, see the online help for EPSON Printer Setting.

Setting Up Your Printer on a Network

Sharing the printer

This section describes how to share the printer on a standard Windows network.

The computers on a network can share a printer that is directly connected to one of them. The computer that is directly connected to the printer is the printer server, and the other computers are the clients which need permission to share the printer with the printer server. The clients share the printer through the printer server.

According to the versions of Windows and your access rights on the network, perform the appropriate settings for the printer server and clients.

Setting the printer server

See “Setting up your printer as a shared printer” on page 42.

Setting the clients

See “Setting the clients” on page 45.

Note:

- When connecting to a Windows XP shared printer, error and warning notifications do not appear during printing. Installing Windows XP Service Pack 1 or later will solve this problem.*
- When connecting to a shared printer beyond a router, error and warning notification for shared printers during printing is not available in some cases because of the router's settings.*
- The printer server and clients should be set on the same network system, and they should be under the same network management before making the settings.*

- ❑ *The screen shots that are shown on the following pages may differ depending on the version of Windows that you are using.*

Setting up your printer as a shared printer

Note:

You must log on to the printer server computer as the administrator.

1. For Windows 8 or Server 2012:
Click **Desktop** on the Start screen, move the cursor to the top-right corner of the screen, click **Settings**, and then click **Control Panel**. Next, click **View devices and printers** from the **Hardware and Sound** category.

For Windows 7 or Server 2008 R2:

Click **Start**, and then click **Devices and Printers**.

For Windows Vista or Server 2008:

Click **Start**, click **Control Panel**, click **Hardware and Sound**, and then click **Printers**.

For Windows XP Professional or Server 2003:

Click **Start**, and then click **Printers and Faxes**.

2. For Windows 8, 7, Server 2012, or Server 2008 R2:
Right-click your printer icon, click **Printer properties**, and then click the **Sharing** tab in the dialog box that appears.

For Windows Vista, XP, Server 2008, or Server 2003:

Right-click your printer icon, and then click **Sharing** in the menu that appears.

For Windows XP:

If the following menu appears, click either **Network Setup Wizard** or **If you understand the security risks but want to share printers without running the wizard, click here**.

In either case, follow the on-screen instructions.

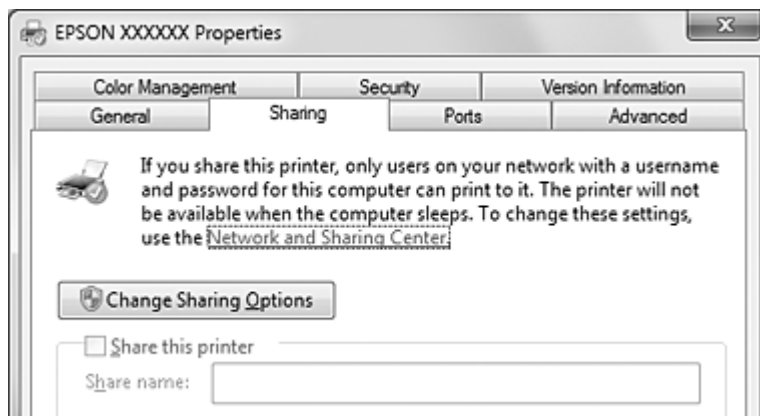

- For Windows 8, 7, Vista, XP, Server 2012, Server 2008 R2, Server 2008, or Server 2003: Select **Share this printer**, and then type the name in the Share name box and click **OK**.

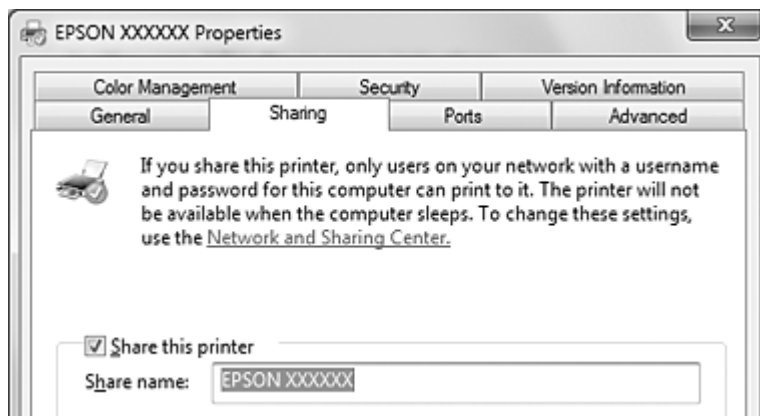

Note:

- ❑ Do not use spaces or hyphens for the shared printer name. Otherwise, an error may occur.
- ❑ For Windows 8, 7, Vista, Server 2012, Server 2008 R2, or Server 2008 you cannot select **Share this printer** until you click **Change sharing options**.

You need to set the client computers so that they can use the printer on a network. For more information, see “Setting the clients” on page 45.

Sharing the printer when the firewall is on

Note:

To share files and printers when the Windows firewall is on, perform the following procedure.

Windows 8 or Server 2012

1. Click **Desktop** on the Start screen, move the cursor to the top-right corner of the screen, click **Settings**, and then click **Control Panel**. Next, click **System and Security**, and then click **Windows Firewall**.
2. Click **Turn Windows Firewall on or off** in the window on the left. Make sure that **Block all incoming connections, including those in the list of allowed apps** is not selected, and then click **OK**.
3. Click **Allow an app or feature through Windows Firewall** in the window on the left.
4. Select **File and Printer Sharing**, and then click **OK**.

Windows 7 or Server 2008 R2

1. Click **Start**, click **Control Panel**, click **System and Security**, and then click **Windows Firewall**.
2. Click **Turn Windows Firewall on or off** in the window on the left. Make sure that **Block all incoming connections, including those in the list of allowed programs** is not selected, and then click **OK**.
3. Click **Allow a program or feature through Windows Firewall** in the window on the left.
4. Select **Share file and printer**, and then click **OK**.

Windows Vista or Server 2008

1. Click **Start**, and then click **Control Panel**.
2. Click **Security**, and then click **Windows Firewall** to open the **Windows Firewall** dialog box.
3. Click **Turn Windows Firewall on or off** in the window on the left. When the **User Account Control** dialog box is displayed, click **Continue**.
4. Make sure that **Block all incoming connections** is not selected in the **General** tab.

5. Click the **Exceptions** tab, select **File and Printer Sharing**, and then click **OK**.

Windows XP or Server 2003

1. Click **Start**, and then click **Control Panel**.
2. Click **Security Center**.
3. Click **Windows Firewall** to open the **Windows Firewall** dialog box.
4. Make sure that **Don't allow exceptions** is not selected in the **General** tab.
5. Click the **Exceptions** tab, select **File and Printer Sharing**, and then click **OK**.

Setting the clients

This section describes how to install the printer driver by accessing the shared printer on a network.

Note:

- To share the printer on a Windows network, you need to set the printer server. For more information, see "Setting up your printer as a shared printer" on page 42.*
 - This section describes how to access the shared printer on a standard network system using the server (Microsoft workgroup). If you cannot access the shared printer due to the network system, ask the administrator of the network for assistance.*
 - If the printer drivers are not already installed on the client, please install them before performing these settings.*
1. For Windows 8 or Server 2012:
Click **Desktop** on the Start screen, move the cursor to the top-right corner of the screen, click **Settings**, and then click **Control Panel**. Next, click **View devices and printers** from the **Hardware and Sound** category.

For Windows 7 or Server 2008 R2:

Click **Start**, and then click **Devices and Printers**.

For Windows Vista or Server 2008:

Click **Start**, click **Control Panel**, click **Hardware and Sound**, and then click **Printers**.

For Windows XP Professional or Server 2003:

Click **Start**, and then click **Printers and Faxes**.

2. Right-click the icon for the printer you want to change the settings for, and then click **Printer properties** (Windows 8, 7, Server 2012, or Server 2008 R2) or **Properties** (Windows Vista, XP, Server 2008, or Server 2003).
3. Click the **Ports** tab, and then click **Add Port**.

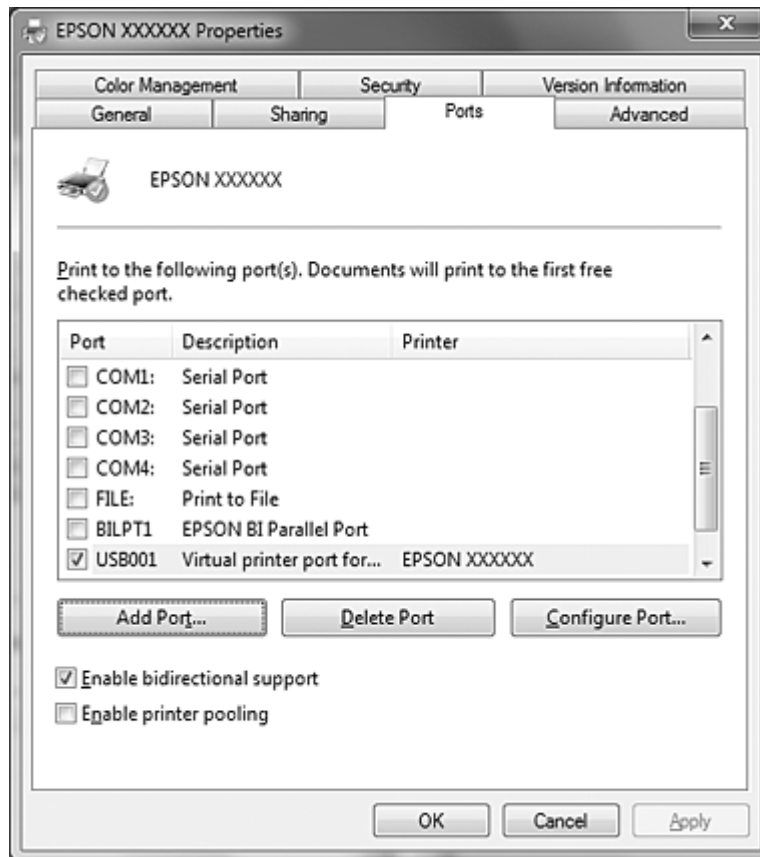

4. When the **Printer Ports** dialog box appears, select **Local Port**, and then click **New Port**.

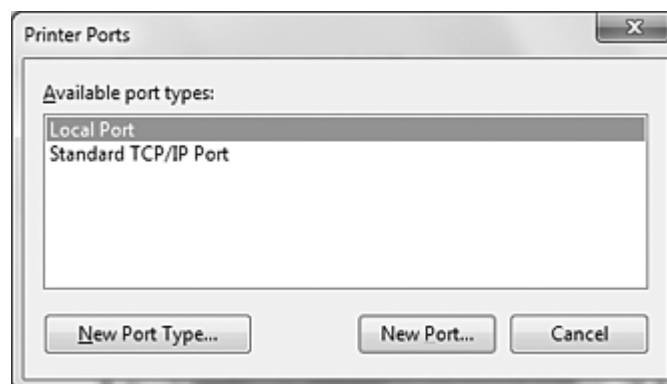

5. Enter the following information for the port name, and then click **OK**.

\\Name of computer connected to the target printer\name of shared printer

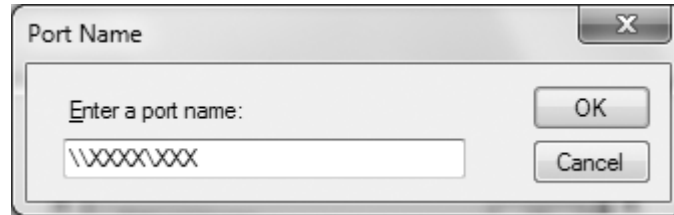

6. After returning to the **Printer Ports** dialog box, click **Close**.
7. Check that the name you entered for the port has been added and selected, and then click **Close**.

Canceling Printing

If the printouts are not what you expected and contain incorrect or garbled characters or images, you may need to cancel printing. Follow the instructions below to cancel printing.

Using the printer button

Press the **Pause** button, and then press the **Job Cancel** button for three seconds to cancel a print job in progress.

Using Windows

Double-click the printer shortcut icon on the taskbar.



When canceling all printing documents, select **Cancel All Documents** on the Printer menu.



When canceling a specific document, select the document you want to cancel, and then select **Cancel** on the Document menu.

The print job is canceled.

Uninstalling the Printer Software

When you want to reinstall or upgrade the printer driver, uninstall the printer driver that is currently installed.

Uninstalling the printer driver and utilities

1. Quit all applications.
2. For Windows 8 or Server 2012:
Click **Desktop** on the Start screen, move the cursor to the top-right corner of the screen, click **Settings**, and then click **Control Panel**.

For Windows 7, Vista, XP, Server 2008 R2, Server 2008, or Server 2003:
Click **Start**, and then click **Control Panel**.

3. Click **Uninstall a program** (Windows 8, 7, Vista, Server 2012, Server 2008 R2, or Server 2008) or click the **Add or Remove Programs** icon (Windows XP or Server 2003).

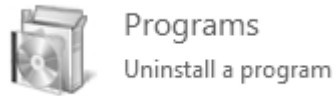

4. Select the **EPSON Printer Software**, and then click **Uninstall/Change** (Windows 8, 7, Vista, Server 2012, Server 2008 R2, or Server 2008) or **Change/Remove** (Windows XP or Server 2003).

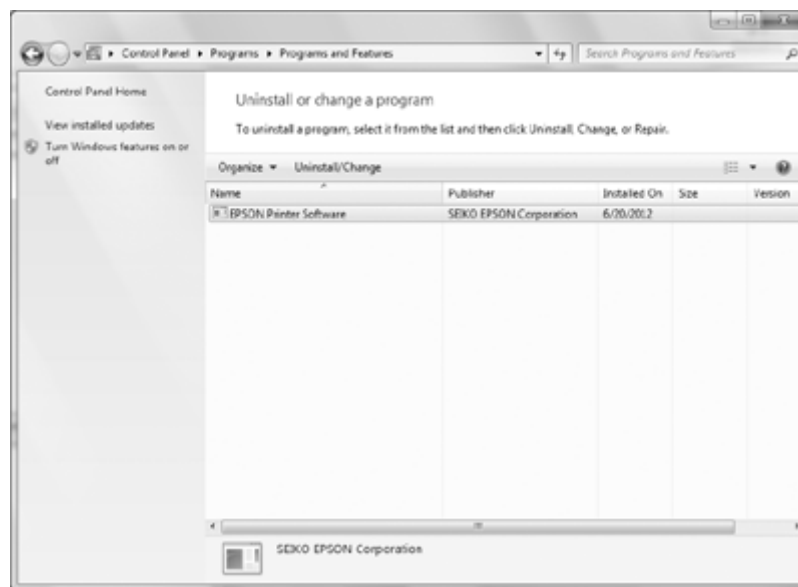

5. Click the **Printer Model** tab, select the icon of the printer you want to uninstall, and then click **OK**.

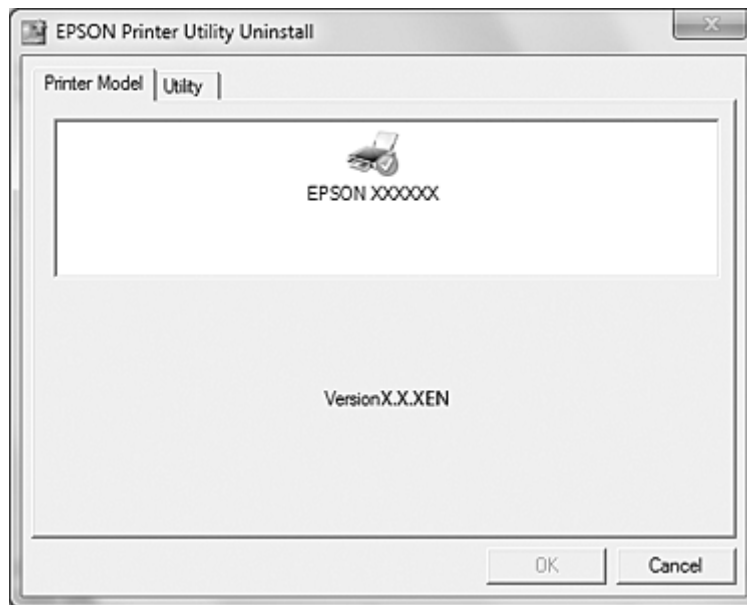

Note:

- EPSON Status Monitor 3 is uninstalled with the printer driver. EPSON Status Monitor 3 cannot be uninstalled separately.*
 - USB Replacement Service and BI Parallel Port Driver can be uninstalled separately. To uninstall only USB Replacement Service or BI Parallel Port Driver, make sure that nothing is selected in the **Printer Model** tab. Then, click the **Utility** tab, select **USB Replacement Service** or **BI Parallel Port Driver**, and click **OK**.*
6. Follow the on-screen instructions.

Chapter 5

Control Panel

Using the Control Panel

You can control simple printer operations—such as advancing paper to the tear-off position, form feeding, loading and ejecting paper, cleaning the print head, and canceling print jobs—with the buttons on the control panel. The control panel lights show the printer's status.

Control panel buttons and lights

Note:

The lights may flash when an error has occurred. For more information, see “Using the Error Indicators” on page 55.

For Chinese users

GP-C832

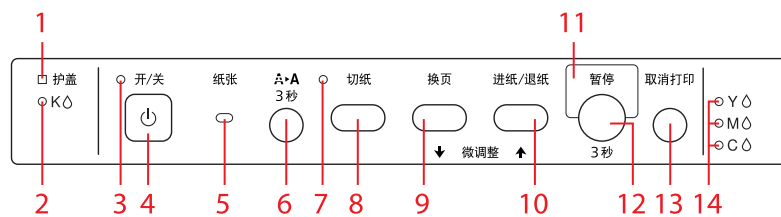

GP-M832

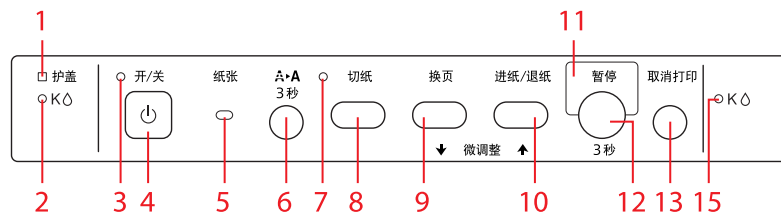

For Taiwanese users

GP-C830

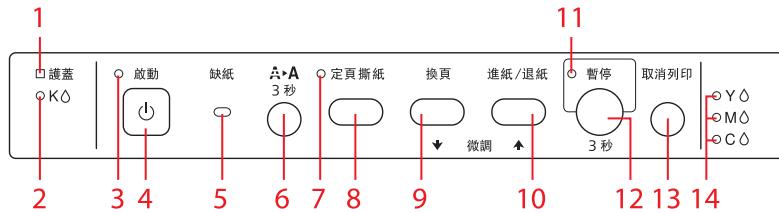

GP-M830

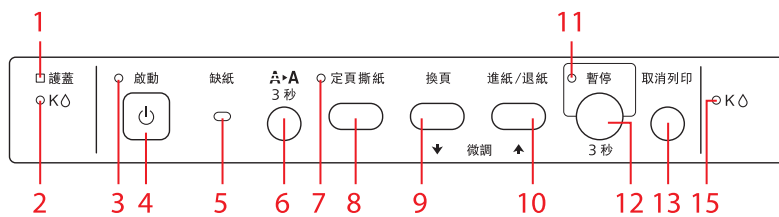

For other users

GP-C830/GP-C831

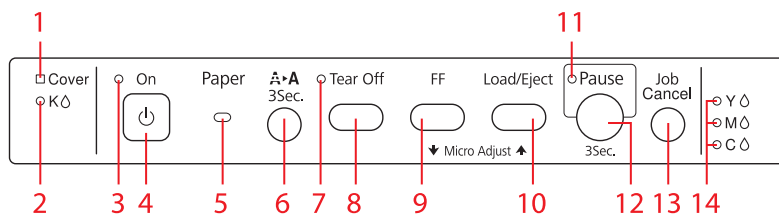

GP-M830/GP-M831

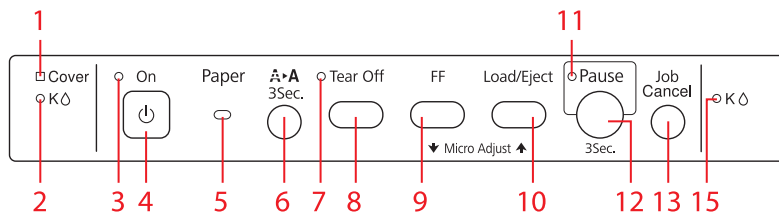

1. Cover light

On when the right/left ink cartridge cover or top cover is open.

2. Left ink light (**K**)

- Flashes when ink is low.
- On when an ink cartridge has reached its replacement time or when the left ink cartridge cover is closed with an ink cartridge not installed.

3. **On** light

- On when the printer is turned on.
- Flashes when receiving data and during print head cleaning.
- Flashes rapidly until the printer is turned off using the **On** button.

4. **On** button

- Turns the printer on.
- Turns the printer off when pressed for three seconds.

5. **Paper** light

- On when no paper is loaded or when paper is not loaded correctly.
- Flashes when the paper failed to eject or a paper jam has occurred.

6. **Cleaning** button

Cleans the print head when pressed for three seconds.

7. **Tear Off** light

On when continuous paper is in the tear-off position.

8. **Tear Off** button

- Advances continuous paper to the tear-off position.
- Feeds continuous paper backward from the tear-off position to the top-of-form position.

9. **FF** button

Inserts a page break.

10. **Load/Eject** button

- Loads continuous paper from the standby position.
- Feeds continuous paper backward to the standby position.

11. Pause light

- On when the printer is paused.
- Flashes when the printer is in Micro Adjust mode.

12. Pause button

Stops printing temporarily, and resumes printing when pressed again. When pressed for three seconds or more, the printer enters Micro Adjust mode*. The printer exits the mode when pressed again.

13. Job Cancel button



Cancels the print job when pressed for three seconds or more when the printer is paused.

14. Right ink light (Y, M, C) (GP-C830/GP-C831/GP-C832)

- Flashes when ink is low.
- On when an ink cartridge has reached its replacement time or when the right ink cartridge cover is closed with an ink cartridge not installed.

15. Right ink light (K) (GP-M830/GP-M831/GP-M832)

- Flashes when ink is low.
- On when an ink cartridge has reached its replacement time or when the right ink cartridge cover is closed with an ink cartridge not installed.

* Micro Adjust mode: When you hold down the **Pause** button for three seconds, the printer enters Micro Adjust mode. In this mode, you can press the **FF**  and **Load/Eject**  buttons to adjust the top-of-form or tear-off position. For more information, see “Adjusting the top-of-form position” on page 24.

Chapter 6

Troubleshooting

Using the Error Indicators

You can identify many common printer problems using the lights on the control panel. If your printer stops working and one or more control panel lights are on or flashing or the printer beeps, use the following table to diagnose and fix the problem. If you cannot fix your problem using this table, see “Problems and Solutions” on page 57.

Panel light state	Beep pattern	Problem
		Solution
<input type="radio"/> On <input type="radio"/> Paper	●	No paper is attached to the tractor unit or the paper is used up during printing.
		Attach the paper to the tractor, and then press the Load/Eject button.
<input type="radio"/> On <input type="radio"/> Paper	●	The paper is not fully loaded.
		Remove the paper if there is a paper jam. Then, reattach the paper to the tractor and press the Load/Eject button.
		The paper is not ejected completely.
		<p>If the paper is advanced too far and ejection failed, press the Load/Eject button again to feed the paper backward. However, to prevent a paper jam, do not feed the paper backward 558.8 mm (22 inches) or more.</p> <p>If the length of the paper that you want to eject is longer than about 550 mm (22 inches), tear off the paper, and then press the Load/Eject button.</p>
<input type="radio"/> On <input type="radio"/> Cover	-	The top cover or ink cartridge cover is open.
		Close the covers.

Panel light state	Beep pattern	Problem
		Solution
○ On ○ K▲* ○ Y▲* ○ M▲* ○ C▲*	●	The ink cartridge has reached its replacement time.
		Replace the ink cartridge. For more information, see "Replacing an ink cartridge" on page 75.
○ On ○ K▲* ○ Y▲* ○ M▲* ○ C▲*	●	The ink cartridge is not installed.
		Install the ink cartridge. For more information, see "Replacing an ink cartridge" on page 75.
○ On ○◌ K▲ ○◌ Y▲* ○◌ M▲* ○◌ C▲*	-	Ink is low.
		Obtain a replacement ink cartridge.
○◌ On ○◌ Cover ○◌ K▲, ○◌ Y▲, ○◌ M▲, ○◌ C▲ ** ○◌ K▲, ○◌ K▲***	●●●●●	A product maintenance error has occurred.
		Contact a qualified service person.
○◌ On ○◌ Cover ○◌ Paper ○◌ Tear Off ○◌ Pause	●●●●●	A fatal error has occurred.
		Turn off the printer and check for a paper jam. If there is a paper jam, remove the jammed paper, and then turn on the printer. If the scale is dirty, clean it with a soft cloth. See "Cleaning the Printer" on page 103. If the problem persists, turn off the printer, wait several minutes, and then turn it on again.

* The status of the right black ink light is shown for the GP-M830/GP-M831/GP-M832.

** All of the ink lights flash at the same time (GP-C830/GP-C831/GP-C832).

*** Both of the ink lights flash at the same time (GP-M830/GP-M831/GP-M832).

○ = on, ○◌ = flashing

● = Ten long beeps

●●●●● = Five sets of five short beeps (twenty-five beeps)

Note:

The printer beeps once when the printer enters or exits Micro Adjust mode. In Micro Adjust mode, the printer also beeps once when the printer reaches the default top-of-form and tear-off positions. When the printer reaches the minimum and maximum adjustment limits, the printer beeps twice.

Problems and Solutions

Most problems you may encounter while operating your printer have simple solutions.

Power supply

Power is not being supplied

The lights on the control panel do not go on.	
Cause	What to do
The power cord may be unplugged.	Check that the power cord is properly plugged into the electrical outlet.
The outlet may not be operating.	If the electrical outlet is controlled by an outside switch or automatic timer, use a different outlet. Plug another electrical device, such as a lamp, into the outlet to determine whether the outlet is operating properly.

Printing

Printing or printout quality problems

The Pause light is off, but nothing is printed.	
Cause	What to do
The software may not be installed properly.	Check that the software is installed properly for your printer, as described in the <i>Start Here</i> . Check the software's printer settings.
The interface cable may not match the specifications of the printer or computer.	Check both ends of the interface cable. Make sure the cable meets both the printer and computer specifications.

The printer port may not be set correctly.	<p>For Windows 8 or Server 2012: Click Desktop on the Start screen, move the cursor to the top-right corner of the screen, click Settings, and then click Control Panel. Next, click View devices and printers from the Hardware and Sound category.</p> <p>For Windows 7 or Server 2008 R2: Click Start, and then click Devices and Printers.</p> <p>For Windows Vista, XP, Server 2008, or Server 2003: Click Start, click Control Panel, and then click Printers and Faxes.</p> <p>When the icon of the printer you are using appears, right-click it and select Printer properties (Windows 8, 7, Server 2012, or Server 2008 R2) or Properties (Windows Vista, XP, Server 2008, or Server 2003). Then, click the Ports or Details tab and select the appropriate port.</p>
The Paper light is on and the printer beeps ten times.	
Cause	What to do
The printer may be out of paper.	Load paper in the printer.
The printer makes a strange noise, the beeper sounds ten times, and the printer stops abruptly.	
Cause	What to do
Paper may be jammed.	Turn off the printer and check for a paper jam. If there is a paper jam, remove the jammed paper, and then turn on the printer. If the problem persists, turn off the printer, wait several minutes, and then turn it on again.
The beeper sounds five sets of five short beeps (twenty-five times) and all the lights except the ink lights flash.	
Cause	What to do
A fatal error has occurred.	Turn off the printer and turn it on again. If the problem persists, check for a paper jam. If there is no jam, contact your dealer or a qualified service person.
Print quality declines.	
Cause	What to do
The print head nozzles are clogged.	Run the Head Cleaning utility to clear any clogged ink nozzles. For more information, see "Cleaning the Print Head" on page 99.
Ink cartridges not manufactured by Epson are used.	Use genuine Epson ink cartridges.

Medicine bags may become dirty when printing in an environment with high humidity if the surface of the medicine bags is a polyvinyl resin.	Print in an environment with humidity of 65% or less.
The printout may become blurry depending on the media type.	Adjust the print density for the media type to prevent the printout from becoming blurry. For more information, see "Printer settings" on page 30.
Misaligned vertical lines appear.	
Cause	What to do
The gaps in the print head are misaligned.	Run the Print Head Alignment utility. For more information, see "Aligning the Print Head" on page 101.
The printing speed is slow when connecting using the parallel port.	
Cause	What to do
The parallel interface is not set for high-speed communication.	Use BI Parallel Port Driver, which is installed with the printer driver, to communicate at high speed. For more information, see "BI Parallel Port Driver" on page 38.

Printed characters are not what you expected

The timesteps or characters you sent with your software did not print.	
Cause	What to do
The software may not be properly configured.	Check that the software is correctly configured for your printer.

Printing position problems

Printing starts too high or too low on the page, or the bottom part of one page is printed at the top of the next page.	
Cause	What to do
The top margin or top-of-form position settings are incorrect.	<p>Check and adjust the margin or top-of-form position settings in your application. For more information, see "Printable area" on page 92.</p> <p>You can also adjust the top-of-form position using the Micro Adjust function. However, settings made in Windows applications override settings made in Micro Adjust mode. For more information, see "Adjusting the top-of-form position" on page 24.</p>
Printing starts too far to the right or left on the page.	

Cause	What to do
The left or right margin settings are incorrect.	Check and adjust the margin settings in your application. For more information, see "Printable area" on page 92. If the settings cannot be changed in your application, adjust the print position horizontally in the printer driver. For more information, see "Adjusting the Print Position" on page 36.
Page length does not match the length of the paper.	
Cause	What to do
The page length setting in your application may be incorrect.	Check the page length setting in your application and adjust it if necessary.

Paper handling

Paper loading or feeding problems

The tractor does not feed the paper.	
Cause	What to do
The paper may have come off the tractor.	Reattach the paper to the tractor.
The paper supply is obstructed.	Make sure the paper supply is not obstructed by a cable or some other object.
The tear-off position is not aligned correctly.	
Cause	What to do
The tear-off position setting is incorrect.	Adjust the tear-off position using the Micro Adjust function. For more information, see "Adjusting the tear-off position" on page 23.
Paper feeding is crooked or the paper jams.	
Cause	What to do
The paper supply is too far away from the printer.	Make sure that your paper supply is within 1 meter (3 feet) of the printer.
The holes on the sides of the paper are misaligned.	Check that the holes on the sides of the paper are aligned with each other. Also, make sure the sprocket units are locked and their covers are closed.

Your paper may be the wrong size or thickness for the printer.	Make sure that the paper size and thickness are within the specified ranges. For information on the continuous paper specifications, see "Paper" on page 89.
The paper may jam depending on your operating environment.	To prevent a paper jam, select Silent Feed mode with the printer driver. See "Printer settings" on page 30.
The paper does not eject properly.	
Cause	What to do
The page may be too long or too short.	Tear off the supply of paper and eject the page from the printer. Use only paper that is within the specified length range described under "Paper" on page 89.

Network problems

A communication error has occurred.	
Cause	What to do
Multiple users are logged on to a single computer at the same time.	On a Windows 8/7/Vista/XP system with multiple users, a communication error may occur when switching to a new user and starting a new print job while the print job for the previous user is still printing. Make sure that the print job for the first user is complete and the user is logged off before switching to a new user and starting a new print job.

Other problems

The color inks are consumed even when printing black and white documents (GP-C830/GP-C831/GP-C832 only).	
Cause	What to do
Not only the black ink, but also the color inks are consumed during the following operations: print head cleaning and self-cleaning.	-

Correcting USB Problems

If you are having difficulty using your printer with a USB connection, read the information in this section.

Make sure that your computer is a Windows 8, 7, Vista, XP, or 2000 pre-installed model

Your computer must be a Windows 8, 7, Vista, XP, or 2000 pre-installed model. You may not be able to install or run the USB printer driver on a computer which is not equipped with a USB port or which has been upgraded from Windows 95 to Windows XP, Me, 98, or 2000.

For details about your computer, contact your dealer.

Printer does not work correctly with the USB cable

If your printer does not work correctly with the USB cable, try one or more of these solutions:

- Make sure that the cable you are using is a standard, shielded USB cable.
- If you are using a USB hub, connect the printer to the first tier of the hub, or connect the printer directly to the computer's USB port.

Clearing Paper Jams

Follow these steps to clear a paper jam.



Caution:

Pull out the jammed paper gently. If you remove the jammed paper with force, torn pieces may stay inside the printer or the printer may be damaged.

When the printer detects an error and stops printing:

1. Tear off the printed part of the paper.
2. Open the sprocket covers of both sprockets.
3. Remove the paper. Pull the continuous paper forward or backward out of the printer.

Note:

Pull paper straight out to remove it from the printer.

4. Open the top cover and make sure there is no paper left.

5. Attach the continuous paper to the tractor unit. See “Printing on Continuous Paper” on page 15.
6. Turn off the printer, and then turn on the printer.
7. Determine which pages were not printed correctly and print them again.

When the user finds a paper jam before the printer detects an error:

1. Press the **Pause** button to stop printing.
2. Hold down the **Tear Off** and **FF** buttons for about three seconds. The jammed paper is released.
3. Tear off the printed part of the paper.
4. Open the sprocket covers of both sprockets.
5. Remove the paper. Pull the continuous paper forward or backward out of the printer.

Note:

Pull paper straight out to remove it from the printer.

6. Open the top cover and make sure there is no paper left.
7. Attach the continuous paper to the tractor unit. See “Printing on Continuous Paper” on page 15.
8. Press the **Job Cancel** button to cancel printing.
9. Press the **Pause** button again to restart printing.
10. Determine which pages were not printed and print them again.

Chapter 7

Where To Get Help

Technical Support Web Site

Epson's Technical Support Web Site provides help with problems that cannot be solved using the troubleshooting information in your product documentation. If you have a Web browser and can connect to the Internet, access the site at:

<http://support.epson.net/>

If you need the latest drivers, FAQ's, manuals, or other downloadables, access the site at:

<http://www.epson.com>

Then, select the support section of your local Epson Web site.

Contacting Customer Support

Before Contacting Epson

If your Epson product is not operating properly and you cannot solve the problem using the troubleshooting information in your product documentation, contact customer support services for assistance. If customer support for your area is not listed below, contact the dealer where you purchased your product.

Customer support will be able to help you much more quickly if you give them the following information:

- Product serial number
(The serial number label is usually on the back of the product.)
- Product model
- Product software version
(Click **About**, **Version Info**, or similar button in the product software.)
- Brand and model of your computer

- ❑ Your computer operating system name and version
- ❑ Names and versions of the software applications you normally use with your product

Help for Users in Australia

Epson Australia wishes to provide you with a high level of customer service. In addition to your product documentation, we provide the following sources for obtaining information:

Your Dealer

Don't forget that your dealer can often help identify and resolve problems. The dealer should always be the first call for advise on problems; they can often solve problems quickly and easily as well as give advise on the next step to take.

Internet URL <http://www.epson.com.au>

Access the Epson Australia World Wide Web pages. Worth taking your modem here for the occasional surf! The site provides a download area for drivers, Epson contact points, new product information and technical support (e-mail).

Epson Helpdesk

Epson Helpdesk is provided as a final backup to make sure our clients have access to advise. Operators on the Helpdesk can aid you in installing, configuring and operating your Epson product. Our Pre-sales Helpdesk staff can provide literature on new Epson products and advise where the nearest dealer or service agent is located. Many types of queries are answered here.

The Helpdesk numbers are:

Phone: 1300 361 054

Fax: (02) 8899 3789

We encourage you to have all the relevant information on hand when you ring. The more information you prepare, the faster we can help solve the problem. This information includes your Epson product documentation, type of computer, operating system, application programs, and any information you feel is required.

Help for Users in Singapore

Sources of information, support, and services available from Epson Singapore are:

World Wide Web (<http://www.epson.com.sg>)

Information on product specifications, drivers for download, Frequently Asked Questions (FAQ), Sales Enquiries, and Technical Support via e-mail are available.

Help for Users in Thailand

Contact for information, support, and services are:

World Wide Web (<http://www.epson.co.th>)

Information on product specifications, drivers for download, Frequently Asked Questions (FAQ), and e-mail are available.

Help for Users in Indonesia

Contacts for information, support, and services are:

World Wide Web (<http://www.epson.co.id>)

- Information on product specifications, drivers for download
- Frequently Asked Questions (FAQ), Sales Enquiries, questions through e-mail

Help for Users in Hong Kong

To obtain technical support as well as other after-sales services, users are welcome to contact Epson Hong Kong Limited.

Internet Home Page

Epson Hong Kong has established a local home page in both Chinese and English on the Internet to provide users with the following information:

- Product information

- ❑ Answers to Frequently Asked Questions (FAQs)
- ❑ Latest versions of Epson product drivers

Users can access our World Wide Web home page at:

<http://www.epson.com.hk>

Help for Users in Malaysia

Contacts for information, support, and services are:

World Wide Web (<http://www.epson.com.my>)

- ❑ Information on product specifications, drivers for download
- ❑ Frequently Asked Questions (FAQ), Sales Enquiries, questions through e-mail

Help for Users in India

Contacts for information, support, and services are:

World Wide Web (<http://www.epson.co.in>)

Information on product specifications, drivers for download, and products enquiry are available.

Help for Users in the Philippines

To obtain technical support as well as other after sales services, users are welcome to contact the Epson Philippines Corporation.

World Wide Web (<http://www.epson.com.ph>)

Information on product specifications, drivers for download, Frequently Asked Questions (FAQ), and E-mail Enquiries are available.

Help for Users in Europe

Check your **Pan-European Warranty Document** for information on how to contact Epson Customer support.

Help for Users in North America

Epson provides the technical support services listed below.

Internet Support

Visit Epson's support website for your printer (U.S. or Canada) for solutions to common problems. You can download drivers and documentation, get FAQs and troubleshooting advice, or e-mail Epson with your questions.

Speak to a Support Representative

Before you call Epson for support, please have the following information ready:

- Product name
- Product serial number (located on the back of product)
- Proof of purchase (such as a store receipt) and date of purchase
- Computer configuration
- Description of the problem

Then call:

- U.S.: (562) 290-4322, 6 am to 8 pm, Pacific Time, Monday through Friday, and 7 am to 4 pm, Saturday.
- Canada: (905) 709-2567, 6 am to 6 pm, Pacific Time, Monday through Friday.

Days and hours of support are subject to change without notice. Toll or long distance charges may apply.

Purchase Supplies and Accessories

You can purchase Epson ribbons at <http://www.epson.com> (U.S. sales) or <http://www.epson.ca> (Canadian sales). You can also purchase supplies from an Epson authorized reseller. To find the nearest one, call 800-GO-EPSON (800-463-7766).

Help for Users in Latin America

Epson provides the technical support services listed below.

Internet Support

Visit Epson's support web site for your printer for solutions to common problems. You can download drivers and documentation, get FAQs and troubleshooting advice, or e-mail Epson with your questions.

Speak to a Support Representative

Before you call Epson for support, please have the following information ready:

- Product name
- Product serial number (located on the back of product)
- Proof of purchase (such as a store receipt) and date of purchase
- Computer configuration
- Description of the problem

Then call:

Country	Telephone
Argentina	(54 11) 5167-0300
Brazil	0800-880-0094
Bolivia*	800-100-116
Chile	(56 2) 484-3400
Colombia	(57 1) 523-5000
Costa Rica	800-377-6627

Country		Telephone
Dominican Republic*		1-888-760-0068
Ecuador*		1-800-000-044
El Salvador*		800-6570
Guatemala*		1-800-835-0358
Honduras**		800-0122 Code: 8320
Mexico	Mexico City	(52 55) 1323-2052
	Other cities	01-800-087-1080
Nicaragua*		00-1-800-226-3068
Panama*		00-800-052-1376
Peru	Lima	(51 1) 418-0210
	Other cities	0800-10126
Uruguay		00040-5210067
Venezuela		(58 212) 240-1111

* Contact your local phone company to call this toll free number from a mobile phone.

** Dial first 7 digits, wait for a message, then enter code.

If your country is not on the list, please contact your nearest Epson office. May be subject to additional local or long distance calling costs.

Purchase supplies and accessories

You may purchase Epson original ribbons at an authorized Epson reseller. To find your nearest reseller, please contact Epson as described above.

Chapter 8

Consumables

Replacing the Ink Cartridges

Genuine Epson ink cartridges

When replacement of any of the ink cartridges is required, you cannot print. Genuine Epson ink cartridges are designed and manufactured to work properly with your Epson printer. They ensure proper operation and long life of the print head and other printer parts. Other products not manufactured by Epson may cause damage to your printer, which is not covered by Epson's warranties.

Your printer uses the following ink cartridges:

	GP-C830	GP-M830	GP-C831	GP-M831	GP-C832	GP-M832
Black	GJIC4(K) S020559	GJIC4(K) S020559	GJIC5(K) S020563	GJIC5(K) S020563	GJIC6(K) S020567	GJIC6(K) S020567
Cyan	GJIC4(C) S020560	-	GJIC5(C) S020564	-	GJIC6(C) S020568	-
Magenta	GJIC4(M) S020561	-	GJIC5(M) S020565	-	GJIC6(M) S020569	-
Yellow	GJIC4(Y) S020562	-	GJIC5(Y) S020566	-	GJIC6(Y) S020570	-

Checking the ink cartridge status

To check the ink cartridge status, do one of the following:

- Double-click the printer shortcut icon on the taskbar. To add a shortcut icon to the taskbar, see "Setting up EPSON Status Monitor 3" on page 32.

- ❑ Open the printer driver, click the **Utility** tab, and then click the **EPSON Status Monitor 3** button.

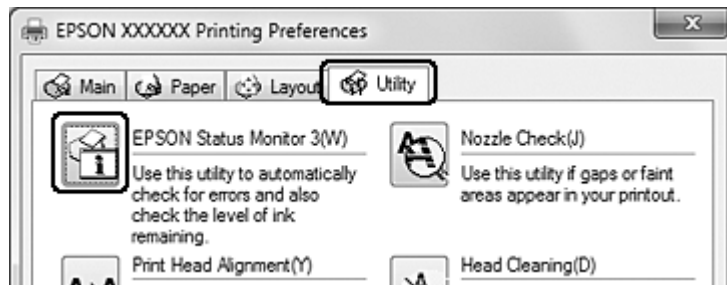

A graphic displays the ink cartridge status.

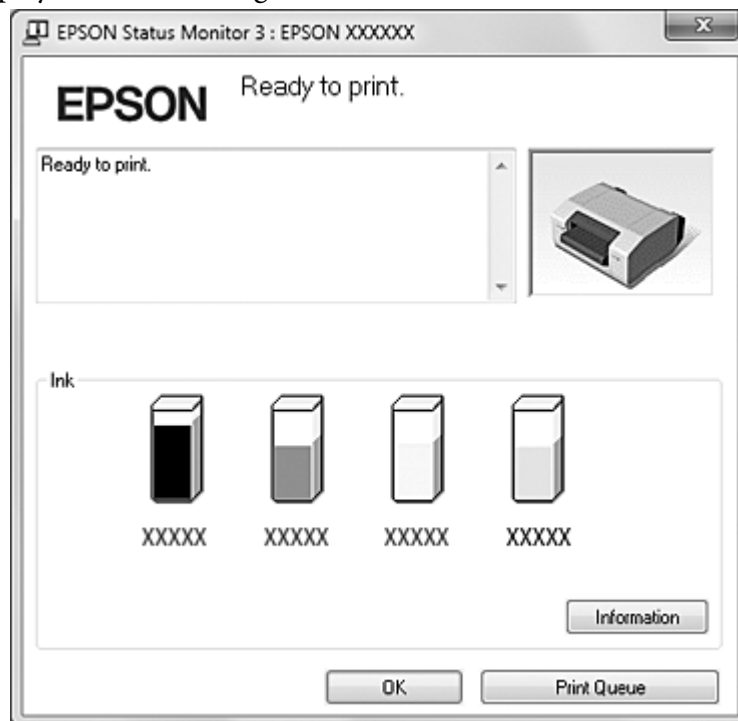

Note:

If any of the ink cartridges installed in the printer is broken, incompatible with the printer model, or improperly installed, EPSON Status Monitor 3 will not accurately display the ink cartridge status. Be sure to replace or reinstall any ink cartridge as indicated by EPSON Status Monitor 3.

- ❑ The progress meter appears automatically when you start a print job.



Note:

To display the progress meter automatically, click the **Utility** tab in the printer driver dialog box, click **Other Config**, and then select the **Show Progress Meter** check box.

Precautions on ink cartridge replacement

Read all the instructions in this section before replacing the ink cartridges.

- ❑ This product uses ink cartridges equipped with an IC chip that monitors the amount of ink used by each cartridge. Cartridges are usable even if they are removed and reinserted. However, some ink is consumed each time cartridges are inserted, because the product automatically checks their reliability.
- ❑ The valve in the ink supply port is designed to contain any excess ink that may be released. However, careful handling is recommended. Do not touch the supply port of the ink cartridge or its surrounding area.
- ❑ Ink is consumed during the following operations: ink charging when an ink cartridge is installed for the first time, print head cleaning, and automatic cleaning executed periodically.

- ❑ For maximum ink efficiency, only remove an ink cartridge when you are ready to replace it.
- ❑ Do not refill the ink cartridges. Other products not manufactured by Epson may cause damage that is not covered by Epson's warranties, and under certain circumstances, may cause erratic product behavior.
- ❑ Keep ink cartridges out of the reach of children and do not drink the ink.
- ❑ Be careful when you handle used ink cartridges, as there may be some ink around the ink supply port. If ink gets on your skin, wash the area thoroughly with soap and water. If ink gets into your eyes, flush them immediately with water. If discomfort or vision problems continue after a thorough flushing, see a doctor immediately.
- ❑ Epson recommends the use of genuine Epson ink cartridges. The use of non-genuine ink may cause damage that is not covered by Epson's warranties, and under certain circumstances, may cause erratic product behavior. Epson cannot guarantee the quality or reliability of non-genuine ink. The ink cartridge status is not displayed when non-genuine ink is used.
- ❑ Do not open the ink cartridge package until you are ready to install it in the product.
- ❑ Use ink cartridges within six months after installing them in the printer.
- ❑ Leave the old cartridge installed in the product until you have obtained a replacement; otherwise, ink remaining in the print head nozzles may dry out.
- ❑ You cannot continue printing if any of the ink cartridges has reached its replacement time, even if the other cartridges still contain ink. Before printing, replace the used cartridge.
- ❑ Do not turn off the product or open the ink cartridge cover while loading ink (On light is flashing). Opening the covers may cause the ink to reload, resulting in more of the ink being consumed. Also, normal printing may be disturbed.
- ❑ If the ink cartridge is not recognized even if it is correctly installed, dirt may be attached to the green IC chip. Remove the cartridge, wipe the IC chip with a soft cloth, and install it again.
- ❑ Color adjustment of the product is based on the use of genuine Epson ink cartridges. Use of non-genuine ink cartridges may result in reduced print quality and the product performance may not be optimum.
- ❑ When an Ink light is flashing or lit, the ink cartridge is not correctly installed. Check that it is installed correctly.
- ❑ If installing an ink cartridge does not provide normal printing, press the **Cleaning** button for three seconds. If it does not resolve the problem, repeat the process one or two times.

- ❑ When the printer is turned off using the **On** button, the print head is automatically covered to prevent the ink from drying. If you will not use the printer after installing the ink cartridges, make sure to turn off the printer using the **On** button. Do not unplug the power cord or turn off the circuit breaker while the power is on.
- ❑ When moving or transporting the printer after installing the ink cartridges, leave the ink cartridges installed.
- ❑ During printing, the black ink cartridge with the most ink remaining is used (GP-M830/GP-M831/GP-M832 only).
- ❑ You cannot print when either black ink cartridge has reached its replacement time (GP-M830/GP-M831/GP-M832 only).

Replacing an ink cartridge

Note:

- ❑ Do not open the ink cartridge package until you are ready to install it in the product.
- ❑ To confirm the status of each ink cartridge, see “Checking the ink cartridge status” on page 71.

This table describes the status of the Ink lights and the actions you need to take.

Lights	Action
◐	Ink is low. Obtain a replacement ink cartridge.
○	The ink cartridge has reached its replacement time. Replace the ink cartridge.

◐ : flashing ○ : on

Follow these steps to replace an ink cartridge.



Caution:

Do not remove the cartridge from the product until you are ready to replace it with another.

Note:

- ❑ The illustrations show replacement of the black ink cartridge of the left ink slot, but the instructions are the same for all the cartridges.
 - ❑ When installing an ink cartridge into the GP-C830/GP-C831/GP-C832, make sure that the color of the cartridge matches the color of the label that is affixed to the printer.
1. Make sure that the On light is on, but not flashing.

2. Open the ink cartridge cover.

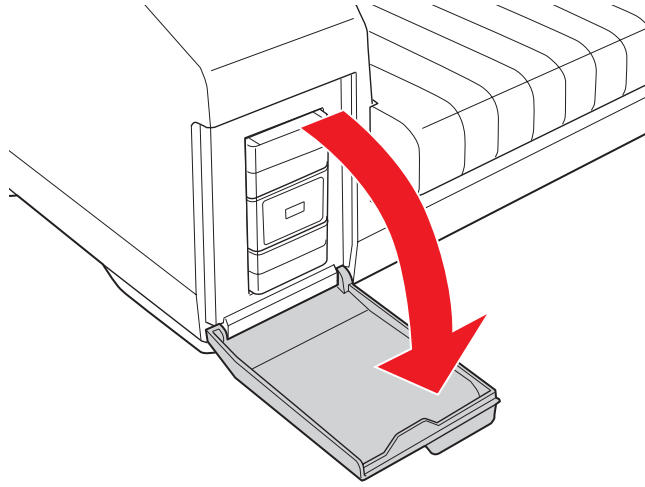

Note:

Wait for four seconds or more before removing the ink cartridge. Otherwise, ink may squirt.

3. Push in the used cartridge so the cartridge pops out slightly.

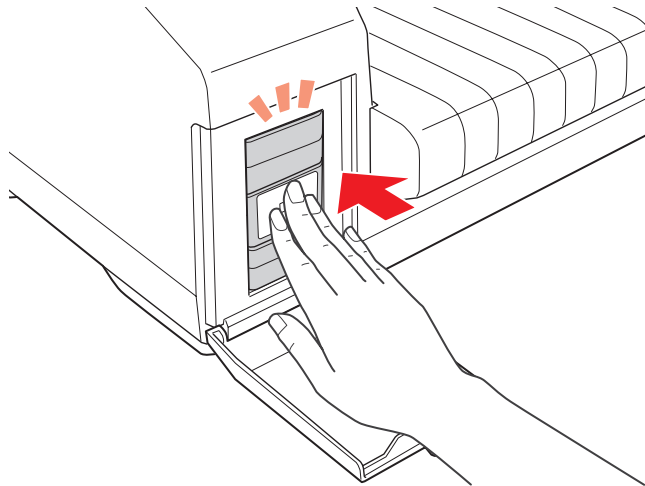

- Carefully pull the used cartridge straight out of the slot. Dispose of it properly.

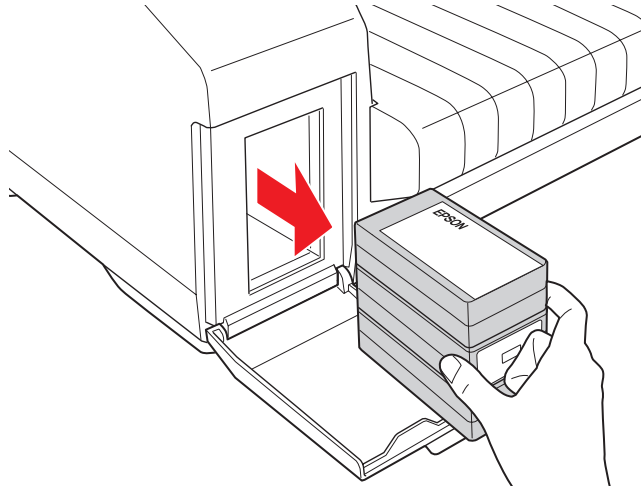

- For best results, shake the new ink cartridge four or five times.

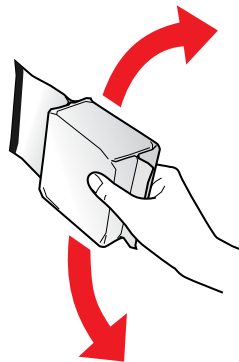

- Remove the new ink cartridge from the package.

**Caution:**

- ❑ Do not touch the green IC chip on the side of the cartridge. This can damage the ink cartridge.

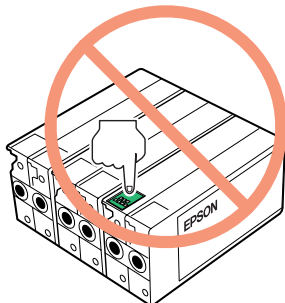

- ❑ Always install an ink cartridge immediately after removing the old cartridge. If the cartridge is not installed promptly, you may not be able to print.
- ❑ Do not refill the ink cartridge. Other products not manufactured by Epson may cause damage that is not covered by Epson's warranties, and under certain circumstances, may cause erratic product behavior.

7. Place the new ink cartridge into the slot. Then, push the ink cartridge until it clicks into place.

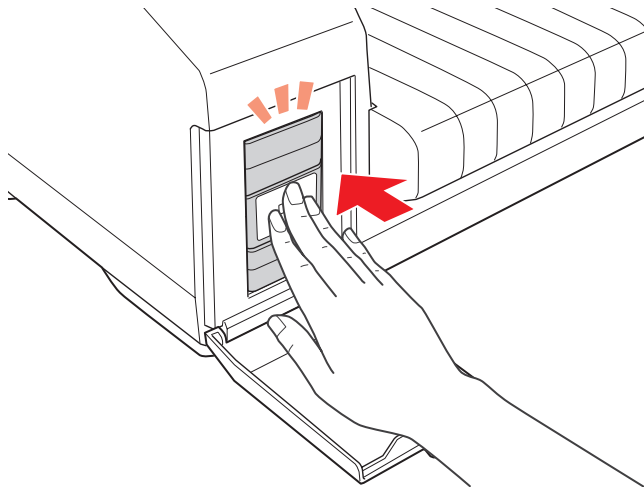

8. Close the ink cartridge cover.

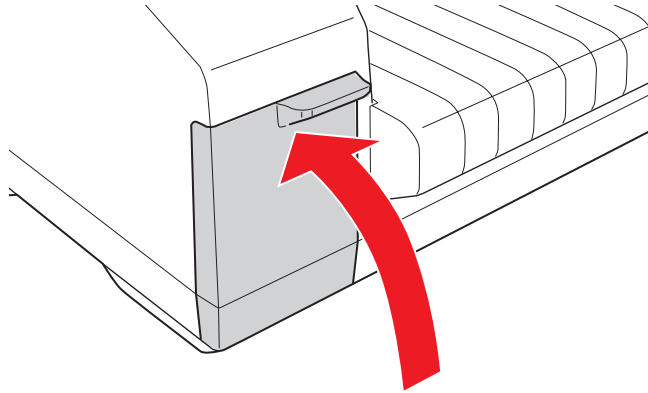

Chapter 9

Product Information

Printer Parts

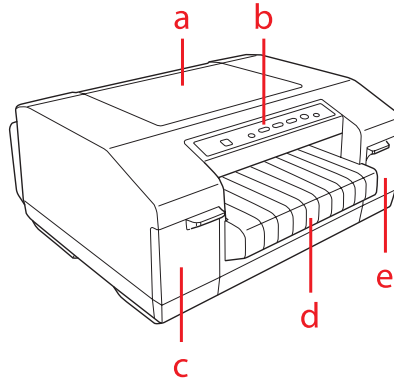

- a. top cover
- b. control panel
- c. ink cartridge cover (left)
- d. output tray
- e. ink cartridge cover (right)

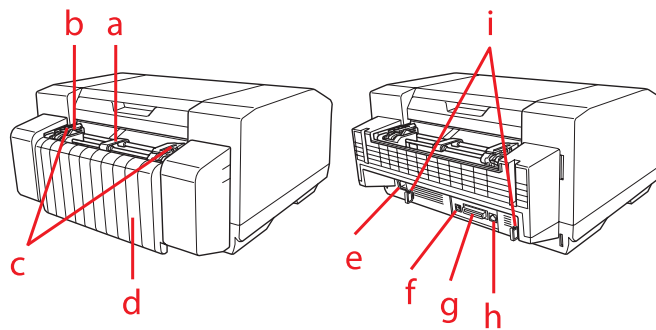

- a. center paper support*
- b. paper sensor

- c. sprockets*
 - d. connector cover
 - e. power plug connector
 - f. USB interface connector
 - g. parallel interface connector
 - h. ethernet interface connector
 - i. cable holders
- * tractor unit parts

Printer Specifications

Mechanical

Printing method:	Serial ink jet	
Printing speed:	Print quality: Super Draft/ Draft	450 cps
	Print quality: Normal/ Fine	360 cps
	Print quality: Extra Fine 1/ Extra Fine 2/ Extra Fine 3	200 cps
Printing direction:	Bidirectional, unidirectional	
Printable columns:	80 columns (at 10 cpi)	

Resolution:	Print quality:	360 × 360 dpi
	Super Draft/ Draft/ Normal	
	Print quality:	360 × 720 dpi
	Fine	
Resolution:	Print quality:	720 × 720 dpi
	Extra Fine 1/ Extra Fine 2	
	Print quality:	5760 × 1440 dpi
	Extra Fine 3	
Feeding method:	Push tractor feed (rear paper entry)	
Feeder:	Rear push tractor	
Paper feed speed:	Normal mode:	
	Intermittent	25.4 mm/line at 1-inch line spacing
	Continuous feed	381 mm/second (15 inches/second)
Reliability:	Total print volume	0.6 million sheets (paper size: 241.3 × 279.4 mm (9.5 × 11.0 inches))
Dimensions and weight:	Height	224 mm (8.82 inches)
	Width	464 mm (18.27 inches)
	Depth	465 mm (18.30 inches)
	Weight	Approx. 12.2 kg (26.9 lb) (without the ink cartridges)

Ink cartridges:	Color: GP-C830/GP-C831/ GP-C832	Black, Yellow, Magenta, Cyan
	Color: GP-M830/ GP-M831/GP-M832	Black
	Cartridge life	Use within 6 months after installing in the printer.
	Temperature	Operation: 10 to 35 °C (50 to 95 °F)

Electronic



Caution:

For the Ethernet cable, use a cable with CAT5e shielding.

Interfaces:	One standard bidirectional, 8-bit, parallel interface with IEEE-1284 nibble mode and high-speed communication support, one USB2.0 (High Speed) interface, and the 100BASE-TX/10BASE-T interface.
Buffer:	64 KB or more

Built-in fonts:

For Indian users

Bitmap fonts:

EPSON Draft 10, 12, 15 cpi
 EPSON Roman 10, 12, 15 cpi, proportional
 EPSON Sans Serif 10, 12, 15 cpi, proportional
 EPSON Courier 10, 12, 15 cpi
 EPSON Prestige 10, 12 cpi
 EPSON Script 10 cpi
 EPSON OCR-B 10 cpi
 EPSON Orator 10 cpi
 EPSON Orator-S 10 cpi
 EPSON Script C proportional

Indian fonts^{*1}:

CDAC Devanagari proportional^{*2}
 CDAC Bengali proportional^{*2}
 CDAC Tamil proportional^{*2}
 CDAC Telugu proportional^{*2}
 CDAC Assamese proportional^{*2}
 CDAC Oriya proportional^{*2}
 CDAC Kannada proportional^{*2}
 CDAC Malayalam proportional^{*2}
 CDAC Gujarati proportional^{*2}
 CDAC Punjabi proportional^{*2}

*1 These fonts are available for Indian model only.

*2 Each font has two sizes (14 pt and 10.5 pt) and two qualities (LQ and Draft).

Scalable fonts:

EPSON Roman 10.5, 8-32 pt (every 2 pt)
 EPSON Sans Serif 10.5, 8-32 pt (every 2 pt)
 EPSON Roman T 10.5, 8-32 pt (every 2 pt)
 EPSON Sans Serif H 10.5, 8-32 pt (every 2 pt)

Barcode fonts:

EAN-13, EAN-8, Interleaved 2 of 5, UPC-A, UPC-E, Code 39,
 Code 128, POSTNET

For Thai users

Bitmap fonts:

EPSON Draft 10, 12, 15 cpi
EPSON Roman 10, 12, 15 cpi, proportional
EPSON Sans Serif 10, 12, 15 cpi, proportional
EPSON Courier 10, 12, 15 cpi
EPSON Prestige 10, 12 cpi
EPSON Script 10 cpi
EPSON OCR-B 10 cpi
EPSON Orator 10 cpi
EPSON Orator-S 10 cpi
EPSON Script C proportional

Scalable fonts:

EPSON Roman 10.5, 8-32 pt (every 2 pt)
EPSON Sans Serif 10.5, 8-32 pt (every 2 pt)
EPSON Roman T 10.5, 8-32 pt (every 2 pt)
EPSON Sans Serif H 10.5, 8-32 pt (every 2 pt)
SV Busaba 10.5, 8-32 pt (every 2 pt)^{*1}
SV Jittra 10.5, 8-32 pt (every 2 pt)^{*1}

Barcode fonts:

EAN-13, EAN-8, Interleaved 2 of 5, UPC-A, UPC-E,
Code 39, Code 128, POSTNET

*1 These fonts are available for Thai model only.

For Taiwanese users

Bitmap fonts:

EPSON Draft 10, 12, 15 cpi

EPSON Roman 10, 12, 15 cpi, proportional

EPSON Sans Serif 10, 12, 15 cpi, proportional

EPSON Courier 10, 12, 15 cpi

EPSON Prestige 10, 12 cpi

EPSON Script 10 cpi

EPSON OCR-B 10 cpi

Traditional Chinese fonts:

宋體

黑體

楷體

隸書

Scalable fonts:

EPSON Roman 10.5, 8-32 pt (every 2 pt)

EPSON Sans Serif 10.5, 8-32 pt (every 2 pt)

EPSON Roman T 10.5, 8-32 pt (every 2 pt)

EPSON Sans Serif H 10.5, 8-32 pt (every 2 pt)

Barcode fonts:

EAN-13, EAN-8, Interleaved 2 of 5, UPC-A, UPC-E, Code 39,
Code 128, POSTNET

For Chinese users

Bitmap fonts:

EPSON Draft 10, 12, 15 cpi

EPSON Roman 10, 12, 15 cpi, proportional

EPSON Sans Serif 10, 12, 15 cpi, proportional

EPSON OCR-B 10 cpi

Simplified Chinese fonts:

宋体

黑体

Scalable fonts:

EPSON Roman 10.5, 8-32 pt (every 2 pt)

EPSON Sans Serif 10.5, 8-32 pt (every 2 pt)

EPSON Roman T 10.5, 8-32 pt (every 2 pt)

EPSON Sans Serif H 10.5, 8-32 pt (every 2 pt)

Barcode fonts:

EAN-13, EAN-8, Interleaved 2 of 5, UPC-A, UPC-E, Code 39,
Code 128, POSTNET

For other users

Bitmap fonts:

EPSON Draft 10, 12, 15 cpi
 EPSON Roman 10, 12, 15 cpi, proportional
 EPSON Sans Serif 10, 12, 15 cpi, proportional
 EPSON Courier 10, 12, 15 cpi
 EPSON Prestige 10, 12 cpi
 EPSON Script 10 cpi
 EPSON OCR-B 10 cpi
 EPSON Orator 10 cpi
 EPSON Orator-S 10 cpi
 EPSON Script C proportional

Scalable fonts:

EPSON Roman 10.5, 8-32 pt (every 2 pt)
 EPSON Sans Serif 10.5, 8-32 pt (every 2 pt)
 EPSON Roman T 10.5, 8-32 pt (every 2 pt)
 EPSON Sans Serif H 10.5, 8-32 pt (every 2 pt)

Barcode fonts:

EAN-13, EAN-8, Interleaved 2 of 5, UPC-A, UPC-E, Code 39,
 Code 128, POSTNET

Character tables:

One Italic and 12 graphical character tables. (34 graphical character tables are available in some countries.) See “Character Tables” on page 94 for more information on the available character tables.

Character sets:

14 international character sets and one legal character set

Electrical

Supply voltage*	DC 42 V
Rated current	1.0 A

* Be sure to use the included AC Adapter K (M248A).

AC power consumption	Approx. 33 W (ISO24712 pattern) Approx. 8 W in standby mode Approx. 2.9 W in sleep mode* Approx. 0.2 W in power-off mode
----------------------	---

* When three minutes pass in the following conditions, the printer enters sleep mode.

- No error
- There is no data in input buffer
- Ink cartridge covers are closed
- Top cover is closed

Environmental

	Temperature (without condensation)	Humidity (without condensation)
Operation	10 to 35 °C (50 to 95 °F)	20 to 80% RH
Storage	-20 to 40 °C (-4 to 104 °F)	5 to 85% RH

Paper

Note:

- Do not load paper that has been folded or is damaged, wrinkled, or curled.
- Medicine bags may become dirty when printing in an environment with high humidity if the backside of the medicine bags is a polyvinyl resin.

Continuous paper:

Width	76.2 to 241.3 mm (3.0 to 9.5 inches)
Length (one page)	12.7 to 558.8 mm (0.5 to 22.0 inches)*
Thickness	0.065 to 0.14 mm (0.0025 to 0.0055 inch)
Weight	52 to 129 g/m ² (14 to 34.3 lb)
Quality	Plain paper, Reclaimed paper Not broken, torn, turned over, or wrinkled

* You cannot load continuous paper if 139.7 mm (5.5 inches) or less remains.

Labels (continuous base sheet):

Label size	38.1 mm (1.5 inches) in height, minimum 50.8 mm (2.0 inches) in width, minimum 2.5 mm (0.1 inch) corner radius, minimum
Base sheet width	76.2 to 241.3 mm (3.0 to 9.5 inches)
Base sheet length	38.1 to 558.8 mm (1.5 to 22.0 inches)
Base sheet thickness	0.076 to 0.14 mm (0.003 to 0.0055 inch)*
Total thickness	0.143 to 0.225 mm (0.0056 to 0.0089 inch)
Label weight	63 to 190 g/m ² (17 to 28 lb)

* Print in an environment with humidity of 55% or less when using labels that have a continuous base sheet with a thickness of 0.058 to 0.075 mm.

Note:

- Use only labels that are designed for use with ink jet printers.
- Epson recommends using labels with a base sheet that is not covered with label material.

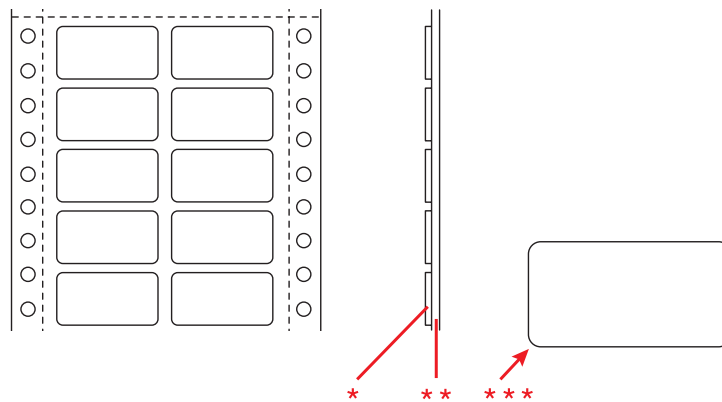

* label

** base sheet

*** corner radius: 2.5 mm (0.1 inch) or more

Medicine bag (continuous):

Width	76.2 to 241.3 mm (3.0 to 9.5 inches)
-------	--------------------------------------

Length (one page)	12.7 to 558.8 mm (0.5 to 22.0 inches)*
Thickness	0.11 to 0.13 mm (0.0043 to 0.0051 inches)
Weight	63 to 104.7 g/m ² (17 to 28 lb)
Quality	Plain paper, Reclaimed paper Not broken, torn, turned over, or wrinkled

* You cannot load continuous paper if 139.7 mm (5.5 inches) or less remains.

Pre-printed Paper

Pre-printed paper is paper that has ruled lines, letters, or figures printed in the top and bottom margins. The middle of the paper is left blank. The margin areas are often used for letterheads, borders, and so on. You can make your own pre-printed paper or you can purchase it.

You cannot use pre-printed paper if the areas shown with diagonal lines in the illustration below have been printed on.

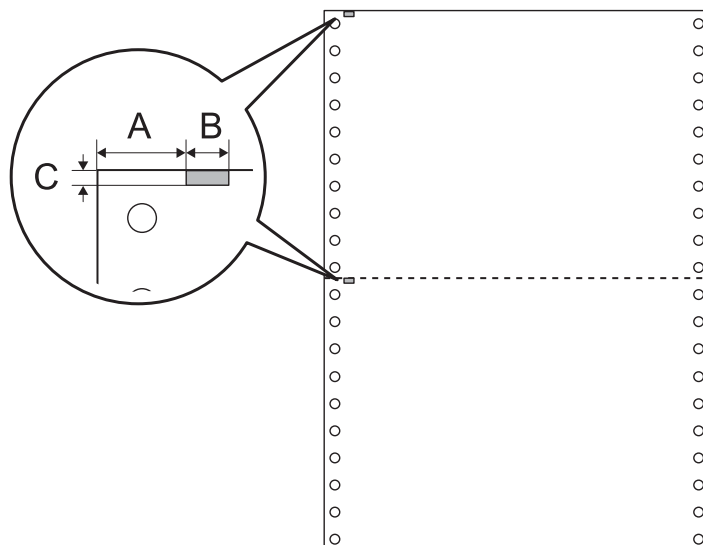

Area measurements

- A 12.5 mm (0.492 inch)
- B 6 mm (0.236 inch)

C 2 mm (0.079 inch)

Printable area

Continuous paper:

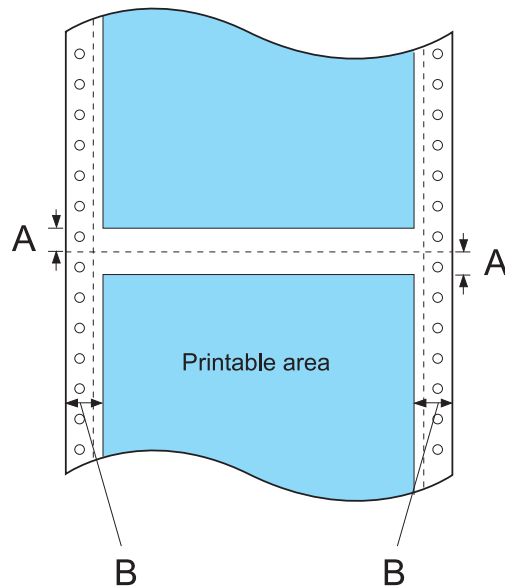

- A The minimum top and bottom margins above and below the perforation are 2.0 mm (0.079 inch) each.
- B The minimum left and right margins are 13 mm (0.51 inch) each.

The maximum paper width is 241.3 mm (9.5 inches) and the maximum printable width is 203.2 mm (8.0 inches).

For continuous paper wider than 229.2 mm (9.02 inches), the right margins increase proportionally to match the width of the paper.

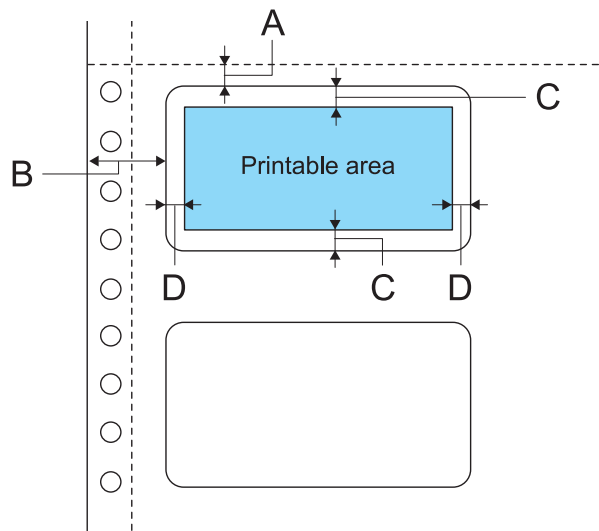
Label (continuous base sheet):

- A 2 mm (0.0787 inch) or more
- B 12.7 mm (0.5 inch) or more
- C 2 mm(0.0787 inch) or more
- D 1.5 mm (0.0591 inch) or more

AC Adapter Electrical Specifications

Use the specified AC Adapter (EPSON AC Adapter K, Model: M248A) only.

Input	Rated voltage	AC 100 to 240 V
	Rated frequency	50-60 Hz
	Rated current	1.6 A
Output	Supply voltage	DC 42 V
	Rated current	1.38 A

Command Lists

For information about the commands, please access <http://www.epson.com>.

Character Tables

You can select the character tables and character sets below.

Character tables: For Indian users

One Italic and 17 graphical character tables:
Italic table, PC437 (US, Standard Europe), PC850 (Multilingual), PC860 (Portuguese), PC861 (Icelandic), PC863 (Canadian-French), PC865 (Nordic), BRASCII, Abicomp, Roman 8, ISO Latin 1, PC858, ISO 8859-15, ISCII, PC-ISCII, EA-ISCII, TAB-Tamil99, TAM-Tamil99

For Thai users

One Italic and 14 graphical character tables:
Italic table, PC437 (US, Standard Europe), PC850 (Multilingual), PC860 (Portuguese), PC863 (Canadian-French), PC865 (Nordic), PC 858, ISO 8859-15, KU42 (Thai), TIS11 (Thai), TIS18 (Thai), TIS17 (Thai), TIS13 (Thai), TIS16 (Thai), TSM/WIN (Thai)

For Taiwanese users

One Italic and eight graphical character tables:
Italic table, PC437 (US Standard Europe), PC850 (Multilingual), PC858 (Multilingual Euro), NS, TCA, BIG-5, IBM5550, DCI

For Chinese users

One Italic and eight graphical character tables:
Italic table, PC437 (US, Standard Europe), PC850 (Multilingual), PC860 (Portuguese), PC863 (Canadian-French), PC865 (Nordic), PC858 (Multilingual Euro), GB18030

For other users

Standard version:

One Italic and 12 graphical character tables:

Italic table, PC437 (US Standard Europe), PC850 (Multilingual), PC860 (Portuguese), PC861 (Icelandic), PC863 (Canadian-French), PC865 (Nordic), Abicomp, BRASCII, Roman 8, ISO Latin 1, PC858, ISO 8859-15

NLSP version:

One Italic and 39 graphical character tables:

Italic table, PC437 (US Standard Europe), PC850 (Multilingual), PC860 (Portuguese), PC861 (Icelandic), PC863 (Canadian-French), PC865 (Nordic), Abicomp, BRASCII, Roman 8, ISO Latin 1, PC858, ISO 8859-15, PC437 Greek, PC852 (East Europe), PC853 (Turkish), PC855 (Cyrillic), PC857 (Turkish), PC866 (Russian), PC869 (Greek), MAZOWIA (Poland), Code MJK (CSFR), ISO 8859-7 (Latin/Greek), ISO Latin 1T (Turkish), Bulgaria (Bulgarian), Estonia (Estonia), PC 774 (LST 1283:1993), ISO 8859-2, PC866 LAT. (Latvian), PC866 UKR (Ukraine), PC771 (Lithuania), PC437 Slovenia, PC MC, PC1250, PC1251, PC864 (Arabic), PCAPTEC (Arabic), PC708 (Arabic), PC720 (Arabic), PCAR864 (Arabic)

Character sets:

14 international character sets and one legal character sets.

USA, France, Germany, UK, Denmark 1, Sweden, Italy, Spain 1, Japan, Norway, Denmark 2, Spain 2, Latin America, Korea, Legal

Standards and Approvals

WARNING:

- This is a Class A product. In a domestic environment this product may cause radio interference in which case the user may be required to take adequate measures.
- The connection of a non-shielded printer interface cable to this printer will invalidate the EMC standards of this device.

- ❑ You are cautioned that changes or modifications not expressly approved by Seiko Epson Corporation could void your authority to operate the equipment.

Taiwan

EMC	CNS13438 Class A
Safety	CNS14336-1

North America

EMI	FCC/ICES-003 Class A
-----	----------------------

FCC compliance statement for United States users

This equipment has been tested and found to comply with the limits for a Class A digital device, pursuant to Part 15 of the FCC Rules. These limits are designed to provide reasonable protection against harmful interference when the equipment is operated in a commercial environment. This equipment generates, uses, and can radiate radio frequency energy and, if not installed and used in accordance with the instruction manual, may cause harmful interference to radio communications. Operation of this equipment in a residential area is likely to cause harmful interference, in which case the user will be required to correct the interference at his own expense.

This device complies with Part 15 of the FCC Rules. Operation is subject to the following two conditions:

- (1) this device may not cause harmful interference, and
- (2) this device must accept any interference received, including interference that may cause undesired operation.

For Canadian users

This Class A digital apparatus complies with Canadian ICES-003.

Cet appareil numérique de la classe A est conforme à la norme NMB-003 du Canada.

Europe

EMC Directive 2004/108/EC

EN 55022 Class A
EN 55024

IEC 61000-4-2

IEC 61000-4-3

IEC 61000-4-4

IEC 61000-4-5

IEC 61000-4-6

IEC 61000-4-11

Checking the Print Head Nozzles

If you find that the printout is unexpectedly faint or that dots are missing, you may be able to identify the problem by checking the print head nozzles.

You can check the print head nozzles from your computer using the Nozzle Check utility in the printer driver or from the printer using the control panel buttons.

Note:

When you print a nozzle check pattern, use paper with a width of 116.8 mm (4.6 inches) or more.

Using the Nozzle Check utility for Windows

Follow these steps to use the Nozzle Check utility.

1. Make sure that no lights are indicating errors.
2. Make sure that paper is attached to the tractor unit.
3. Access the printer driver. See “Using the Printer Driver” on page 26.
4. Click the **Utility** tab, and then click the **Nozzle Check** button.
5. Follow the on-screen instructions.

Using the control panel

Follow these steps to check the print head nozzles using the control panel.

1. Make sure that paper is attached to the tractor unit.
2. While pressing the **Load/Eject** button, press the **On** button until the **On** light flashes.

Below are two sample nozzle check patterns.

Compare the quality of the printed check page with the sample shown below. If there are no print quality problems, such as gaps or missing segments in the test lines, the print head is fine.

GP-C830/GP-C831/GP-C832

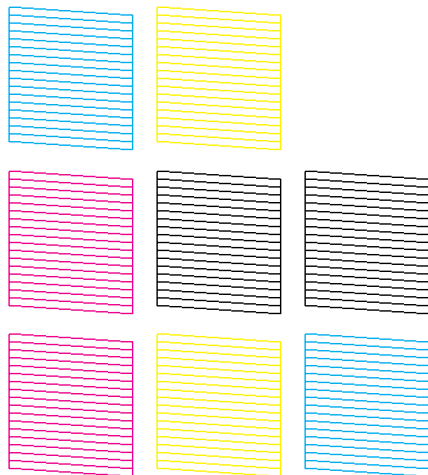

GP-M830/GP-M831/GP-M832

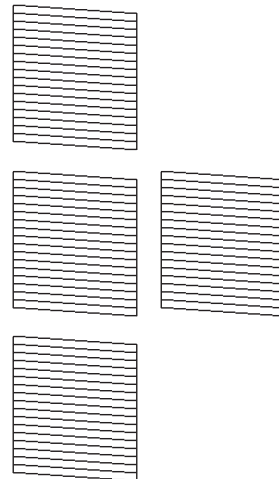

If any segment of the printed lines is missing, as shown below, this could mean that an ink nozzle is clogged. See “Cleaning the Print Head” on page 99.

GP-C830/GP-C831/GP-C832

GP-M830/GP-M831/GP-M832

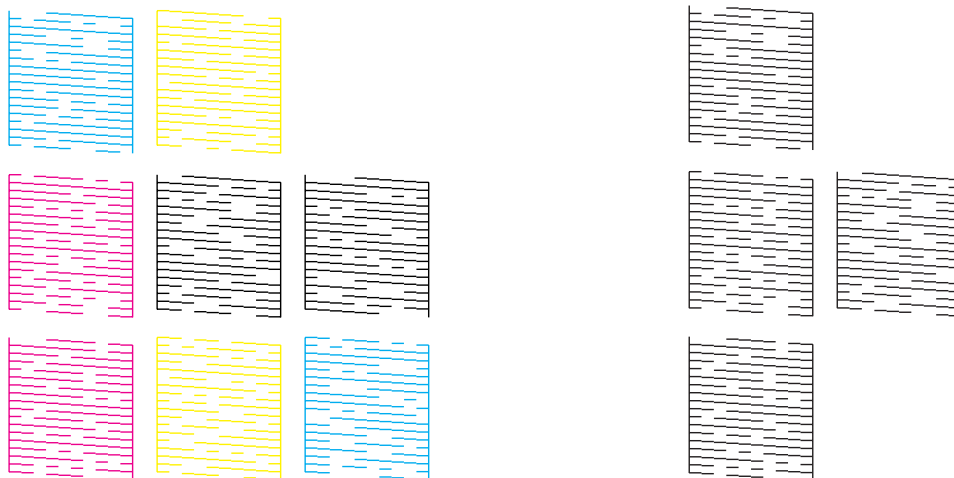

Cleaning the Print Head

If you find that the printout is unexpectedly faint or that dots are missing, you may be able to solve these problems by cleaning the print head, which ensures that the nozzles are delivering ink properly.

You can clean the print head from your computer using the Head Cleaning utility in the printer driver or from the printer using the control panel buttons.

Note:

- Because print head cleaning uses ink from all cartridges, clean the print head only if print quality declines; for example, if the printout is blurry, the color is incorrect or missing, or the vertical lines are pronouncedly misaligned.
- Use the Nozzle Check utility first to confirm that the print head needs to be cleaned. This saves ink.
- When ink is low, you may not be able to clean the print head. When ink is expended, you cannot clean the print head. Replace the appropriate ink cartridge first. For more information, see “Replacing an ink cartridge” on page 75.

Using the Head Cleaning utility for Windows

Follow these steps to clean the print head using the Head Cleaning utility.

1. Turn on the printer.

2. Make sure that no lights are indicating errors.
3. Access the printer driver. See “Using the Printer Driver” on page 26.
4. Click the **Utility** tab, and then click the **Head Cleaning** button.
5. Follow the on-screen instructions.

The **On** light flashes while the printer performs the cleaning cycle.



Caution:

- Never turn off the printer while the **On** light is flashing. Doing so may damage the printer.
- Never open the top cover or ink cartridge cover while the **On** light is flashing.

Note:

- If print quality has not improved after repeating this procedure, turn off the printer and wait for at least six hours. Then, run the nozzle check again and repeat the head cleaning if necessary.
- If print quality remains a problem, contact Epson Service Center. For more information, see “Contacting Customer Support” on page 64.
- To maintain print quality, Epson recommends printing a few pages on a regular basis.

Using the control panel

Follow these steps to clean the print head using the control panel.

1. Hold down the **Cleaning** button for about three seconds.



Caution:

- Never turn off the printer while the **On** light is flashing. Doing so may damage the printer.
 - Never open the top cover or ink cartridge cover while the **On** light is flashing.
2. When the **On** light stops flashing, print a nozzle check pattern to confirm that the head is clean. For more information, see “Checking the Print Head Nozzles” on page 97.

Note:

- If print quality has not improved after repeating this procedure, turn off the printer and wait for at least six hours. Then, run the nozzle check again and repeat the head cleaning if necessary.

- ❑ *If print quality remains a problem, contact Epson Service Center. For more information, see “Contacting Customer Support” on page 64.*
- ❑ *To maintain print quality, Epson recommends printing a few pages on a regular basis.*

Aligning the Print Head

Adjusting the media feed

If you notice a misalignment of vertical lines or horizontal banding, you may be able to solve this problem by aligning the print head.

You can align the print head from your computer using the Print Head Alignment utility in your printer driver.

Note:

If you notice a pronounced misalignment of vertical lines, be sure to clean the print head first. For more information, see “Cleaning the Print Head” on page 99.

Follow these steps to align the print head using the Print Head Alignment utility.

1. Make sure that no lights are indicating errors.
2. Make sure that paper is attached to the tractor unit.
3. Access the printer driver. See “Using the Printer Driver” on page 26.
4. Click the **Utility** tab, and then click the **Print Head Alignment** button.
5. Select **Media Feed Adjustment**, and then click **Next**.
6. Follow the on-screen instructions.

Adjusting the bi-directional printing

This utility tool allows you to make adjustments if the vertical lines are misaligned.

Follow these steps to use Bi-D Adjustment.

**Caution:**

Do not turn off the printer while the printer is printing the adjustment patterns. Doing so may cause the printer to store incorrect settings. If you turned off the printer during the adjustment process, start Bi-D Adjustment again.

1. Make sure that no lights are indicating errors.
2. Make sure that paper is attached to the tractor unit.
3. Access the printer driver. See “Using the Printer Driver” on page 26.
4. Click the **Utility** tab, and then click the **Print Head Alignment** button.
5. Select **Bi-directional Printing Adjustment**, and then click **Next**.
6. Follow the on-screen instructions.

Note:

*Bi-directional printing may not be adjusted correctly if the paper is wavy. Clear the **High Speed** check box in the printer driver dialog box to perform adjustments correctly.*

Printing the Status Sheet

You can print a status sheet to check the detailed information on the printer status. You can print three types of status sheets.

Note:

When you print a status sheet, use paper with a width of 114.3 mm (4.5 inches) or more.

General information

The serial number, firmware version, and total print volume are printed on the status sheet.

1. Turn off the printer.
2. Make sure that paper is attached to the tractor unit.
3. While pressing the **FF** button, press the **On** button until the **On** light flashes.

Network settings

The information for the network settings, such as the MAC address, IP address, and security settings, are printed on the status sheet.

1. Make sure that paper is attached to the tractor unit and that the printer is turned on.
2. Press the **Tear Off** button and **Load/Eject** button at the same time for three seconds.

Printer settings

The current printer settings are printed on the status sheet.

1. Turn off the printer.
2. Make sure that paper is attached to the tractor unit.
3. While pressing the **Cleaning** button, press the **On** button until the **On** light flashes.

Initializing the Network Setting

When network connection fails, follow the step below to initialize the network setting to the default.

1. Turn off the printer.
2. While pressing the **Tear Off** button and **Load/Eject** button, press the **On** button.



Caution:

The initialization takes about 30 seconds. Do not turn off the printer during the initialization.

Cleaning the Printer

To keep your printer operating at its best, you should clean it thoroughly several times a year.

Cleaning the outer case



Caution:

- Never use alcohols or thinners to clean the printer; these chemicals can damage the printer components as well as the case.
- Be careful not to get water onto the printer mechanism or electronic components.

1. Turn off the printer and remove any paper loaded in the printer.
2. Clean the outer case with a dry cloth. If the outer case is still dirty or dusty, clean it with a clean cloth dampened with a mild detergent dissolved in water.

Cleaning the inside of the printer



Caution:

- Never use alcohols or thinners to clean the printer; these chemicals can damage the printer components as well as the case.
- Be careful not to get water onto the printer mechanism or electronic components.
- Do not use a hard or abrasive brush.
- Do not spray the inside of the printer with lubricants; unsuitable lubricants can damage the printer mechanism. Contact an Epson dealer if you think lubrication is needed.

Follow these steps to clean your printer.

1. Turn off the printer and remove any paper loaded in the printer.
2. Slide the right sprocket unit completely to the right.

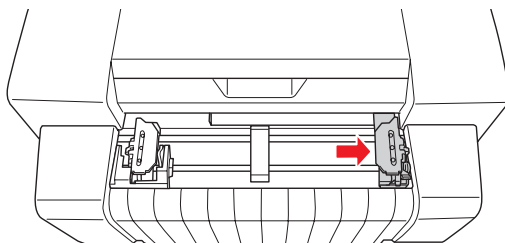

3. Use a soft brush to carefully brush away all dust and dirt from the outer case.

**Caution:**

- ❑ When cleaning the printer using a brush, be careful not to touch the linear scale or the carriage shafts with the brush and make sure that dust does not adhere to the shafts. Otherwise, the print quality may be adversely affected.
- ❑ Do not brush any dust toward the print head. Brush dust that is near the print head forward or backward away from the head.

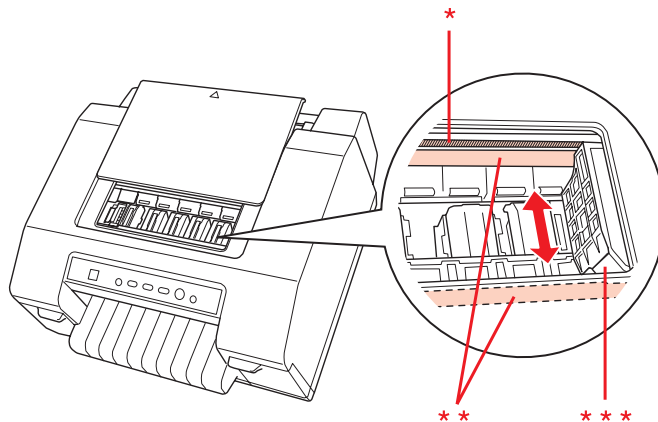

* linear scale

** carriage shaft

*** print head

4. Slide the right sprocket unit completely to the left.

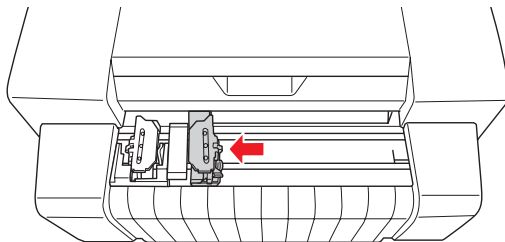

5. Clean the scale with a soft cloth.

**Caution:**

When cleaning the scale, be careful not to touch or damage the linear scale or the carriage shafts.

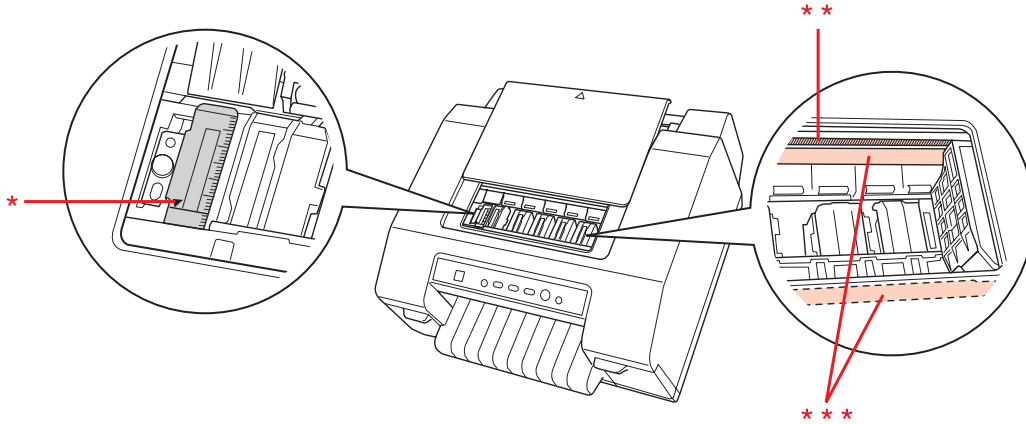

* scale

** linear scale

*** carriage shaft

Cleaning the paper feed rollers

Dirty paper feed rollers may cause paper jams or dirty printouts. Follow these steps to clean the paper feed rollers.

**Caution:**

- Be careful not to get water onto the printer mechanism or electronic components.
- Do not spray the inside of the printer with lubricants; unsuitable lubricants can damage the printer mechanism. Contact an Epson dealer if you think lubrication is needed.

1. Turn off the printer and attach the paper to the tractor unit.
2. Turn on the printer.
3. Press the **Load/Eject** button to feed the paper to the top-of-form position.
4. Press the **Tear Off** button to advance the perforation of the paper to the tear-off position.
5. Open the top cover.

6. Hold down the **Pause** button for about three seconds. The **Pause** light flashes and the printer enters Micro Adjust mode.
7. Clean the paper feed rollers with a cotton-tipped applicator dampened with alcohol (ethanol or isopropyl alcohol).

Press the **FF** button or **Load/Eject** button to rotate the rollers while cleaning them.



Caution:

When cleaning the paper feed rollers, be careful not to touch or damage the linear scale or the carriage shafts.

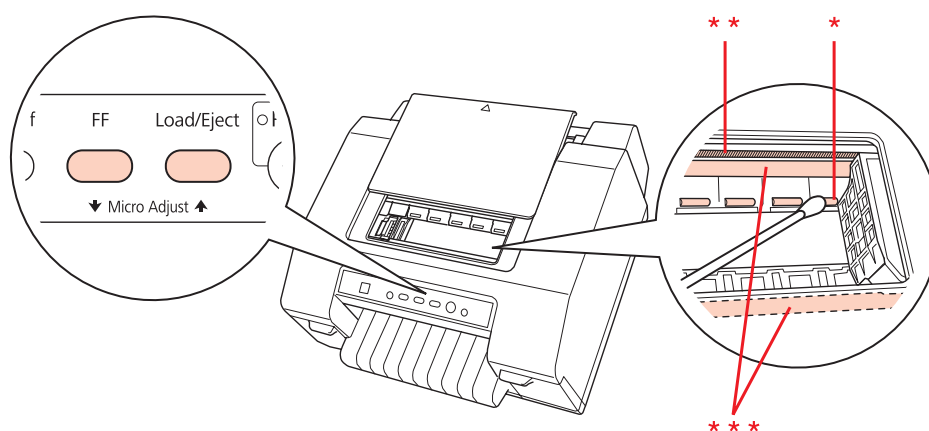

* paper feed roller

** linear scale

*** carriage shaft

8. Turn off the printer.

Transporting the Printer

If you need to transport your printer for some distance, carefully repack it using the original box and packing materials.

Follow these steps to repack the printer in its original packing materials.



Caution:

Leave the ink cartridges installed. Removing the cartridges may cause ink to leak and adversely affect the print quality.

1. Press the **Load/Eject** button and remove any paper loaded in the printer.
2. Turn off the printer.
3. Unplug the power cord from the electrical outlet, and then disconnect the interface cable from the printer.
4. Repack the printer and power cord in their original packing materials and place them in the printer's original box.

Copyright and Trademarks

No part of this publication may be reproduced, stored in a retrieval system, or transmitted in any form or by any means, electronic, mechanical, photocopying, recording, or otherwise, without the prior written permission of Seiko Epson Corporation. The information contained herein is designed only for use with this Epson printer. Epson is not responsible for any use of this information as applied to other printers.

Neither Seiko Epson Corporation nor its affiliates shall be liable to the purchaser of this product or third parties for damages, losses, costs, or expenses incurred by the purchaser or third parties as a result of: accident, misuse, or abuse of this product or unauthorized modifications, repairs, or alterations to this product, or (excluding the U.S.) failure to strictly comply with Seiko Epson Corporation's operating and maintenance instructions.

Seiko Epson Corporation shall not be liable for any damages or problems arising from the use of any options or any consumable products other than those designated as Original Epson Products or Epson Approved Products by Seiko Epson Corporation.

EPSON, EXCEED YOUR VISION, and ESC/P are registered trademarks, and ESC/P2 is a trademark of Seiko Epson Corporation in Japan and other countries/regions.

Microsoft®, Windows®, Windows Server®, and Windows Vista® are registered trademarks of Microsoft Corporation in the United States and/or other countries.

General Notice: Other product names used herein are for identification purposes only and may be trademarks of their respective owners. Epson disclaims any and all rights in those marks.

The contents of this manual are subject to change without notice.

Copyright © 2012 Seiko Epson Corporation. All rights reserved.

OPEN SOURCE SOFTWARE LICENSE

1. This printer product includes open source software programs listed in Section 5) according to the license terms of each open source software program.
2. We provide the source code of the GPL Programs, LGPL Programs, Apache License Program and ncftp license Program (each is defined in Section 5) until five (5) years after the discontinuation of same model of this printer product. If you desire to receive the source code above, please contact the customer support of your region. You shall comply with the license terms of each open source software program.
3. The open source software programs are WITHOUT ANY WARRANTY; without even the implied warranty of MERCHANTABILITY AND FITNESS FOR A PARTICULAR PURPOSE. See the license agreements of each open source software program for more details, which are described on \Manual\OSS\OSS.pdf in the Utility & Documents Disk included with the product.

4. The license terms of each open source software program are described on \Manual\OSS \OSS.pdf in the Utility & Documents Disk included with the product.
5. The list of open source software programs which this printer product includes are as follows.

GNU GPL

This printer product includes the open source software programs which apply the GNU General Public License Version 2 or later version (“GPL Programs”).

The list of GPL Programs:

linux-2.6.35-arm1-epson12

busybox-1.17.4

udhcp 0.9.8cvs20050124-5

ethtool-2.6.35

iptables 1.4.10

GNU LGPL

This printer product includes the open source software programs which apply the GNU Lesser General Public License Version 2 or later version (“LGPL Programs”).

The list of LGPL Programs:

uclibc-0.9.32

libusb-1.0.8

zeroconf 0.6.1-1

iksemel-rev25

Apache License

This printer product includes the open source software program “Bonjour” which apply the Apache License Version 2.0 (“Apache License Program”).

Bonjour License

This printer product includes the open source software program “Bonjour” which applies the terms and conditions provided by owner of the copyright to the “Bonjour”.

Net-SNMP license

This printer product includes the open source software program “Net-SNMP” which applies the terms and conditions provided by owner of the copyright to the “Net-SNMP”.

BSD License (Berkeley Software Distribution License)

This printer product includes the open source software program “busybox-1.17.4” which apply the Berkeley Software Distribution License (“BSD Program”).

Sun RPC License

This printer product includes the open source software program “busybox-1.17.4” which apply the Sun RPC License (“Sun RPC Program”).

ncftp license

This printer product includes the open source software program “ncftp-3.2.4” which applies the terms and conditions provided by owner of the copyright to the “ncftp”.

Operating System Versions

In this manual, the following abbreviations are used.

Windows refers to **Windows 8, 7, Vista, XP, Server 2012, Server 2008 R2, Server 2008, and Server 2003.**

- Windows 8 refers to Windows 8, Windows 8 Pro, and Windows 8 Enterprise.
- Windows 7 refers to Windows 7 Home Basic, Windows 7 Home Premium, Windows 7 Professional, Windows 7 Enterprise, and Windows 7 Ultimate.
- Windows Vista refers to Windows Vista Home Basic Edition, Windows Vista Home Premium Edition, Windows Vista Business Edition, Windows Vista Enterprise Edition, and Windows Vista Ultimate Edition.
- Windows XP refers to Windows XP Professional x64 Edition and Windows XP Professional.
- Windows Server 2012 refers to Windows Server 2012 Standard Edition and Windows Server 2012 Essentials Edition.
- Windows Server 2008 R2 refers to Windows Server 2008 R2 Standard Edition and Windows Server 2008 R2 Enterprise Edition.
- Windows Server 2008 refers to Windows Server 2008 Standard Edition and Windows Server 2008 Enterprise Edition.
- Windows Server 2003 refers to Windows Server 2003 Standard Edition and Windows Server 2003 Enterprise Edition.

Index

- A**
- Aligning print head.....101
 - Auto tear-off.....20
- B**
- Barcode printing.....28
 - Bi-D adjustment.....101
 - Buttons.....51
 - Buzzer setting.....35
- C**
- Canceling printing.....47
 - Cleaning
 - print head.....99
 - Cleaning the printer.....103
 - Clients
 - with Windows 8, 7, Vista, XP, Server 2012, Server 2008 R2, Server 2008, or Server 2003.....45
 - Contacting Epson.....64
 - Continuous paper
 - loading.....15
 - removing.....21
 - specifications.....89
 - Control panel.....51, 55
 - buttons.....51
 - lights.....51
 - panel.....51
 - Customer support.....64
- D**
- Driver (printer driver).....26
- E**
- EPSON Status Monitor 3.....26, 32
 - accessing.....34
 - setting up.....32
 - Error indication.....55
- H**
- Head cleaning
 - Windows.....99
- I**
- Ink
 - checking ink cartridge status.....71
 - replacing when expended.....75
 - Ink cartridges
 - part number.....71
- L**
- Labels.....22
 - loading.....22
 - specifications.....89
 - Lights.....51
- M**
- Medicine bag
 - specifications.....89
 - Micro adjust function
 - tear-off position.....23
 - top-of-form position.....24
- N**
- Nozzle check.....97
 - Windows.....97
- P**
- Panel.....51
 - Paper jams.....62
 - Paper specifications.....89
 - Print head
 - aligning.....101
 - checking.....97
 - cleaning.....99

Printer	USB replacement service.....	37
sharing.....		41
Printer driver		
accessing from Windows 8, 7, Vista, XP, Server 2012, Server 2008 R2, Server 2008, or Server 2003.....		27
settings.....		29
settings for Windows 8, 7, Vista, XP, Server 2012, Server 2008 R2, Server 2008, or Server 2003.....		28
uninstalling.....		48
R		
Removing		
continuous paper.....		21
S		
Server		
with Windows 8, 7, Vista, XP, Server 2012, Server 2008 R2, Server 2008, or Server 2003.....		42
Specifications		
character tables.....		94
electrical.....		88
environmental.....		89
mechanical.....		81
paper.....		89
standards and approvals.....		95
Status Monitor 3.....		32
Status sheet.....		102
T		
Tear-off function.....		20
Technical support.....		64
Transporting the printer.....		107
Troubleshooting		
paper jams.....		62
USB problems.....		61
U		
Uninstalling		
printer software.....		48
USB interface		
problems.....		61