

# **Zero Air Generator NGC1500**

**User's manual**

## Content

|   |                                    |    |
|---|------------------------------------|----|
| 1 | Introduction.....                  | 1  |
| 2 | Important safety instruction.....  | 2  |
| 3 | System component.....              | 4  |
| 4 | Engineering design overview.....   | 5  |
| 5 | Installation.....                  | 6  |
| 6 | Operation.....                     | 11 |
| 7 | Maintenance.....                   | 13 |
| 8 | NGC1500 Troubleshooting Guide..... | 17 |
| 9 | Specifications.....                | 18 |

# Introduction

**NOTICE:** This manual is intended to provide technical guidance on the installation, operation and maintenance of the NGC1500 zero air generator. Do not attempt to install or operate this product without having fully read and understood the information presented. If you have questions, please contact your dealer.

**WARNING:** Any misuse of this product will void the manufacturer's warranty.

## 1.1 Product Description

The NGC1500 zero air generator produces laboratory grade purified air for the most accurate and convenient GC-FID equipment. Designed with safety and convenience in mind, this system will generate purified air from an existing in-house oil-free compressed air supply, eliminating the need for inconvenient high-pressure gas cylinders. Eliminating gas cylinders reduces annual operating costs associated with materials, labor, and down-time, and reduces risk of injury to workers.

The NGC1500 zero air generator will remove HC pollutants to less than 0.1 ppm, Operation of the generator requires low levels of air consumption and electrical power. This complete turnkey system is engineered with the highest quality components, is easy to install, and requires only minimal annual maintenance.

## Important safety instruction

When using your zero air generator, basic safety precautions should always be followed, including the following:

1. Read all instructions.
2. Care must be taken as burns can occur from touching hot parts



**WARNING**



**HOT SURFACE INSIDE**



**CONTACT MAY CAUSE BURN**

### **ALLOW TO COOL BEFORE SERVICING**

3. Do not operate equipment with a damaged cord or if the equipment has been dropped or damaged – until it has been examined by a qualified serviceman.
4. Do not let cord hang over edge of table, bench, or counter or come in contact with hot manifolds or moving fan blades.
5. If an extension cord is necessary, a cord with a current rating equal to or more than that of the equipment should be used. Cords rated for less current than the equipment can overheat. Care should be taken to arrange the cord so that it will not be tripped over or pulled.
6. Never use the cord to pull the plug from the outlet. Grasp the plug and pull to disconnect.
7. Let equipment cool completely before putting away. Loop cord loosely around equipment when storing.
8. To reduce the risk of fire, do not operate equipment in the vicinity of open containers of flammable liquids.
9. To reduce the risk of electric shock, do not use on wet surfaces or expose to rain.
10. Use only as described in this manual. Use only manufacturer's recommended attachments.
11. ALWAYS WEAR SAFETY GLASSES when working with this equipment. Everyday eyeglasses have only impact resistant lenses. They are NOT safety glasses.

***SAVE THESE INSTRUCTIONS***

## System component

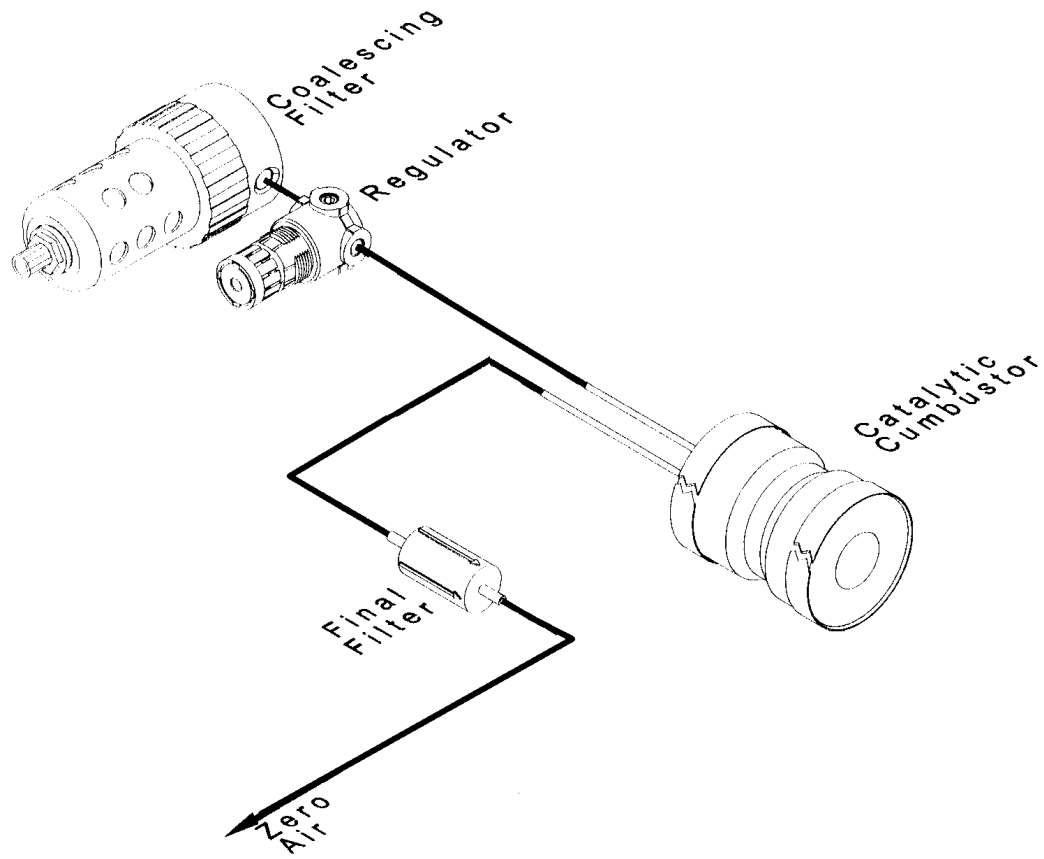

## Engineering design overview

The NGC1500 zero air generator utilizes a 3 stage process to purify ambient air into zero grade air. All main components are manufactured with high grade stainless steel, oriented neatly in cabinet for easy access and service.

### ***Stage 1: Prefiltration and Pressure Regulation***

Air is initially passed through a highly efficient combination coalescing/particulate pre-filter to ensure quality air enters the system. The pre-filter removes bulk moisture and larger particulates greater than 5 microns in size. The filter is supplied with an automatic float drain to remove periodic moisture build up.

The air pressure is then regulated with an adjustable forward pressure regulator, pre-set to 7 bar. The minimum allowable pressure is about 4.5 bar.

### ***Stage 2: Hydrocarbon and CO Removal***

Air is next channeled into a stainless steel catalyst chamber where any background hydrocarbons or carbon monoxide are oxidized. This chamber is filled with a highly efficient platinum catalyst, heated to very high temperatures to insure hydrocarbon removal to less than 0.1 ppm.

### ***Stage 3: Final Filtration***

A final high-grade filter is used to remove 99.99% of particulates greater than 0.5 microns in size. This will insure that no harmful particles will be able to enter your gas analyzers during zero calibration.

### ***Stage 4: Flow regulation***

A flow regulator is used to limit maximum flow rate on the outlet. Calibration can not be changed by users.

## **WARNING!**

**DON'T ADJUST OUTLET FLOW REGULATOR  
ADJUSTMENT OF OUTLET FLOW REGULATOR CAN DAMAGE UNIT  
ANY DAMAGE DONE TO THIS PRODUCT AS A RESULT OF IMPROPER  
MAINTENANCE PROCEDURES WILL VOID THE WARRANTY.**

## Installation

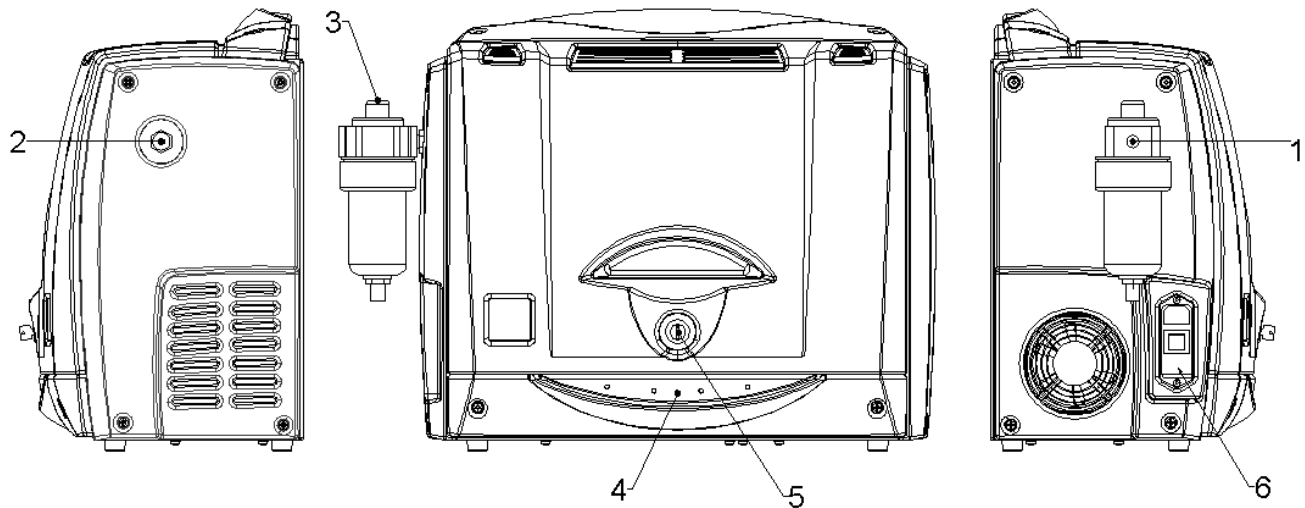

1. Air inlet (1/4 BSP) (Swagelok® p/n SS-400-1-4RT Brass Male Connector, 1/4 in. OD - 1/4 in. Male ISO Tapered Threads)
2. Air outlet (1/8 BSP) (Swagelok® p/n SS-400-1-2RT Brass Male Connector, 1/4 in. OD - 1/8 in. Male ISO Tapered Threads)
3. Inlet air filter
4. Led membrane
5. Door lock
6. Power button

### Items supplied with the unit:

1. Model **NGC1500 zero air generator**, completely assembled and fully burned in, ready for installation;
2. n°1 high quality **inlet air filter assembly** is supplied with each system to remove particulates and bulk moisture before entering your unit;
3. n°1 **power cord**
4. n° 2 **fuses 220VAC**
5. n° 1 **installation kit:**
  - ✓ n°1 male to male adapter to attach your inlet filter to the unit;
  - ✓ n°2 machine screws with matching nuts and split lock washers to mount your unit;
  - ✓ n°2 door keys to lock your unit;
  - ✓ n°1 user manual.

### Items not included with the unit:

1. **Air supply shut-off valve** placed upstream of the unit. This is required for safe and convenient installation and annual maintenance.
2. **Pressure relief valve** installed between the shut-off valve and the inlet of the unit.

NOTE: The inlet air filter assembly supplied with your unit can also be used to de-pressurize your system by de-pressing the pin-valve in the base of the filter housing.

3. **Additional Filtration** may be required depending on the quality of your air supply. The pre-filter of the unit will remove nominal amounts of moisture and particulates. If the air supply has excessive moisture, oil, or particulates, then additional filters should be installed.
4. **1/4" fitting** to install into the supplied pre-filter. The exact type will depend on the supply tubing or hose from air source. A hose clamp is recommended if flexible tubing is used.
5. **1/8" fitting** to install into the bulkhead fitting on the output of your unit. The exact type will depend on the transport tubing or hose to your analyzer. A hose clamp is recommended if flexible tubing is used.



**CAUTION:** *Remove plastic wrap inside unit before applying power.*

### Step 1: Unpack unit and open cover.

- ✓ Remove plastic 1/4" inlet & 1/8" outlet port plugs.

### Step 2: Install 1/4" external inlet filter.

- ✓ Apply Teflon® pipe sealant tape to both sides of the supplied 1/4" male to male adapter.
- ✓ Thread adapter to output side of the air filter assembly. Do not overtighten.
- ✓ Attach Air Filter assembly to input side (left side) of the generator, and secure.

### Step 3: Check voltage setting.

Check the setting of the voltage selector on the side of the unit. The set voltage is indicated by the white arrow. To change the voltage setting, proceed as follows:

- ✓ Using a small screwdriver, remove the voltage selector insert;
- ✓ Replace fuses:



| Voltage setting | Fuse |
|-----------------|------|
| 240 Vac         | 2 AT |
| 120 Vac         | 2 AT |

- ✓ Replace the voltage selector insert so that the white arrow points to the correct voltage.

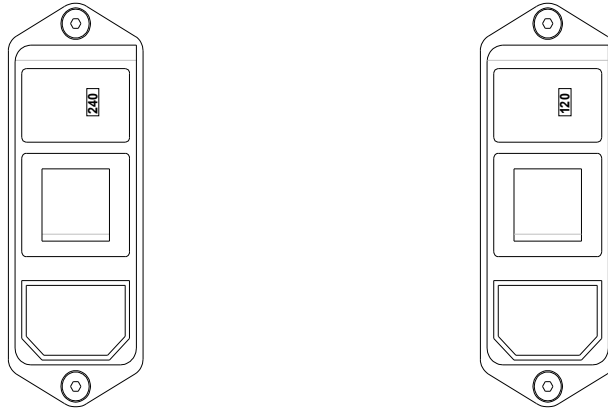

**Step 3: Unit positioning**

There are two different positions that units can be placed:

- a) On a table

Allow at least 15 cm clearance around the sides of the unit for proper ventilation to the unit.

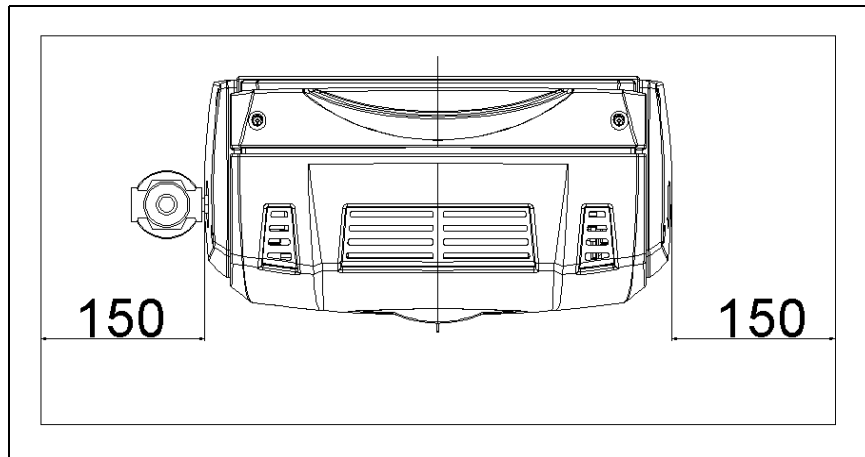

- b) Fixed on a wall or permanent structure

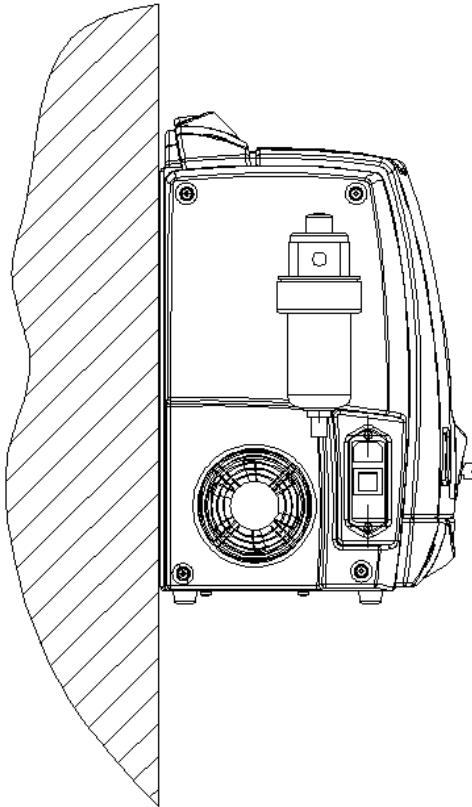

- ✓ Drill appropriate holes in the wall or permanent structure and insert supplied mounting screws. Tighten only enough so there is approximately 1/4" extruding from the surface.

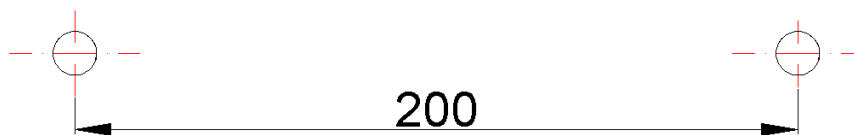

- ✓ Hold the generator up to the extruding screws, and insert the unit over the screws through the keyholes. Let the unit slide downward as the screws slide up into the keyhole slots.

### **WARNING**

**DO NOT TIGHTEN SCREWS FULLY. THE NGC1500 GENERATOR IS NOT DESIGNED TO BE PERMANENTLY MOUNTED TO A WALL OR OTHER PERMANENT STRUCTURE. IT MUST BE POSSIBLE TO REMOVE THE UNIT FROM A PERMANENT STRUCTURE WITHOUT THE USE OF TOOLS.**

### Step 4: Connect Air Supply.

Zero air generator requires a continuous supply of dry, compressed air between 4.5 and 10 bar for proper operation.



#### **WARNING**

**MAXIMUM INLET PRESSURE 10 bar**

5.0.1 The air pressure can be regulated with an adjustable forward pressure regulator, pre-set to 7 bar. The minimum allowable pressure is 4.5 bar.

It is important that the air supply be maintained at room temperature and dew point, and free of oils, hydrocarbons, and particulates. If the compressed air supply for the generator has excess moisture, oil, or particulates, the inlet filter may need premature replacement and the unit may be damaged. Install extra coalescing and particulate filtration upstream from the unit if necessary.



#### **WARNING**

The catalyst chamber can be contaminated by high concentrations of lead, sulfur, phosphorous compounds, heavy metals, chlorinated solvents, and chlorinated hydrocarbons. Extra care should be taken to avoid introducing such compounds to the system.

***Any contamination from oil, water or any of the substances mentioned above will void the warranty on your unit.***

### Step 5: Connect Output.

- ✓ The output bulkhead of the NGC 1500 is located on the right side of the unit. It requires a 1/8" diameter fitting to attach tubing or hose to the gas analyzer zero air port.
- ✓ In order to maintain the purity of the air from your NGC1500, stainless steel tubing or instrument grade Teflon® tubing should be used to connect the generator to the analyzer zero port. Copper tubing can also be used, but should be pre-cleaned or heated with a propane torch while flowing nitrogen through it. All plastic hose should be instrument grade and free of contaminants, so that it will not out-gas any hydrocarbons or other pollutants over time.
- ✓ Maximum outlet flow rate is 1,5 l / pm with 4,5 bar inlet pressure no external restrictions. Actual outlet flow rate will depend on additional system pressure losses, if any.

#### **WARNING**

**Do not use PVC or any other non-instrument grade plastic tubing anywhere in your system. Many plastics will out-gas hydrocarbons and will contaminate your purified air.**



**Step 6: Leak check.**

Before powering the unit, perform a leak check on the external plumbing to the unit.

- ✓ Slowly open supply air valve to pressurize to the system.
- ✓ Apply soapy water to all external fittings and look for air bubbles.
- ✓ Tighten any leaky connections. Additional Teflon® tape may be required in some cases.

## Operation

### Connect power and start unit

Power supply voltage setting follow customer specification.

To start units it is necessary:

- ✓ Insert the female end of the supplied power cord to the power supply connection on the left side of the NGC1500, and plug the male end into a properly grounded socket.
- ✓ Power up the unit using the power switch on the unit.
- ✓ Verify the unit is powered by observing the green led "POWER" on;

| Condition  | Power | Warmup/<br>Check<br>Pressure | Ready | Check<br>System |
|------------|-------|------------------------------|-------|-----------------|
|            | GREEN | YELLOW                       | GREEN | RED             |
| System Off | OFF   | OFF                          | OFF   | OFF             |
| Power up   | ON    | OFF                          | OFF   | OFF             |

## Warming up and normal function

After power-up, the system enters a warm-up cycle.

*It is necessary to wait about 40 min until unit reaches the operative temperature to insure hydrocarbon removal.*

The heater inside catalyst chamber is controlled by an internal thermocouple that will set unit in "ready" mode.

The NGC1500 is designed to run continuously. Continuous operation preserves the life of the catalyst. Shutdown should only be performed for maintenance.

After 40 min verify that:

- ✓ "POWER" green led on;
- ✓ "READY" green led on;

| Condition                | Power<br>led<br>GREEN | Warmup/<br>Check<br>Pressure<br>led<br>YELLOW | Ready<br>led<br>GREEN | Check<br>System<br>led<br>RED |
|--------------------------|-----------------------|---|-----------------------|-------------------------------|
| Warm-up (40 minutes)     | ON                    | OFF   | OFF                   | OFF                           |
| Ready (after 40 minutes) | ON                    | OFF   | ON                    | OFF                           |

## Shutdown Procedure

Before performing any service or maintenance to the NGC1500 zero air generator, be sure to complete the following steps:

- ✓ Turn off power using the switch of the unit.
- ✓ Disconnect the outlet tubing, and freely run air through the unit for several minutes to cool the catalyst. Allow a minimum of 2 hours to cool the catalyst before replacing.
- ✓ Shut off air supply.
- ✓ De-pressurize the unit and disconnect power source before servicing.

## Maintenance



**WARNING:**

Before service is performed, make certain that the following conditions are met:

1. System shut down has been performed according to instructions above.
2. Supply pressure has been shut off with an in-line valve.
3. Line pressure has been released with an in-line relief valve.
4. Unit has been shut-off and isolated from electrical power.

### Annual Maintenance Kits

The NGC1500 zero air generator is designed to operate continuously for an entire year before service is required. An annual maintenance kit will be available as spare part. This kit will include all required parts. Specifically, each kit will include:

1. New pre-filter element.
2. New high-grade particulate final filtration.

### 3-year Catalyst Replacement Kits

A catalyst kit will also be available as spare part for its 3 year replacement. The catalyst must be replaced every 3 years to insure the removal of CO and HC to 0.1 ppm levels.



**WARNING**

**ONLY QUALIFIED PERSONNEL SHOULD PERFORM SERVICE ON THIS PRODUCT. ANY DAMAGE DONE TO THIS PRODUCT AS A RESULT OF IMPROPER MAINTENANCE PROCEDURES WILL VOID THE WARRANTY.**

### 1. Annual Pre-filter Element Replacement:

- ✓ Remove the filter bowl (fig. 1, pos.1) pressing on the lever and turning the bowl counter-clockwise until the arrow are aligned;
- ✓ Unscrew the filter element base and remove element(fig.1, pos 3) .

Insert the new element from your annual maintenance kit and reassemble the filter in reverse order.

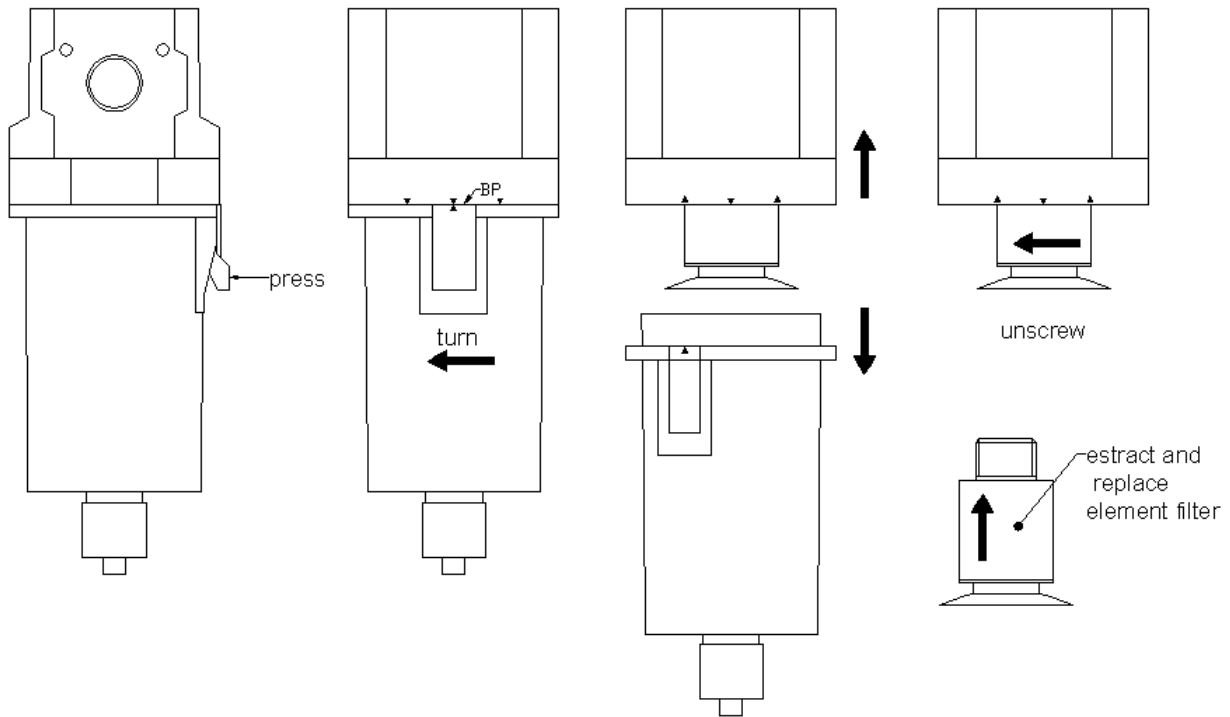

fig. 1: Pre-filter disassembling for element filter replacement.

**NOTE:** More frequent replacement of the inlet filter may be required depending on the quality of the air supply in the garage. Alternately, more filtration can be applied upstream of the GC 1500.

## 2. Annual High Grade In-line Particulate Filter Replacement:

The high grade in-line particulate filter is the final component before the outlet.

The filter body is clear plastic and is held by inlet and outlet plastic air lines.

- ✓ Disconnect the filter(1) from the push-in connector(2) of the air line;
- ✓ Replace the used filter with the new one. Make certain the flow direction indicated on the filter housing points in the “downward” direction, toward the outlet pressure regulator on the unit.

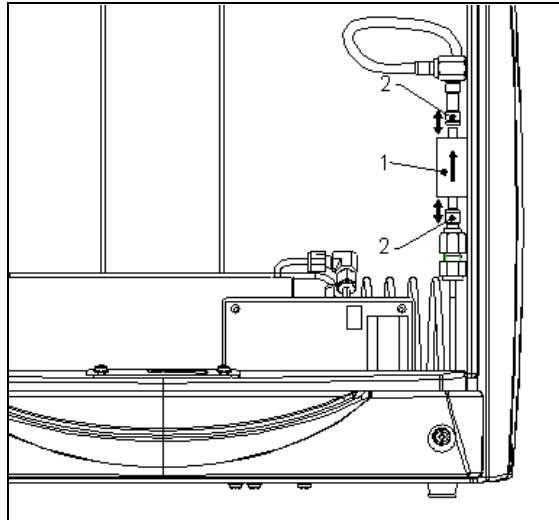

### 3. Three Year Catalyst Chamber Replacement:

The catalyst chamber used in the NGC1500 should be replaced every 3 years to maintain carbon monoxide and hydrocarbon specification. The system should be shut down as described above prior to replacement. Allow the unit to cool for a minimum of 2 hours before replacement.

- ✓ If unit has been powered recently and catalyst is hot, turn off the power. DO NOT turn off the air at this time.
- ✓ Remove the outlet connection and allow the outlet air to flow freely for 2 hours to cool the catalyst. After 2 hours of cool-down, disconnect the air supply. Depressurize the system by depressing the pin at the bottom of the inlet filter housing.
- ✓ Open front panel with door key;
- ✓ Untighten screws 1 and 2 and remove the right side plastic cover removing screws 3;

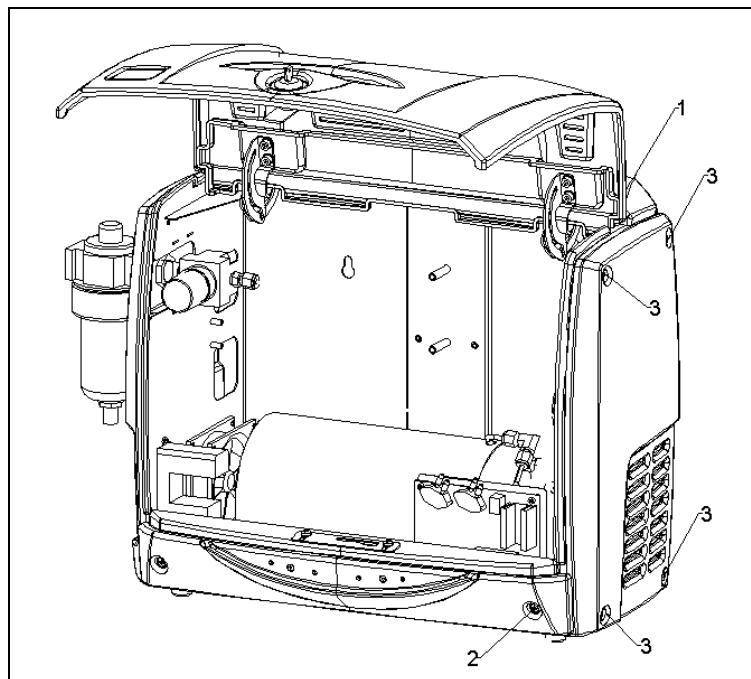



- ✓ Carefully disconnect the two compression air fittings 1 and 2 to disconnect the cooling spiral 3 from oven;

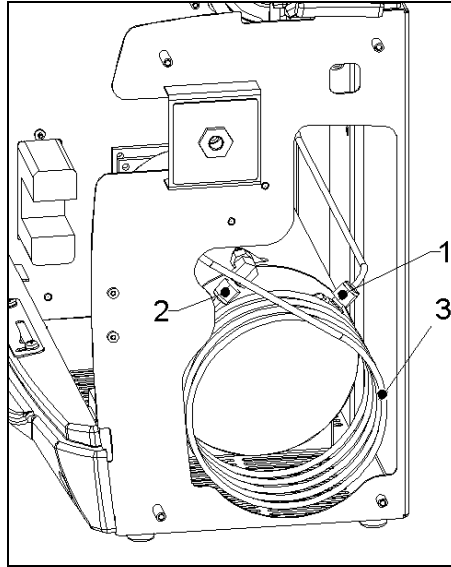

- ✓ Remove heater and thermocouple wire's from control board and GND wire from oven;
- ✓ When the catalyst chamber is cool to the touch, remove the four screws connecting catalyst chamber assembly to main chassis;
- ✓ Extract catalyst chamber assembly from unit;
- ✓ Install the new catalyst chamber assembly using the reverse process;
- ✓ Pressurize the system and check thoroughly for leaks.

## NGC1500 Troubleshooting Guide

### 1. Green led "POWER" off.

- Verify power cord connection;
- Verify you are using proper fuses for power supply voltage setting.

### 2. Red led "CHECK SYSTEM" on.

Red led on led membrane have to turn on only when a failure occur to internal heater and thermocouple reads a value higher than the maximum allowed of 704°C (1300 °F). In this case power supply to heater is stopped.

- Turn off and on unit to reset to initial status.

If the problem cannot be solved with these step, return the unit to your local distributor.

### 3. Leaks .

- Apply soapy water to all external fittings and look for air bubbles;

- ❑ Tighten any leaky connections. Additional Teflon® tape may be required in some cases.

## Specifications

|  |                 |
|--|-----------------|
| Outlet Zero Air                              | 1500 ml/min     |
| Outlet Hydrocarbon Concentration             | < 0.1 ppm       |
| Outlet Carbon Monoxide Concentration         | < 0.1 ppm       |
| Outlet Particles < 0.5 microns removed       | 99.99%          |
| Outlet Air Temperature                       | Ambient + 15 °C |
| Max Inlet Hydrocarbon Concentration          | 100 ppm         |
| Max Inlet Carbon Monoxide Concentration      | 50 ppm          |
| Max Inlet Temperature                        | 40 °C           |
| Inlet Pressure Range (regulated to 7 bar)    | 4.5 - 10 bar    |
| Pressure Drop @ max. Flow Rate               | 1 bar           |
| Maximum Outlet Pressure                      | 6 bar           |
| Maximum continuous output flowrate           | 1.5 std l/min   |
| Startup Time for Specified THC Concentration | 40 minutes      |
| Inlet Port                                   | 1/4"            |
| Outlet Port                                  | 1/8"            |

## Zero Air Generator NGC1500 User's Manual

---

|                             |                 |
|-----------------------------|-----------------|
| Electrical Requirements     | 115/230VAC      |
| Power consumption           | 160 VA          |
| Operating temperature range | (15 ± 40)°C     |
| Relative Humidity           | (0 ± 80)%       |
| Index of protection         | IP2X            |
| System Dimensions (HxWxD)   | 41 x 47 x 25 cm |
| Generator Weight            | 8 kg            |
| Shipping Weight             | 12 kg           |