

X1 TOTAL -BODY ELLIPTICAL CROSS-TRAINER

Owner's Manual

8973601 REV B-3



LifeFitness
WHAT WE LIVE FOR

CORPORATE HEADQUARTERS

5100 River Road
Schiller Park, Illinois 60176 • U.S.A.
847.288.3300 • FAX: 847.288.3703
Service phone number: 800.351.3737 (toll-free within U.S.A., Canada)
800.351.3737 (Service phone number, toll-free within U.S.A., Canada)
Global Website: www.lifefitness.com

INTERNATIONAL OFFICES

AMERICAS

North America Life Fitness Inc.

5100 N River Road
Schiller Park, IL 60176 U.S.A
Telephone: (847) 288 3300
Fax: (847) 288 3703
Service Telephone: (800) 351 3737
Service Email: customersupport@lifefitness.com
Sales/Marketing Email:
consumerproducts@lifefitness.com
Operating Hours: 7:00 am-6:00 pm (CST)

Brazil Life Fitness Brasil

Av. Cidade Jardim, 900
Jd. Paulistano
São Paulo, SP 01454-000
BRAZIL
SAC: 0800 773 8282
Telephone: +55 (11) 3095 5200
Fax: +55 (11) 3095 5201
Service Email: suporte@lifefitness.com.br
Sales/Marketing Email: lifefitness@lifefitness.com.br
Service Operating Hours:
9:00 - 17:00 (BRT) (Monday-Friday)
Store Operating Hours:
9:00 -20:00 (BRT) (Monday-Friday)
10:00 - 16:00 (BRT) (Saturday)

Latin America & Caribbean* Life Fitness Inc.

5100 N River Road
Schiller Park, IL 60176 U.S.A
Telephone: (847) 288 3300
Fax: (847) 288 3703
Service Email: customersupport@lifefitness.com
Sales/Marketing Email: commercialsales@lifefitness.com
Operating Hours: 7:00am-6:00pm (CST)

EUROPE, MIDDLE EAST, & AFRICA (EMEA)

Netherlands & Luxemburg Life Fitness Atlantic BV

Bijdorplein 25-31
2992 LB Barendrecht
THE NETHERLANDS
Telephone: (+31) 180 646 666
Fax: (+31) 180 646 699
Service Email: service.benelux@lifefitness.com
Sales/Marketing Email:
marketing.benelux@lifefitness.com
Operating Hours: 9.00h-17.00h (CET)

United Kingdom & Ireland Life Fitness UK LTD

Queen Adelaide
Ely, Cambs, CB7 4UB
Telephone: General Office (+44) 1353.666017
Customer Support (+44) 1353.665507
Fax: (+44) 1353.666018
Service Email: uk.support@lifefitness.com
Sales/Marketing Email: life@lifefitness.com
Operating Hours:
General Office: 9.00am - 5.00pm (GMT)
Customer Support: 8.30am - 5.00pm (GMT)

Germany & Switzerland Life Fitness Europe GMBH

Siemensstraße 3
85716 Unterschleißheim
GERMANY
Telephone: (+49) 89.31 77 51.0 (Germany)
(+41) 0848 000 901 (Switzerland)
Fax: (+49) 89.31 77 51.99 (Germany)
(+41) 043 818 07 20 (Switzerland)
Service Email: kundendienst@lifefitness.com
Sales/Marketing Email: kundenberatung@lifefitness.com
Operating Hours: 08.30 -16.30h (CET)

Austria Life Fitness Austria

Vertriebs G.m.b.H.
Dückerstraße 7-9/3/36
1220 Vienna
AUSTRIA
Telephone: (+43) 1.61.57.198
Fax: (+43) 1.61.57.198.20
Service Email: kundendienst@lifefitness.com
Marketing/Sales Email: kundenberatung@lifefitness.com
Operating Hours: 08:30-16:30.h (MEZ)

Spain Life Fitness IBERIA

C/Frederic Mompou 5,1ª^a
08960 Sant Just Desvern Barcelona
SPAIN
Telephone: (+34) 93.672.4660
Fax: (+34) 93.672.4670
Service Email: info.iberia@lifefitness.com
Sales/Marketing Email: info.iberia@lifefitness.com
Operating Hours:
9.00h-18.00h (Monday-Thursday)
8.30h-15.00h (Friday)

Belgium Life Fitness Benelux NV

Parc Industriel de Petit-Rechain
4800 Verviers
BELGIUM
Telephone: (+32) 87 300 942
Fax: (+32) 87 300 943
Service Email: service.benelux@lifefitness.com
Sales/Marketing Email:
marketing.benelux@lifefitness.com
Operating Hours: 9.00h -17.00h (CET)

Italy Life Fitness Europe GmbH

Siemensstraße 3
85716 Unterschleißheim
GERMANY
Telephone: (+39) 02-55378611
Service: 800438836 (In Italy)
Fax: (+39) 02-55378699
Service Email: assistentatecnica@lifefitness.com
Sales/Marketing Email: info@lifefitnessitalia.com
Operating Hours: 08:30 - 16:30h (CET)

All Other EMEA countries & Distributor Business C-EMEA*

Bijdorplein 25-31
2992 LB Barendrecht
THE NETHERLANDS
Telephone: (+31) 180 646 644
Fax: (+31) 180 646 699
Service Email: service.db.cemea@lifefitness.com
Sales/Marketing Email:
marketing.db.cemea@lifefitness.com
Operating Hours: 9.00h-17.00h (CET)

ASIA PACIFIC (AP)

Japan Life Fitness Japan

Nippon Brunswick Bldg., #8F
5-27-7 Sendagaya
Shibuya-Ku, Tokyo
Japan 151-0051
Telephone: (+81) 3.3359.4309
Fax: (+81) 3.3359.4307
Service Email: service@lifefitnessjapan.com
Sales/Marketing Email: sales@lifefitnessjapan.com
Operating Hours: 9.00h-17.00h (JAPAN)

China and Hong Kong Life Fitness Asia Pacific LTD

Room 2610, Miramar Tower
132 Nathan Road
Tsimshatsui, Kowloon
HONG KONG
Telephone: (+852) 2891.6677
Fax: (+852) 2575.6001
Service Email: HongKongEnquiry@lifefitness.com
Sales/Marketing Email: ChinaEnquiry@lifefitness.com
Operating Hours: 9.00h-18.00h

All Other Asia Pacific countries & distributor business Asia Pacific*

Room 2610, Miramar Tower
132 Nathan Road
Tsimshatsui, Kowloon
HONG KONG
Telephone: (+852) 2891.6677
Fax: (+852) 2575.6001
Service Email: HongKongEnquiry@lifefitness.com
Sales/Marketing Email: ChinaEnquiry@lifefitness.com
Operating Hours: 9.00h-18.00h

Thank you for purchasing a Life Fitness Total-Body Elliptical Cross-Trainer. Before using this product, please read this owner's manual in its entirety to ensure that you have the knowledge to safely and properly operate all of the features of your Total-Body Elliptical Cross-Trainer. We hope you achieve the product experience that you expect, but if you do have any service issues, please go to the How to Obtain Product Service section which will provide information on obtaining product service.

FCC Warning - Possible Radio / Television Interference

Note: *This equipment has been tested and found to comply with the limits for a Class B digital device, pursuant to part 15 of the FCC rules. These limits are designed to provide reasonable protection against harmful interference in a residential installation. This equipment generates, uses and can radiate radio frequency energy, and if not installed and used in accordance with the user manual, may cause harmful interference to radio communications. However, there is no guarantee that the interference will not occur in a particular installation. If this equipment does cause harmful interference to radio or television reception, which can be determined by turning the equipment off and on, the user is encouraged to try to correct the interference by one or more of the following measures:*

- Reorient or relocate the receiving antenna.
- Increase the separation between the equipment and the receiver.
- Connect the equipment into an outlet on a circuit different from that to which the receiver is connected.
- Consult the dealer or an experienced radio/TV technician for help.

Class HB (Home): Domestic use.



CAUTION: Any changes or modifications to this equipment could void the product warranty.

Any service, other than cleaning or user maintenance, must be performed by an authorized service representative. There are no user-serviceable parts.

TABLE OF CONTENTS

1.	Important Safety Instructions	.5
2.	X1 Total Body Elliptical Cross-Trainer Overview	.7
3.	Assembly	.8
3.1	Tools & Hardware	.8
3.2	Packaging	.9
3.3	Assemble the Stabilizer	.9
3.4	Assemble the Console Upright	.9
3.5	Connect Base Wiring	.9
3.6	Assemble the Rocker Arms	.10
3.7	Assemble Moving Arms to Pedal Arms	.11
3.8	Assemble Front Base Cover; Console Bracket to the Upright	.12
3.9	Connect all Console Wiring; Console to Console Bracket; Back Plastic Shell	.13
3.10	Plug in the Unit	.13
4.	Initial Setup	.14
5.	Service and Product Maintenance	.16
5.1	Troubleshooting	.16
5.2.	Preventative Maintenance Tips	.18
5.3	How to Obtain Product Service	.18
6.	Specifications	.19
7.	Warranty Information	.20

© 2011 Life Fitness, a division of Brunswick Corporation. All rights reserved.

This Operation Manual describes the functions of the following product:

Life Fitness Cross-Trainer Model:

X1

Statement of Purpose: The Life Fitness Total-Body Elliptical Cross-Trainer is an exercise machine that combines low-impact elliptical pedaling, where resistance is independent of speed, with push/pull arm motion to provide an efficient, effective total body workout.



CAUTION: Health-related injuries may result from incorrect or excessive use of exercise equipment. The manufacturer **STRONGLY** recommends seeing a physician for a complete medical exam before undertaking an exercise program, particularly if the user has a family history of high blood pressure or heart disease; or is over the age of 45; or smokes, has high cholesterol, is obese, or has not exercised regularly in the past year. The manufacturer also recommends consulting a fitness professional on the correct use of this product.

If, at any time while exercising, the user experiences faintness, dizziness, pain, or shortness of breath, he or she must stop immediately.

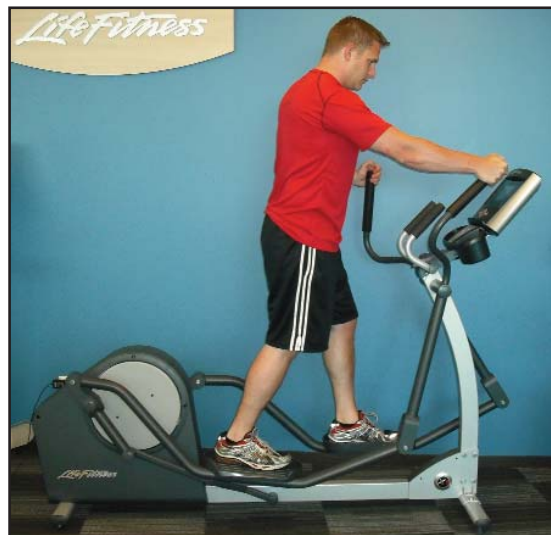

1 IMPORTANT SAFETY INSTRUCTIONS

WARNING: Read all instructions before using the Total-Body Elliptical Cross-Trainer. Save these Instructions.

WARNING: Heart rate monitoring systems may be inaccurate. Over exercising may result in serious injury or death.

WARNING: Any adjustment devices that could interfere with the user's movement should not be left projecting.

DANGER: To reduce the risk of electrical shock, always unplug this Life Fitness product before cleaning or attempting any maintenance activity.



SAFETY WARNING: The safety of the product can be maintained only if it is examined regularly for damage and wear. See Preventive Maintenance section for details.



The heart rate hand pulse sensors provide an approximate heart rate value. The sensors are not medical devices and should not be used in any type of medical application.

- Before using this product, it is essential to read this ENTIRE operation manual and ALL instructions. The Total-Body Elliptical Cross-Trainer is intended for use solely in the manner described in this manual.
- Always follow the console instructions for proper operation.
- This appliance is not intended for use by persons (including children) with reduced physical, sensory or mental capabilities, or lack of experience and knowledge, unless they have been given supervision or instruction concerning use of the appliance by a person responsible for their safety.
- Children should be supervised to ensure that they do not play with the appliance.
- Never insert objects into any openings in this product. If an object should drop inside, turn off the power, unplug the power cord from the outlet and carefully retrieve it. If the item cannot be reached, contact Life Fitness Customer Support Services.
- Never place liquids of any type directly on the unit, except in an accessory tray. Containers with lids are recommended.
- Do not use the Total-Body Elliptical Cross-Trainer outdoors, near swimming pools or in areas of high humidity.
- Keep all loose clothing, shoelaces, and towels away from the Total-Body Elliptical Cross-Trainer pedals.
- Keep the area around the Total-Body Elliptical Cross-Trainer clear of any obstructions, including walls and furniture.
- Use caution when mounting or dismounting the Total-Body Elliptical Cross-Trainer. While exercising, always hold onto the user arms or stationary handlebar.
- Never operate a Life Fitness product if it has been dropped, damaged, or even partially immersed in water. Contact Life Fitness Customer Support Services.
- Keep the power cord away from heated surfaces. Do not pull the equipment by the power cord or use the power cord as a handle.
- Do not run the power cord on the floor under or along side of the Total-Body Elliptical Cross-Trainer.
- Wear shoes with rubber or high-traction soles. Do not use shoes with heels, leather soles, cleats or spikes. Do not use the Total-Body Elliptical Cross-Trainer in bare feet.
- Do not tip the Total-Body Elliptical Cross-Trainer on its side during operation.
- Keep hands and feet away from all moving parts.
- To ensure proper functioning of this product, do not install attachments or accessories that are not provided or recommended by Life Fitness.
- Use this product in a well-ventilated area.
- Use this product on a solid, level surface.
- Make sure that all components are fastened securely.
- An appliance should never be left unattended when plugged in. Unplug from outlet when not in use, and before putting on or taking off parts.

- Do not operate under blanket or pillow. Excessive heating can occur and cause fire, electric shock, or injury to persons.
- Never operate this appliance if it has a damaged cord or plug, if it is not working properly, if it has been dropped or damaged, or dropped into water. Contact Life Fitness Customer Support Services.
- Never operate the appliance with the air openings blocked. Keep the air openings free of lint, hair, and the like.
- To disconnect, turn all controls to the off position, then remove plug from outlet.
- Allow LCD consoles to “normalize” with respect to temperature for one hour before plugging the unit in and/or using.

SAVE THESE INSTRUCTIONS FOR HOUSEHOLD USE.

2 X1 TOTAL-BODY ELLIPTICAL CROSS-TRAINER OVERVIEW

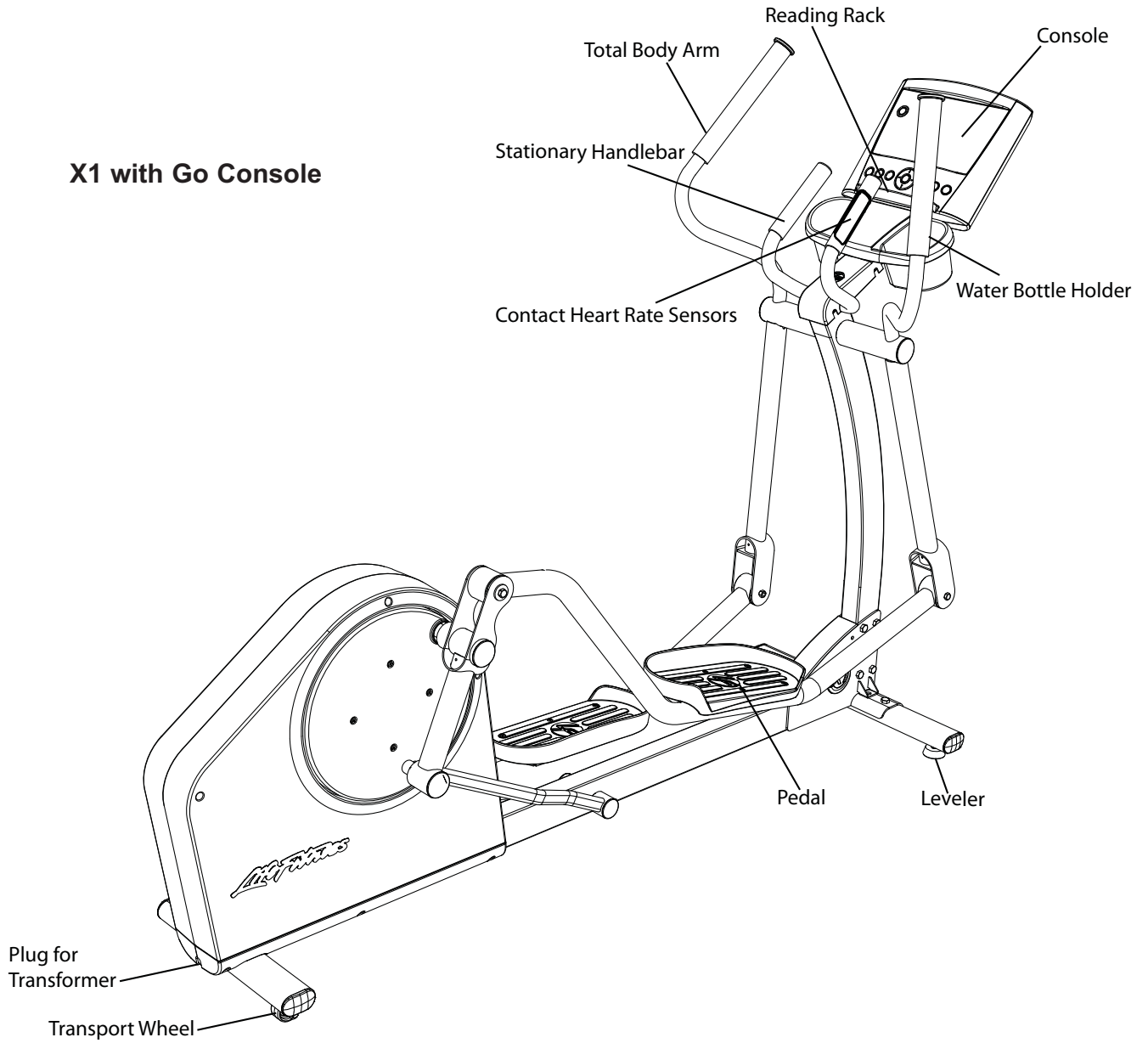

3 ASSEMBLY

3.1 TOOLS & HARDWARE

Identify the following components after unpacking your cross-trainer:

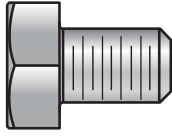
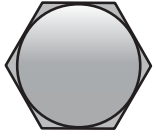

M10 X 15MM SILVER HEX HEAD BOLT (QTY. 4)

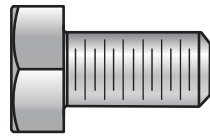
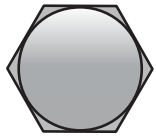

M10 X 20MM CLEAR ZINC HEX HEAD BOLT (QTY. 3)

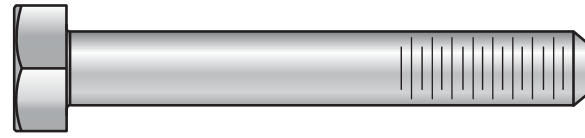
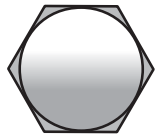

M10 X 70MM SILVER HEX HEAD BOLT (QTY. 3)

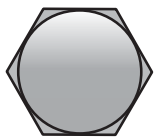

M10 X 74MM BLACK HEX HEAD BOLT (QTY. 2)

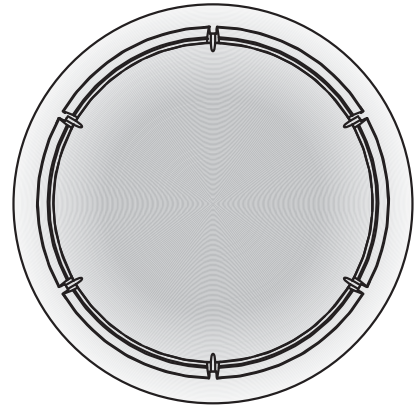

PLASTIC END CAP (QTY. 2)

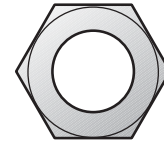

M10 HEX NUT (QTY. 2)

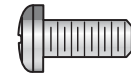

M5 X 12MM CLEAR ZINC PHILLIPS HEAD SCREW (QTY. 4)

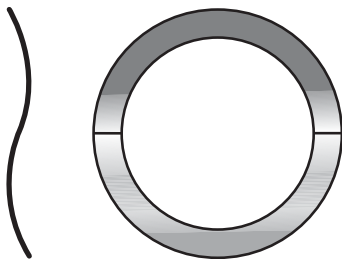

WAVE WASHER (QTY.2)

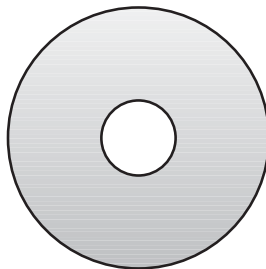

FLAT WASHER 10mm ID (QTY. 2)

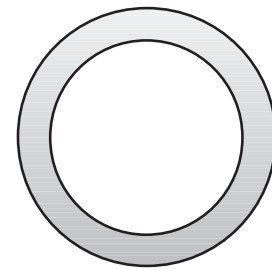

LARGE FLAT WASHER (QTY. 2)

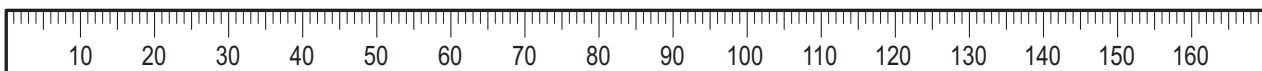

Tools Needed for Assembly:

- Phillips Head Screwdriver
- 17mm Socket Wrench
- 17mm Open End Wrench

3.2 PACKAGING

Parts: None

Remove all packaging and place main components to the side of the box. Break box down in each of the four corners.

3.3 ASSEMBLE THE STABILIZER

Parts: Hardware Bag #1 (2, M10 X 15mm Silver Hex Head Bolts)

Tools: 17mm Socket Wrench

Assemble the stabilizer tube (foot) (A) to the bottom base bracket (B) of the product using two M10 X 15mm Silver Hex Head Bolts (C).

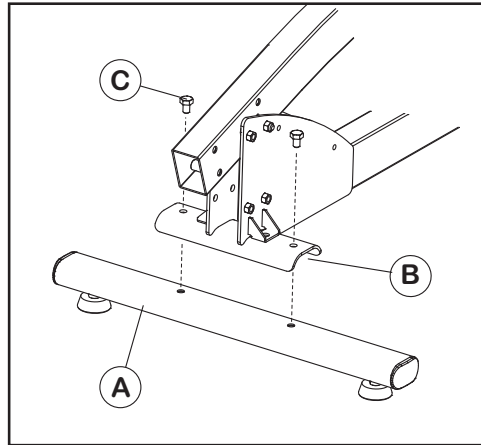

3.4 ASSEMBLE THE CONSOLE UPRIGHT

Parts: Hardware Bag #2 (3, M10 X 70mm Long Silver Hex Head Bolts)
(1, M10 X 20mm Clear Zinc Hex Head Bolt)

Tools: 17mm Socket Wrench

The console upright tube (D) is pre-assembled with one bolt so that you can simply lift the upright into place by pivoting upward. Hold the upright in place and install three M10 X 70mm Long Silver Hex Head Bolts (E) into the side of the main bracket (F). Install one M10 X 20mm Clear Zinc Hex Head Bolt (G) into the front of the bracket.

CAUTION: Do not pinch wires when assembling the upright.

3.5 CONNECT BASE WIRING

Parts: None

Connect the two plugs (H) at the base of the upright.

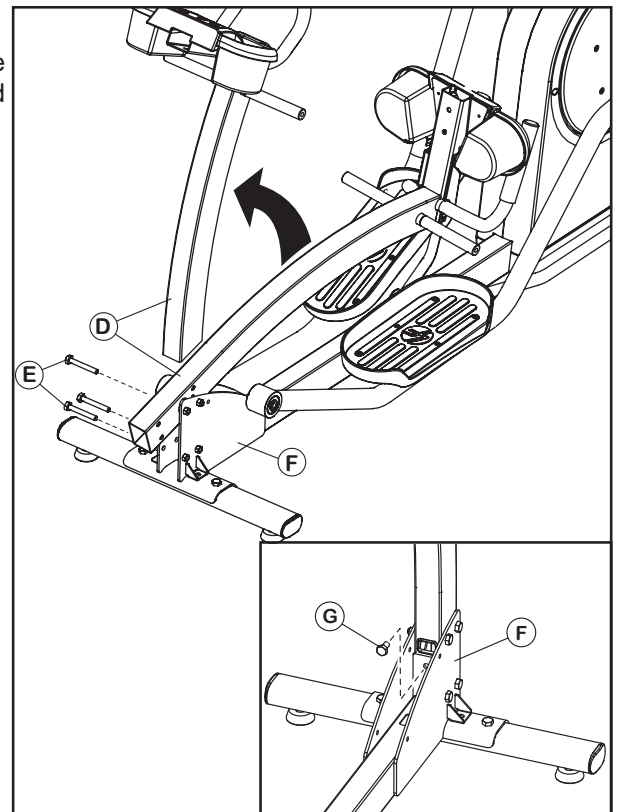
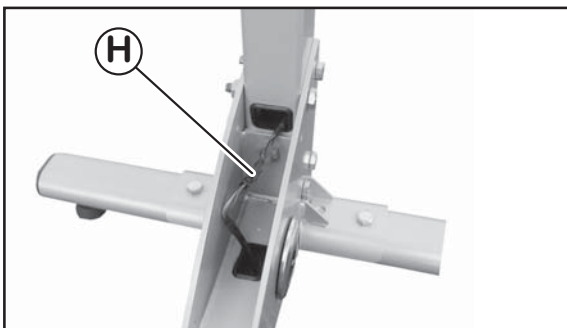

3.6 ASSEMBLE THE ROCKER ARMS

Parts: Hardware Bag #3 (2, Wave Washers, 2 Large Flat Washers)
(2, Flat Washers)
(2, M10 X 20mm Hex Head Bolts)
(2, Plastic End Caps)

Tools: 17mm Socket Wrench, Phillips Screwdriver, Rubber Mallet

Slide one large Flat Washer (I) and one Wave Washer (J) onto the user right pivot shaft (K). Slide the washers fully over the pivot shaft until seated against the pre-installed stop ring (L).

Locate the user right rocker arm assembly (M) marked with an "R". With the top handgrip facing the front of the unit, slide the right rocker arm assembly onto the user right pivot shaft until seated against the washers.

Secure the rocker arm assembly to the pivot shaft using one Flat Washer (N) and one M10 X 20mm Hex Head Bolt (O). Tighten the bolt securely. Repeat the procedure for the left rocker arm assembly.

Use a rubber mallet to tap the round end of the Plastic End Caps (P) into the side of the rocker arms.

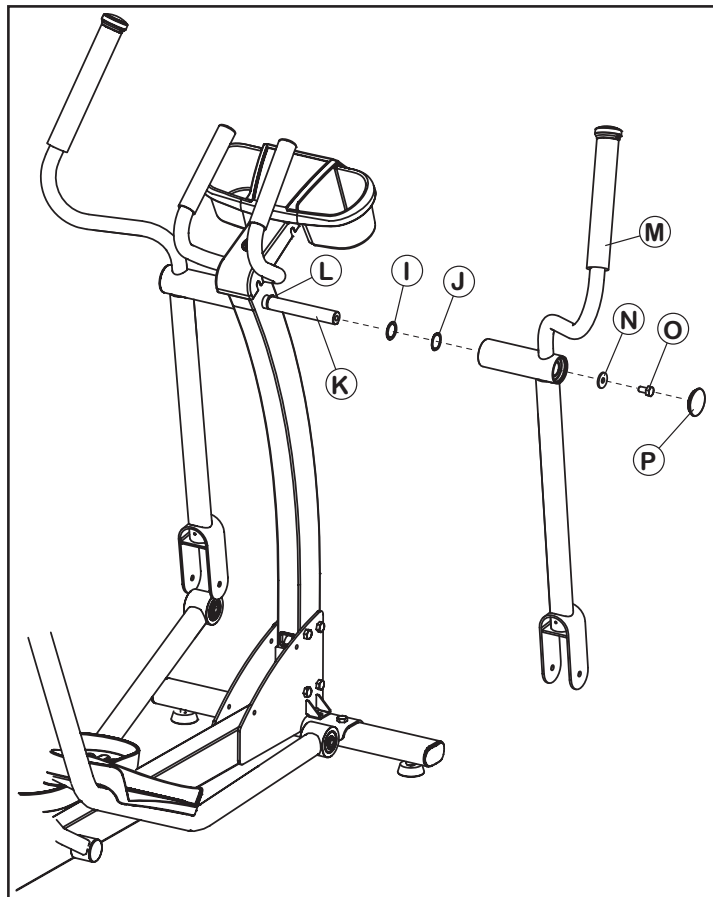

3.7 ASSEMBLE MOVING ARMS TO PEDAL ARMS

Parts: Hardware Bag #4 (2, M10 X 74mm Black Hex Head Bolts)
(2, M10 Hex Nuts)

Tools: 17mm Socket Wrench, Phillips Screwdriver

Lift the front end of the user left pedal lever (Q) to meet the left rocker arm clevis (R). Secure the pedal lever to the rocker arm clevis using one M10 X 74mm Black Hex Head Bolts (S) and one M10 Hex Nut (T). Tighten the bolt and nut securely. Repeat the procedure for the right pedal lever and rocker arm clevis.

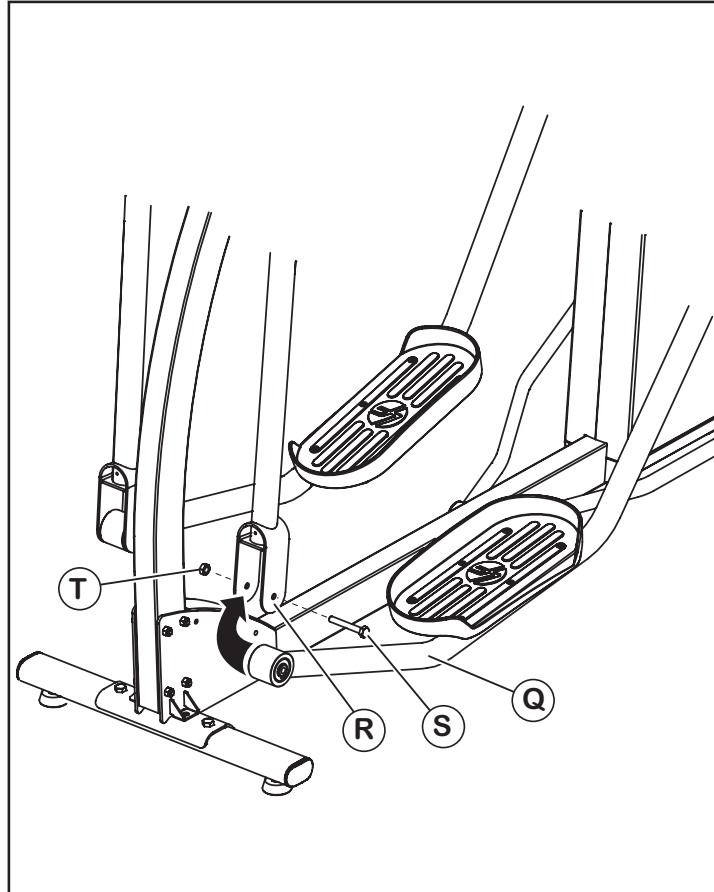

3.8 ASSEMBLE FRONT BASE COVER; CONSOLE BRACKET TO THE UPRIGHT

Parts: Hardware Bag #5 (2, M10 X 15mm Silver Hex Head Bolts)

Tools: Phillips Screwdriver, 17mm Socket Wrench

Position the front base cover (U) over the main bracket (V). Align the four tabs on the front base cover with the four hole on the main bracket. Snap into place.

Slide the console bracket (W) into the upright. Use two M10 X 15mm Silver Hex Head Bolts (X) to attach the console bracket to the upright (Y).

Note: Avoid pinching the console wires.

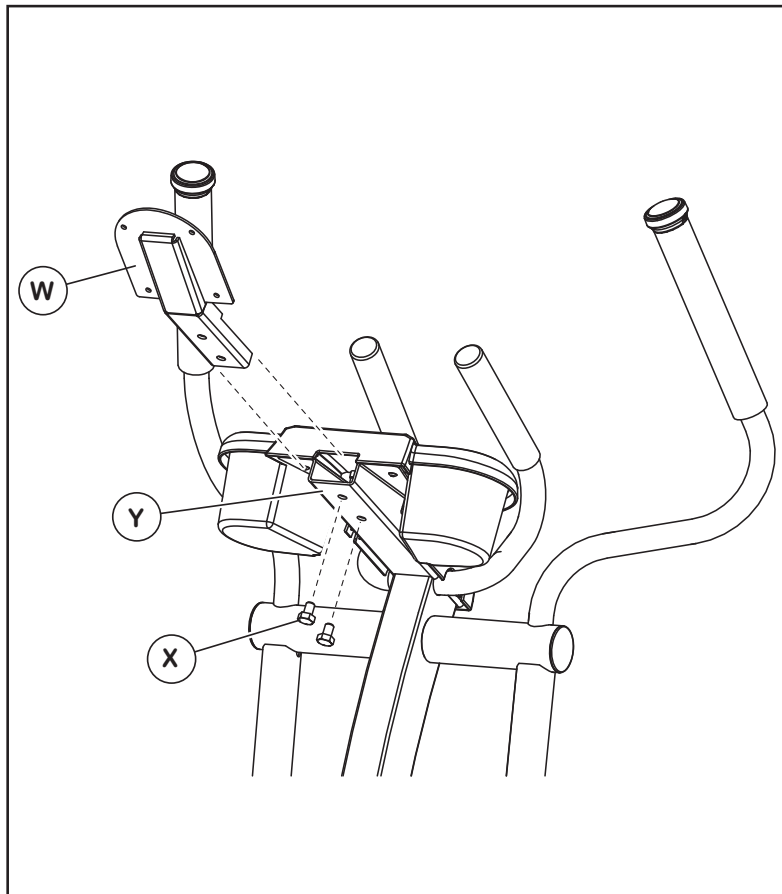
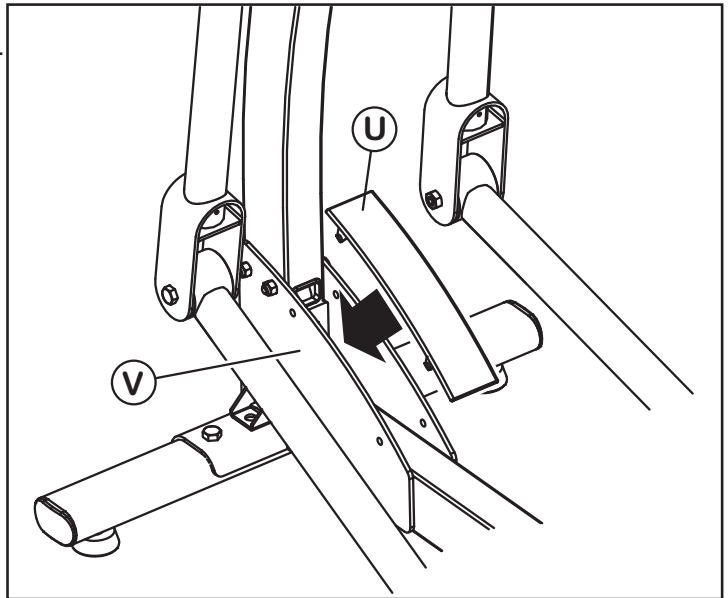

3.9 CONNECT ALL CONSOLE WIRING; CONSOLE TO CONSOLE BRACKET; BACK PLASTIC SHELL

Parts: Hardware Bag #6 (4, M5 X 12mm Silver Phillips Screws)

Tools: Phillips Screwdriver

Position the console (Z) close to the console bracket (W) and follow the below instructions to connect all wiring.

Plug cables into the back of the display console:

1. Plug the 15-pin connector at the end of the upper wire harness into the 15-pin connector (15P) in the back of the display console. Make sure the connector snaps into place.
2. Plug the 4-pin connector at the end of the contact heart rate sensor cable to the 4-pin cable (4P) located in the console.
3. Plug the ground cable (green wire, single spade) from the product base to any of the three metal ground terminals (G) in the Go Console, or into the connector (G) leading from the back of the Track Console.
4. Push excess cables into the opening of the upright tube assembly.

Line up the four holes in the console bracket with the four holes in the back of the display console. Attach the display console using four M5 X 12mm Silver Phillips Screws (A). Be careful not to pinch cables between the console and the console bracket. Be sure to get each screw started before fully tightening.

Note: To avoid stripping, do not overtighten the screws.

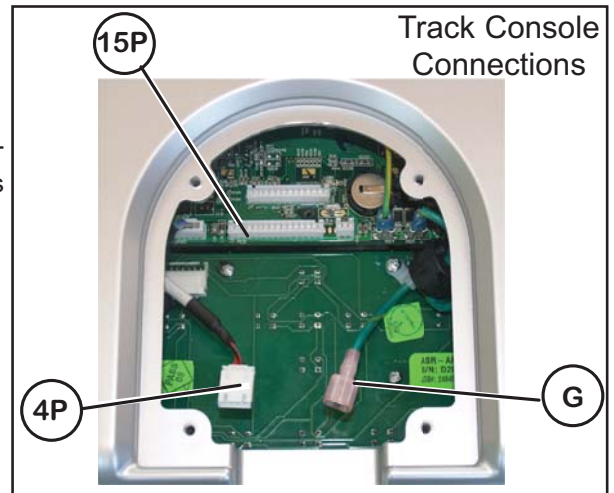
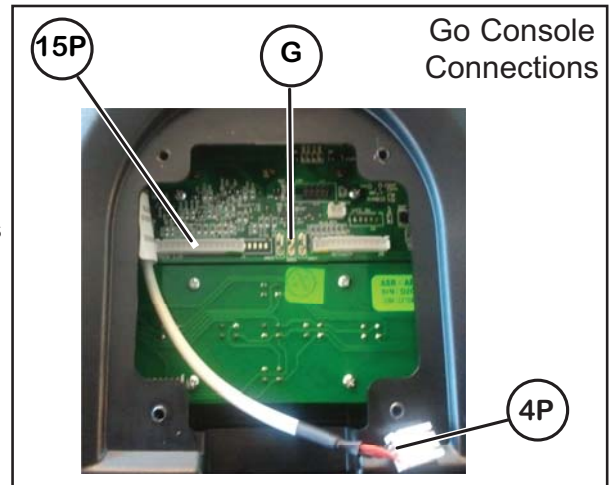
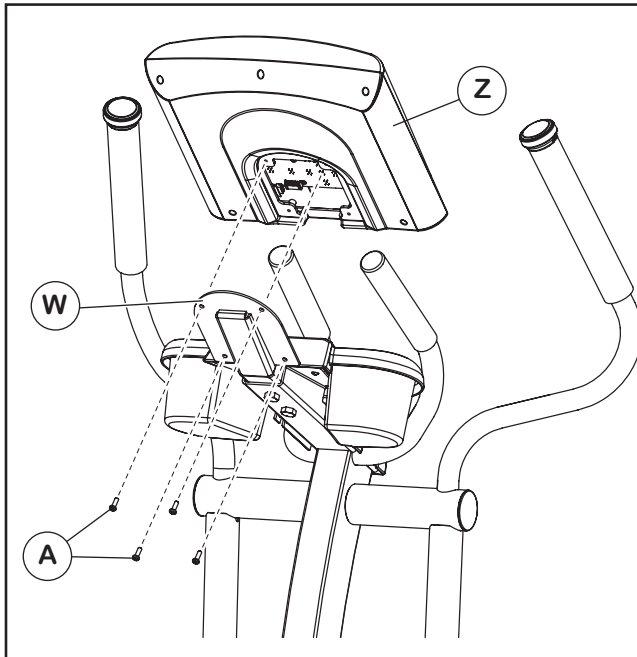

3.10 PLUG IN THE UNIT

Parts: Electric Transformer

Plug the black cord into the back of the machine and into a household electrical outlet.

4 INITIAL SETUP

Read the entire User Manual before setting up the Total-Body Elliptical Cross-Trainer.

Note: This Total Body Elliptical Cross-Trainer is speed independent. Resistance can be adjusted by means other than speed.

WHERE TO PLACE THE TOTAL-BODY ELLIPTICAL CROSS-TRAINER

After following all safety instructions move the Total-Body Elliptical Cross-Trainer to the place where it will be used. Allow a minimum clearance of 12 inches (30.5 cm) around the product. See specifications for full dimensions if needed. The Total-Body Elliptical Cross-Trainer is equipped with rear wheels so that it is simple to push or pull the Total-Body Elliptical Cross-Trainer to its final destination. Simply lift the front of the Total-Body Elliptical Cross-Trainer to move. Once the Total-Body Elliptical Cross-Trainer is properly positioned, allow enough space in the front of the Total-Body Elliptical Cross-Trainer for the movement of the pedal levers. Also be sure to allow space on the side so that it is easy to mount the Total-Body Elliptical Cross-Trainer from the side.

CAUTION: Make certain you have plenty of room for the swing of the moving arms.

CAUTION: Place the Total-Body Elliptical Cross-Trainer in a dry place. Do not place in highly humid areas, like near swimming pools, as rust and corrosion may occur.

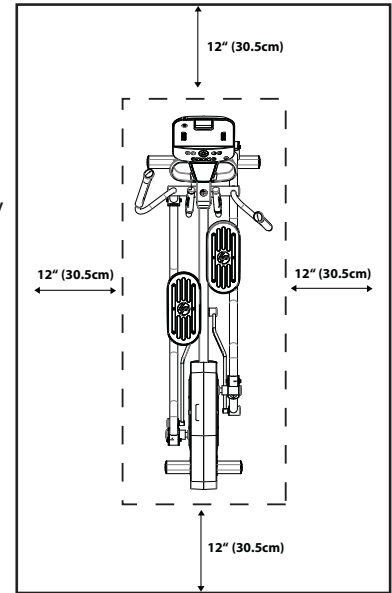

HOW TO STABILIZE THE TOTAL-BODY ELLIPTICAL CROSS-TRAINER

Once the cross trainer is positioned in the room adjust the levelers on the front stabilizer. The levelers will keep the Total-Body Elliptical Cross-Trainer fixed to the floor while using it.

CAUTION: Do not use the Total-Body Elliptical Cross-Trainer without the levelers touching the floor.

After placing the Total-Body Elliptical Cross-Trainer where it will be used, check the stability. If there is even a slight rocking motion, or the unit is not stable, the levelers will need to be adjusted. Determine which leveler is not resting firmly on the floor. To adjust the levelers downward twist the rubber portion of the leg counterclockwise. To adjust the levelers upward twist the rubber portion of the leg clockwise. Be sure there is a minimum of 5 mm (0.20 in.) of thread showing between the leveler and the leveler locking nut.

Note: After the Cross-Trainer is level, be sure to tighten the nut on the leveler against the stabilizer tube. If this is not tightened, noise will occur.

POWERING UP THE TOTAL-BODY ELLIPTICAL CROSS-TRAINER

Your Life Fitness Total-Body Elliptical Cross-Trainer may come with either a U.S. power supply or one of several international power supplies. Insert the appropriate power adapter jack into the connector (A) on the back of the Total-Body Elliptical Cross-Trainer. Then insert the plug into the wall outlet. Make sure the cord is placed so it doesn't bind and will not be walked on. Then check that the console lights up. If not, recheck the plug and the wall connections and make sure the wall outlet has power.

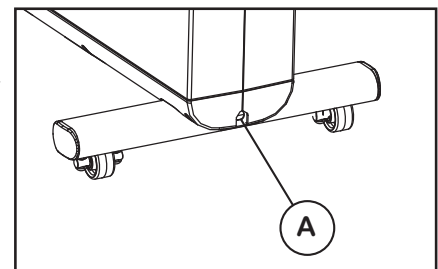

MOUNTING THE MACHINE

When mounting the machine it is recommended that the pedal closest to you is in its lowest position. This can be done by pushing the arms to rotate the pedal until it is centered to the side of you at its lowest position. If you are standing to the left side of the machine, when facing the console, place your left foot on the pedal closest to you and then swing your right leg over to the right pedal. Use the stationary handlebar to stabilize yourself.

DISMOUNTING THE MACHINE

Bring the machine to a stop. It is recommended to put the pedal in its lowest position on the side of the unit you will be dismounting. If dismounting the machine on the left side, when facing the console, step off with the right leg first followed by the left leg. Use the stationary handlebar for stabilization.

CONTACT HEART RATE

The X1 includes hand pulse sensors on the stationary handlebar that are a built-in heart rate monitoring system. During a workout grasp the hand pulse sensors to monitor your heart rate. We recommend using the heart rate chest strap provided with your console during workouts and using the hand pulse sensors to only occasionally monitor your heart rate when not using the chest strap. In addition, to utilize heart rate controlled workouts the chest strap must be used. For the most accurate reading, use a comfortable grip. The console will show a heart rate reading after 15 to 20 seconds.

Hand pulse sensors can work differently with different body types. With some individuals it can be very difficult to extract a heart rate reading. Follow the tips below to improve the heart rate reading:

- Remove your hands from the heart rate sensors and wait for the heart rate display to clear. Grasp sensors again.
- Make sure hands are fully contacting the sensors.
- Dry hands periodically during use.
- Limit movement.
- Clean hand pulse sensors.

Note: *The heart rate hand pulse sensors provide an approximate heart rate value. The sensors are not medical devices and should not be used in any type of medical application.*

5 SERVICE & PRODUCT MAINTENANCE

5.1 TROUBLESHOOTING

Problem	Cause / Solution
No power.	Check to see that the power cord is fully plugged into the back of the Total-Body Elliptical Cross-Trainer and into the wall. Make sure the power cord is fully seated into the back of the Total-Body Elliptical Cross-Trainer.
	You may be in "Energy Saver Mode". Press the "Energy Saver" button to see if the console turns on.
	Verify that all customer assembly connections are working properly. Unplug and re-plug each connection to verify. Look to see if any cables were pinched during assembly.
Total Body Arms feel loose.	Remove the moving arm pivot covers and check to make certain the bolt holding the total body arm in place is fully tightened. If the total body arms still feel loose, you may want to disassemble the total body arms and make sure all of the proper hardware from the assembly instructions was used.
Noise is coming from pedals.	Some noise from the pedals is normal. It will vary depending on the weight of the user. Check assembly hardware beneath pedal to make certain it is tight.
Hear noise as speed increases.	It is normal for any mechanical device to become louder as speed increases.
Start-Up resistance seems very difficult.	Your product may be in 'Safety Mode'. Refer to the console manual on how to turn off this setting
	Turn the unit off and then on again.
Can't feel a resistance change at the beginning levels.	The resistance curve of the Total-Body Elliptical Cross-Trainer is designed so that you can feel a greater difference in resistance at higher levels.
Wireless heart rate is not working.	<p>Potential reasons for the wireless heart rate not to work properly include:</p> <ol style="list-style-type: none"> 1. The wireless heart rate is turned OFF in the Settings Menu. Enter the Settings Menu and verify that WIRELESS HR is turned ON. 2. There is poor contact between the telemetry heart rate strap and the skin. 3. There is electrical interference from electrical appliances with the telemetry heart rate strap from fluorescent lights, kitchen appliances, etc. Move the Total-Body Elliptical Cross-Trainer to a different location or move electrical appliances away from the Total-Body Elliptical Cross-Trainer. 4. The battery in the Heart Rate Telemetry Strap needs to be replaced. The battery is a CR2032 (3V).

Problem	Cause / Solution
Creaking sound is coming from the stabilizers.	It is very important that the nut on the leveler is tightened against the stabilizer tube after the product is leveled. Ensure that this nut is tight.
"OFF" is displayed in the LEVEL window on the console.	Turn the unit off and then on again.
	If power cycling the product did not work, there is a problem with the resistance system. Contact customer service for assistance.
The contact heart rate sensors are not reading my heart rate correctly.	Be sure to grasp the sensors firmly and keep hands still. If heart rate seems substantially higher or lower than expected, remove hands from sensors until heart rate disappears.
	<p>Tips for contact heart rate:</p> <ol style="list-style-type: none"> 1. Dry hands to prevent slipping on the sensors. 2. Apply hands to all four sensors (two in each hand). 3. Grasp sensors firmly. 4. Apply constant pressure to the sensors. 5. May need to wait longer for heart rate to display. <p>Note: The heart rate hand pulse sensors provide an approximate heart rate value. The sensors are not medical devices and should not be used in any type of medical application.</p>
iPod is not recognized. Note: Applies to Track Console only.	This is displayed if your version of the iPod Player is not supported by the cross-trainer. It may also be displayed if the connector on the cross-trainer or iPod is damaged.
iPod is not charging while in Energy Saver mode. Note: Applies to Track Console only.	Your iPod will not charge if the cross-trainer enters Energy Saver mode. This is normal.
"Low Battery" message is displayed on the console. Note: Applies to Track Console only.	The console has an internal battery that keeps the real time clock functioning if the cross-trainer is unplugged. This real time clock is only needed if you use the Life Fitness "Virtual Trainer" website. You do not need to replace the battery if you do not use the website. Contact Customer Service for guidance on how to change the battery. The battery is a CR1632 (3V).
When I try to save a workout on the USB stick I receive the following message: UNABLE TO SAVE SEE MANUAL. Note: Applies to Track Console only.	<p>The console may not have recognized the USB stick. Try unplugging the USB stick and plugging it back in.</p> <p>The USB stick may be full.</p> <p>The USB stick may not be compatible with the product.</p> <p>Try using a different USB stick.</p>

5.2 PREVENTATIVE MAINTENANCE TIPS

The Life Fitness Total Body Elliptical Cross-Trainer is backed by the engineering excellence and reliability of Life Fitness and is one of the most rugged and trouble-free pieces of exercise equipment on the market today.

Note: Safety of the equipment can be maintained only if the equipment is examined regularly for damage or wear. Keep the equipment out of use until the defective parts are required or replaced. Pay special attention to parts that are subject to wear, as outlined below.

The following preventative maintenance tips will keep the Life Fitness Total Body Elliptical Cross-Trainer operating at Peak performance:

Important: Turn the cross-trainer off and unplug prior to performing any maintenance.	
Weekly	Inspect the power cord. If the cord is damaged call technical support. Make sure the cord is positioned in a location where it will not be damaged.
Monthly	Clean the top surface of the pedals.
	Clean the display console and all exterior surfaces with mild soap, water and a soft cotton cloth or a Life Fitness approved cleaner. Note: Do not use paper towels, ammonia or acid based cleaners on the product. At no time should cleaner be applied directly to any part of the equipment; spray the cleaner on a soft cloth and then wipe the unit.
	Inspect the exterior parts for wear and check that user assembly bolts are still tight.

Note: Long fingernails may damage or scratch the surface of the console. Use the pad of the finger to press the keys.

LIFE FITNESS APPROVED CLEANERS

Two preferred cleaners have been approved by Life Fitness reliability experts: PureGreen 24 and Gym Wipes. Both cleaners will safely and effectively remove dirt, grime and sweat from equipment. PureGreen 24 and the Antibacterial Force formula of Gym Wipes are both disinfectants that are effective against MRSA and H1N1.

PureGreen 24 is available in a convenient spray. Apply the spray to a microfiber cloth and wipe down the equipment. Use PureGreen 24 on the equipment for at least 2 minutes for general disinfection purposes and at least 10 minutes for fungus and viral control.

Gym Wipes are large, durable pre-moistened wipes to use on the equipment before and after workouts. Use Gym Wipes on the equipment for at least 2 minutes for general disinfection purposes.

Contact Life Fitness Customer Support Services to order these cleaners.
Call 1-800-351-3737 or email: customersupport@lifefitness.com.

LIFE FITNESS COMPATIBLE CLEANERS

Mild soap and water or a mild non-abrasive household cleaner can also be used to clean the display and all exterior surfaces. Use a soft cotton cloth only. Apply the cleaner to the cotton cloth before cleaning. DO NOT use ammonia or acid based cleaners. DO NOT use abrasive cleaners. DO NOT use paper towels. DO NOT apply cleaners directly to the equipment surfaces.

5.3 HOW TO OBTAIN PRODUCT SERVICE

1. Please contact your dealer or Life Fitness Customer Service at 1-800-351-3737.
2. Verify the symptom and review the operating instructions and troubleshooting matrix.
3. Locate and document the serial number of the unit. The serial number plate is located on the main frame in front of the rear shrouds. Please also have proof of purchase information available.

6 SPECIFICATIONS

LIFE FITNESS X1 CROSS-TRAINER SPECIFICATIONS

Designed Use:	Home
Max User Weight:	350 lbs / 159 kilograms
Max Step-Up Height:	6.5 inches / 16.5 centimeters
Resistance System:	Eddy Current
Stride Length:	20 inches
Power Supply:	120 Volt (U.S.), 220 Volt (Europe), 240+ Volt (Australia)

ASSEMBLED/ WORKING DIMENSIONS:

Length	81 inches / 206 centimeters
Width	30 inches / 76 centimeters
Height	59 inches / 150 centimeters
Weight	215 pounds / 98 kilograms

SHIPPING DIMENSIONS:

Length	81 inches / 206 centimeters
Width	21 inches / 51 centimeters
Height	32 inches / 81 centimeters
Weight	242 pounds / 110 kilograms

7 WARRANTY INFORMATION

Model	Limited Lifetime	3 Years	1 Year
X1 Cross-Trainer Base	Frame	Electrical Parts & Mechanical Parts	Labor

WHAT IS COVERED:

This Life Fitness consumer product ("Product") is warranted to be free of all defects in material and workmanship.

WHO IS COVERED:

The original purchaser or any person receiving a newly purchased Product as a gift from the original purchaser. Warranty will be voided on subsequent transfers.

HOW LONG IS IT COVERED:

Residential: All electrical and mechanical components and labor are covered, after the date of purchase, as listed on the chart above.

Non-Residential: Warranty void (this Product is intended for residential use only).

WHO PAYS SHIPPING & INSURANCE FOR SERVICE:

If the Product or any warranted part must be returned to a service facility for repairs, Life Fitness will pay all shipping and insurance charges during the warranty period (within the United States only). The purchaser is responsible for shipping and insurance charges after the warranty has expired.

WHAT WE WILL DO TO CORRECT COVERED DEFECTS:

We will ship to you any new or rebuilt replacement part or component, or, at our option, replace the Product. Such replacement parts are warranted for the remaining portion of the original warranty period.

WHAT IS NOT COVERED:

Any failures or damage caused by unauthorized service, misuse, accident, negligence, improper assembly or installation, debris resulting from any construction activities in the Product's environment, rust or corrosion as a result of the Product's location, alterations or modifications without our written authorization or by failure on your part to use, operate and maintain the Product as set out in your User Manual ("Manual"). All terms of this warranty are void if this Product is moved beyond the continental borders of the United States of America (excluding Alaska, Hawaii and Canada) and are then subject to the terms provided by that country's local authorized Life Fitness Representative.

WHAT YOU MUST DO:

Retain proof of purchase. Use, operate and maintain the Product as specified in the Manual; notify the place of purchase of any defect within 10 days after discovery of the defect; if instructed, return any defective part for replacement or, if necessary, the entire Product for repair. Life Fitness reserves the right to decide whether or not a product is to be returned for repair.

USER MANUAL:

It is VERY IMPORTANT THAT YOU READ THE MANUAL before operating the Product. Remember to perform the periodic maintenance requirements specified in the Manual to assure proper operation and your continued satisfaction.

PRODUCT REGISTRATION:

Register online at www.lifefitness.com/home/product-registration.html. Our receipt assures that your name, address and date of purchase are on file as a registered owner of the Product. Being a registered owner assures coverage in the event you lose your proof of purchase. Please retain your proof of purchase, such as your bill of sale or receipt.

HOW TO GET PARTS & SERVICE:

Refer to page one of this manual for your local service contact information. Reference your name, address and the serial number of your Product (consoles and frames may have separate serial numbers). They will tell you how to get a replacement part, or, if necessary, arrange for service where your Product is located.

EXCLUSIVE WARRANTY:

THIS LIMITED WARRANTY IS IN LIEU OF ALL OTHER WARRANTIES OF ANY KIND EITHER EXPRESSED OR IMPLIED, INCLUDING BUT NOT LIMITED TO THE IMPLIED WARRANTIES OF MERCHANTABILITY AND FITNESS FOR A PARTICULAR PURPOSE, AND ALL OTHER OBLIGATIONS OR LIABILITIES ON OUR PART. We neither assume nor authorize any person to assure for us any other obligation or liability concerning the sale of this Product. Under no circumstances shall we be liable under this warranty, or otherwise, of any damage to any person or property, including any lost profits or lost savings, for any special, indirect, secondary, incidental or consequential damages of any nature arising out of the use of or inability to use this Product. Some states do not allow the exclusion or limitation of implied warranties or of liability for incidental or consequential damages, so the above limitations or exclusions may not apply to you. Warranties may vary outside the U.S. Contact Life Fitness for details.

CHANGES IN WARRANTY NOT AUTHORIZED:

No one is authorized to change, modify or extend the terms of this limited warranty.

EFFECT OF U.S. STATE LAWS:

This warranty gives you specific legal rights and you may have other rights which vary from state to state.