

USER'S MANUAL
Model: *ITC-18/PCI*
DATA ACQUISITION
INTERFACE

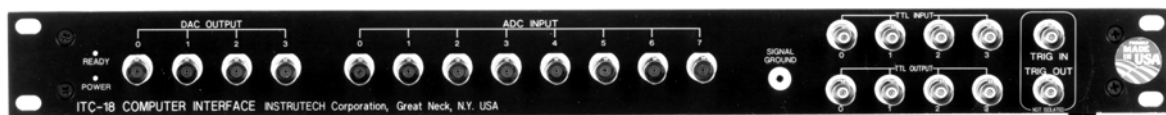

InstruTECH

Precision Instrumentation for Biological Research

20 Vanderventer Avenue, Suite 101E
Port Washington, New York 11050-3752 U. S. A.
Tel: (516) 883-1300 Fax: (516) 883-1558
Internet: sales@instrutech.com
support@instrutech.com
<http://www.instrutech.com/>

Table of Contents

Table of Contents	2
Table of Figures	3
Credits	4
1 General Information	5
1.1 Product intended usage	5
1.2 Accessories.....	5
1.3 Unpacking	5
1.4 Purchase Information	7
1.5 Technical Specifications	8
1.6 Description	9
1.7 Explanation of symbols.....	12
2 Controls and Functions	13
2.1 Front Panel Controls	13
2.2 Rear Panel Controls	15
3 Installation.....	18
3.1 Hardware installation	18
4 Important considerations.....	20
4.1 Warm up.....	20
4.2 Differential analog to digital inputs	20
5 Troubleshooting	21
6 Additional Software	22
6.1 Available Driver Software	22
6.2 Igor XOP's	22
7 Product Upgrades.....	23
7.1 PCI-18 adaptability	23
8 Product Registration.....	24
8.1 Why Register your purchase?	24
8.2 How to Register your purchase.....	24
8.3 Product announcement mailing list.....	24
9 Rear Panel Connector PIN Assignments	25
9.1 VR-10/100 Digital Data Recorder Connector.....	25
9.2 Serial I/O Connector	26
9.3 Current Driver Out Connector	26
9.4 Digital I/O and Sequence Out Connector	27
9.5 Auxiliary Output Connector.....	28
10 Warranty Information.....	29
10.1 Limited Warranty	29
10.2 Obtaining Warranty Service.....	29

Table of Figures

FIGURE 1. EXPLANATION OF SYMBOLS	12
FIGURE 2: ITC-18 FRONT PANEL CONTROLS	13
FIGURE 3: ITC-18 REAR PANEL CONTROLS	15
FIGURE 4: ITC-18 CURRENT DRIVER OUT EXTERNAL CONNECTIONS.....	16
FIGURE 5: ITC-18 VR-10/VR-100 CONNECTOR PINS	25
FIGURE 6: ITC-18 SERIAL PORT CONNECTOR PINS	26
FIGURE 7: ITC-18 CURRENT DRIVER OUT CONNECTOR PINS	26
FIGURE 8: ITC-18 DIGITAL I/O AND SEQUENCER OUT CONNECTOR PINS.....	27
FIGURE 9: ITC-18 AUXILIARY OUTPUT CONNECTOR PINS.....	28

Credits

Instrutech Corporation would like to thank the following individuals who have contributed their time and ideas to the development and testing of the *ITC-18* computer interface:

Dr. Fred Sigworth, Yale University

Dan Brown, Bruxton Corporation

Dr. Hubert Affolter, Heka elektronik

1 General Information

1.1 Product intended usage

The Instrutech *ITC-18/PCI* is intended for research use only in a laboratory by persons trained in its use. Users are expected to be able to properly operate the *ITC-18/PCI* and associated instruments.

The Instrutech *ITC-18/PCI* is not intended for medical use. The Instrutech *ITC-18/PCI* is not intended for use in life support situations, or in situations where improper operation or failure of the *ITC-18/PCI* can result in personal injury.

Instrutech Corporation makes no representation that the design, implementation, testing, or manufacture of the *ITC-18/PCI* meet reasonable standards for use as a medical product.

As stated in the Instrutech Limited Warranty Statement, supplied with each product, "Instrutech Corporation expressly disclaims all warranties to buyer except the limited warranty set forth above, including without limitation to any and all implied warranties of merchantability and fitness for a particular purpose."

1.2 Accessories

The following items should have been packed with your *ITC-18/PCI Computer Interface*:

- 1 Power cord, 110 volt or 220 volt type depending on application
- 1 *ITC-18* Computer interface
- 1 *PCI-18* PCI Bus computer plug in card
- 1 Cable assembly
- 1 *ITC-18* Warranty card
- 1 *PCI-18* Warranty card
- 1 User's manual

If any of these items are missing please contact Instrutech Corporation immediately.

1.3 Unpacking

After unpacking the *ITC-18* and accessories from the shipping carton, please inspect each piece for any signs of shipping damage. Please contact the delivering carrier and Instrutech Corporation immediately if there is any damage. Do not dispose of the shipping carton. The carrier will want to examine the shipping carton to process a damage claim. Instrutech Corporation insures all shipments to cover shipping damage. It is also advisable to keep the shipping carton in the event that the instrument must be returned for service.

Use caution when removing the *PCI-18* computer plug-in card from the special static shielding bag that it is packed in. This board is susceptible to damage and degradation by static discharges. Do not remove the board from this static protection until you are ready to install it into the computer. Touch the computer chassis to equalize the static charge between yourself and the computer chassis before handling the computer board. *Following these steps is extremely important to prevent damage to the computer interface card.* Instrutech Corporation does not warranty the *PCI-18* computer card from damage caused by improper handling.

1.5 Technical Specifications

Unless otherwise noted ambient temperature = 25 degrees Celsius

◆ Analog Input Channels:

Channels:	8
Input Range:	-10.24 volts to +10.23 volts
Gain:	High-speed programmable gain (1, 2, 5, or 10X) instrumentation amplifier
Settling time:	3 microseconds (0.01% all gains)
Input Type:	True Differential
Conversion Speed:	Programmable, 5 μ s (200 kHz) to 82 ms (12 Hz) in 1.25 μ s steps
Resolution:	16 bit, 1 in 3200
Input impedance:	1 Meg ohm
Input connector:	BNC
Absolute maximum input:	\pm 40 volts peak

◆ Analog Output Channels:

Channels:	4 with built-in thermal stabilization
Output Range:	-10.24 volts to 10.23 volts
Output Type:	Pseudo-differential
Conversion Speed:	Programmable from 5 μ s (200 kHz) to 82 ms (12 Hz) in 1.25 μ s steps
Resolution:	True 16 bit
Settling Time:	Less than 4 us to 0.001%
Current drive capability:	20 milliamperes typical
Output impedance:	200 ohm
Output connector:	BNC

◆ Digital I/O Channels:

TTL Inputs: Sixteen CMOS compatible input lines with programmable sense level (HIGH or LOW). Two modes of operation: latched or level sensing. The latched mode will hold the value until read by the software. Level sensing will change with all level transitions. Either mode requires an input signal with a minimum duration of 150 nanoseconds. Four inputs are available through BNC connectors on the front panel. All inputs are available through a rear panel multi-pin connector. The absolute maximum voltage range for these inputs is -0.5 volts to +5.5 volts. *Do not exceed this range or damage can result to the input circuitry.*

TTL Outputs: Two banks (channels) with sixteen CMOS compatible output lines each. Will drive AC, HC, ACT, HCT or a maximum of eight TTL loads. Four outputs from channel 1 are available through BNC connectors on the front panel. All outputs are available through a rear panel multi-pin connector and internal connectors.

Driven Outputs: Fourteen current outputs (parallel with channel 1 output lines) divided into two user banks. Each bank of 7 outputs can sink 350 milliamperes maximum depending on number of outputs in use. An external power source is required. Available on a female DB-25 connector on rear panel.

Trigger In:	Start acquisition from an external unisolated CMOS compatible source. Available through a BNC connector on the front panel. . The absolute maximum voltage range for this input is -0.5 volts to +5.5 volts. <i>Do not exceed this range or damage can result to the input circuitry.</i>
Trigger Out:	Unisolated programmable trigger output. Available through a BNC connector on the front panel.
Sequencer Out:	Seven isolated programmable CMOS compatible trigger outputs. The sequencer outputs are very precise triggers that can be programmed to toggle when a particular entry in the sequence RAM is executed. Available through a multi-pin connector on rear panel.

◆ **PCI-18 Host interface:**

The *PCI-18* PCI interface card is a 5 volt, slave PCI host card that interfaces the ITC-18 rack unit to the host computer.

The *PCI-18* card is compatible with version 2.0 of the PCI bus specification.

◆ **FIFO memory:**

Standard: 1024 kilosample FIFO

◆ **External Clock:**

Optional 12.8 megahertz external clock will synchronize multiple ITC-18 interfaces.

◆ **Dimensions:**

W: 19", H: 1.75", D: 10.5", Weight: 8 pounds

W: 47.5 cm, H: 4.375 cm, D: 26.25 cm, Weight: 3.6 kg

◆ **Power requirements:**

85-264VAC 47-440 Hz 15 Watts.

◆ **Warranty:**

Two years parts and labor.

All technical specifications are nominal conditions and are subject to change without notice.

1.6 Description

The ITC-18 is the second generation computer interface from Instrutech Corporation. The ITC-18 offers increased capability while retaining all of the exceptional features of its predecessor, the ITC-16. The ITC-18 advances data acquisition to a new level!

Hardware Configuration:

The ITC-18 is a rack-mountable unit. It has BNC connectors for the analog inputs and outputs and ribbon-cable connectors for the digital lines.

The ITC-18 is connected to a host computer over a shielded cable to a host interface card. Host interface boards are available for ISA bus, PCI bus and NUBUS. Moving the ITC-18 from one platform to another is a simple matter of replacing the host interface board.

This configuration is unique to data acquisition units. Most data acquisition devices are printed circuit-boards installed directly in the computer itself. The interior of a computer is an electrically noisy environment. At the very high speeds of modern computers, even a short length of a conductive trace on a PC board acts as an antenna. Certain kinds of data acquisition devices are not affected by such noise (e.g. slow-speed integrating A/D converters), but high speed high-resolution A/D and D/A converters like the ones used in the ITC-18 are affected by such noise. Mounting the electronics in an external box is the most effective way of reducing this noise.

Optical Isolation:

The analog electronics of the ITC-18 are optically isolated from the digital electronics and the computer. This provides complete electrical isolation between the computer and the measurement.

The optical isolation is provided to eliminate computer electrical noise from the analog measurements. Computers contain digital electronics that switch at high speed, producing large electrical transients. The computer ground functions as the return path for these transients, resulting in substantial high-frequency ground noise. The ITC-18 has a completely separate analog ground that is isolated from the computer ground. Computer ground noise is not coupled into the measurement.

Optical isolation is almost essential if low-noise analog outputs are provided. If the analog outputs are not electrically isolated from the computer ground, the analog output ground will contain computer-generated noise. This is one of the major ways by which computer-generated noise is introduced into a measurement system.

The optical isolation of the ITC-18 brings with it another benefit that simplifies complex measurement systems. Since the analog inputs and outputs of the ITC-18 float with respect to ground, the ITC-18 and computer are not a source of ground loop problems.

Analog Circuitry:

The ITC-18 provides eight 18 bit A/D converters that feature individually programmable input range of ± 1 , ± 2 , ± 5 , or ± 10 volts. Using separate A/D converters for each analog input channel eliminates crosstalk between channels and improves the frequency response of the analog inputs.

Typical data acquisition devices use a single A/D converter with a multiplexer to select between input channels. The multiplexer, usually an integrated circuit, is a single point where all analog input signals connect. Crosstalk, both from the multiplexer itself and from closely-spaced printed-circuit board traces, causes signals appearing at one analog input to appear at other inputs as well. The amount of crosstalk is usually frequency-dependent. High-frequency signals can be affected significantly.

The ITC-18 design is particularly important when making measurements using multiple high-frequency signal sources and analyzing the signals for correlation. An added benefit to the ITC-18 design is that all analog inputs can be sampled simultaneously. This simplifies analysis of high-frequency correlation between signals, since there is no time offset between sample points on the input channels.

The ITC-18 provides four 18 bit D/A converters that feature high accuracy with less than 1 bit (~300 microvolts) of noise.

The ITC-18 provides sixteen digital input channels that feature level sensitive (normal or inverted polarity) or latched modes for maximum versatility. Thirty-two digital output channels, fourteen capable of current sink, for controlling perfusion valves and other devices. Six programmable sequencer outputs for precise triggering from any entry in the sequence RAM. All analog and digital input and output channels are sampled simultaneously for maximum precision.

The ITC-18 can access the A/D, D/A and digital I/O channels in any sequence. This provides the ability of different sampling rates for each channel.

FIFO Memory:

The ITC-18 is supplied with a large 1024 kilosample dynamically allocatable FIFO memory for input and output data. The ITC-18 allows data acquisition to be performed independent of the activity of the host computer. A large FIFO memory allows for increased acquisition speed while minimizing the use of computer resources.

The ITC-18 costs more than low-cost data acquisition devices, which are built as printed circuit boards mounted in a computer, without electrical isolation and multiplexing a single A/D converter. For this extra cost, it provides a major improvement in the quality of acquired data, making measurements possible that would not otherwise be feasible.

1.7 Explanation of symbols





Symbol	Description
	Alternating current Curreant alternatif Wechselstrom Corriente alterna Corrente variabile
	On (Supply) Allumé (alimentation) An (Netz) Encendido (suministro) Sotto tensione
	Off (Supply) Éteint (alimentation) Aus (Netz) Apagado (suministro) Fuori tensione
	Caution Attention Vorsicht Cuidado Cautela
	Protective conductor terminal Borne du conducteur de protection Schutzleiterpol Terminal de conductor protector Morsetto di filo di protezione

Figure 1. Explanation of symbols

2 Controls and Functions

2.1 Front Panel Controls

Circled numbers reference to the diagram of the front panel.

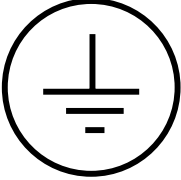
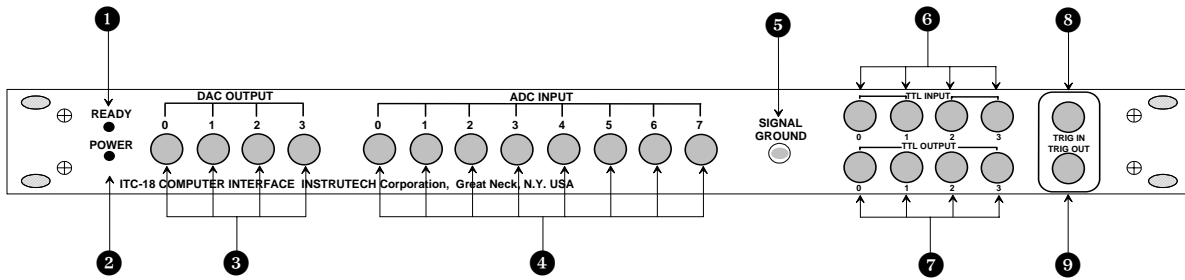

Figure 2: ITC-18 Front Panel Controls

1 READY indicator:

The ready indicator will be illuminated when the *ITC-18* has been properly initialized by the host computer and the acquisition software. If this indicator is not illuminated then the *ITC-18* cannot function properly.

2 POWER indicator:

The power indicator will be illuminated when the *ITC-18* has been powered on. The *ITC-18* uses circuitry that will automatically switch the internal power supply when the computer is started or shutdown.

3 DAC outputs:

Four BNC connectors provide access to the four individual deglitched 16 bit digital to analog converter outputs. All DAC outputs are thermally stabilized to reduce drift. The digital to analog converter output voltages and timings are controlled by the acquisition software. The DAC channels have an output range of -10.24 to +10.23 volts. These channels are optically isolated from the computer.

- 4 ADC inputs:**
Eight BNC connectors provide access to the eight individual 16 bit analog to digital converter input channels. Each A/D channel uses a high speed programmable gain instrumentation amplifier to provide individually selectable gain. Analog to digital converter channel selection and sampling interval timing is controlled by the acquisition software. The ADC channels have an input range of -10.24 to +10.23 volts. These channels are optically isolated from the computer. These channels are differential inputs. If the BNC connector shield is left unconnected unexpected results can occur. Use only high quality 75 ohm BNC cables for optimal results. The absolute maximum input range for these inputs is ± 40 volts. Do not exceed this level or damage can result to the input circuitry.
- 5 SIGNAL GROUND connector:**
A 3 mm banana receptacle provides connection to the internal analog ground. This low noise ground is provided for connecting to the recording amplifier. This ground connection is not connected to the *ITC-18* case or to the computer power supply ground. . If desired, the user should provide an external connection between the case and the instrument rack. The mating plug for this connector is a Keystone Electronics Corporation part number 6077.
- 6 TTL digital inputs:**
Four BNC connectors provide access to four out of the sixteen digital input channels. The digital input channels are controlled by the acquisition software. These digital input channels accept standard TTL levels (5 volts and 0 volts). These channels are optically isolated from the computer. The absolute maximum voltage range for these inputs is -0.5 volts to +5.5 volts. *Do not exceed this range or damage can result to the input circuitry.*
- 7 TTL digital outputs:**
Four BNC connectors provide access to four out of the sixteen digital output channels. The status of the digital output channels are controlled by the acquisition software. These digital channels output standard TTL levels (5 volts and 0 volts). These channels are optically isolated from the computer. These channels are optically isolated from the computer. These channels are optimized to drive 75 ohm BNC cables into an AC, HC, ACT, HCT or 8-TTL load.

8 TRIG IN:

A BNC connector provides access to the external trigger input. A TTL trigger pulse can be given to start data acquisition. The *ITC-18* will be triggered with a positive logic pulse with a minimum duration of 150ns. This input is not isolated. The absolute maximum voltage range for this input is -0.5 volts to +5.5 volts. *Do not exceed this range or damage can result to the input circuitry.*

9 TRIG OUT:

A BNC connector provides access to the sequencer out data bit 0. This sequence bit will switch with each timer period and does not use a time slot. Can be used as a gate output signal for triggering a scope or other instrument when data acquisition has started. The true functionality of this output is software dependent. This output is not isolated.

2.2 Rear Panel Controls

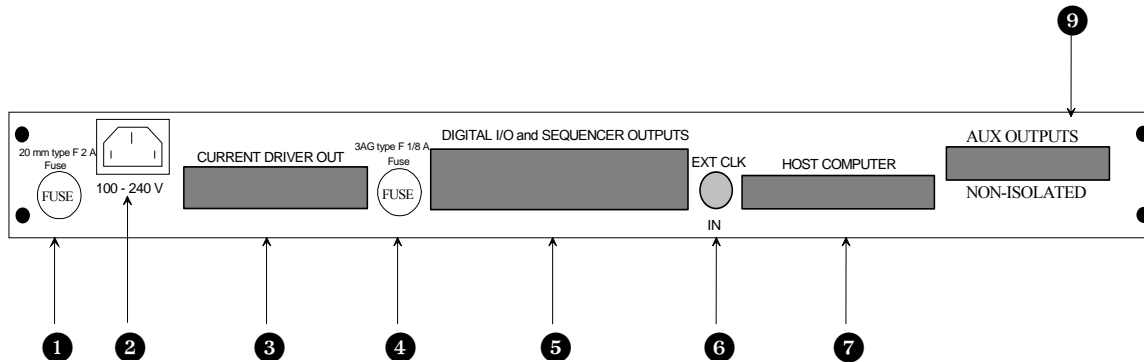

Figure 3: ITC-18 Rear Panel Controls

1 FUSE:

Replace fuse with a standard 20 mm type F 2A fuse only. Littelfuse #217002



2 POWER CONNECTOR:

Accepts standard three wire IEC female type power cords. The appropriate power cord will be provided with the *ITC-18*. The *ITC-18* will function with a line voltage of 100 volts AC to 120 volts AC or 200 volts AC to 240 volts AC. Acceptable line frequencies are from 47 hertz to 440 hertz. The maximum power used by the *ITC-18* is fifteen watts. **WARNING: To avoid a shock hazard, the *ITC-18* must be plugged into a properly grounded receptacle.**

3 CURRENT DRIVER OUT:

DB-25 female connector. The *ITC-18* provides 14 digital output channels that can be used either as standard TTL levels or as current sink. To use as current sink channels the connections to the external device is as follow:

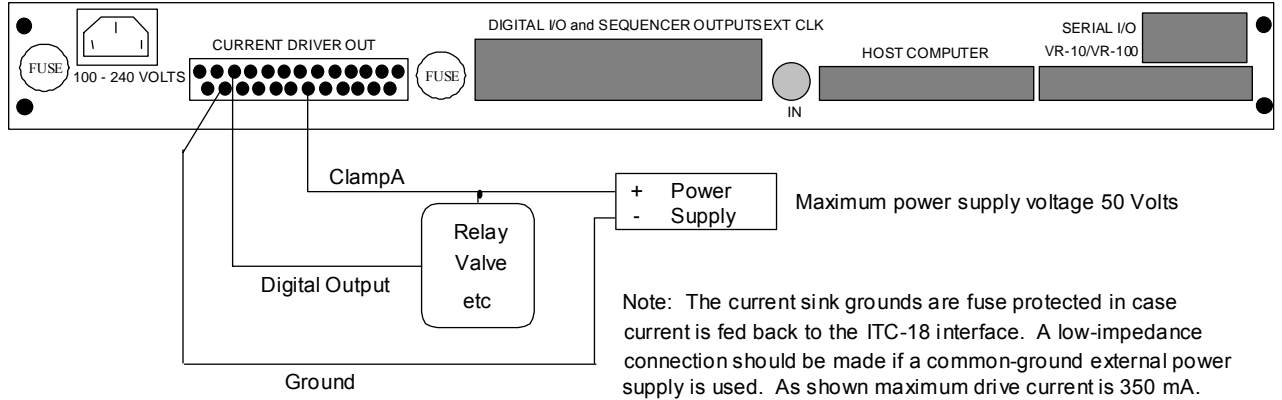

Figure 4: ITC-18 Current Driver Out external connections

4 FUSE:

Current driver out ground fuse. This fuse will open when current is fed back into the *ITC-18*. Replace fuse with a standard 1.5 inch type F 1/8A fuse only.

5 DIGITAL I/O & SEQUENCE OUTPUTS:

Dual 50 pin IDC connector. 16 Digital input lines with individual grounds, 16 Digital output lines with individual grounds (Channel 1) and 7 sequencer outputs with individual grounds.

6 EXT CLK: (optional)

BNC connector. The external clock option allows multiple *ITC-18* interfaces to be synchronized by an external master clock. Please contact Instrutech or your dealer for availability and specifications. If this option is installed, the absolute maximum voltage range for this input is ± 4 volts peak. *Do not exceed this range or damage can result to the input circuitry.*

7 HOST COMPUTER:

80 pin high density connector. Connection to host interface board. For Macintosh use either a MAC-18 (NUBUS bus host) or PCI-18 (PCI bus host) interface. For Intel based computers use either a AT-16 (ISA bus host) or PCI-18 (PCI bus host) interface. Note: the inter connecting cable is supplied with the host interface card.

9 AUX. OUTPUTS:

34 pin IDC connector. 16 auxiliary output lines with individual grounds.
These signals are not isolated and must use the non-isolated ground provided on this connector for proper operation.

3 Installation

3.1 Hardware installation

1. Turn the computer OFF.
2. Disconnect the power cord to the computer.
3. Remove the cover from the computer to access the computer's PCI expansion slots. Please follow the instructions outlined in your computer user's manual for removing the cover of the computer. Locate an empty PCI bus slot and remove the cover over the case access opening. Use caution here to guard against static, as outlined in chapter one. Remove the *PCI-18* card from the static shielding packaging. Line up the card-edge connector on the *PCI-18* board with the female connector on the CPU board. Gently press the two together until fully seated. If any resistance is felt please check for any proper alignment of the connectors. Do not force the two boards together. It should take minimal pressure to mate the two connectors. If excessive force is used here, damage could result to the *PCI-18* card and the computer main board. If your model computer uses a screw to secure the expansion cards in place, install the screw and make sure that it is fastened securely.

Note: On some model computers the rear bracket may not line up correctly against the inside of the computer case. For these computers, loosen the two screws on the PCI-18 card that hold the rear bracket in place. Adjust the bracket for a better fit and re-tighten the screws.

4. Re-install the cover of the computer.
5. Install the *ITC-18* interface into the operating position. Make sure that the interface can reach the computer with the supplied cable. Do not extend this cable. Unreliable operation can result if this cable is extended.
6. Install the cable between the *ITC-18* interface and the *PCI-18* computer board. The connectors on either end of the cable are keyed and will only mate when properly inserted. Fix the connectors in place with the screws attached to the connector. This is important to ensure a good electrical contact.
7. Connect the power cord to the *ITC-18*. The internal power supply used in the *ITC-18* is an auto switching multi-voltage supply that will operate from 100 volts to 260 volts. *Make sure that the ITC-18 power cord is plugged into a properly grounded AC receptacle. Improper grounding of the ITC-18 could result in an electrical shock hazard.* It is advisable to plug all equipment into a common outlet strip, this will minimize power line induced noise in the system. Equipment plugged into different outlets can cause excessive sixty hertz noise to be induced into the acquired data.



8. Before powering up please recheck all connections. If all connections are proper then the power led will illuminate once the computer is started.
9. You are now ready to power up the system and install the software. Follow the installation instructions provided with the acquisition software that will be used with this *ITC-18/PCI* interface.

4 Important considerations

4.1 Warm up

The ITC-18 digital to analog converter circuitry uses a sophisticated thermal stabilization technique to provide complete stability of the DAC outputs over time. For optimal stability of the DAC outputs the ITC-18 requires 20 to 30 minutes of warm up time. During this initial 20 minutes after the ITC-18 is turned on, DAC drift will occur. This drift can be as large as 6 mV during the initial warm up period. After this warm-up period the DAC outputs will be extremely stable.

4.2 Differential analog to digital inputs

The ITC-18 analog to digital converter inputs are true differential inputs. For proper operation of the A/D converter the cable connecting the A/D input to the signal source must have a complete shield. High quality 75 ohm BNC to BNC cables are recommended for optimum performance.

A connection should be made between the **SIGNAL GROUND** connector on the ITC-18 front panel to the signal ground connector on the signal source. Most patch clamp amplifiers provide a suitable connection point for the signal ground.

5 Troubleshooting

Most problems arise from incorrect installation of the hardware, and/or incorrect use of the software. The first thing to check is for proper installation of the hardware interface card.

Instrutech Corporation has utilities available for testing the *PCI-18* card under MacOS and DOS. This utility is available from Instrutech by Internet WWW or FTP. For access to our WWW site our URL is <http://www.instrutech.com/>. For access by anonymous FTP use the URL: <ftp://ftp.instrutech.com/>. If you do not have access to the Internet, call Instrutech and request the PCI utility disk.

Check the cable connecting the *PCI-18* card to the *ITC-18* interface. Make sure both ends are plugged in securely and that the cable is not damaged.

Check to see that the AC line cord is plugged in correctly.

Check the fuses on the *ITC-18* interface rear panel.

If all of the above steps fail to resolve the problem then contact your dealer for assistance.

6 Additional Software

6.1 Available Driver Software

Instrutech Corporation has available driver software for researchers and developers who wish to write custom applications using the *ITC-18* Interface. These drivers and appropriate manuals are available in both MacOS and Windows formats. They are available from Instrutech Corporation by request. They are also available from Instrutech Corporation by Internet WWW, FTP or email. For access to our WWW site our URL is <http://www.instrutech.com/>. For access by anonymous FTP use the URL: <ftp://ftp.instrutech.com/>. By email send an empty message to info@instrutech.com for a document that will describe how to access Instrutech files by email. If you do not have access to the Internet, call Instrutech and request the *ITC-18* driver disk of your choice.

6.2 Igor XOP's

Instrutech Corporation has available an XOP for Wavemetrics Igor that will allow researchers and developers to write custom applications using the *ITC-18* Interface and Wavemetrics Igor software. This XOP and the appropriate manual is available from Instrutech Corporation by request. It is also available from Instrutech Corporation by Internet WWW, FTP or email. For access to our WWW site our URL is <http://www.instrutech.com/>. For access by anonymous FTP use the URL: <ftp://ftp.instrutech.com/>. By email send an empty message to info@instrutech.com for a document that will describe how to access Instrutech files by email. If you do not have access to the Internet, call Instrutech and request the *ITC-18* XOP diskette.

7 Product Upgrades

7.1 PCI-18 adaptability

The *PCI-18* card is designed to be firmware upgradable by users, should this ever become necessary to keep up with new developments in the specification for the PCI bus. Do not attempt to do such an upgrade without the approval of Instrutech Corporation or one of its authorized agents. **If this upgrade is performed improperly, the *PCI-18* card will malfunction and become unusable.**

First you must acquire the proper upgrade software from Instrutech Corporation or one of its representatives. These upgrades will be announced on the Instrutech mailing list (See previous section of this manual) and on our Web site. The cover of the computer must be removed to access the *PCI-18* card in order to install a jumper. A programming jumper needs to be installed across the pins labeled "WE". Install this shunt with the computer powered off. After this shunt is installed power on the computer and run the software for your system. Update software will be made available in MacOS and DOS formats. The DOS program will run under Windows 3.1 and Windows 95. Windows NT users will need to boot their computer in DOS mode to perform this upgrade. After the software is run it should give you a successful completion message. The computer should then be powered down and the jumper removed from the "WE" pins. Close the computer and turn the power back on. The update has now been completed.

If there is any difficulty in this process, please contact your dealer.

8 Product Registration

8.1 Why Register your purchase?

Instrutech Corporation periodically offers enhancements and updates to our products. Without product registration, users of our products may miss out on announcements of important enhancements to the products that they are using.

Instrutech Corporation does not make our customer list available to anyone else. Any information that you provide to us is strictly confidential.

8.2 How to Register your purchase

Product registration can be accomplished in two ways. You may fill out and mail in the product registration/warranty card supplied with each Instrutech Corporation product. You may also register on-line at our World Wide Web site at <http://www.instrutech.com/>.

8.3 Product announcement mailing list

Instrutech Corporation has an Internet emailing list which we use as our primary outlet for announcements of new products, product enhancements and product updates. We strongly recommend that all users of our products sign up for this emailing list. Email is kept to a minimum and list membership is kept in the strictest confidence. Only Instrutech Corporation can send mail to members of our emailing list.

You may join this mailing list through our World Wide Web site at <http://www.instrutech.com/>. To do this select Instrutech email lists from the main menu. You may also sign up for this list by sending email to listserv@instrutech.com. In the body of this message place the line: **JOIN instrutech-list *your_email_address* *your_name***. If this subscribe message is sent from the account where you wish to receive your email, the *your_email_address* and *your_name* parameters are optional. This information will be extracted directly from the message.

9 Rear Panel Connector PIN Assignments

9.1 VR-10/100 Digital Data Recorder Connector

Below is a listing of the pin assignments of the optional VR-10/VR-100 port on the rear panel of the *ITC-18* interface. This port is optional and is not provided on standard configuration *ITC-18* units.

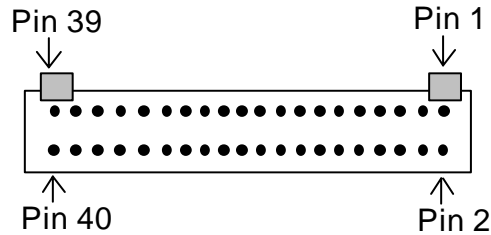

Figure 5: ITC-18 VR-10/VR-100 connector pins

Pin	Assignment	Pin	Assignment
1	PPMCM0 (channel mode)	2	PPMCM1 (channel mode)
3	PPMCM2 (channel mode)	4	PPMARS (analog reset)
5	* no connection	6	PPMCUE (CUE out)
7	* no connection	8	PPMCMP (FRAME out)
9	* no connection	10	Ground
11	* no connection	12	RSPCI (RS-232 Tx/D)
13	RSPC0 (RS-232 Rx/D)	14	Ground
15	Ground	16	Ground
17	PPMPLY(Play/Rec. mode)	18	Ground
19	no connection	20	Ground
21	Ground	22	PPMD0 (data bit 0)
23	PPMD1 (data bit 1)	24	PPMD2 (data bit 2)
25	PPMD3 (data bit 3)	26	PPMD4 (data bit 4)
27	PPMD5 (data bit 5)	28	PPMD6 (data bit 6)
29	PPMD7 (data bit 7)	30	PPMD8 (data bit 8)
31	PPMD9 (data bit 9)	32	PPMD10 (data bit 10)
33	PPMD11 (data bit 11)	34	PPMD12 (data bit 12)
35	PPMD13 (data bit 13)	36	PPMERR (ERROR bit)
37	PPMSTR (valid data flag)	38	PPMTRG (TRIGGER bit)
39	Ground	40	Ground

* Do not ground these connections they are used by the VR-10/100.

9.2 Serial I/O Connector

Below is a listing of the pin assignments of the male serial port connector on the rear panel of the *ITC-18* interface.



Figure 6: ITC-18 Serial Port connector pins

Pin	Assignment
1	RLSD: received line signal detect
2	RxD: receive data
3	TxD: transmit data
4	DTR: data terminal ready
5	Ground
6	DSR: data set ready
7	RTS: request to send
8	CTS: clear to send
9	RI: ring indicator

9.3 Current Driver Out Connector

Below is a listing of the pin assignments of the Current Driver Out connector on the rear panel of the *ITC-18* interface.

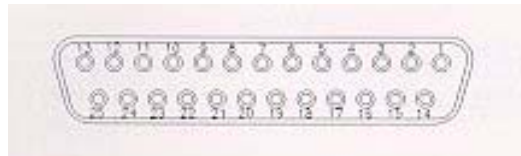

Figure 7: ITC-18 Current Driver Out connector pins

Pin	Assignment	Pin	Assignment
1	Clamp B (bank 2)	14	out channel 13 (bank 2)
2	out channel 12 (bank 2)	15	out channel 11 (bank 2)
3	Ground	16	out channel 10 (bank 2)
4	Ground	17	out channel 9 (bank 2)
5	Ground	18	out channel 8 (bank 2)
6	Ground	19	out channel 7 (bank 2)
7	Ground	20	clamp A (bank 1)
8	Ground	21	out channel 6 (bank 1)
9	Ground	22	out channel 5 (bank 1)
10	Ground	23	out channel 4 (bank 1)
11	Ground	24	out channel 3 (bank 1)
12	out channel 2 (bank 1)	25	out channel 1 (bank 1)
13	out channel 0 (bank 1)		

9.4 Digital I/O and Sequence Out Connector

Below is a listing of the pin assignments of the Digital I/O and Sequence Out port on the rear panel of the ITC-18 interface.

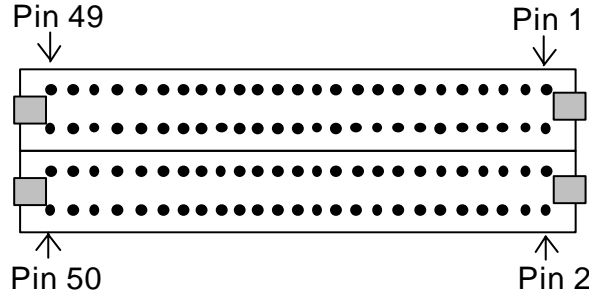

Figure 8: ITC-18 Digital I/O and Sequencer Out connector pins

Pin	Top Connector	Bottom Connector	Pin	Top & Bottom Connector
1	Ground	no connection	2	Ground
3	TTL input bit 8	TTL input bit 0	4	Ground
5	TTL input bit 9	TTL input bit 1	6	Ground
7	TTL input bit 10	TTL input bit 2	8	Ground
9	TTL input bit 11	TTL input bit 3	10	Ground
11	TTL input bit 12	TTL input bit 4	12	Ground
13	TTL input bit 13	TTL input bit 5	14	Ground
15	TTL input bit 14	TTL input bit 6	16	Ground
17	TTL input bit 15	TTL input bit 7	18	Ground
19	TTL channel 0 bit 12	TTL channel 0 bit 8	20	Ground
21	TTL channel 0 bit 13	TTL channel 0 bit 9	22	Ground
23	TTL channel 0 bit 14	TTL channel 0 bit 10	24	Ground
25	TTL channel 0 bit 15	TTL channel 0 bit 11	26	Ground
27	TTL channel 1 bit 8	TTL channel 1 bit 0	28	Ground
29	TTL channel 1 bit 9	TTL channel 1 bit 1	30	Ground
31	TTL channel 1 bit 10	TTL channel 1 bit 2	32	Ground
33	TTL channel 1 bit 11	TTL channel 1 bit 3	34	Ground
35	TTL channel 1 bit 12	TTL channel 1 bit 4	36	Ground
37	TTL channel 1 bit 13	TTL channel 1 bit 5	38	Ground
39	TTL channel 1 bit 14	TTL channel 1 bit 6	40	Ground
41	TTL channel 1 bit 15	TTL channel 1 bit 7	42	Ground
43	sequence out 4	sequence out 0	44	Ground
45	sequence out 5	sequence out 1	46	Ground
47	sequence out 6	sequence out 2	48	Ground
49	no connection	sequence out 3	50	Ground

9.5 Auxiliary Output Connector

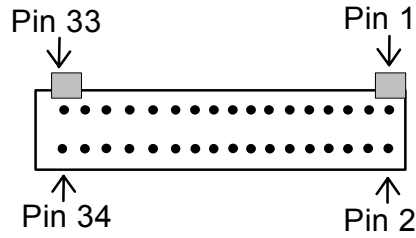

Figure 9: ITC-18 Auxiliary output connector pins

<u>Signal</u>	<u>Pin</u>	<u>Signal</u>	<u>Pin</u>
Ground	1	Ground	2
Out 0	3	Ground	4
Out 1	5	Ground	6
Out 2	7	Ground	8
Out 3	9	Ground	10
Out 4	11	Ground	12
Out 5	13	Ground	14
Out 6	15	Ground	16
Out 7	17	Ground	18
Out 8	19	Ground	20
Out 9	21	Ground	22
Out 10	23	Ground	24
Out 11	25	Ground	26
Out 12	27	Ground	28
Out 13	29	Ground	30
Out 14	31	Ground	32
Out 15	33	Ground	34

10 Warranty Information

10.1 Limited Warranty

Instrutech Corporation warrants to the first purchaser, for a period of two years from the date of purchase, that this Instrutech Instrument (hereafter referred to as the "Product") will be free from defective workmanship and materials, and agrees that it will, at its option, either repair the defect or replace the defective Product or part thereof at no charge to the purchaser for parts and labor. The Product must be returned to Instrutech Corporation, postpaid and insured. Instrutech Corporation will return the Product, postpaid and insured, in the most appropriate method as determined by Instrutech Corporation. If a faster shipping service is desired by the customer, any additional special delivery expenses must be paid by the customer.

This warranty does not apply to shipping damage. Instrutech Corporation fully insures all shipments. Any claims of damage upon receipt must be filed with the carrier and Instrutech Corporation immediately.

This warranty does not apply to any exterior appearance item of the Product which has been damaged or defaced, which has been subjected to misuse and abuse, abnormal service or handling, or which has been altered or modified in design or construction.

This warranty does not apply to any interconnection cables supplied with the Product.

This warranty does not apply if any unauthorized repairs, modifications or alterations have been made to the Product.

This warranty applies to software products only to the extent of maintenance release software to correct improper operation of the Product. Software updates to increase the capabilities of the present product are not to be provided under the terms of this warranty. Updates will be sent at no cost to the customer by normal common carrier routes. If faster delivery is desired, the customer must assume any additional expenses for special delivery service.

No sales organizations, other than Instrutech Corporation itself, are authorized to make any warranties other than those described above, or to extend the duration of any warranties beyond the time period described above on the behalf of Instrutech Corporation. If Instrutech Corporation agrees to such a modification of this warranty, Instrutech will furnish a modified copy of this agreement, which must be presented if a claim is being made under these modified terms.

10.2 Obtaining Warranty Service

Warranty service of this Product can be obtained by returning the Product, post paid and insured, to Instrutech Corporation, or one of its sales agents. Prior authorization before shipping the product is advised for the most expedient service.