

User manual for your

# BYO152.5SS

## 60 cm Fan oven

***NOTE:*** *This User Instruction Manual contains important information, including safety & installation points, which will enable you to get the most out of your appliance. Please keep it in a safe place so that it is easily available for future reference; for you or any person not familiar with the operation of the appliance.*

# Contents

<b>Environmental note</b>	3
<b>Important safety information</b>	4 - 6
<b>Specifications</b>	7 – 8
Product and aperture dimensions	7
Product specifications	7
Standard accessories	7
Optional extra	7
Electrical details	7
Cooling fan	8
Control panel	8 - 9
<b>Using your oven</b>	9 –16
Before first use	9
<b>Setting and using the oven programmer/timer</b>	10-13
Selecting manual operation mode	10
Setting the time of day	10
Using the minute minder	10
Setting the duration function	11
Setting the end cook function	12
Setting the start and end time function	13
Adjusting the audible signal	13
Selecting an oven function	14
Oven functions	14
Thermostat control knob	14
Oven operating light	15
Cooking guidelines	15
Warnings	16
Shelf positions	16
<b>Cleaning and maintenance</b>	17-19
Replacing the oven bulb	18
Removing the oven door for cleaning	18-19
<b>Installation</b>	19-22
Electrical connection	20
Installing the oven into the kitchen cabinet	21
Positioning the appliance	21
Ventilation requirements	22
<b>My appliance isn't working correctly</b>	23-24
<b>Contact details</b>	28

**This appliance is marked according to the European directive 2002/96/EC on Waste electrical and Electronic Equipment (WEEE). By ensuring this product is disposed of correctly, you will help prevent potential negative consequences for the environment and human health, which could otherwise be caused by inappropriate waste handling of this product.**

The symbol  on the product, or on the documents accompanying the product, indicates that this appliance may not be treated as household waste. Instead it shall be handed over to the applicable collection point for the recycling of electrical and electronic equipment.

**Disposal must be carried out in accordance with local environmental regulations for waste disposal.**

**For more detailed information about treatment, recovery and recycling of this product, please contact your local city office, your household waste disposal service or the shop where you purchased the product.**



- The packaging materials that we use are environmentally friendly and can be recycled.
- Please discard all packaging material with due regard for the environment.

## IMPORTANT SAFETY INFORMATION



Your safety is of the utmost importance to us. Please make sure that you read this instruction booklet **before** attempting to install or use the appliance. If you are unsure of any of the information contained in this booklet, please contact the Advice Line.

### General Information

- This appliance is designed for domestic household use and can be built into a standard kitchen cabinet or housing unit.
- **IMPORTANT:** *The adjacent furniture or housing and all materials used in the installation **must** be able to withstand a minimum temperature of 85°C above the ambient temperature of the room it is located in, whilst in use.*
- Certain types of vinyl or laminate kitchen furniture are particularly prone to heat damage or discolouration at temperatures below the guidelines given above.
- Any damage caused by the appliance being installed in contravention of this temperature limit, or by placing adjacent cabinet materials closer than 4mm to the appliance, **will be the liability of the owner.**
- The use of this appliance for any other purpose or in any other environment without the express agreement of the manufacturer will invalidate any warranty or liability claim.
- Your new appliance is guaranteed against electrical or mechanical defects, subject to certain exclusions that are noted in the Conditions Of Guarantee. The foregoing does not affect your statutory rights.
- **Repairs may only be carried out by registered service engineers or authorised service agents.**

### Warning and safety instructions

- This appliance complies with all current European safety legislation. We do wish to emphasise that this compliance does not remove the fact that the appliance surfaces **will become hot during use and retain heat after operation.**

## Child Safety

- We strongly recommend that babies and young children are prevented from being near to the appliance and not allowed to touch the appliance ***at any time.***
- If it is necessary for younger family members to be in the kitchen, please ensure that they are kept under close supervision at all times.

## General Safety

- ***Do not*** place heavy objects on the oven door or lean on the oven door when it is open, as this can cause damage to the oven door hinges.
- ***Do not*** leave heated oil or fat unattended, as this is a fire risk.
- ***Do not*** place pans or baking trays directly on the base of the oven cavity, or line it with aluminium foil.
- ***Do not*** allow electrical fittings or cables to come into contact with areas on the appliance that get hot.
- ***Do not*** use the appliance to heat the room it is located in or to dry clothing.
- ***Do not*** install the appliance next to curtains or soft furnishings.
- ***Do not*** attempt to lift or move cooking appliances by using the oven door or handle, as this may cause damage to the appliance or result in injury to the person lifting the appliance.

## Cleaning

- Cleaning of the oven should be carried out on a regular basis.
- Great care should be taken whilst using this appliance and when following the cleaning procedure.
- ***IMPORTANT:*** *The appliance must be disconnected from the mains before following the cleaning procedure.*

## Installation



*This appliance must be correctly installed by a suitably qualified person, strictly in accordance with the manufacturer's instructions.*

- *The manufacturer declines any responsibility for injury or damage, to person or property, as a result of improper use or installation of this appliance.*
- Heat, steam and moisture will be created during use of the appliance, take care to avoid injury and ensure that the room is adequately ventilated. If the appliance is going to be used for prolonged periods of time, then additional ventilation may be required.
- Please consult with your qualified installer if you are in any doubt about the amount of ventilation that you will require.

## Declaration of conformity

This appliance complies with the following European Directives:

- 2006/95/EC regarding "low voltage"
- 2004/108/EC regarding "electromagnetic disturbances"
- Regulation (EC) N° 1935/2004 regarding "materials in contact with food"
- The above directives comply with 93/68/EEC regarding CE marking.
- The manufacturer declares that the oven is built using certified materials and requires the appliance to be installed in accordance with the standards currently in force. This appliance must be used by a trained person for domestic purposes only.

## Specifications

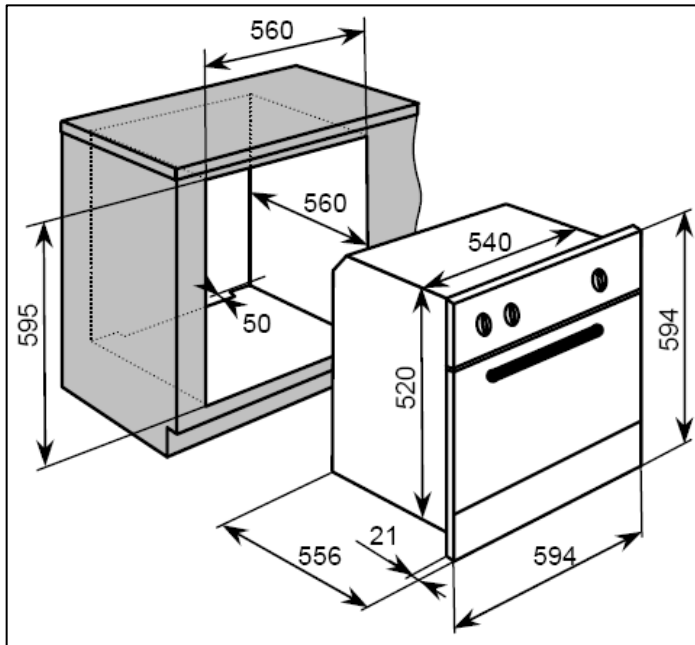

### Product Dimensions

Height: 594 mm  
Width: 594 mm  
Depth: 556 mm

### Aperture Dimensions

Height: 595 mm  
Width: 560 mm  
Depth: 560 mm

### Product specifications

- 4 oven functions
- Energy efficiency class: A
- Oven gross capacity: 67 litres
- Oven net capacity: 58 litres
- LED full programmer
- Cooling fan
- Double-glazed removable door
- Thermostatically controlled grill

### Standard accessories

- Safety shelf
- Enamelled baking tray with handle
- Trivet

### Optional extra

- BPS2 Pizza stone

### Electrical details

**Rated Voltage:**

220 - 240 Vac 50/60 Hz

**Supply Connection:**

13A (double pole switched fused outlet with 3mm contact gap)

**Max Rated Inputs:**

2.40 kW

**Mains Supply Lead:**

3 x 1.5mm<sup>2</sup>

**Oven Light Bulb:**

25 W/300°C screw type pygmy

## Cooling fan

- A tangential cooling fan is fitted inside of this appliance, to make the internal temperature of the oven stable and the external surface temperature lower.
- After you have finished cooking and switched off the oven, the cooling fan will continue to run for a period of time afterwards. The length of time will depend on how long the oven has been switched on for and at how high a temperature.

For future reference please record the following information which can be found on the rating plate and the date of purchase which can be found on your sales invoice. The rating plate for your oven can be located by opening the oven door and looking around the outer edge of the oven chassis.

**Model Number** .....

**Serial Number** .....

**Date of Purchase** .....

### Control Panel

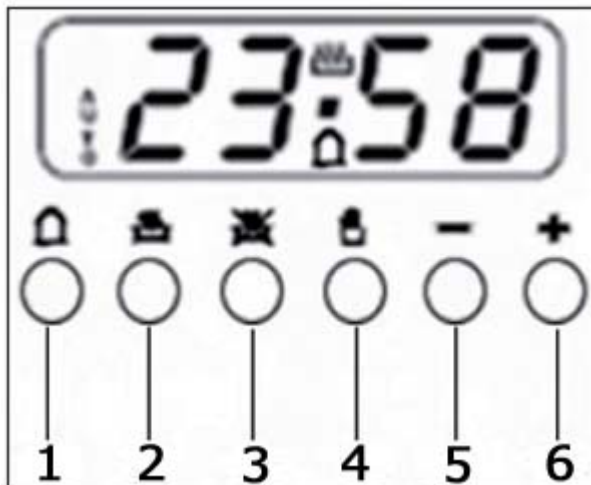
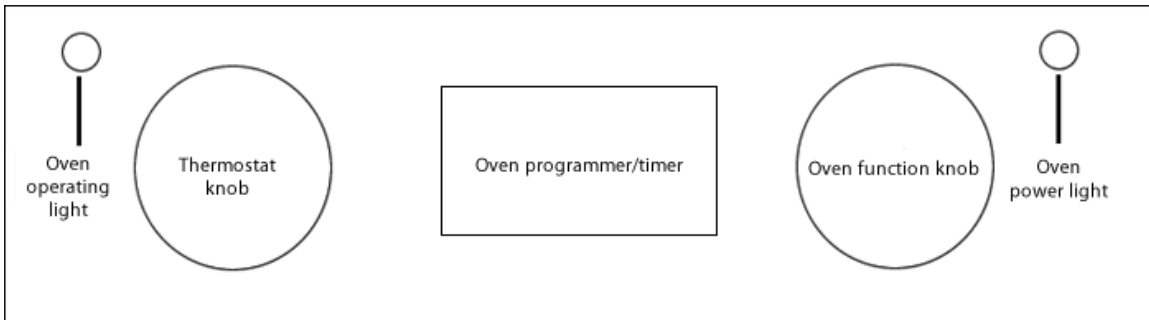

- 1) Minute minder button
- 2) Duration button
- 3) End cook button
- 4) Manual operation button
- 5) Minus button
- 6) Plus button



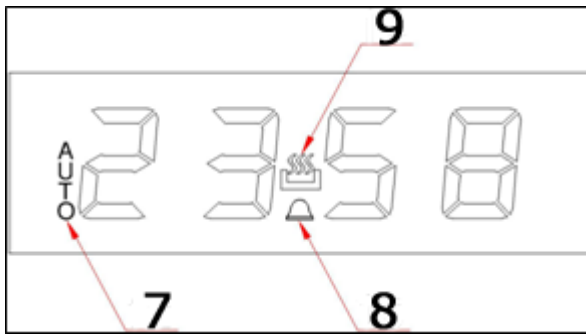

- 7) Auto function symbol
- 8) Minute minder symbol
- 9) Manual operation symbol

## Using your oven

### Before first use

- To remove any residue from the oven that may have been left from the manufacturing process, you should select the fan oven function and set the thermostat to its maximum temperature setting.
- It is perfectly normal for a smell to be produced during this process.
- You should make sure that any windows in the room are left open during this process.
- It is advisable for you not to remain in the room whilst the burning off process is taking place.
- You should leave the oven on maximum setting for 30 – 40 minutes.
- After the oven cavity has cooled, it should then be cleaned with warm soapy water, using either a sponge or soft cloth. No abrasive cleaners should be used.
- Outer parts of the oven should be cleaned with warm soapy water, using either a sponge or soft cloth. No abrasive cleaners should be used.
- We would recommend that an appropriate stainless steel cleaner and polish is regularly used on the stainless steel surfaces of this appliance.

## Initial set-up of your oven

### Selecting manual operation mode

*After your appliance is connected to the mains supply for the first time, the numbers on the timer display will flash. Before you can select a cooking function or set a temperature, you must set the appliance into manual operation mode.*

- To select manual operation mode, press the manual operation button **(4)** on the oven programmer / timer.

### Setting the time of day

*After setting your oven for manual operation, you should also set the time of day.*

- To enter the time setting mode press the duration **(2)** and end cook **(3)** buttons simultaneously.
- You can then use the minus button **(5)** and plus button **(6)** to adjust the time that appears in the display. After getting the display to the correct time, release the minus and plus buttons. After 5 seconds the time will set on the display and you will be able to use your oven.
- The manual operation symbol **(9)** will light on the oven programmer / timer display.

## Timer functions

### The minute minder function

*You are able to set the minute minder at any time, regardless of whether an oven function has been selected. You can set a countdown period using the minute minder function and an alarm will sound when this period of time has elapsed.*

- Press the minute minder button **(1)**, the display will show a value of 00:00. Set the period of time that you wish the minute minder to countdown for, by using the minus **(5)** and plus **(6)** buttons.
- Once the display has got to your desired countdown time, let go of the minus and plus buttons. The minute minder symbol **(8)** will appear on the timer display.
- Once a countdown time has been set, it is possible to shorten or lengthen the time by using the minus or plus buttons.

- An alarm will sound when the countdown time has elapsed. The alarm can be silenced by pressing the minute minder button **(1)** or manual operation button **(4)**.
- ***Important: The oven will continue to heat once the alarm has been silenced. If you have finished cooking, then you should turn the oven function selector and thermostat control knob to the off position ('0').***

## The duration function

*This function will allow you to set a countdown time similar to the minute minder function, however the oven will switch off at the end of the cooking time.*

- Use the oven function selection knob to select the mode of cooking that you require.
- Use the oven thermostat control knob to set the temperature that you require. The manual operation symbol **(9)** will appear on the display.
- It is then possible to set the duration of the cooking time that you require.
- Press the duration button **(2)** and the display will show a value of 00:00. Set the period of time that you wish the duration function to countdown for, by using the minus **(5)** and plus **(6)** buttons.
- Once the display has got to your desired countdown time, let go of the minus and plus buttons. The countdown will start immediately and the auto symbol **(7)** will appear on the timer display.
- Once the countdown time has been set, it is possible to shorten or lengthen the time by using the minus or plus buttons.
- An alarm will sound when the countdown time has elapsed and the oven will switch off. The auto symbol **(7)** will flash and the manual operation symbol **(9)** will disappear.
- To silence the audible signal and return the oven to manual operation mode, once the duration function has been used, you should press the manual operation button **(4)**. The auto symbol **(7)** will disappear from the display and the manual operation symbol **(9)** will appear instead.
- ***IMPORTANT: If you have not turned the main oven function selector knob and main oven thermostat control knob to their off positions ('0'), the appliance will continue to operate as soon as you press the manual operation button (4).***

## The end cook function

*This function is similar to the duration function, however instead of selecting a period of time that you wish the oven to switch off after, you select the time of day that you wish the oven to switch off at.*

- Use the oven function selection knob to select the mode of cooking that you require.
- Use the oven thermostat control knob to set the temperature that you require. The manual operation symbol **(9)** will appear on the display.
- Press the end cook button **(3)** and the display will show a value of 00:00. Set the time of day that you wish the oven to stop cooking at by using the minus **(5)** and plus **(6)** buttons. The timer will calculate how long the cooking time will be, based on the time of day that you have selected and show it on the display.
- Once the display has got to the time of day that you want the oven to stop cooking at, let go of the minus and plus buttons. The countdown will start immediately and the auto symbol **(7)** will appear on the timer display.
- When the time is set, it can be modified by pressing the minus and plus buttons.
- When the time of day reaches the end of the cooking time that you have set, the oven will switch off and an alarm will sound. The auto symbol **(7)** will flash and the manual operation symbol **(9)** will disappear.
- To silence the audible signal and return the oven to manual operation mode, once the end cook function has been used, you should press the manual operation button **(4)**. The auto symbol **(7)** will disappear from the display and the manual operation symbol **(9)** will appear instead.
- ***IMPORTANT: If you have not turned the main oven function selector knob and main oven thermostat control knob to their off positions ('0'), when you press the manual operation button (4) the oven will continue to operate.***

## The start and end time function

*This function will allow you to set a time in the future that the oven switches on at and a time that the oven will switch off at.*

- Use the oven function selection knob to select the mode of cooking that you require.
- Use the oven thermostat control knob to set the temperature that you require. The manual operation symbol **(9)** will appear on the display.
- Press the duration button **(2)** and the display will show a value of 00:00. Set the period of time that you wish to cook for, by using the minus **(5)** and plus **(6)** buttons. The auto symbol **(7)** will appear on the timer display.
- ***Immediately*** press the end cook button **(3)** and the timer display will show the value of 00:00. Set the time of day that you want the oven to switch off at, using the minus and plus buttons.
- The oven will calculate what time it needs to switch on at, so that your food will cook for the length of time that you selected. It will automatically switch itself on once it reaches the time of day that is has calculated.
- When the time of day reaches the end of cooking time that you set, the oven will switch off and an alarm will sound. The auto symbol **(7)** will flash and the manual operation symbol **(9)** will disappear.
- To silence the audible signal and return the oven to manual operation mode, once the start and end time function has been used, you should press the manual operation button **(4)**. The auto symbol will disappear from the display and the manual operation symbol will appear instead.
- ***Important: If you do not turn the thermostat control knob and oven function selection knob to the off position ('0'), the appliance will continue to operate as soon as you press the manual operation button (4).***

## Adjusting the volume of the audible signal

- To adjust the level of the audible signal, when it is sounding, press the minus button **(5)** and it will adjust through the 3 sound levels. Release the minus button and the sound level of the audible signal will be set.

## Selecting an oven function

The oven function selector knob should be used to select the particular mode of cooking that you require. The appliance will utilise different elements within the oven cavity, depending on the oven function that you select. When a function is selected, the power indicator light will come on and the oven light.

### Oven functions:



**OVEN LIGHT:** Separate light control which allows the light to be switched on, even when the oven is not in use.



**DEFROST MODE:** The fan runs without heat to reduce the defrosting time of frozen foods. The time required to defrost the food will depend on the room temperature, the quantity and type of food. Always check food packaging for the defrosting instructions.



**FAN OVEN:** This method of cooking uses the circular element while the heat is distributed by the fan. This results in a faster and more economical cooking process. The fan oven allows food to be cooked simultaneously on different shelves, preventing the transmission of smells and tastes from one dish onto another.



**FULL GRILL:** This method of cooking utilises the inner and outer parts of the top element, which directs heat downwards onto the food. This function is suitable for grilling medium or large portions of sausages, bacon, steaks, fish etc.

### Thermostat control knob

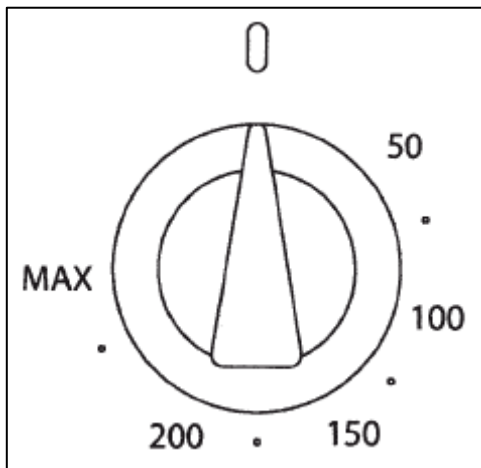

- The oven thermostat control knob sets the required temperature of the oven. It is possible to regulate the temperature within a range of 50 - 250°C.
- **Turn the control knob clockwise.**

## Oven operating light



- This light will come on to indicate that the oven's heating elements are in operation. The light will turn off when the temperature set on the thermostat control knob has been reached. It will cycle on and off throughout the cooking time.



***You should not place food inside the cavity, until the correct cooking temperature has been reached.***

## Cooking guidelines

- Please refer to the information given on food packaging for guidance on cooking temperatures and times. Once familiar with the performance of your appliance, temperatures and times can be varied to suit personal preference.
- You should pre-heat the oven and not place food inside of it until the oven operating light has gone off.
- ***IMPORTANT:*** *You should ALWAYS pre-heat the oven if you are baking.*
- Make sure that frozen foods are thoroughly thawed before cooking, unless the instructions on the food packaging advise that you can "cook from frozen".
- Before cooking, check that any accessories that are not required are removed from the oven.
- Place cooking trays in the centre of the oven and leave gaps between the trays to allow air to circulate.
- Try to open the door as little as possible to view the dishes.
- The oven light will remain on during cooking.

## Warnings

- Keep the oven door closed when using ALL oven functions, including the grill function.
- Do not use aluminium foil to cover the enamelled baking tray or heat items wrapped in aluminium foil under the grill. The high reflectivity of the foil could potentially damage the grill element.
- You should also never line the base of your oven with aluminium foil.
- During cooking, never place pans or cookware directly onto the bottom of your oven. They should always be placed on the shelf provided.
- The grill heating element becomes extremely hot during operation, avoid touching it inadvertently when handling the food which you are grilling.
- **Important:** Be careful when opening the door, to avoid contact with hot parts and steam.

## Shelf positions

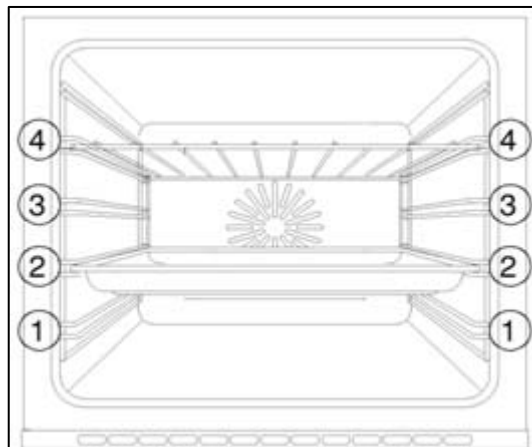

- The numbers 1 – 4, indicate the different shelf positions that you can utilise within the oven.
- You should use the shelf position(s) that you find are best suited to your personal cooking preferences.
- We recommend that food is placed on shelf level 3 when using the grill function. Shelf level 4 is too close to the grill element so there is a risk of burning the food.



## Cleaning and maintenance



*Cleaning operations must only be carried out when the oven is cool.*

*The appliance should be disconnected from your mains supply before commencing any cleaning process.*

- The oven should be thoroughly cleaned before it is operated for the first time and after each use. This will avoid residual food stuffs becoming baked on the oven cavity. After residues have been baked on several times, they are far more difficult to remove.
- **Never** clean the oven surfaces by steam cleaning.
- The oven cavity should only be cleaned with warm soapy water, using either a sponge or soft cloth. No abrasive cleaners should be used.
- Any stains that may appear on the bottom of the oven will have originated from food splashes or spilt food, these splashes occur during the cooking process. These could possibly be a result of the food being cooked at an excessively high temperature or being placed in cookware that is too small.
- You should make sure that the cooking temperature that is selected is appropriate for the food that you are cooking. You should also ensure that the food is placed in an adequately sized dish and use the enamelled baking tray where appropriate.
- Outer parts of the oven should only be cleaned with warm soapy water, using either a sponge or soft cloth. No abrasive cleaners should be used.
- We would recommend that an appropriate stainless steel cleaner and polish is regularly used on the stainless steel surfaces of this appliance.
- If you use any form of oven cleaner on your appliance, then you must check with the manufacturer of the cleaner that it is suitable for use on your appliance.
- ***Any damage that is caused to the appliance by a cleaning product will not be fixed by the manufacturer free of charge, even if the appliance is within the guarantee period.***

## Replacing the oven bulb



**IMPORTANT:** *The oven must be disconnected from your mains supply before you attempt to either remove or replace the oven bulb.*

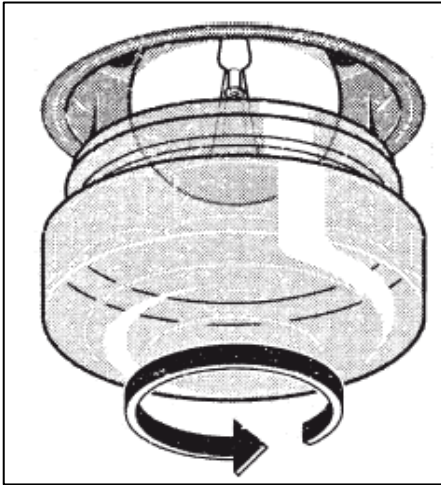

- Remove the oven shelf and the baking tray.
- It is recommended to line the base of the oven with a tea towel during this process to prevent damage if any parts are dropped.
- Unscrew the glass cover of the light.
- Unscrew the old bulb and remove it from its holder.
- Replace the bulb with a 25 W/300°C, screw type pygmy.
- **Do not** use any other type of bulb.
- Place the glass cover back into position.

## Removing the oven door for cleaning

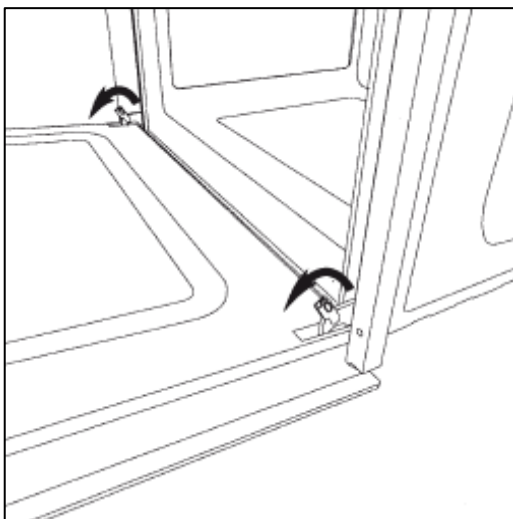

To facilitate the cleaning of the inside of the oven and the outer frame of the oven, the door can be removed as follows: -

- The hinges have two movable bolts on them.
- If you raise both of the movable bolts, then the hinges are released from the oven housing.

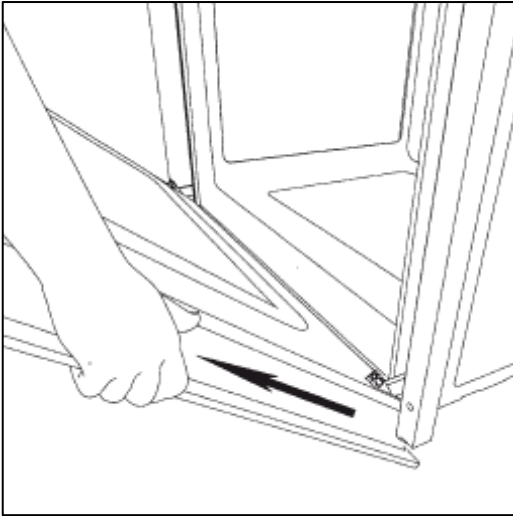

- You should grip the sides of the door at the centre and then incline it slightly towards the oven cavity and then pull the door gently away from the oven cavity.
- **IMPORTANT:** You should make sure that the door is supported at all times and that you place the door on some padded material whilst cleaning it.
- The oven door and door glass should only be cleaned using a damp cloth and a small amount of detergent. The cloth **MUST NOT** have come into contact with any form of cleaning product or chemical previously.
- To refit the door you should slide the hinges back into their slots and open the door fully.
- **IMPORTANT:** The movable bolts must be closed back into their original positions before closing the door.



- **Take care not to dislodge the hinge locking system when removing the door, as the hinge mechanism has a strong spring.**
- **Do not immerse the door in water at any time.**

## INSTALLATION



**The installation must be carried out by a suitably qualified person, in accordance with the current version of the following.**

- **UK Regulations and Safety Standards** or their European Norm Replacements.
- **Building Regulations** (issued by the Department of the Environment).
- **Building Standards** (issued by the Scottish Development Department).
- **IEE Wiring Regulations.**
- **Electricity At Work Regulations.**

## Electrical connection

Before connecting the appliance, make sure that the supply voltage marked on the rating plate corresponds with your mains supply voltage.

### **WARNING: THIS APPLIANCE MUST BE EARTHED.**

- This appliance should be wired into a 16 A double pole switched fused spur outlet, having 3 mm contact separation and placed in an easily accessible position adjacent to the appliance. The spur outlet must still be accessible even when your oven is located in its housing.

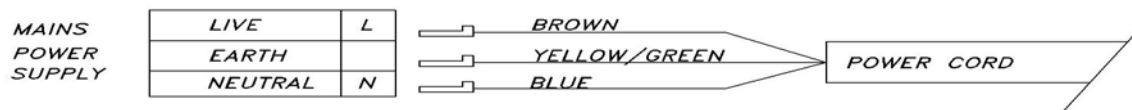

- To connect the oven power cord, loosen and remove the cover on the terminal block, in order to gain access to the contacts inside. Make the connection, securing the cord in place with the cable clamp provided and then immediately close the terminal block cover again.

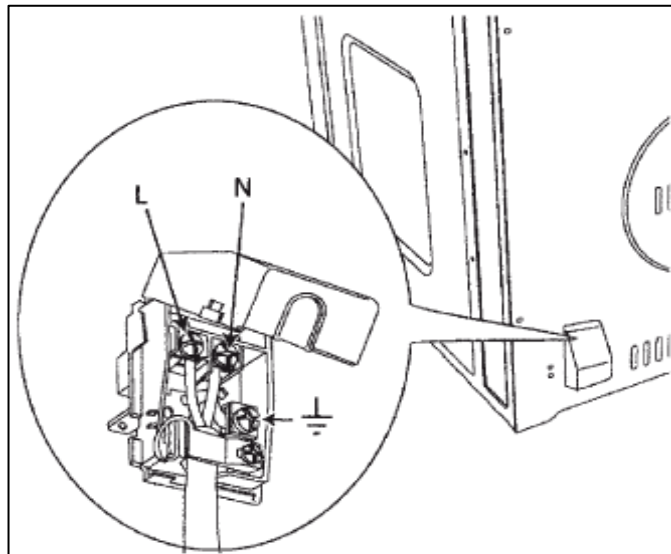

- If you have to change the oven power cord, the earthing (yellow/green) conductor must always be 10 mm longer than the line conductors.
- Care must be taken to ensure that the temperature of the mains supply cable does not exceed 50°C.
- If the mains supply cable is damaged, then it must be replaced by an appropriate replacement which can be obtained from the Spares Department.

## Installing the oven into the kitchen cabinet

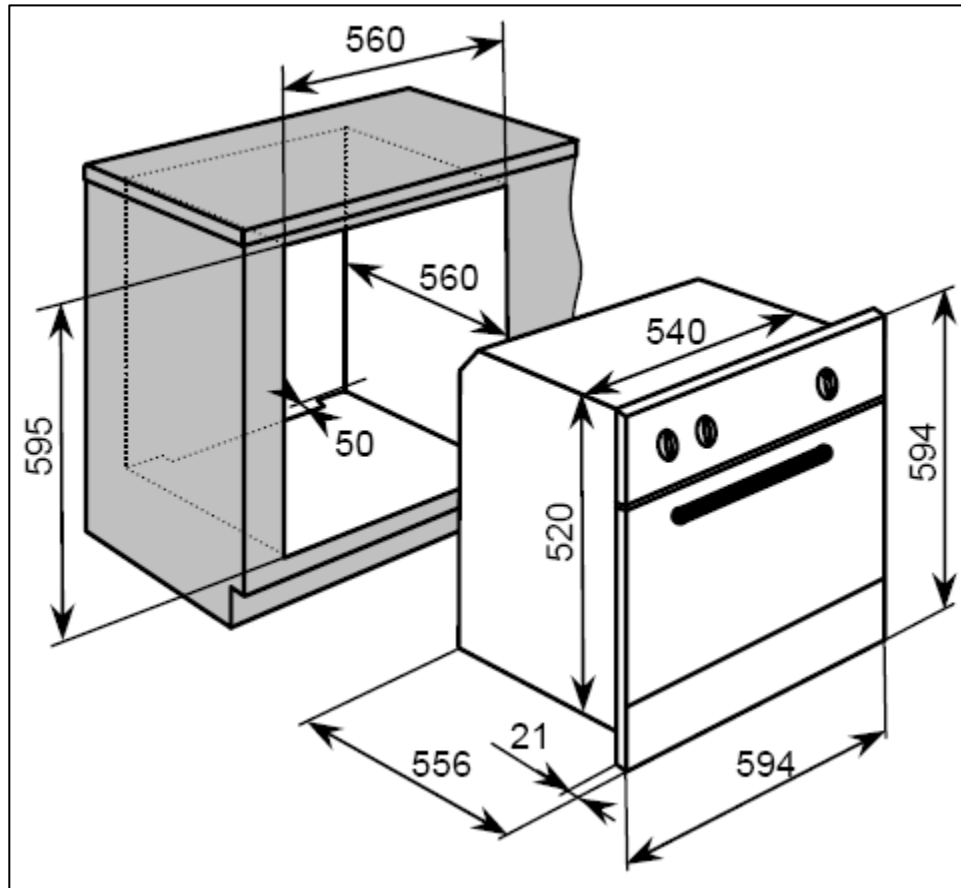

### Positioning the appliance

- Ensure that the aperture that you will be fitting the oven into is of the size given in the diagram above.
- The oven must be fitted into an oven housing with the ventilation cut-outs shown in the diagram above. Please also see "Ventilation requirements" on the following page.
- Ensure that the rear panel of the furniture housing unit has been removed.
- Align the oven centrally to the side walls of the surrounding units before you fix the appliance. The fixing of the oven into the housing is made using the screws and Allen screws provided. These should be screwed through the oven cabinet and into the housing unit.

## Ventilation requirements

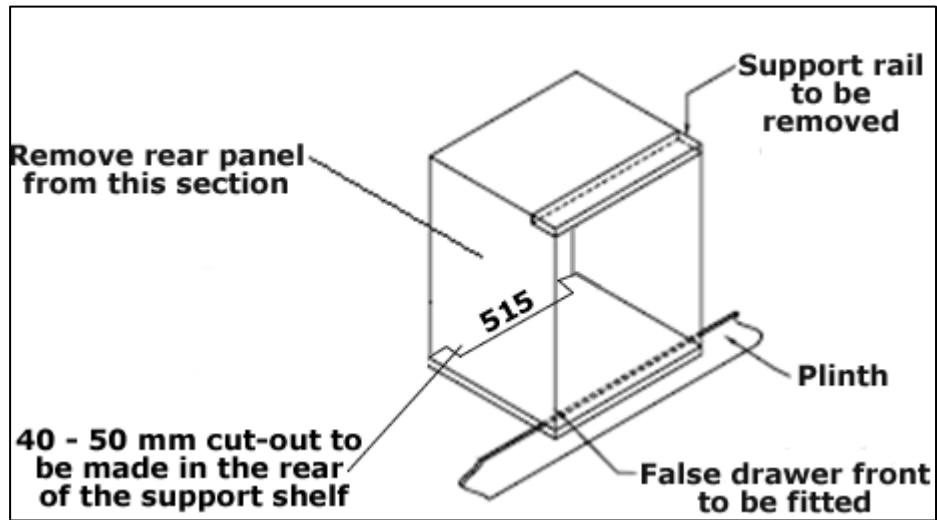

(Figure shows the ventilation and cut-out requirements for the installation of the appliance into a standard kitchen unit).

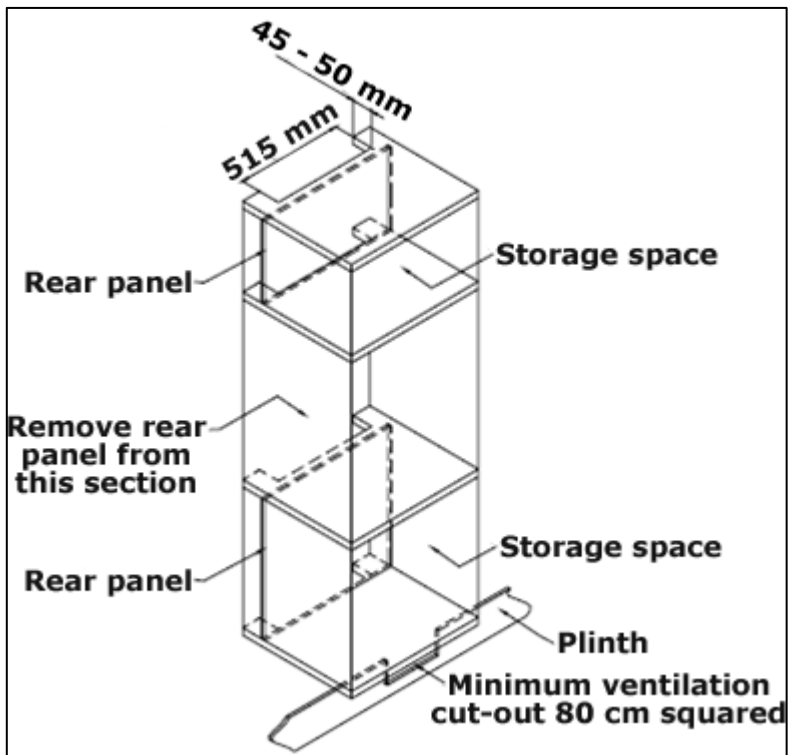

(Figure shows the ventilation and cut-out requirements for the installation of the appliance into a tall housing unit).

## My appliance isn't working correctly

- ***The oven isn't coming on.***
  - \* Check that you have selected a cooking function and a cooking temperature.
- ***There appears to be no power to the oven and grill.***
  - \* Check that the appliance has been connected to the electrical mains supply correctly.
  - \* Check that the mains fuses are in working order.
  - \* Check that the correct operating instructions for using the oven have been followed.
- ***The grill function works but the main oven does not.***
  - \* Check that you have selected the correct cooking function.
- ***The grill element is not working, or cuts out for long periods of time during use.***
  - \* Allow the oven to cool for approximately 2 hours. Once cool, check whether the appliance is again working properly.
- ***My food is not cooking properly.***
  - \* Ensure that you are selecting the correct temperature and the correct cooking function for the food that you are cooking. It may be appropriate to adjust your cooking temperature by plus or minus 10°C, to achieve the best cooking results.
- ***My food is not cooking evenly.***
  - \* Check that the oven has been installed correctly and is level.
  - \* Check that the correct temperatures and shelf positions are being used.
- ***The oven light is not working***
  - \* Refer to page 15 and follow the "Replacing the oven bulb" section.

- ***I am getting condensation in my oven***
- \* Steam and condensation is a natural by product of cooking any food with high water content, such as frozen food, chicken etc.
- \* You may get condensation in the oven cavity and forming between the oven door glasses. This is not necessarily a sign that the oven is not working correctly.
- \* Do not leave food in the oven to cool after it has been cooked and the oven has been switched off.
- \* Use a covered container, where practical, when cooking to reduce the amount of condensation that forms.



***IMPORTANT: If your appliance appears not to be operating correctly, then you should disconnect it from your mains supply and then contact the Advice Line on telephone number (0118) 933 6918.***

***DO NOT ATTEMPT TO REPAIR THE APPLIANCE YOURSELF.***

Please note that if an engineer is asked to attend whilst the product is under guarantee and finds that the problem is not the result of an appliance fault, then you may be liable for the cost of the call out charge.

***The appliance must be accessible for the engineer to perform any necessary repair. If your appliance is installed in such a way that an engineer is concerned that damage will be caused to the appliance or your kitchen, then he will not complete a repair.***

***This includes situations where appliances have been tiled in, sealed in with sealant, have wooden obstructions placed in front of the appliance, like plinths. Or any installation other than the one specified by the manufacturer has been completed.***

Please refer to the conditions of guarantee that appear on the warranty card that you receive with the appliance.

***IMPORTANT: The manufacturer operates a policy of continuous improvement and reserves the right to adjust and modify its products without prior notification.***









**United Kingdom**

6 Bennet Road,  
Reading, Berkshire  
RG2 0QX  
United Kingdom

**Customer Care**

(0118) 933 6918