



MODEL 4100 AC Rev D.
USER'S MANUAL

LAVERSAB INC.,

505 Gillingham Lane

Sugar Land TX, 77478

(281) 325-8300

FAX: (281) 325-8399

Email: oservice@laversab.com

Document Number : ____

Date: _____

WARRANTY

Laversab, Inc., warrants its products to conform to or exceed the specifications as set forth in its catalogs in use at the time of sale and reserves the right, at its own discretion, without notice and without making similar changes in articles previously manufactured, to make changes in materials, designs, finish, or specifications. Laversab Inc. warrants products of its own factory against defects of material or workmanship for a period of one year from date of sale.

Liability of Laversab, Inc. under this warranty shall be limited to replacing, free of charge (FOB Houston, Texas), any such parts proving defective within the period of this warranty, but Laversab, Inc. will not be responsible for transportation charges, consequential or incidental damages. No liability is assumed by Laversab for damages that are caused by misuse or abuse of the product.

The warranty of Laversab Inc. is not made for products manufactured by others which are illustrated and described in Laversab catalogs or incorporated in Laversab products in essentially the same form as supplied by the original manufacturer.

COPYRIGHT NOTICE

Copyright (c) 2003-2007 by Laversab Inc. All rights reserved. The content of this manual may not be reproduced in any form by any means, in part or in whole, without the prior written permission of Laversab Inc.

DISCLAIMER

No representations or warranties are made with respect to the contents of this user's manual. Further, Laversab Inc. reserves the right to revise this manual and to make changes from time to time in the content hereof without obligation to notify any person of such revision.

WARNING

THE 4100 USES LINE VOLTAGES FOR ITS OPERATION WHICH ARE POTENTIALLY DANGEROUS. IMPROPER OPERATION OF THIS EQUIPMENT MAY RESULT IN PERSONAL INJURY OR LOSS OF LIFE. HENCE THE EQUIPMENT DESCRIBED IN THIS MANUAL SHOULD BE OPERATED ONLY BY PERSONNEL TRAINED IN PROCEDURES THAT WILL ASSURE SAFETY TO THEMSELVES, TO OTHERS AND TO THE EQUIPMENT.

BEFORE PERFORMING ANY MAINTENANCE, TURN THE POWER OFF AND DISCONNECT THE POWER CORD FROM THE POWER SOURCE.

TABLE OF CONTENTS

Warranty	I
Copyright notice, disclaimer	ii
Revision History	iii
Warning	iv
Section 1: Introduction	1
Section 2: Safety	3
Section 3: Installation	5
3.1 Loading Software	5
3.2 Mounting the 4100	5
3.3 Connections to the 4100	7
3.3.1 Non-hazardous locations	7
3.3.2 Hazardous locations	8
Section 4: Typical Use	10
Section 5: Removal	12
Section 6: Maintenance & Servicing	13
Section 7: 4100 Wireless Radios	14
Appendix A: Ext. Connections in Hazardous / Non-Hazardous Locations	15
A.1 4100 (Standard model) and M2 model	15
A.1.1 Drawings: Back Connectors	18
A.1.2 Drawings: Cables for Non-Hazardous Locations	19
A.2 4100-M1 and M3 model	20
A.2.1 Drawings: Back Connectors	23
A.2.2 Drawings: Cables for Non-Hazardous Locations	24
Appendix B: Repair and Return Policies	25

SECTION 1

INTRODUCTION

The model 4100 Industrial computer is a PC-compatible computer that is specifically designed for use in hazardous locations that are classified as Class 1 Division 2. Typical applications include rig-floor monitoring and use in chemical plants. The rugged yet compact design of the 4100 makes it easy to install and remove off rig-floors and makes it suitable for use under all weather conditions. The 4100 is shown in Figure 1.1

The 4100 model is available in the following options:

4100 Rev C (Standard)

- a. 4100-M1 Rev C
- b. 4100-M2 Rev C
- c. 4100-M3 Rev C

Standard Features:

- Atom Single Core 1.6 GHz or Atom Dual Core 1.8 GHZ
- 15.0" TFT Color Ultra-Hibrite sunlight readable display with 1024 x 768 resolution
- Auto-dimming of display brightness based on ambient light
- High resolution, scratch resistant touch-screen
- Fully sealed redundant mouse
- Up to 2 GB System RAM
- 4 GB Internal Flash
- 2.5" form factor SSD 64 GB (optional)
- 110/220 VAC nominal operating voltage
- One USB ports, barrier protected
- One Ethernet port, barrier protected
- One external Keyboard port, barrier protected
- Two 900 MHZ Wireless Radio with antenna
- Internal heaters operating on 110/220 VAC allow operation between -40°C and +50°C
- Sealed enclosure allows operation outdoors
- Total weight of 25 lbs makes it easily portable
- Dimensions of 16.5" wide, 14.5" high and 4.5" deep provide a small form factor
- UL 1604 / CSA C22.2 No. 213 certified for use in Class 1 Division 2 locations Groups A, B, C and D; Temp code T6.

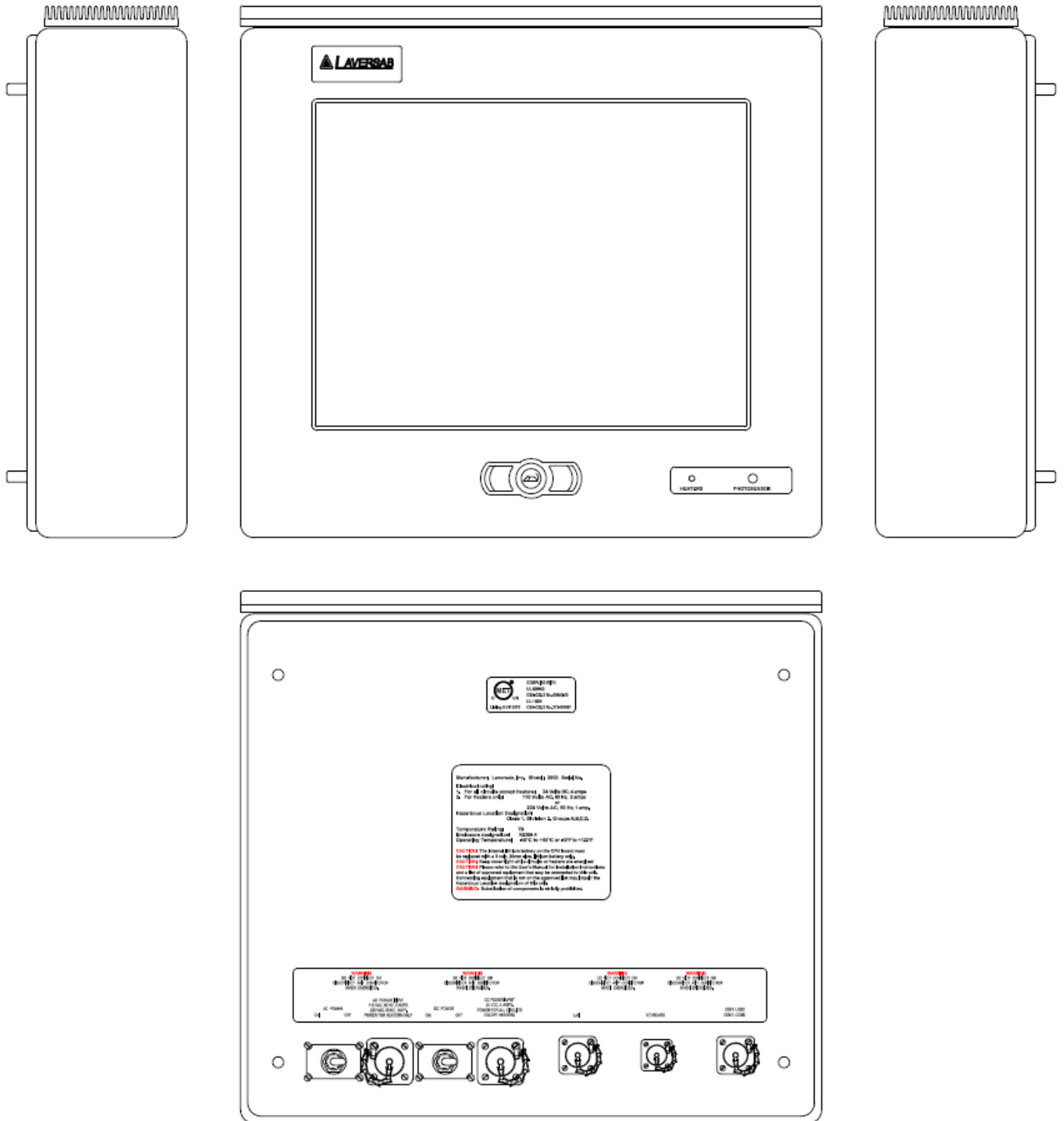

Figure 1.1

SECTION 2

SAFETY

The following safety instructions must be followed to prevent possible hazards of fire, electrical shock and bodily harm.

1. **WARNING :** The model 4100 must be connected to an appropriate power source as indicated on the information label on the rear panel of the unit.
2. **WARNING:** AC Units: The circuit breaker for the power connection on the rear panel of the unit must be in the OFF position such that the internal circuits are not energized, whenever the power source is either connected or disconnected from the unit.
3. **WARNING:** The unit must never be opened or left open in a hazardous location. The rear panel and the top heat sink must be securely fastened before the unit is introduced into a hazardous location.
4. **WARNING:** Do not install or operate this unit in an area where the temperature is outside the limits indicated on the information label on the rear panel of the unit.
5. **WARNING:** All connections made to the unit must strictly adhere to the rules set forth in Section 3.2 of this manual.
6. **WARNING:** There are no user-serviceable components inside this unit. The unit must not be opened to repair or replace any components. If components are repaired or replaced by the user, the unit may no longer be suitable for use in hazardous locations and may become an explosion hazard.
7. **WARNING:** The Model 4100 is suitable for use in Class I Division 2 (Groups A - D) hazardous locations and non-hazardous locations only.
8. **CAUTION:** Do not cover or obstruct the slots and fins on the top heat sink in a manner that would restrict air flow between the slots or across the fins.
9. **CAUTION:** Do not install the unit in an unstable manner that could cause it to tip over.
10. **CAUTION:** Follow all instructions and warnings marked on the unit and also those included in this manual.

Approvals:

The Model 4100 conforms to the following standards:

UL60950 / CSA 60950

CAN/CSA - C22.2 No. 60950.00

UL 1604

CAN / CSA - C22.2 No. 213-M1987

SECTION 3

INSTALLATION

The installation process consists of:

- a. Loading the application software onto the 4100
- b. Mounting the 4100 on-site using an appropriate mounting bracket.
- c. Making the connections to the 4100

3.1 Loading software

The 4100 is provided with a Windows operating system that is pre-installed with the network enabled. All software must be loaded through the USB ports (USB1.1 std.) . It is not necessary to open the unit to load the software.

If software modifications require that the unit be opened to have access to internal connectors, this must be done at the Laversab facility. If the unit is opened by the user then it may severely impair the hazardous location classification of the unit.

3.2 Mounting the 4100

A suitable mounting bracket may be fabricated by the user based on the user's mounting requirements. Figure 3.1 shows a suggested mounting bracket for mounting the 4100 on a flat plate or on a pipe stand with an optional adapter. The mounting bracket should be fastened to the four mounting studs provided on the rear panel of the unit. The studs are $\frac{3}{4}$ inch in length with a thread size of 5/16 - 18.

WARNING: The mounting bracket should not cover any of the markings and warnings on the rear panel of the 4100.

WARNING: The mounting bracket should not cover any of the connectors or the circuit breakers on the rear panel of the 4100.

WARNING: The mounting bracket should not restrict air-flow between the fins of the top heat-sink.

CAUTION: The mounting bracket should not cover the photo-resistor lens on the front of the 4100.

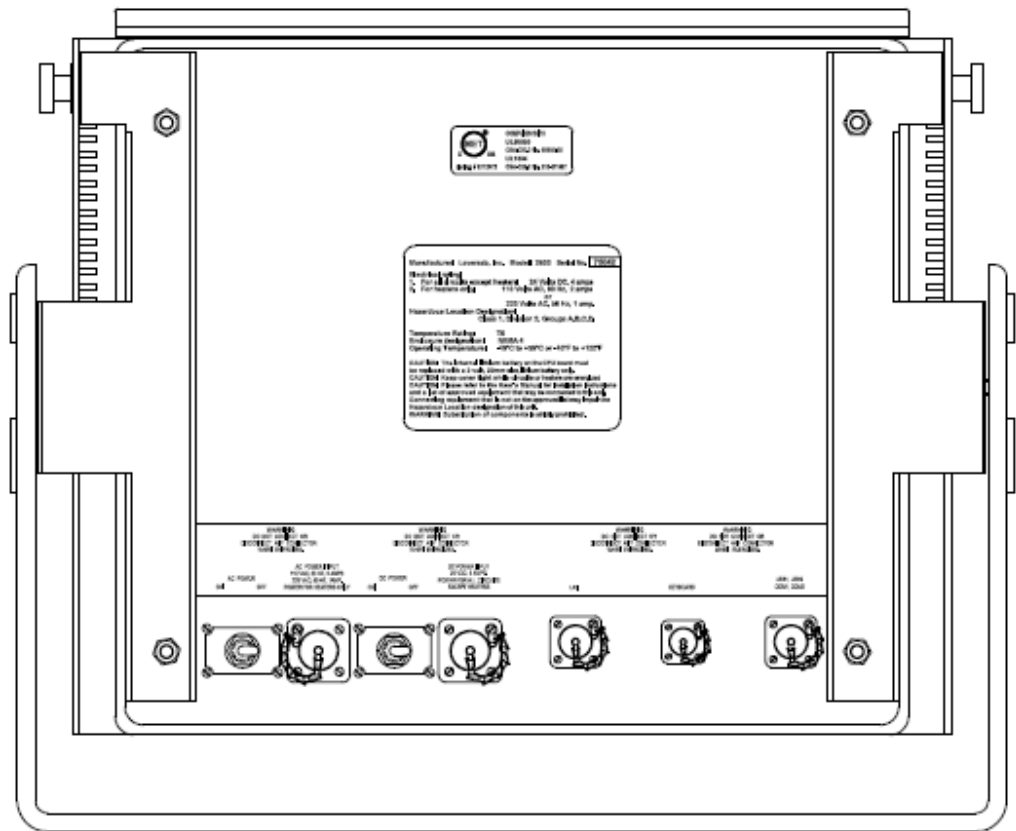
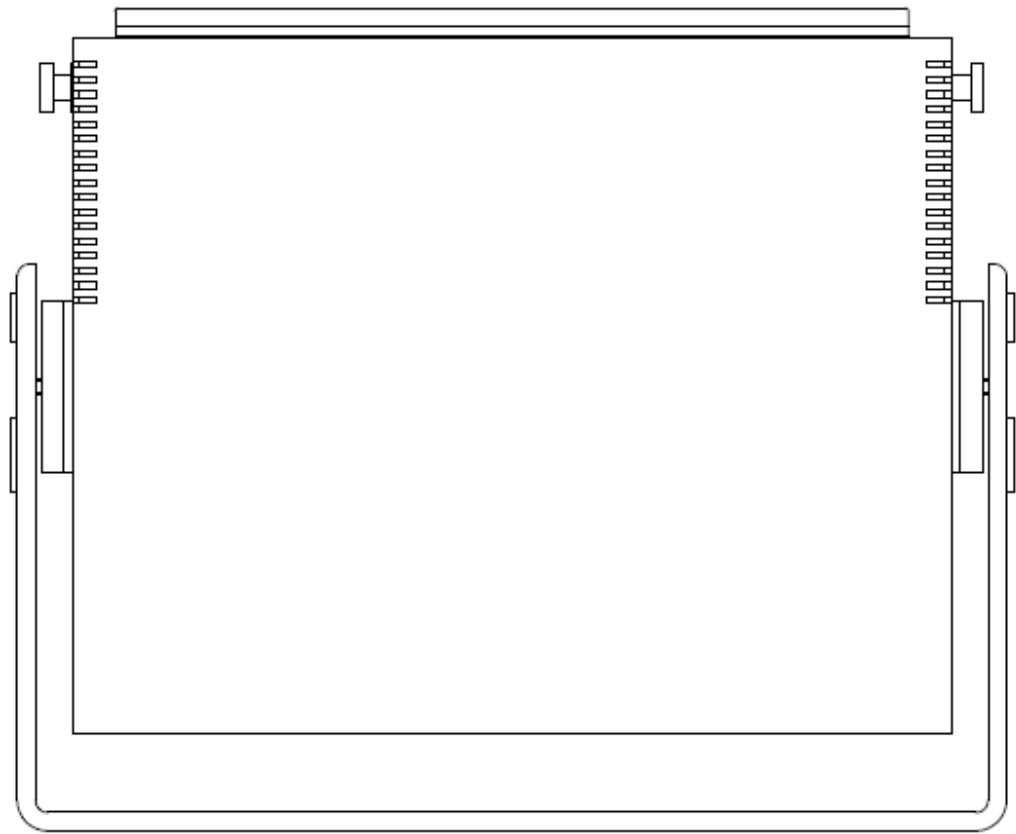
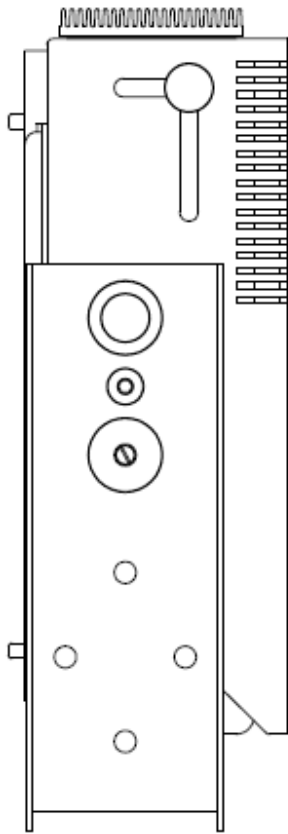

Figure 3.1

3.3 Connections to the 4100

There is a significant difference on how connections may be made to the 4100 based on whether the location of use is hazardous or non-hazardous.

3.3.1 Non-hazardous locations

The unit is provided with the following external cables:

- 1.- AC power cable
- 2.- 1 USB Pigtail
- 3.- 1 PS/2 Keyboard Pigtail
- 4.- LAN cable

WARNING: All the above cables are for use in **non-hazardous locations only**. Using these cables in hazardous locations may impair the hazardous location classification of the unit.

The AC power cable is terminated in a NEMA 5-15 plug and may only be connected to a power source of 110/220 VAC, 50/60 Hz.

The LAN cable is terminated in a standard RJ-45 plug which must be connected to any 10/100 M-bit Ethernet LAN device that adheres to the IEEE 802.3 standard.

The Keyboard cable is terminated in a standard PS2 female connector that may be connected to any standard PS2 keyboard.

The USB cable is terminated in a Type A Jack (4 position) which may be connected to any device with the USB standard ; due to the safety barriers the USB can only support full speed standard (USB 1.1) and since they are current limited, it is recommended to use externally powered devices when possible.

The drawings and pin-outs of these cables are provided in Appendix B.

3.3.2 Hazardous locations

The user is required to provide all the external cables for use in hazardous locations. The cabling and connection methods and restrictions are detailed below. The Control Drawing for all connections to the 4100 is shown in Figure A-1.

1. AC Power cable:

The pin-out for the AC POWER INPUT connector on the rear panel of the 4100 is provided in Appendix A. The mating connector is also listed in Appendix A. The External 110 VAC, 60Hz or 220 VAC, 50 Hz power source must be located in a non-hazardous location.

WARNING: The power cord used must adhere to the following rules:

- a. The power cord must be approved for “extra hard” usage.
- b. The section of the power cord that runs through a hazardous area must be protected by rigid conduit with liquid-tight ends.
- c. Only the last 3 feet before the power cord mates to the 4100 may be left unprotected without the rigid conduit.
- d. The power cord must be terminated into the external AC or DC power source as shown in Figure A-1

WARNING: Make sure that the POWER circuit breaker on the rear panel of the 4100 is in the OFF position before connecting or disconnecting the POWER INPUT connector. Do not connect or disconnect the POWER INPUT connector when the circuits are energized.

WARNING: Ensure that the external power source is OFF before connecting or disconnecting the POWER INPUT connector.

3. LAN cable

The pin-out for the LAN connector on the rear panel of the 4100 is provided in Appendix A. The mating connector is also listed in Appendix A.

WARNING: The LAN cable may only be terminated into a 10/100 M-bit Ethernet LAN device that adheres to the IEEE 802.3 standard. The Control Drawing for this connection is shown in Figure A-1.

A shielded CAT-5 cable may be used to provide this connection to the 4100. Although no special cable protection is required in a hazardous location, it is recommended that the LAN cable be run in the same rigid conduit used for the power cable.

WARNING: Make sure that the POWER and circuit breaker on the rear panel of the 4100 are in the OFF position before connecting or disconnecting the LAN connector. Do not connect or disconnect the LAN connector when the circuits are energized.

4. Keyboard cable

The pin-out for the keyboard connector on the rear panel of the 4100 is provided in Appendix A. The mating connector is also listed in Appendix A.

For details on the keyboard cable, please refer to the Control Drawing shown on Figure A-1.

WARNING: The keyboard cable may be connected only to an intrinsically safe keyboard per the Control Drawing shown in Figure A-1. The recommended keyboard is the model KBM-IS.

WARNING: The keyboard cable must be terminated in a locking connector. The intrinsically safe keyboard must be able to mate to this locking connector.

WARNING: Do not connect or disconnect the keyboard when the circuits are energized. Make sure that the POWER circuit breaker on the rear panel of the 4100 is in the OFF position before connecting or disconnecting the keyboard.

5. USB

WARNING: The USB part of the cable may only be terminated into a connection that adheres to the USB 1.1 standard. The Control Drawing for this connection is shown in Figure A-1.

WARNING: Do not connect or disconnect the USB connector when the circuits are energized. Make sure that the POWER and circuit breaker on the rear panel of the 4100 are in the OFF position before connecting or disconnecting the USB/Serial connector.

A shielded cable may be used to provide the USB connection to the 4100. Although no special cable protection is required in a hazardous location, it is recommended that this communication cable be run in the same rigid conduit used for the power cable.

SECTION 4

TYPICAL USE

After the 4100 has been installed per the instructions provided in Section 3 of this manual, the unit may be turned ON for operation in the following sequence:

1. Turn ON the external power source (AC).
2. Turn ON the devices that provide the Ethernet interfaces in the non-hazardous location.
3. Turn ON the POWER circuit breaker (AC) on the 4100.

If the ambient temperature is below 5°C then the 4100 may not boot up immediately. The internal heaters and fans will start operating and attempt to bring the temperature inside the 4100 above 5°C. While this process is on-going, the heaters LED will turn on indicating that the heaters are operating. The heaters may operate for up to 30 minutes before the internal temperature rises above 5°C, at which point the computer section of the 4100 will boot up.

When the computer section of the 4100 is starting to boot up, the backlight on the display will turn on and the display will be completely white for a period of about 2 to 5 seconds. Thereafter, the boot-up screen will be displayed.

During normal use, the application software will communicate through the LAN and/or the Serial port and show the necessary information on the display. The keyboard may be used as an input device by the user, but typically, the touch-screen and/or the mouse on the front panel, are the only input devices used.

CAUTION: Do not use a sharp object to “touch” the touch-screen. Scratching the touch-screen surface in any way will cause the touch-screen to mal-function.

The mouse on the front panel is configured such that the circular button in the center is the cursor movement button, and the two buttons on either side of it are the left and right click keys. The circular button is pressure sensitive. The harder it is pressed, the faster is the cursor movement.

The mouse and the touch-screen may be used alternately. This means that they are both active at all times and cursor movements and icon selections etc. may be done by either one of them. The “right-click” function on the touch-screen is available and can be configured through the driver application. Cursor movement and icon selection is easier with the touch-screen whereas, “dragging” is easier with the mouse.

If the touch-screen is inoperative, the mouse will still provide the user with input capability. Thereby, the mouse provides redundancy for the touch-screen.

The photo-resistor lens on the front of the unit must be kept un-obstructed and clean during normal operation. This will allow the auto-dimming circuit to properly regulate the brightness of the display based on the ambient light conditions.

WARNING: During normal operation the user must not alter any of the connections to the 4100, including the keyboard connection. Before altering (connecting or disconnecting) any connection, both circuit breakers on the 4100 must be turned OFF so that all internal circuits are de-energized. Failure to do so may create an explosion hazard.

SECTION 5

REMOVAL

While removing (de-installing) the 4100 from normal operation, follow the sequence shown below:

WARNING: Do not disconnect ANY connectors while circuits are energized.

1. Turn OFF the POWER circuit breaker on the 4100.
2. Turn OFF the external power source located in the non-hazardous area.
3. Turn OFF the devices in the non-hazardous area that provide the LAN interface to the 4100.
4. Disconnect the POWER INPUT connector from the 4100.
5. Disconnect the LAN connector.
6. Disconnect the Serial connector.
7. Disconnect the keyboard connector.
8. Remove the 4100 from its mounting stand and move it out of the hazardous location.

WARNING: Not following the above sequence may induce an explosion hazard

SECTION 6

MAINTENANCE & SERVICING

6.1 MAINTENANCE

The only regular maintenance procedures required on the 4100 are:

- a. Clean the touch-screen with water or any commercial window cleaner, using a clean, soft, lint-free cloth. Care must be taken not to scratch the touch-screen during the cleaning process. Do not use any abrasive substance, or any organic solvents to clean the touch-screen.
- b. Clean the photo-resistor lens in the same manner as described in 'a.' above.
- c. Clean the top heat-sink to remove all dirt and foreign objects that may be stuck between the fins of the heat-sink.

WARNING: Do NOT pressure-wash the 4100.

6.2 SERVICING

CAUTION: Risk of explosion if battery is replaced by an incorrect type. Dispose off used batteries in the prescribed manner.

WARNING: Substitution of components is strictly prohibited

WARNING: The Model 4100 does not contain any user-serviceable or user-replaceable components. The 4100 must not be opened by the user in an attempt to repair or service the unit. Doing so may severely impair the hazardous location classification of the unit. All repairs and servicing of the unit can only be performed at the Laversab facility.

SECTION 7

WIRELESS RADIOS

The 4100 model is equipped with a set of two 900 MHz radios; one inside the unit (remote radio) and a second one (master radio) inside the XL-50 Box

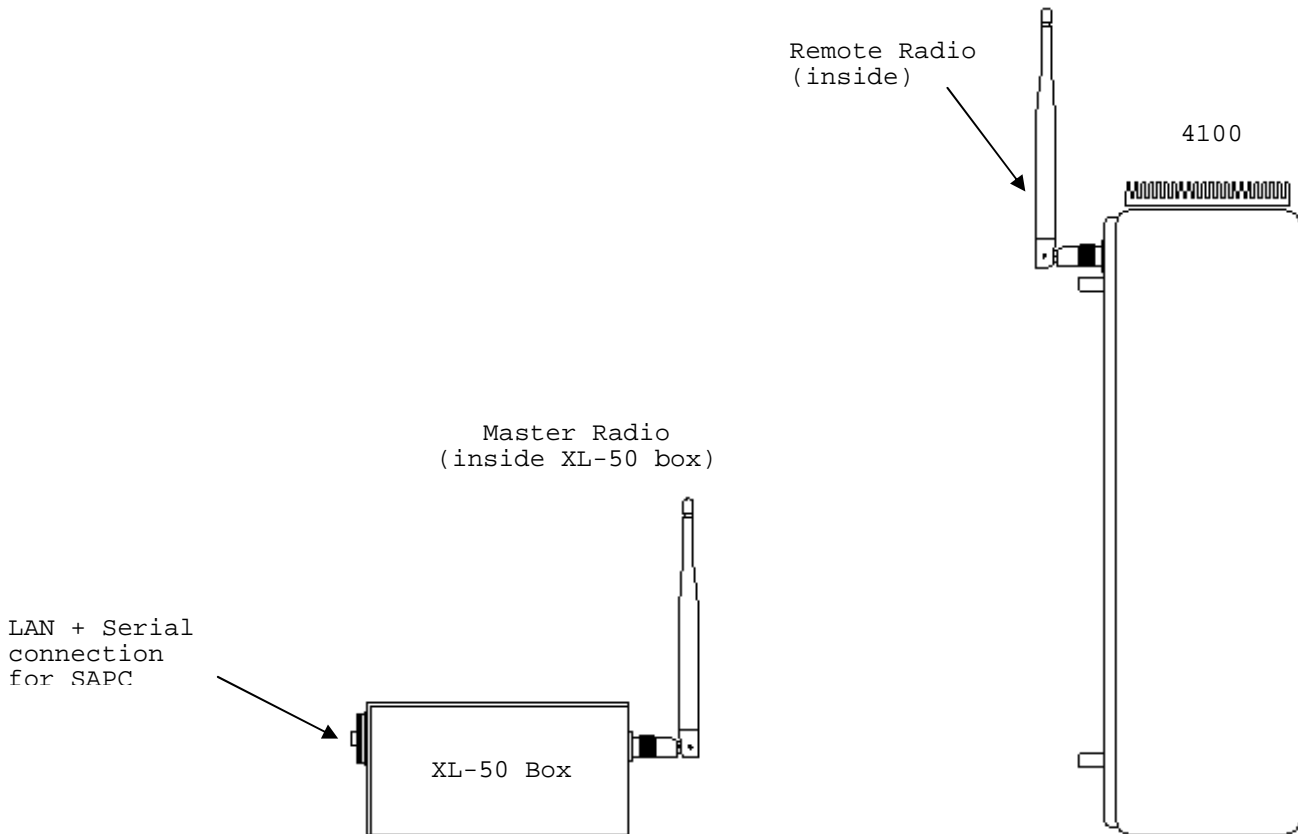

Note: For radio configurations please refer to "Wireless Radio Setup" Manual.

APPENDIX A

EXTERNAL CONNECTIONS (HAZARDOUS / NON HAZARDOUS) LOCATIONS

The external connectors, pin-outs and connection details shown below reference the Control Drawing shown in Figure A-1. Individual connector drawings are shown in Figures A2 through A6.

A.1 MODEL 4100 STANDARD and M2

HAZARDOUS		Interconnect	NON HAZARDOUS	
USB/SERIAL Connector			USB connectors	
CN. Type	ITT Cannon KPT02A14-19S		Conn. Type	Std. USB "A" Socket
Mating	ITT Cannon KPT06J14-19P		Mating	Standard USB A connector
Pin #	Signal		Pin #	Signal
A	N.C.			
B	USB1 +5V		1	+5 V
C	USB1 D-		2	D-
D	USB1 D+		3	D+
E	USB1 GND		4	GND
F	N.C.			
G	N.C.			
H	N.C.			
J	N.C.			
K	N.C.			
L	N.C.			
M	N.C.			
N	N.C.			
P	N.C.			
R	N.C.			
S	XXT RTN			
T	N.C.			
U	N.C.			
V	XXT BUS			

Please refer to **Figure A.1.1-1** and **Figure A.1.2-2**

HAZARDOUS	Interconnect	NON HAZARDOUS
------------------	---------------------	----------------------

LAN Connector 4100	
CN. Type	ITT Cannon KPT02A12-8S
Mating	ITT Cannon KPT06J12-8P

LAN connector	
CN. Type	Standard RJ-45 plug
Mating	Standard RJ-45 socket

Pin #	Signal
A	TD +
B	TD -
C	RD -
D	RD +
E	N.C.
F	N.C.
G	N.C.
H	N.C.

Pin #	Signal
1	TD +
2	TD -
6	RD -
3	RD +
4	N.C.
5	N.C.
7	N.C.
8	N.C.

Please refer to **Figure A.1.1-2** and **Figure A.1.2-3**

HAZARDOUS	Interconnect	NON HAZARDOUS
------------------	---------------------	----------------------

AC Power Input Connector	
CN. Type	B. Harrison 1R3G06A20A120
Mating	B. Harrison 103000A01F060

AC connector	
CN. Type	Std NEMA L6-15 Plug
Mating	Std. NEMA L6-15 socket

Pin #	Signal
G (Green)	Earth Ground
W (White)	Neutral
B (Black)	Line

Pin #	Signal
G	Earth Ground
Y	Neutral
X	Line

Please refer to **Figure A.1.1-4** and **Figure A.1.2-5**

HAZARDOUS	Interconnect	NON HAZARDOUS
------------------	---------------------	----------------------

Keyboard connector	
CN. Type	ITT Cannon KPT02A10-6S
Mating	ITT Cannon KPT06J10-6P

Keyboard connector	
CN. Type	Std. PS2 female connector
Mating	Std. PS2 male connector

Pin #	Signal	Pin #	Signal
A	N.C		N.C
B	KBD CLK	5	KBD CLK
C	KBD DATA	1	KBD DATA
D	KBD GND	3	KBD GND
E	N.C		N.C
F	KBD +5V	4	KBD +5V

Please refer to **Figure A1.1-3** and **Figure A.1.2-1**

A.1.1 Drawings: Back connectors

MODEL 4100 STANDARD

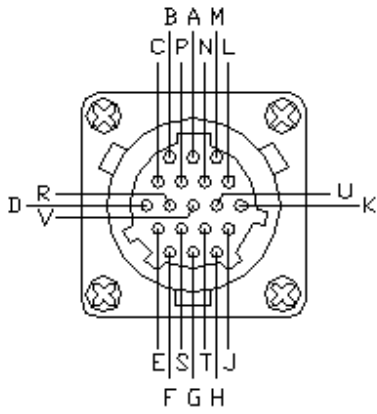

Figure A.1.1-1
USB1
Connector

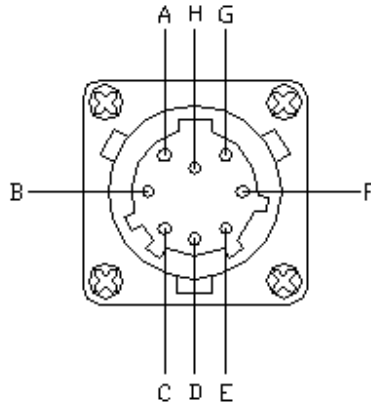

Figure A.1.1-2
LAN connector

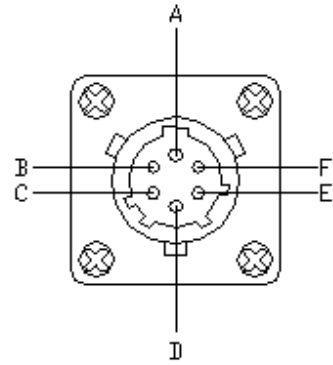

Figure A.1.1-3
Keyboard connector

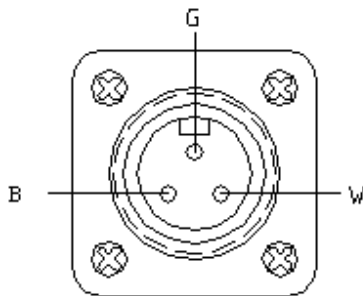

Figure A.1.1-4
AC power input
Connector

A.1.2 Drawings: Cables for Non-Hazardous Locations

MODEL 4100 STANDARD and M2

HAZARDOUS

NON-HAZARDOUS

Mates to keyboard
connector on 4100

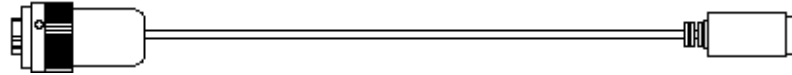

PS2 female
keyboard

Figure A.1.2-1

Mates to USB1 CN. on
4100

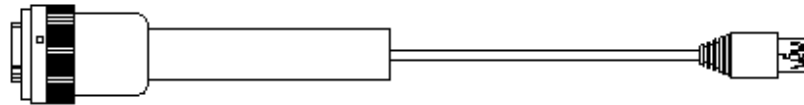

USB 1

Figure A.1.2-2

Mates to LAN
connector
on 4100

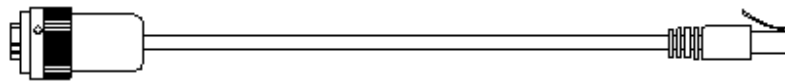

RJ-45 plug

Figure A.1.2-3

Mates to
AC Input
power connector
on 4100

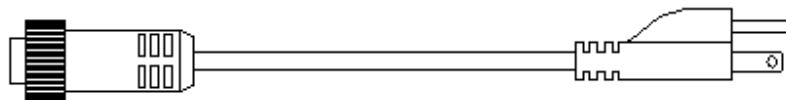

NEMA 5-15

Figure A.1.2-4

A.2: MODEL 4100-M1 and M3

HAZARDOUS	Interconnect	NON HAZARDOUS
------------------	---------------------	----------------------

USB1 Connector	
CN. Type	ITT Cannon KPT02A14-19S
Mating	ITT Cannon KPT06J14-19P
Pin #	Signal
A	N.C.
B	USB1 +5V
C	USB1 D-
D	USB1 D+
E	USB1 GND
F	N.C.
G	N.C.
H	N.C.
J	N.C.
K	N.C.
L	N.C.
M	N.C.
N	N.C.
P	N.C.
R	N.C.
S	N.C.
T	N.C.
U	N.C.
V	N.C.

USB1 connector	
Conn. Type	Std. USB "A" Socket
Mating	Standard USB A connector
Pin #	Signal
1	+5 V
2	D-
3	D+
4	GND

Please refer to **Figure A.2.1-1** and **Figure A.2.2-1**

HAZARDOUS	Interconnect	NON HAZARDOUS
------------------	---------------------	----------------------

LAN Connector	
CN. Type	ITT Cannon KPT02A12-8S
Mating	ITT Cannon KPT06J12-8P

LAN connector	
CN. Type	Standard RJ-45 plug
Mating	Standard RJ-45 socket

Pin #	Signal
A	TD +
B	TD -
C	RD -
D	RD +
E	N.C.
F	N.C.
G	N.C.
H	N.C.

Pin #	Signal
1	TD +
2	TD -
6	RD -
3	RD +
4	N.C.
5	N.C.
7	N.C.
8	N.C.

Please refer to **Figure A.2.1-2** and **Figure A.2.2-3**

HAZARDOUS	Interconnect	NON HAZARDOUS
------------------	---------------------	----------------------

AC Power Input Connector	
CN. Type	B. Harrison 1R3G06A20A120
Mating	B. Harrison 103000A01F060

AC connector	
CN. Type	Std NEMA L6-15 Plug
Mating	Std. NEMA L6-15 socket

Pin #	Signal
G (Green)	Earth Ground
W (White)	Neutral
B (Black)	Line

Pin #	Signal
G	Earth Ground
Y	Neutral
X	Line

Please refer to **Figure A.2.1-4** and **Figure A.2.2-5**

HAZARDOUS	Interconnect	NON HAZARDOUS
------------------	---------------------	----------------------

Keyboard connector	
CN. Type	ITT Cannon KPT02A10-6S
Mating	ITT Cannon KPT06J10-6P

Keyboard connector	
CN. Type	ITT Cannon KPT02A10-6S
Mating	ITT Cannon KPT06J10-6P

Pin #	Signal	Pin #	Signal
A	PRESS TX DRIVE	A	N.C
B	KBD CLK	B	KBD CLK
C	KBD DATA	C	KBD DATA
D	KBD GND	D	KBD GND
E	PRESS TX IN	E	N.C
F	KBD +5V	F	KBD +5V

Please refer to **Figure A.2.1-3** and **Figure A.2.2-1**

A.2.1 Drawings: Back connectors

MODEL 4100-M1 and M3

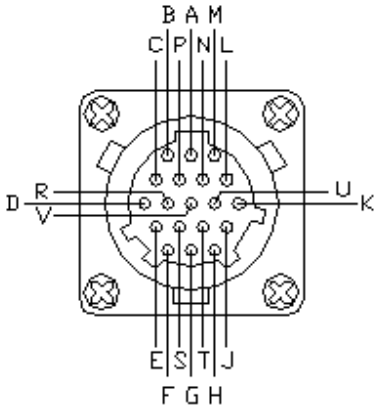

Figure A.2.1-1
USB1
Connector

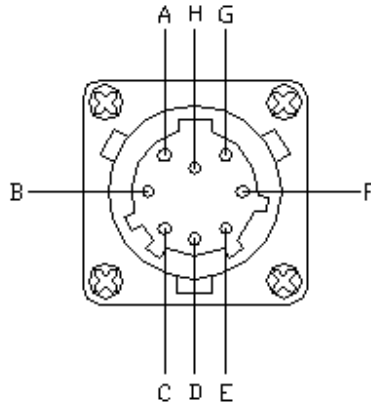

Figure A.2.1-2
LAN connector

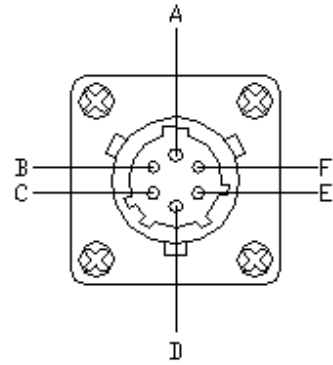

Figure A.2.1-3
Keyboard connector

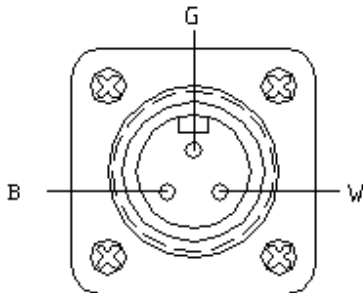

Figure A.2.1-4
AC power input
Connector

A.2.2 Drawings: Cables for Non-Hazardous Locations

MODEL 4100-M1 and M3

HAZARDOUS

NON-HAZARDOUS

Mates to keyboard
connector on 4100

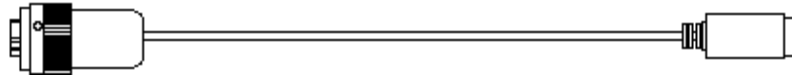

PS2 female
keyboard

Figure A.2.2-1

Mates to USB1 CN. on
4100

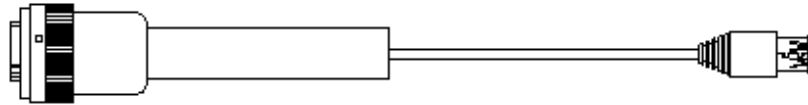

USB 1

Figure A.2.2-2

Mates to LAN
connector
on 4100

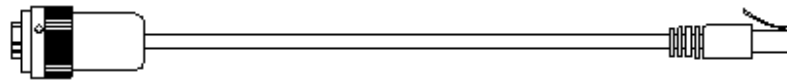

RJ-45 plug

Figure A.2.2-3

Mates to
AC Input
power connector
on 4100

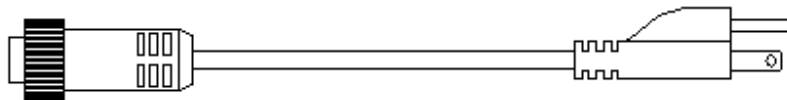

NEMA 5-15

Figure A.2.2-4

APPENDIX B

REPAIR AND RETURN POLICIES

If it is determined that the product is defective, please call Laversab customer service department: (281) 325-8300 or e-mail <oservice@laversab.com> for further assistance.

Before shipping any equipment to Laversab for repair, please call the customer service department at (281) 325-8300 or e-mail to <oservice@laversab.com>. Please include a description of the problem that has been identified when returning defective equipment.

Ship equipment to:

LAVERSAB, INC.
505 Gillingham Lane
Sugar Land, Texas 77478
U.S.A.