

MBM8 / MBM11- Barriers

Installer and User's manual

motorline[®]
PROFESSIONAL

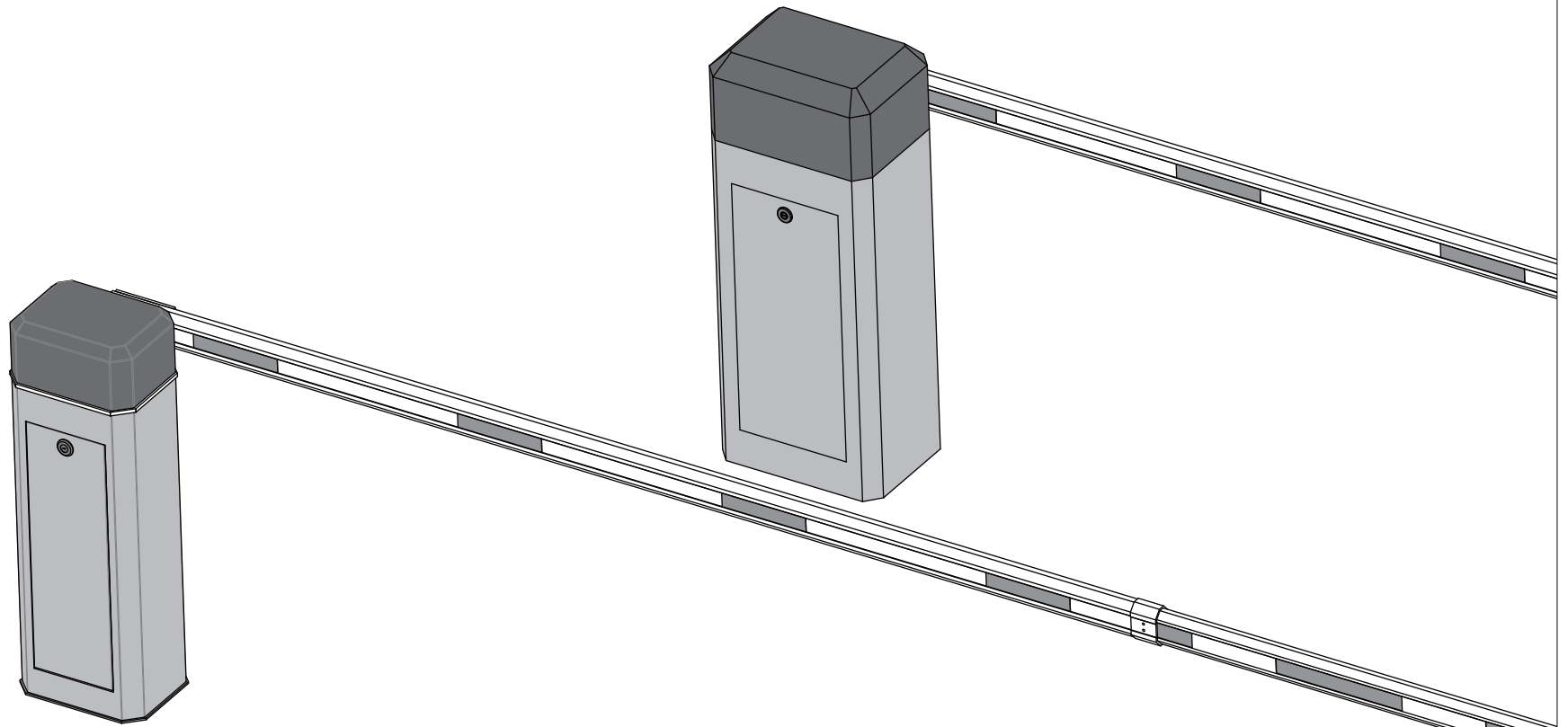

00. CONTENT

▷ INDEX

00. CONTENT

▷ index | page 01.A

01. SAFETY INSTRUCTIONS

▷ standards to follow | page 01.B

02. PACKAGE

▷ inside package | page 02.A

03. THE AUTOMATISM

▷ technical specifications | page 02.B

▷ opening / closing | page 03.A

04. INSTALATION

▷ installation site preparation | page 03.B

▷ barrier's fixation | page 04.B

▷ boom assembly | page 05.A

▷ boom support installation | page 05.A

▷ top cover removal | page 05.B

▷ spring adjustment | page 06.A

▷ boom leveling | page 07.A

▷ limit-switch | page 07.B

05. CONTROL BOARD MC15 CONFIGURATION

▷ checking limit-switches connections | page 08.A

▷ barrier's course configuration | page 08.B

▷ transmitters configuration | page 09.A

▷ pause time configuration | page 09.A

▷ Condominium function and potentiometers | page 09.B

06. TROUBLESHOOTING

▷ final consumers instructions | page 10.A

▷ specialized technicians intructions | page 10.A

07. COMPONENTS TEST

▷ connections scheme | page 11.A

08. MAINTENANCE

▷ maintenance | page 11.B

09. CONTROL BOARD CONNECTIONS

▷ MOTORLINE MC15 control board | page 12.A

01. SAFETY INSTRUCTIONS

STANDARDS TO FOLLOW ◀

ATTENTION:

▷ To ensure the people's safety, it is important that you read all the following instructions. Incorrect installation or incorrect use of the product can cause physical injury and material damage.

▷ Keep these instructions in a safe place for future reference.

▷ This product was designed and produced strictly for the use indicated in this manual. Any other use, not expressly indicated here, could compromise the good condition/operation of the product and/or be a source of danger.

▷ **ELECTROCELOS SA** is not responsible for the improper use of the product, or other use than that for which it was designed.

▷ **ELECTROCELOS SA** is not responsible if safety standards were not taken into account when installing the equipment, or for any deformation that may occur to it.

▷ **ELECTROCELOS SA** is not responsible for the safety and proper operation when using components not sold by them.

▷ Do not make any modifications to the operator components and / or their accessories.

▷ Before installation unplug the automatism from the source of power.

▷ The installer must inform the client how to handle the product in case of emergency and provide this manual to user.

▷ Keep remote controls away from children, to prevent the automated system from being activated involuntarily.

▷ The customer shall not, under any circumstances, attempt to repair or tune the operator. Must call qualified technician only.

▷ Connect the automatism to a 230V plug with ground wire.

▷ Automatism for outdoor use.

O2. PACKAGE

▷ INSIDE PACKAGE

Inside the package you will find the following components:

- ▷ **01** electromechanical barrier
- ▷ **01** MC15 control board
- ▷ **02** 4channel MX4SP transmitter
- ▷ **01** aluminium boom
- ▷ **01** boom support
- ▷ **01** MF3 external photocells set
- ▷ **02** fastening metal plates
- ▷ **01** boom fastening metal plate
- ▷ **04** M16 bolts with bushings
- ▷ **04** boom fastening screws
- ▷ **02** boom support fastening screws
- ▷ **01** boom cover
- ▷ **01** installer and user's manual

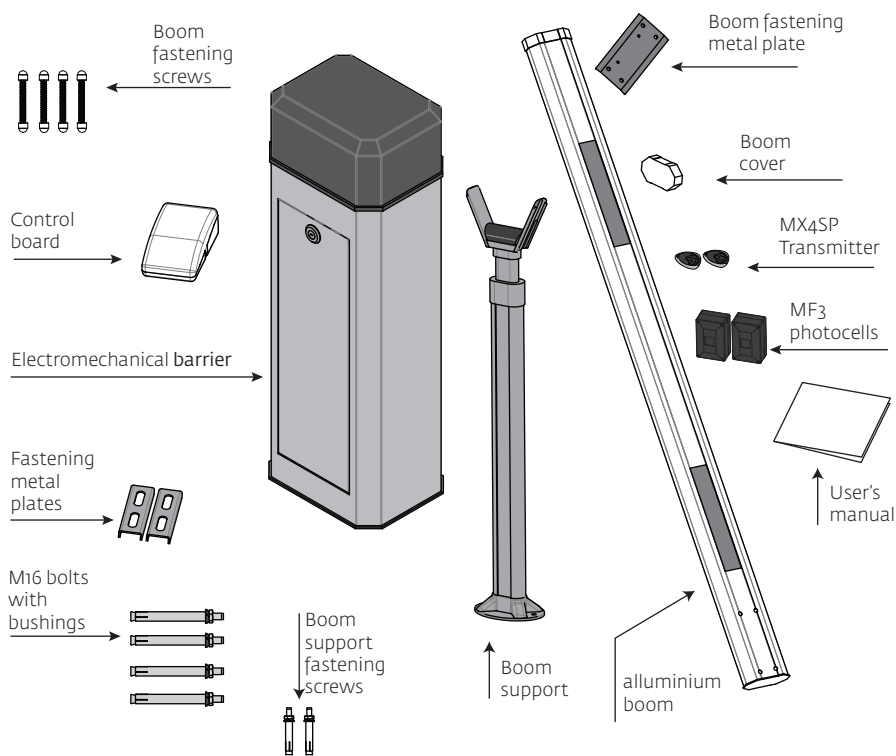

O3. AUTOMATISM

TECHNICAL SPECIFICATIONS ◀

The specifications of the MBM8 and MBM11 barriers are:

	MBM8	MBM11
▷ Barrier's Power Supply	AC 230V 50/60Hz	AC 230V 50/60Hz
▷ Motor's Voltage	AC 230V	AC 230V
▷ Power	180W	300W
▷ Current	1A	2A
▷ RPM	2800 RPM	480 RPM
▷ Noise level	<60 db	<70 db
▷ Working temperature	-45°C to 65°C	-45°C to 65°C
▷ Thermal protection	120°C	140°C
▷ Protection level	IP55	IP55
▷ Working frequency	Intense	Intense
▷ Opening / Closing time	6 s	11 s

The main dimensions of the MBM8 and MBM11 barrier are:

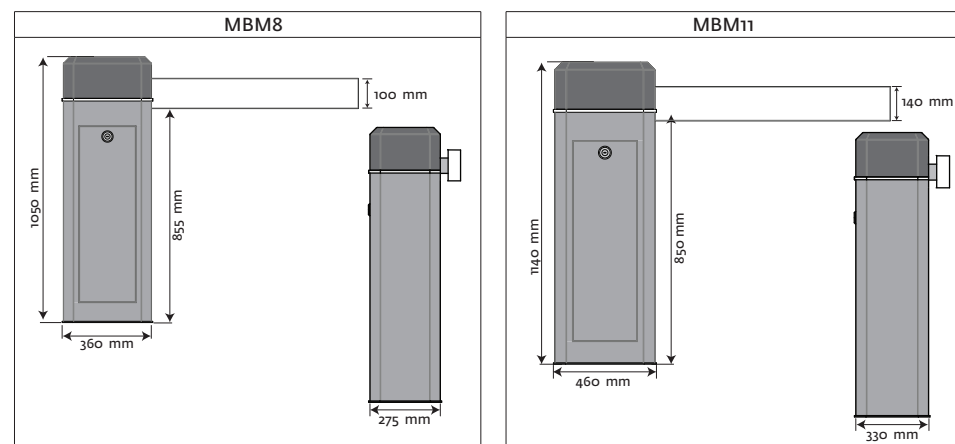

03. AUTOMATISM

▷ OPENING / CLOSING

In case of power failure, the barrier is equipped with a manual unlocking and locking system. Follow the instructions below to unlock or lock the barrier.

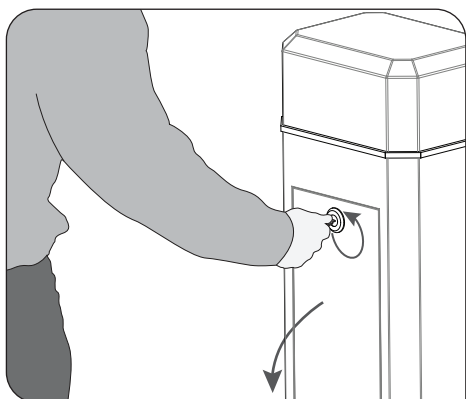

1► Open the door using the key supplied with the barrier. Rotate the key to unlock the door and pull it towards outside. On the interior, you will have access to the unlocking system.

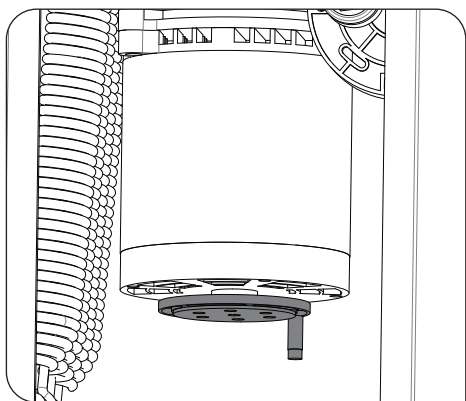

2► The unlocking is made by **rotating the disc** at the bottom of the motor, highlighted/shaded on the image on the side. To open or close you must try to rotate the disk clockwise or counter-clockwise, that depending on the orientation of the barrier (right or left) will open or close the boom.

04. INSTALLATION

INSTALLATION SITE PREPARATION ◀



It's important that this order of installation is respected! Otherwise we can't assure the correct installation of the barrier and it may not work properly.

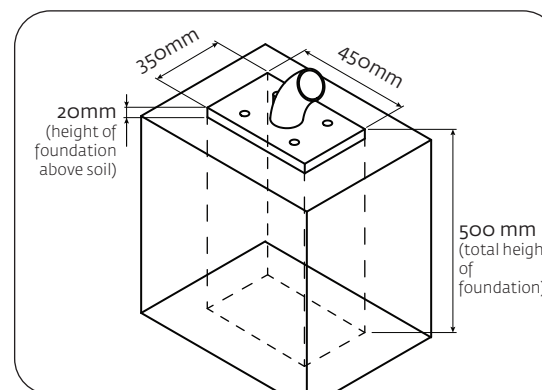

Foundation in cement for MBM8 barrier

1► Create a foundation in cement on the soil. **The dimensions on the side image are the minimum to maintain**, so they can be superior but never inferior. You must leave one or more tubes for the cables of the different components to pass through the foundation to the barrier (photocells, wall starts, key selectors, etc).

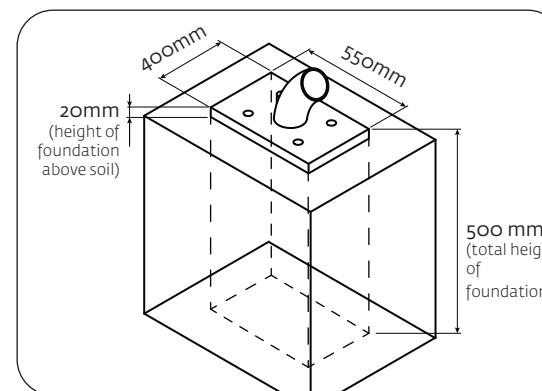

Foundation in cement for MBM11 barrier

04. INSTALLATION

▷ INSTALLATION SITE PREPARATION

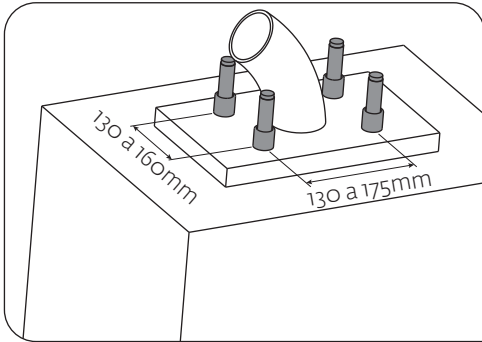

Foundation in cement for MBM8 barrier

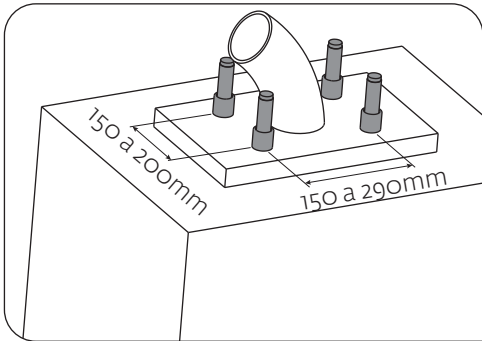

Foundation in cement for MBM11 barrier

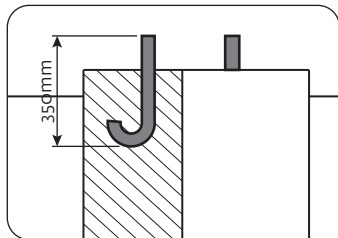

ALTERNATIVE▷ During installation, you can replace the bolts supplied by metal hooks, soldering them on the cement foundation while it is still fresh. You must pay attention to the above image's dimensions when placing the hooks.



To note that each barrier has its own measures to create the holes for the bolts!

04. INSTALLATION

INSTALLATION SITE PREPARATION ◀

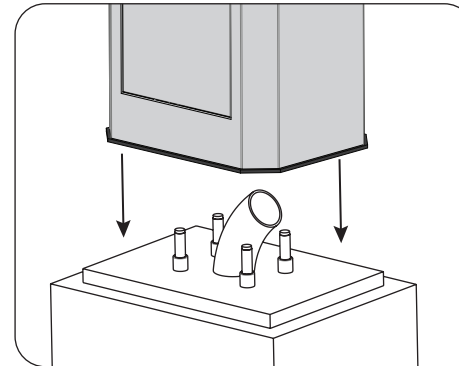

1▷ With the bolts already fixed on the cement foundation, respecting the dimensions of point 2, place the barrier on top of the foundation in a way that the screws stay inside and centered with the barrier.

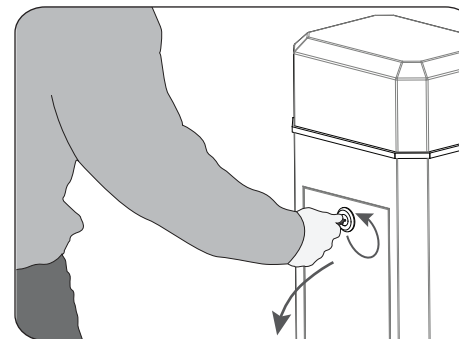

2▷ Open the door using the key to unlock it, and pull it to the outside.

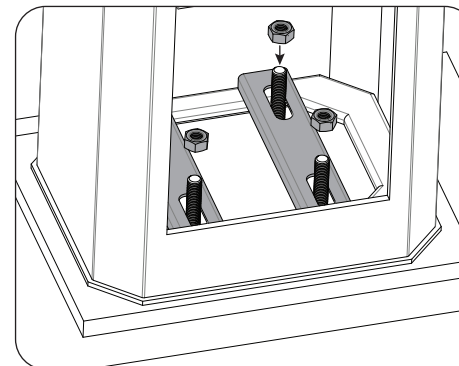

3▷ Place the fastening metal plates and fix the barrier to the ground tightening the nuts supplied with the product.

O4. INSTALLATION

▷ BOOM ASSEMBLY

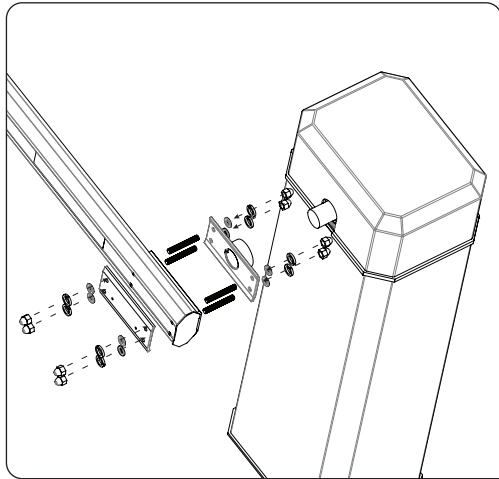

To assemble the boom, you must place the boom on the barrier fixing plate and align the four holes on each piece. Then, you just need to place the boom fastening metal plate and use the screws to fasten the three parts together.

▷ BOOM SUPPORT INSTALLATION

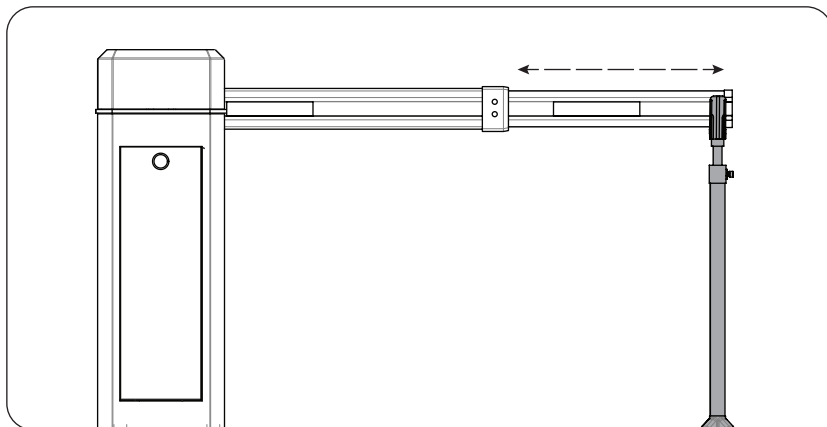

After assembling the boom, you must define the length of it so that you can fix the boom support, as visible on the image above. When the boom's length is decided, fix it with the two small screws situated at the end of the fix part of the boom.

O4. INSTALLATION

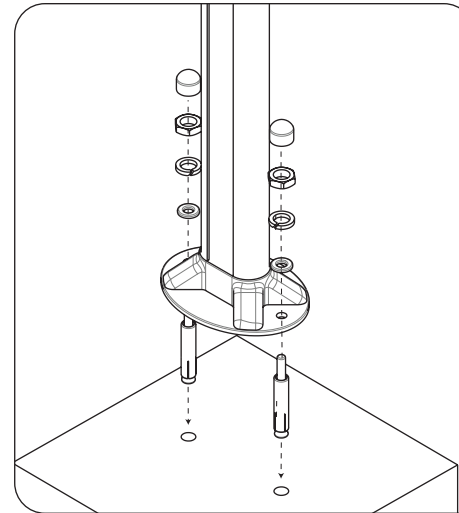

When the position of the boom's support is defined, you can fix it to the ground. Make two holes on the fixing ground, and place the screws supplied. Align the support holes with those same screws and fasten the support using the nuts.

TOP COVER REMOVAL ◀

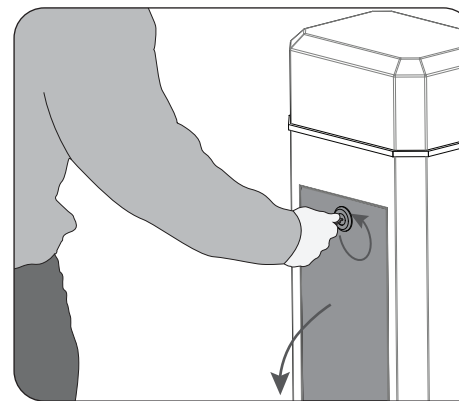

1▶ Open the door using the key supplied to unlock it and then pull it to the outside.

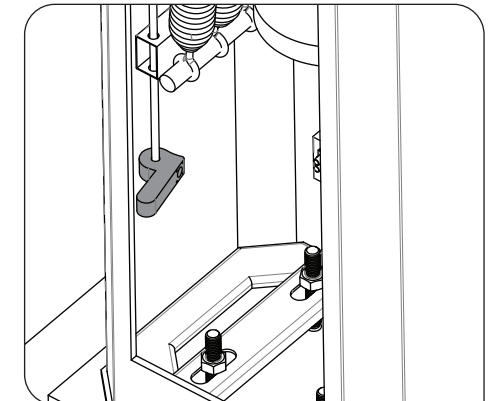

2▶ Rotate the rod (image above) to unlock the cover.

04. INSTALLATION

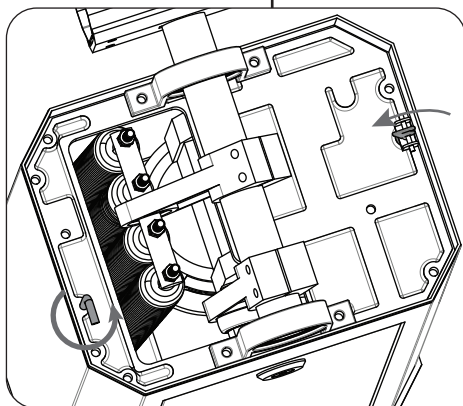

3► The hooks that secure the top cover are also rotated and release the cover.

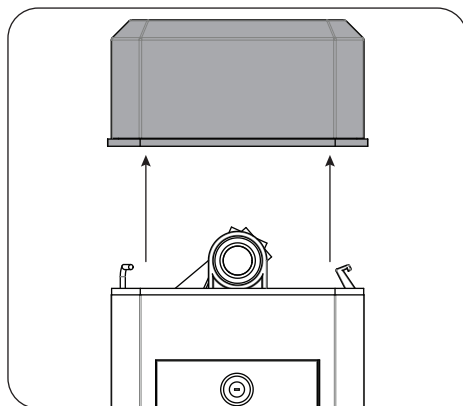

4► Pull the cover up to remove it.

► SPRING ADJUSTMENT

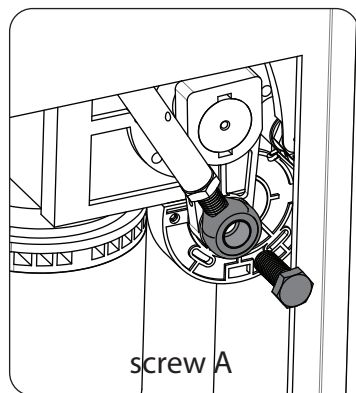

Before starting the tuning of the springs is necessary to remove the screw identified in the illustration.

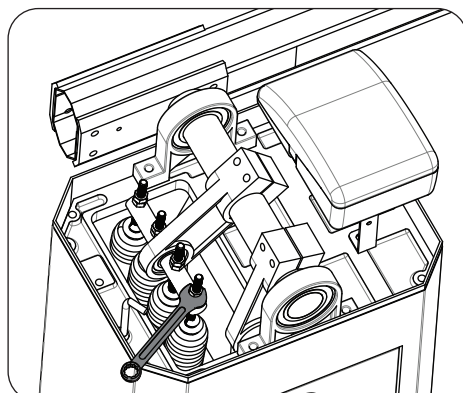

ADJUSTMENT► To adjust the springs, you must use a wrench to fasten or release the springs nuts. If you rotate them clockwise you are giving tension to the springs causing the boom to rise up, and rotating counterclockwise you are removing tension from the springs causing the boom to descend.

06.A

04. INSTALLATION

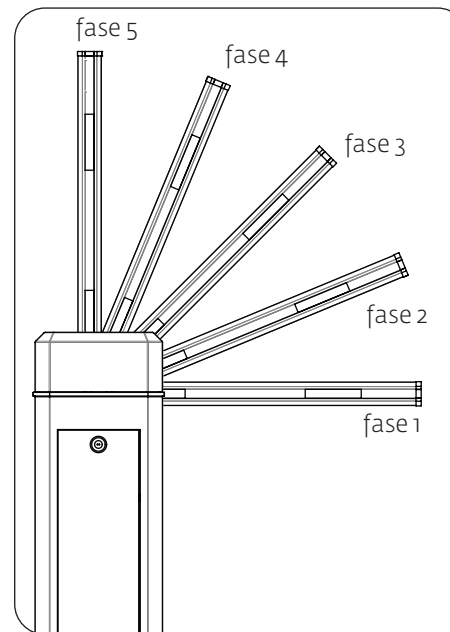

- 1► Remove the screw **A**.
- 2► Put the boom like on **phase 1** as shown on the above image. Let it go and it must maintain on that position, or rising very slowly. If the boom starts to descend or rise adjust the springs until you can make the boom become stabilized.
- 3► Put the boom like on **phase 2, phase 3, phase 4 and phase 5** and repeat the same process of point 2 for each phase. With the adjustment of the springs, you must achieve a stage where you can let go the boom in each position you desire and it must stay stabilized. The springs must be calibrated to sustain the total weight of the boom without the help of the motor.
- 4► Refit the **screw A**.

Barrier MBM8

Boom Length	Number of Springs	Spring's Length and Steel Diameter
6000-7000mm	3	440mm (3 spring's de Ø5mm)
7000-8000mm	3	440mm (2 x Ø 5 + 1 x Ø6mm)
8000mm	4	440mm (3 x Ø5mm + 1 x Ø6mm)

Barrier MBM11

Boom Length	Number of Springs	Spring's Length and Steel Diameter
8000-9000mm	3	440mm (1 x Ø5mm e 2 x Ø6mm)
10000-11000mm	4	440mm (2 x Ø 5 + 2 x Ø6mm)

06.B

04. INSTALLATION

▷ BOOM LEVELING

After installing the barrier, you must verify the position of the boom while closed. If it isn't aligned horizontally when closed, follow the instructions below to adjust it.

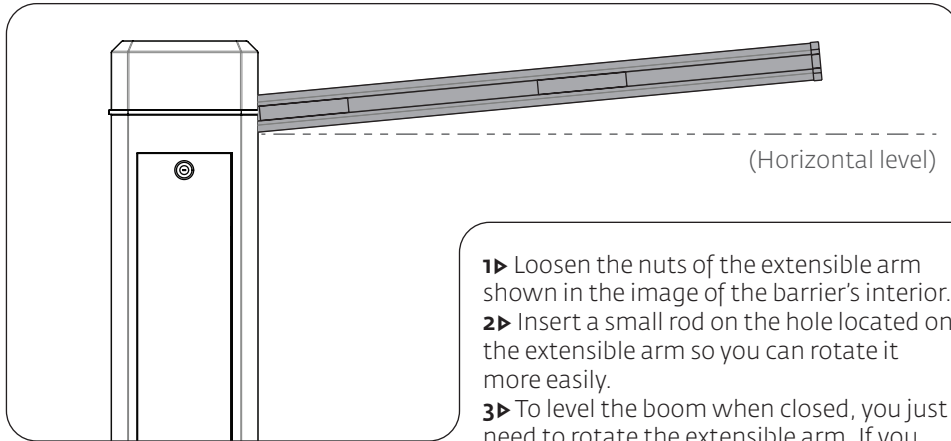

- 1▶** Loosen the nuts of the extensible arm shown in the image of the barrier's interior.
- 2▶** Insert a small rod on the hole located on the extensible arm so you can rotate it more easily.
- 3▶** To level the boom when closed, you just need to rotate the extensible arm. If you rotate to the direction shown by the arrow of the image, you are reducing its size and causing the boom to rise. If you rotate on the other direction, you are increasing its size causing the boom to descend.
- 4▶** When the boom is leveled, you must fasten the nuts of the extensible arm to lock its length. This will prevent the arm to accidentally increase or decrease during the normal usage of the barrier.

NOTE▶ The development of all mechanical parts was made to assure an opening degree of 90° in whatever leveling position you adjust the boom. This means that if you align it horizontally when closed, it will be vertically aligned when opened.

Barrier's interior:

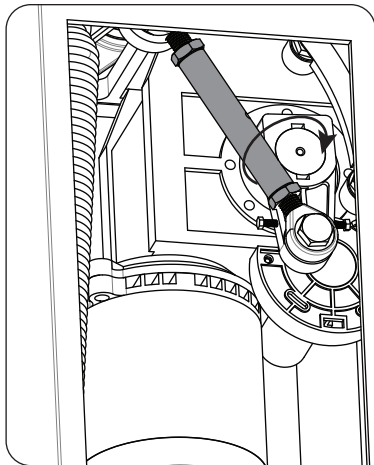

You should disconnect the barrier from the electric power. This way there will be no risk of activating and an accident occurs.

07.A

motorline
PROFESSIONAL

04. INSTALLATION

LIMIT-SWITCHES◀

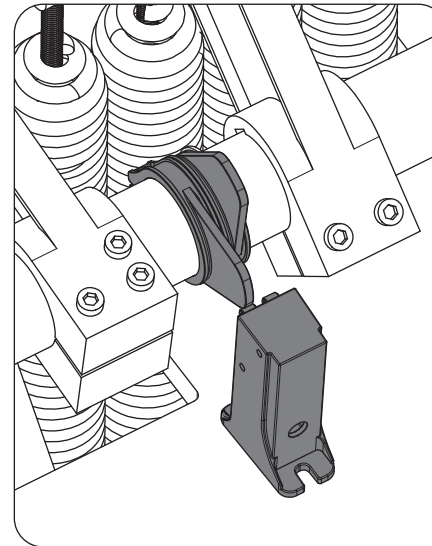

The mechanical limit-switches of the barrier are shown on the image on the left. They consist of two rings fixed to the boom's rotation shaft, that when opening or closing will activate the micro-switches also installed. This will cause the control board to stop the barrier when the micro-switches are activated, one for each type of maneuvers.

Adjust limit-switches:

- 1▶** Slightly loosen the screw of the ring you want to adjust, so it becomes easier to move.
- 2▶** Rotate it to the desired position, so it can activate the micro-switch and stop the boom on the correct position.
- 3▶** Fasten the ring's screw you've adjusted to fix it on that position.

NOTE: When adjusting the limit-switches you must also need to adjust the mechanical stoppers.

The mechanical stoppers shown in the image on the side, were developed to limit the movement of the arms inside the barrier's body.

After adjusting the limit-switches, you must need to adjust the stoppers so that the arm shaded on the image touches them as soon as the micro-switches are activated.

This will cause the stoppers to hold the boom's weight when it gets to end of course.

To make the adjustments, you just need to loosen the bolts that fix them, rotate them and fasten the bolts to fix them on that position.

07.B

05. MC15 CONTROL BOARD CONFIG

▷ CHECKING LIMIT-SWITCHES CONNECTIONS ◀

The **first step** to program the control board is to **verify all connections of the various components**. Please verify the scheme of the connections on the page 12.A

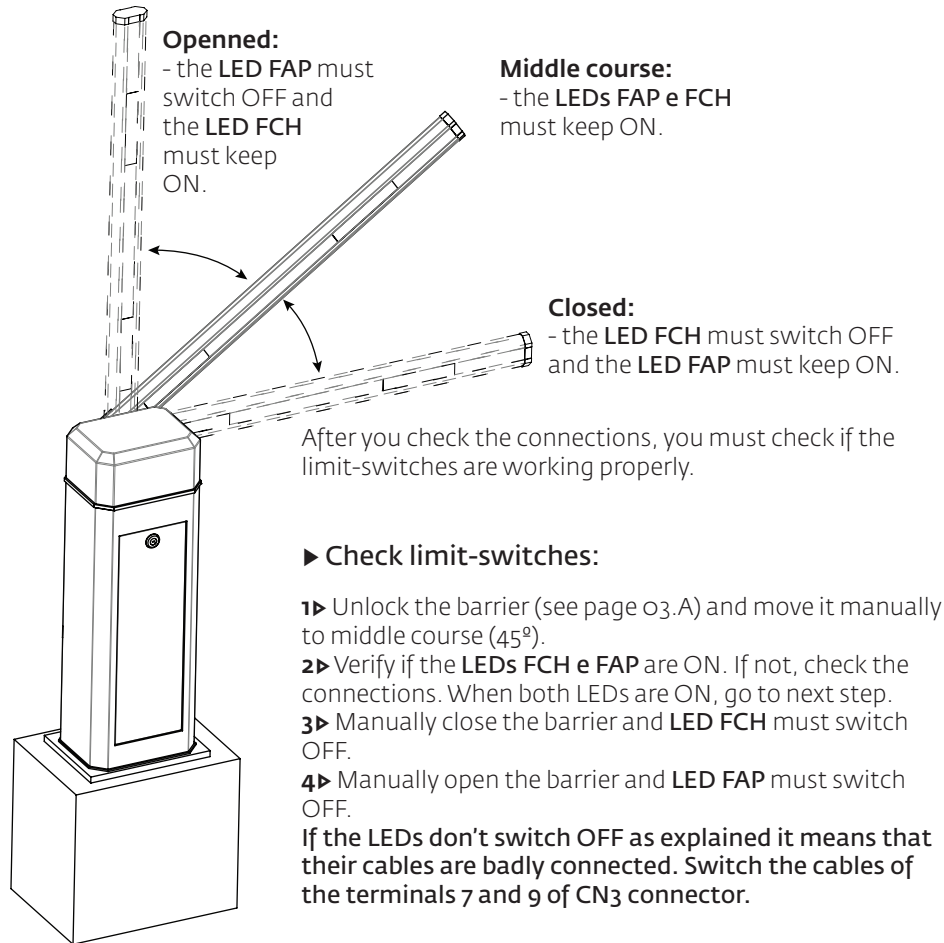

All the programming process must be made with the control board connected to a 230V power supply.

05. MC15 CONTROL BOARD CONFIG

BARRIER'S COURSE CONFIGURATION ◀



The LEDs BL e DS must be both ON so that the barrier can work properly. If they are not, check the connections of the security devices. In case you don't use any security device, please close all circuits with shunts.

You must start the configuration with both potentiometers at middle adjustment. The final adjustment will be made after programming the barrier's course.

► Programming the barrier's course:

- 1► Unlock the barrier (see page 03.A).
- 2► Place the boom manually at middle course and lock the barrier.
- 3► Press the SEL key and the LED CODE will start to blink. Press again the SEL key as many times as you need until the LED PGM AUTO starts blinking.
- 4► Press and hold SET key and the boom **must start to close!**



WARNING: If the boom starts opening, release the SET key, switch the cables of the terminals 5 and 7 of CN2 connector and restart this programming.

- 5► Let the barrier **close, open and close once again automatically**, always keeping the SET key pressed.
- 6► Once the barrier finishes closing for the second time, the LED PGM AUTO will stay ON permanently and the LED T.MOTOR will start to blink. Release SET key and wait 10seconds until the LED T.MOTOR stops from blinking.
- 7► The programming is now complete and you can use the barrier normally.

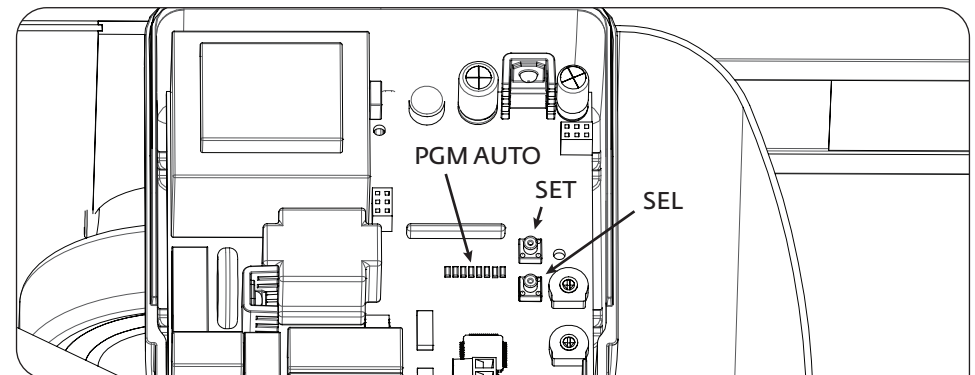

05. MC15 CONTROL BOARD CONFIG

▷ TRANSMITTERS CONFIGURATION

Once you have the barrier's course configured, you can now program the transmitters:

► Programming transmitters:

- 1► Press the **SEL** key once and the **LED CODE** will start blinking.
- 2► Press the transmitter key once if you want to operate the barrier.
- 3► When pressing the transmitter key, the **LED CODE** must turn and stay **ON** signaling the success of the configuration.
If the LED CODE doesn't stay ON, the transmitter was not programmed. Please repeat the same steps to try once again.

NOTE: To program several transmitters, repeat the same steps above for each one of the transmitters.

▷ PAUSE TIME CONFIGURATION

The **pause time** is the time that the barriers stays paused since it completes the opening maneuver until it starts to close automatically.

► Programming the pause time in automatic mode:

- 1► Press the **SEL** key once and the **LED CODE** will start blinking. Press again the **SET** key as many times as you need until the **LED T.PAUSA** starts blinking.
- 2► Press **SET** once and wait as much time as you want for pause time.
- 3► Press **SET** once and the pause time is defined.

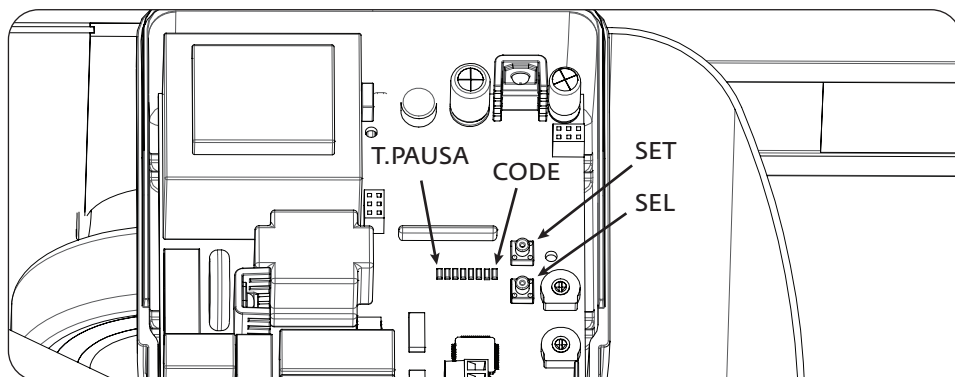

09.A

05. MC15 CONTROL BOARD CONFIG

CONDOMINIUM FUNCTION AND POTENTIOMETERS ◀

The condominium function of this control board causes the barrier to **only accept opening orders**. When the barrier is closed, if you press the transmitter's key to open, it will start opening, but during the opening maneuver or when it is already opened, if you try to close it, the control board won't accept it. This causes the barrier to only close automatically.

► Activate and deactivate condominium function:

- 1► Press the **SEL** key and the **LED CODE** will start blinking. Press again the **SET** key as many times as you need until the **LED CMD AP** starts blinking.
- 2► Press **SET** to confirm.
- 3► If the **LED CMD AP** stays **ON** it means that the function is activated, and if it stays **OFF** it means that the function is deactivated.

► Adjust sensibility and force potentiometers:

The force potentiometer controls the force of the motor when opening and closing. **The sensibility potentiometer** controls the sensibility of the control board when detecting obstacles. The more sensitive it is the quicker it will detect any obstacle during its course and invert the orientation of working of the motor.

- 1► To adjust potentiometers, run them with a small screwdriver. Turning to the right side, will increase and turning to the left will decrease.

NOTE: Everytime you make an adjustment to the force potentiometer, you must perform a new barrier's course configuration (see page 08.B).

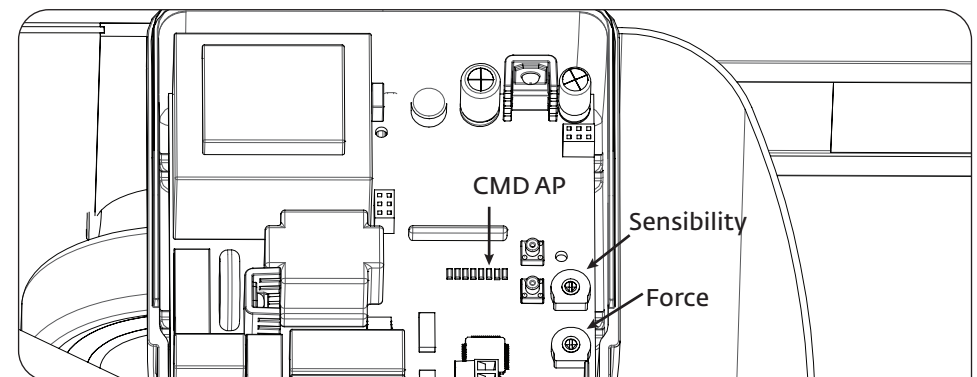

09.B

06. TROUBLESHOOTING

▷ INSTRUCTIONS FOR FINAL USERS

INSTRUCTIONS FOR INSTALLERS ◀

Anomaly	Procedure	Behavior	Procedure II	Discovering the origin of the problem			
▷ Barrier doesn't work	▷ Make sure you have 230V power supply connected to operator and if it is working properly.	▷ Still not working	▷ Consult a qualified MOTORLINE technician.	1 ▷ Open control box and check if it has 230V power supply; 2 ▷ Check input fuses;	3 ▷ Disconnect barrier from control board and test them by connecting directly to power supply in order to find out if they have problems (see page 11.A).	4 ▷ If the barrier works, the problem is on the control board. Pull it out and send it to our MOTORLINE technical services for diagnosis;	5 ▷ If the barrier doesn't work, remove them from installation site and send to our MOTORLINE technical services for diagnosis.
▷ Barrier doesn't move but makes noise	▷ Unlock barrier and move boom by hand to check for mechanical problems on the movement.	▷ Encountered problems?	▷ Consult a qualified MOTORLINE technician.	1 ▷ Check all motion axis and associated motion systems related with the barrier to find out what is the problem.			
		▷ Boom moves easily?	▷ Consult a qualified MOTORLINE technician.	1 ▷ Check capacitors, testing operator with new capacitor; 2 ▷ If capacitors are not the problem, disconnect motor from control board and it them by connecting directly to power supply in order to find out if it has problems (see page 11.A).	3 ▷ If the motor works, the problem is from control board. Pull it out and send it to our MOTORLINE technical services for diagnosis;	4 ▷ If the motor doesn't work, remove them from installation site and send to our MOTORLINE technical services for diagnosis.	
▷ Barrier opens but doesn't close	▷ Unlock motor and move boom by hand to closed position. Lock motor again and turn off power supply for 5 seconds. Reconnect it and send order to open barrier using transmitter.	▷ Barrier opened but didn't close again	1 ▷ Check if there is any obstacle in front of the photocells; 2 ▷ Check if any of the control devices (key selector, push button, video intercom, etc.) of the barrier are jammed and sending permanent signal to control unit; 3 ▷ Consult a qualified MOTORLINE technician.	All MOTORLINE control boards have LEDs that easily allow to conclude which devices are with anomalies. All safety devices LEDs (DS) in normal situations remain On. All "START" circuits LEDs in normal situations remain Off. If LEDs devices are not all On, there is some security systems malfunction (photocells, safety edges), etc. If "START" circuits LEDs are turn On, there is a control device sending permanent signal.	A) SECURITY SYSTEMS: 1 ▷ Close with a shunt all safety systems on the control board (check manual of the control board in question). If the automated system starts working normally check for the problematic device. 2 ▷ Remove one shunt at a time until you find the malfunction device . 3 ▷ Replace it for a functional device and check if the motor works correctly with all the other devices. If you find another one defective, follow the same steps until you find all the problems.	B) START SYSTEMS: 1 ▷ Disconnect all wires from START terminal input (terminal 3 of CN3 connector). 2 ▷ If the LED turned Off, try reconnecting one device at a time until you find the defective device. NOTE: In case procedures described in sections A) and B) don't result, remove control board and send to our technical services for diagnosis.	
▷ Barrier doesn't make complete route	▷ Unlock barrier and move boom by hand to check for mechanical problems on the barrier.	▷ Encountered problems?	▷ Consult a qualified MOTORLINE technician.	1 ▷ Check all motion axis and associated motion systems related with the barrier to find out what is the problem.			
		▷ Boom moves easily?	▷ Consult a qualified MOTORLINE technician.	1 ▷ Check capacitors, testing with new capacitors; 2 ▷ If capacitors are not the problem, disconnect motor from control board and test it by connecting directly to power supply in order to find out if it is broken; 3 ▷ If the motor doesn't work, remove it from installation site and send to our MOTORLINE technical services for diagnosis.	4 ▷ If motor work well and move barrier at full force during the entire course, the problem is from the controller. Set force using trimmer on the board. Make a new working time programming, giving sufficient time for opening and closing with appropriate force (page 08.B of this manual for MBM8/MBM11	230V). 5 ▷ If this doesn't work, remove control unit and send it to MOTORLINE technical services.	NOTE: Setting force of the controller should be sufficient to make the barrier open and close without stopping, but should stop and invert with a little effort from a person. In case of safety systems failure, the barrier shall never cause physical damaged to obstacles (vehicles, people, etc.).

07. COMPONENT TEST

▷ CONNECTIONS SCHEME

To detect which are the components with problems in barrier's installation, sometimes it will be needed to run some tests with direct connection to a 230V power supply. For that, it's necessary to interpolate a 16 μ F capacitor in between the connection for the barrier to operate.

At the bellow scheme, it's shown how the connection must be done interpolating the different device's cables.

NOTES:

▷ To run the test you don't need to remove the barrier from the installation site where it is installed. This way you can more easily find out if the barrier, connected directly to the power supply, works properly.

▷ The order to connect the capacitor's cables on the barrier's cables is not important. You just have to connect one on the **Brown** cable and the other on the **Black** cable.

▷ The common cable of the barrier must always be connected to the power supply.

▷ To invert the operating direction, you just need to change the **Black** cable with the **Brown** cable of the barrier, on the connection to the power supply.

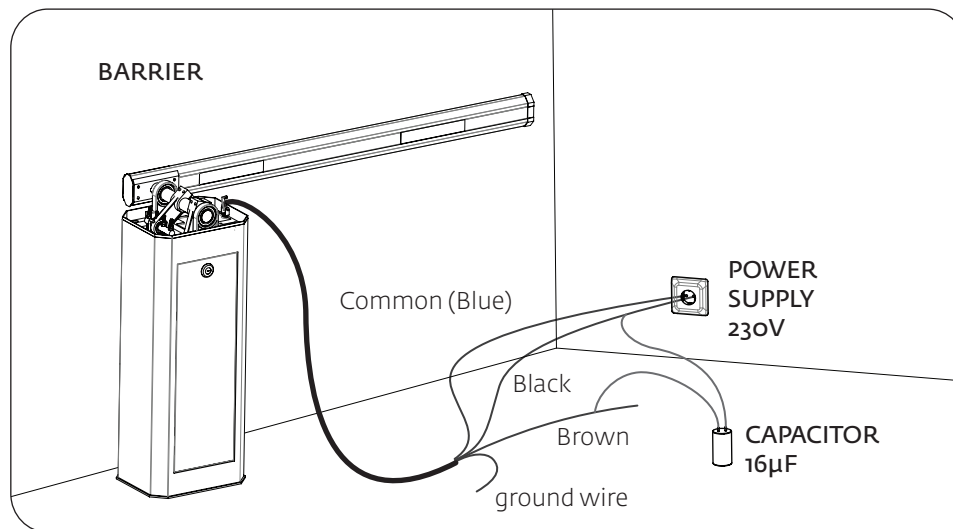

IMPORTANT: All tests must be made by qualified technicians due to the serious danger related to the incorrect use of electronic systems!!

08. MAINTENANCE

MAINTENANCE ◀

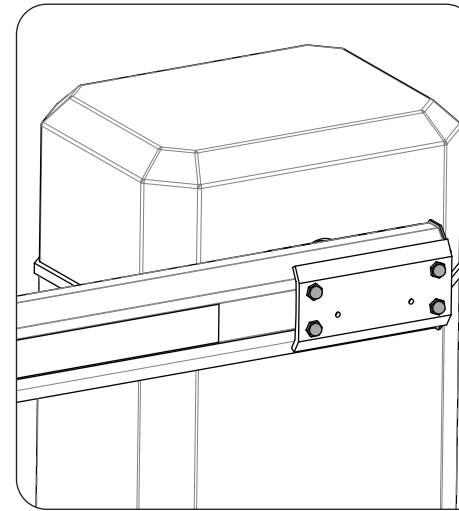

Check tightness of the screws that fix the boom to the barrier's body.

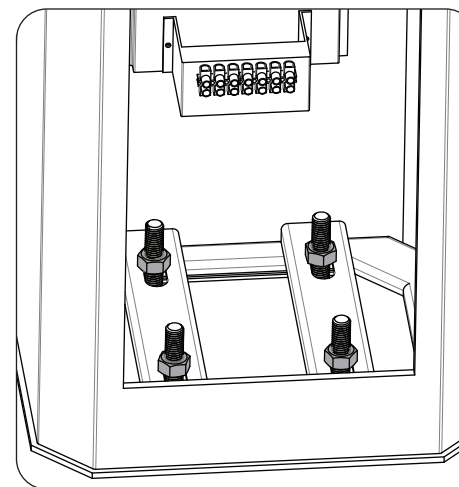

Check if the fastening metal plates didn't suffer any modification with the consistent utilization to assure the proper functioning of the barrier.



These maintenance procedures must be realized every year to assure the well functioning of the automatism.

09. CONTROL BOARD CONNECTIONS

▷ CENTRAL MC15 MOTORLINE

