

GST-IFP8 USER MANUAL



Notice

This instructions covered in this manual have been carefully checked for accuracy and are presumed to be correct. However, the manufacturer assumes no responsibility for inaccuracies and reserves the right to modify and revise this document without notice.

This manual covers the installation, programming and commission of the GST IFP8 Fire Alarm Control Panels.

Contents

Preface EN 54 Information	4
Introduction	5
Installation	6
System Lay-out	8
Main Power Lay-out	9
Main Control Board	10
Terminal Connection	10
Device Addressing	11
Control Panel and Indication	13
Description of Controls	14
Zone Indication Panel	15
System Commissioning	16
Commission Mode	16
How to register a devices/Auto Learn	16
How to check duplicated address and device mismatch	17
How to modify the device address	17
How to modify the device sensitivity	18
System Programming	19
How to program the device detail.....	19
How to encode the text	19
How to program the zone.....	20
How to program the equation.....	21
How to edit the device type	22
System Browsing	23
To view the device detailed	23
To view the zone (INPUT) assignment.....	24
To view the group (OUTPUT) assignment	24
To view the duplicated address	25
To view the panel status.....	25
To view the C&E Equation	25
To view the system history	26
SET-UP OPTION	26
To set-up the clock	26
To set-up the printer	26
To set-up the delay mode.....	26
To set-up the local outputs	27
SYSTEM OPERATION	28
Dependency Mode/ Pre-alarm	28
Test Mode	29
START/STOP OPTION	29
DISABLE/ENABLE OPTION	30
Maintenance	31
System Menu	32
Lists of Device Type and Condition	36
Appendix 4	38
Operation Following an Alarm or Fault Condition	39

Preface EN 54 Information

The GST IFP8 is an Intelligent Fire Alarm Control Panel complies with the latest requirement of EN standard.

GST-IFP8 Intelligent Fire Alarm Control Panel (FACP) complies with the requirements of EN 54-2 1997 + A1: 2006 and EN 54-4 1997 + A1: 2002 + A2: 2006.

Option		EN 54-2 Clause
Indication	Alarm counter	7.13
	Fault signals from points	8.3
Control	Delays to outputs	7.11
	Dependencies on more than one alarm signal	7.12
	Disabling of addressable points	9.5
Outputs	Output to fire alarm devices	7.8
	Control of fire alarm routing equipment	7.9
	Output to fire protection equipment	7.10
Test	Test condition	10

The power supply of GST-IFP8 FACP complies with EN 54-4 requirements.

	EN 54-4 Clause
Power supply from the main power source	5.1
Power supply from the standby power source (battery)	5.2
Charger	5.3
Faults	5.4

In addition to functions required by EN54-2, the panel supports a number of ancillary functions that are not required. These are outlined below:

Ancillary Function	Manual Section
SP-E32PK Printer	3.2.2
RS232/USB Output	2.3 & 3.2.2
GST852RP Repeater Panel	3.3.6
GstDef2.1 Defining Tool	3.4
Fire Alarm Output	4.4.3.3
RS485 Output	2.3 & 4.4.3.5

Introduction

The GST-IFP8 is an intelligent fire alarm control panel. Flush-mounted type housing it provides the perfect solution for all medium to large system by utilizing advance GST Protocol.

The system is compatible with the complete range of GST Intelligent detectors, Sounders, Call Points, and Interfaces, including intrinsically safe and gaseous extinguishing control. IFP8 is manufactured and certified to EN54 parts 2 and 4 and to BS5839 Par 4.

8 x Loops (242) capacity (1936) addressable points

Maximum 10 Loops Standalone

Modular constructed for future expansion

40 x15 lines Colour Graphical LCD Display.

Up to 999 programmable zones and 140 zone indication

Auto Programming Day and Night Mode

Enable and Disable function

PAS and Acknowledge Function

Dirty Detector Reporting

Duplicate Address Checking

Walk Test Function with optional silent mode

Can edit device detailed and programmed

Programmable form PC or Panel

History record-999 fire incident only and 999 event capacity in non-volatile memory Fully simulation of Cause and Effect

Advanced user friendly programming software including 'Fuzzy Logic'.

Networked with all GST Intelligent Fire panels up to 99 Nodes, Optional Fiber Optic and LAN Network Interface.

RS 485 mimic and repeater output up 64

RS 232-USB CRT interface, including GSTGMC graphic

Built in Fire Alarm, FPE, Fault and Alarm Router output

Panel Printer included

Built in Battery charger.

Installation

Installation of the panel should be carried out by trained personnel only. The electronic components inside the panel are vulnerable to damage by electrostatic discharges. It is recommended to wear a wrist strap designed to prevent the build-up of static charges within the body, before handling any electronic circuit boards.

Before unpacking anything, please review all the manual and drawing.

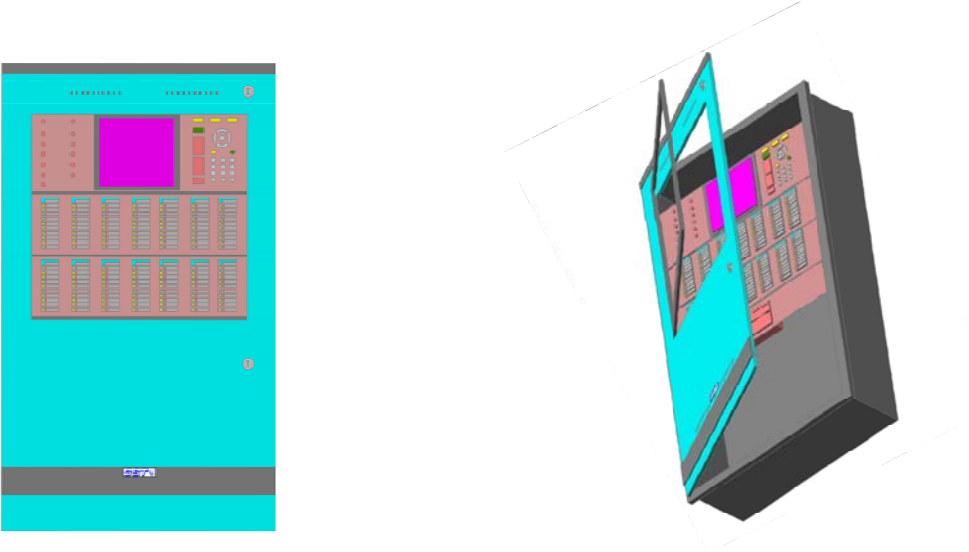

Open the IFP8 Control Panel, unlock and prop the hinged door.

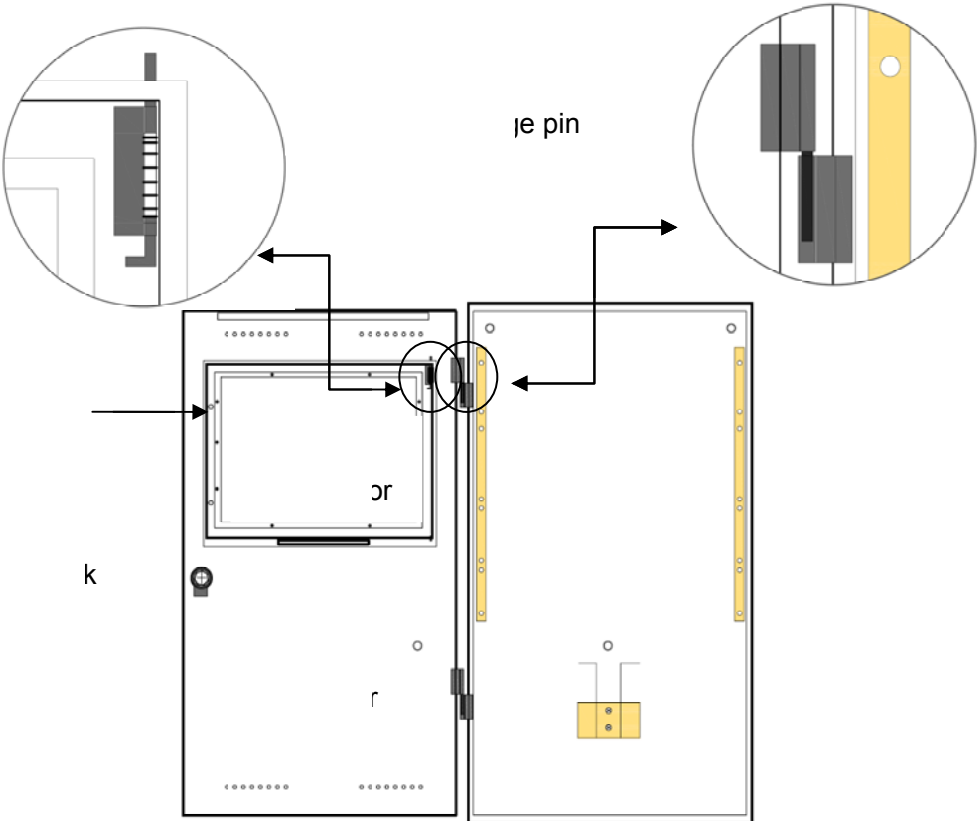

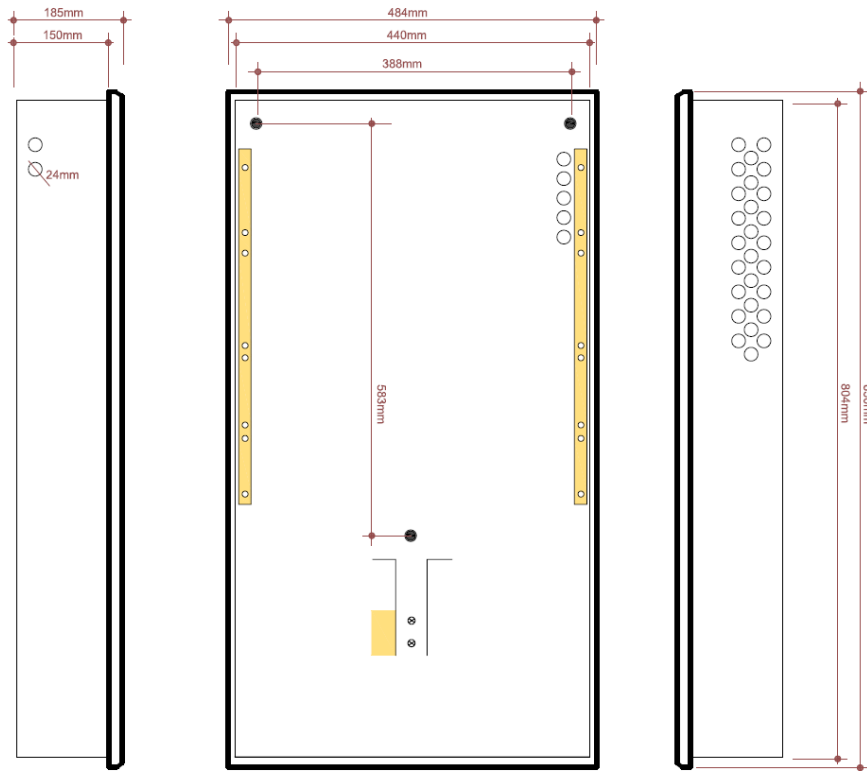
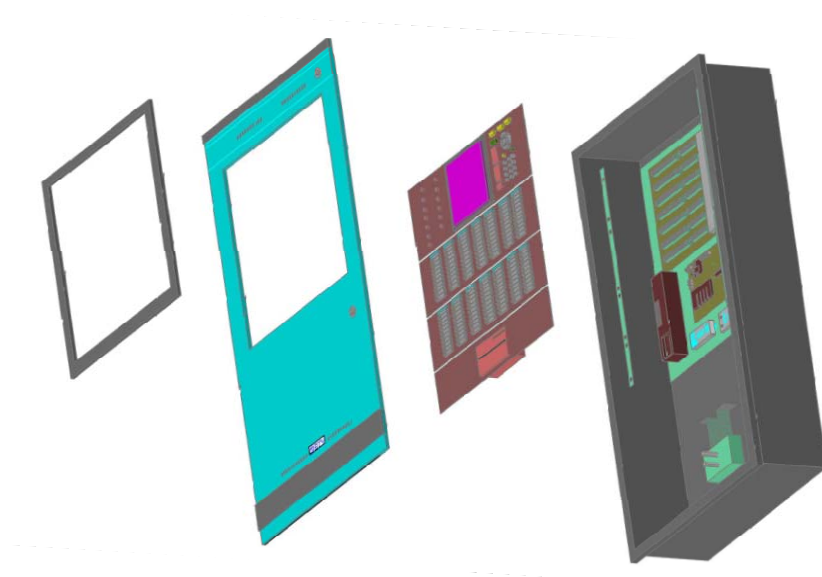

Locate and placed the panel and marked the three holes for mounting.

System Lay-out

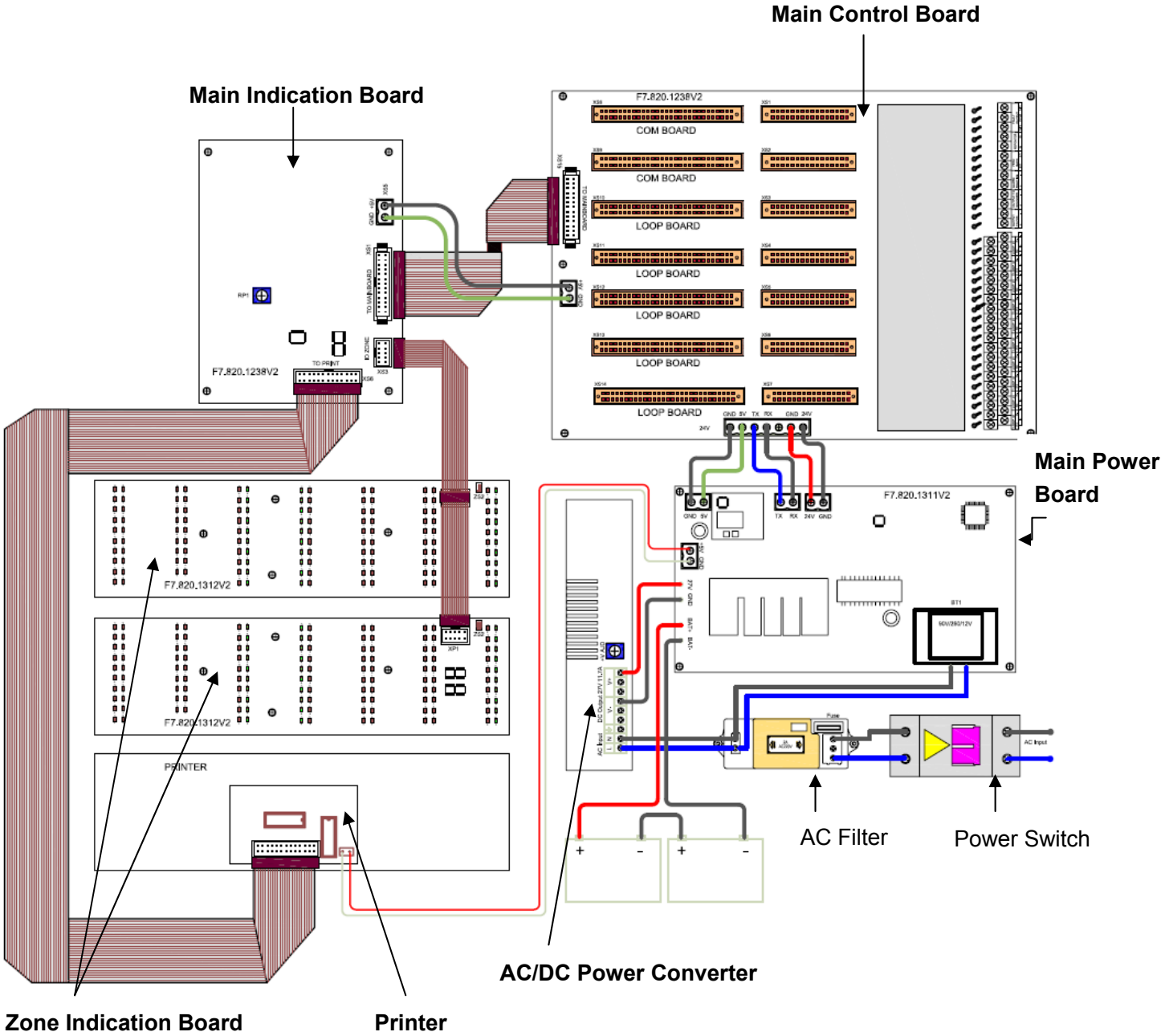

Main Power Lay-out

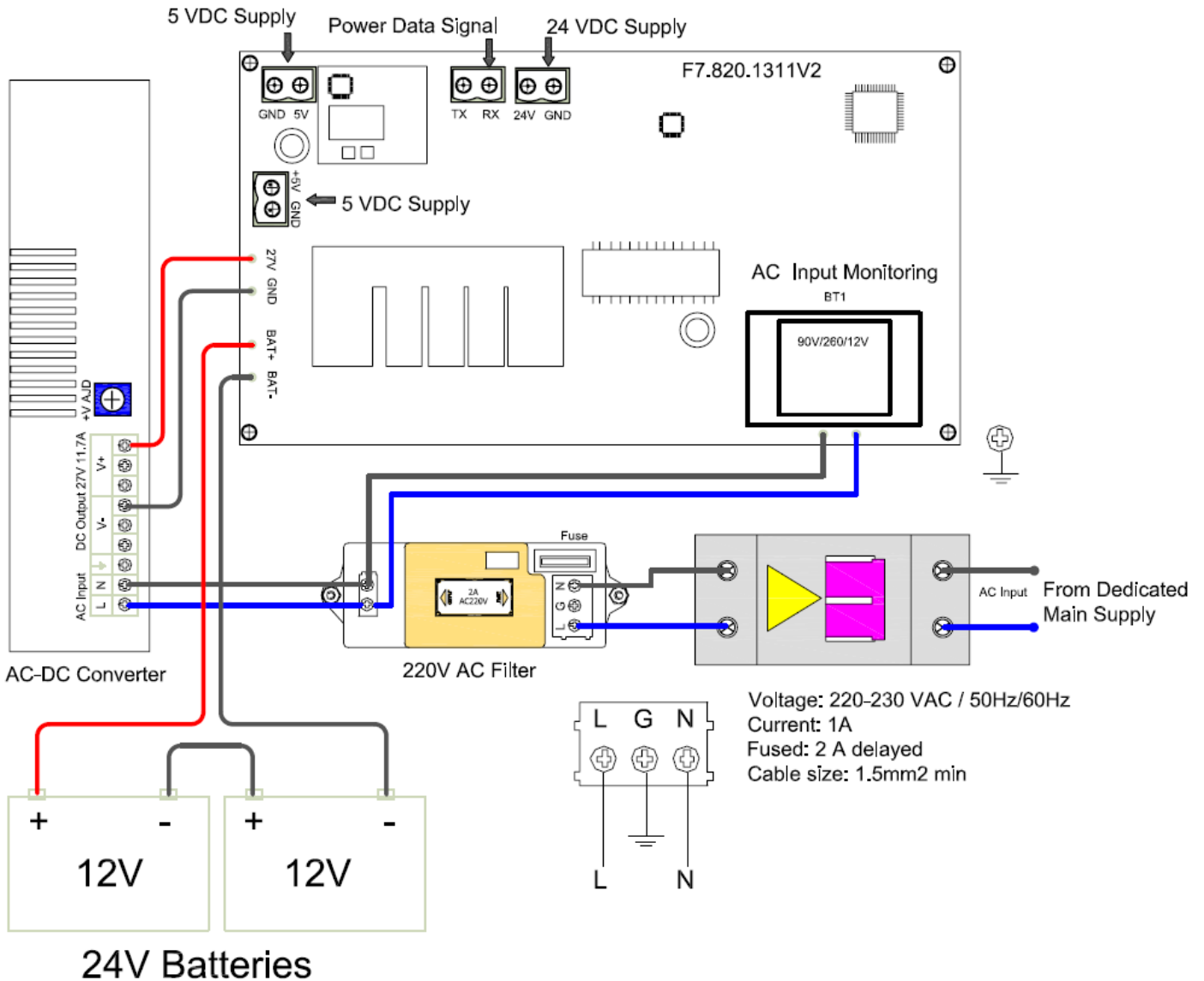

Standby Batteries

Maximum Charge Current: 2A±0.1A

Maximum Charge Voltage: 27.3V±0.3V

Type: Sealed lead acid batteries

Maximum Charge Capacity: Two 12V/38Ah batteries

Recommended manufacturer and model of battery: Yuasa NP38-12I

Maximum Internal Resistance: 0.7Ω

Quiescent Current under Full-loaded Condition: 1.4A

Maximum Operating Current: 4.2A

Recommended Cable: GST fire cable

Main Control Board

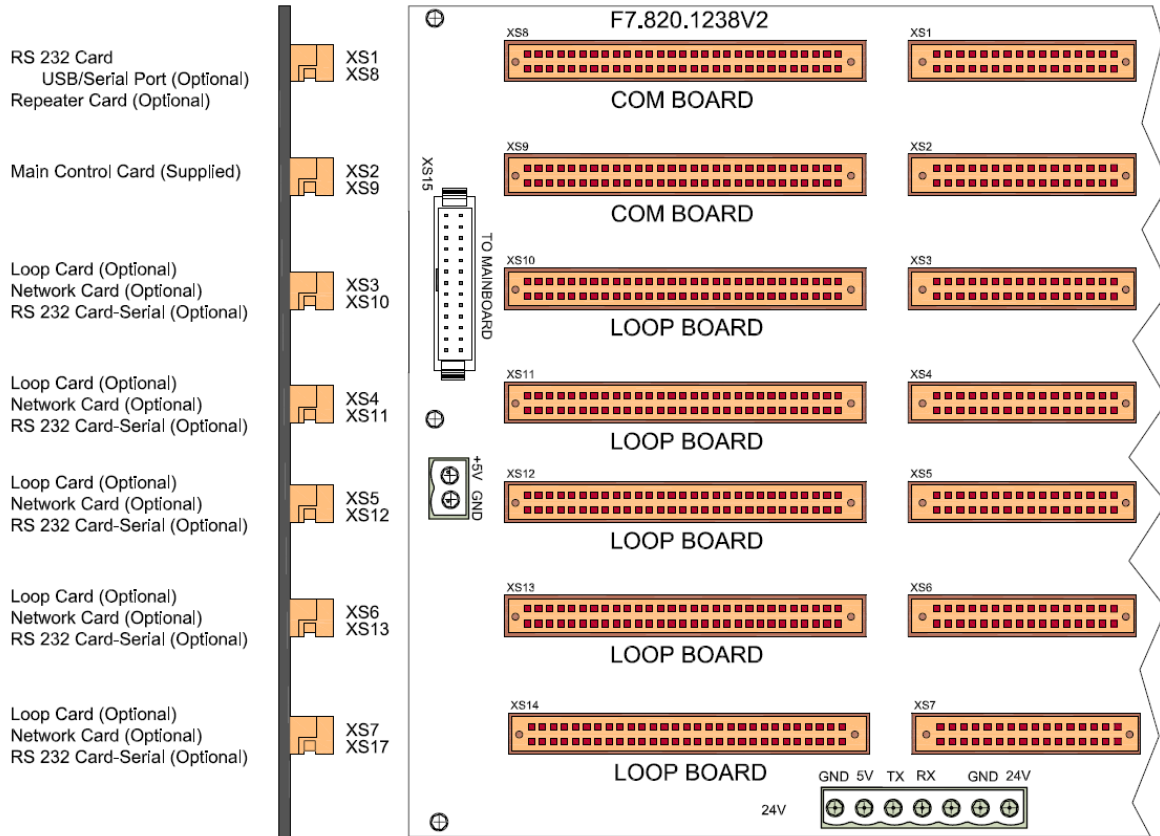

Warning:

Use static precautions when handling boards, grounding wrist strap and contact with chassis.

Setting the card address

Numbering sequence, lower card is the recommended lowest numerical setting. Set dials on the additional board in ascending order. Each card must be set at least one higher digit than the lower card.

```

CARD SUM: 03 LOOP SUM: 04 SUM:0000
*****
LOOP 1: Loop Card, Devices Sum: 000
LOOP 2: Loop Card, Devices Sum: 000
LOOP 3: Loop Card, Devices Sum: 000
LOOP 4: Loop Card, Devices Sum: 000
LOOP 5: Net Card-01, Net Sum: 01
LOOP 6: CRT CARD -01

Press F1 to print LOOP DEVICES info
    
```

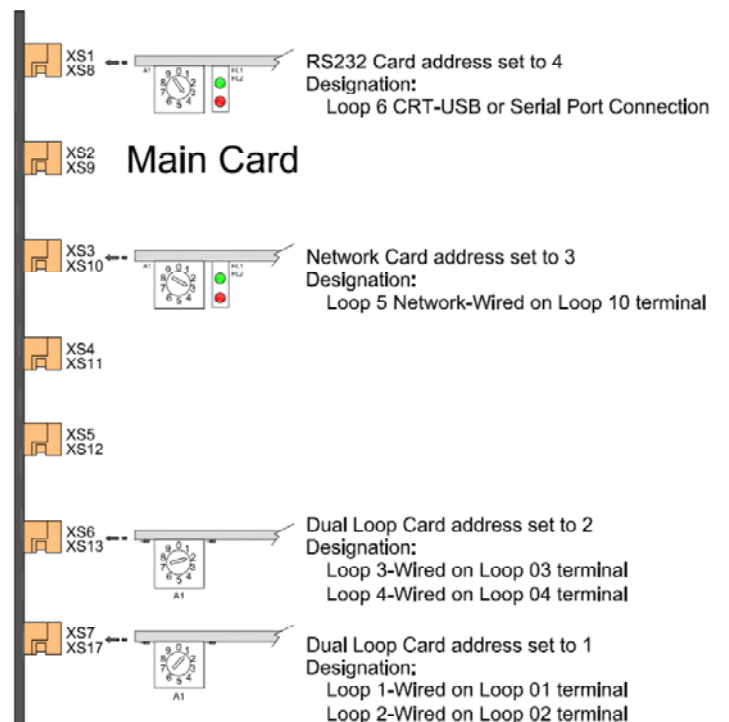

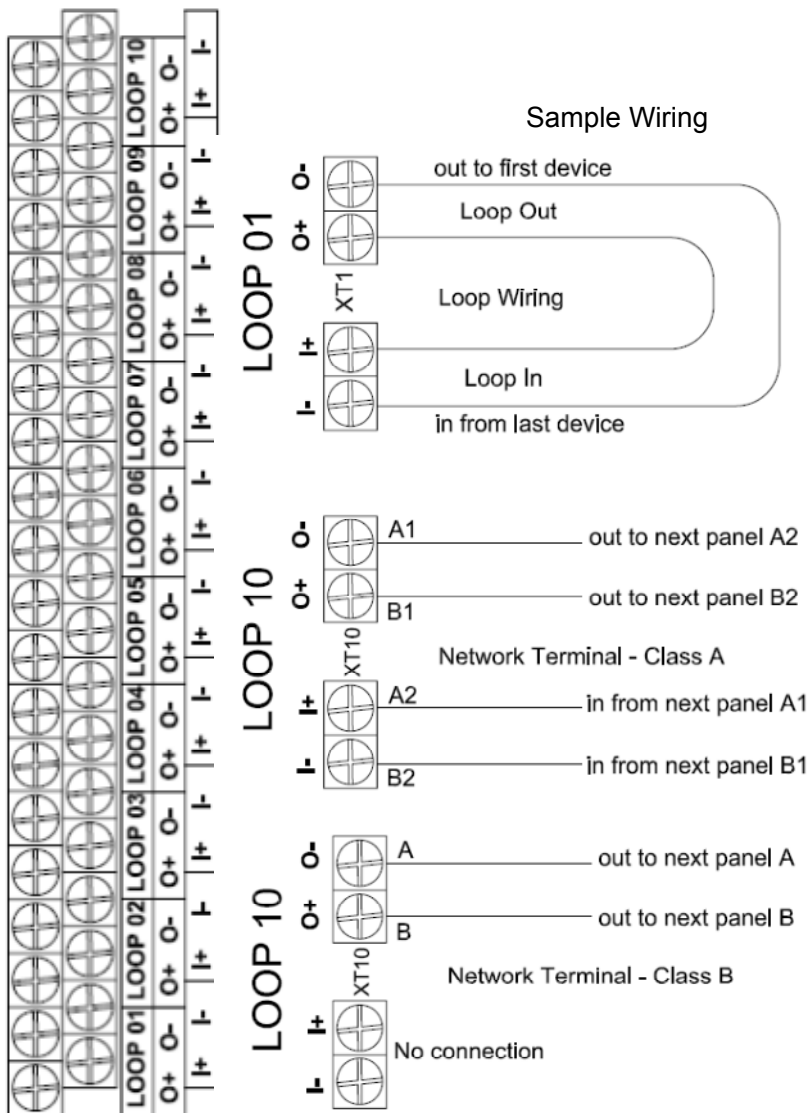

Loop Parameter LOOP1 ~ LOOP10

- 10 Loops+ Repeater Card
- 10 Loops + RS232 Card
- 8 Loops + RS232 Card + Network Card
- 8 Loops + Network Card + Repeater Card
- 6 Loops + RS 232 card + Network Card + Repeater Card

Loop Address: 242

Output Voltage: 21-27Vdc

Output Current: 300mA

Wiring Topology: Class A/Loop

Recommended Cable length: 1000 meters

Recommended Cable: GST Fire Cable

Loop protection: Optional loop isolator (C-9503/4)

Device Addressing

The device address can be programmed manually through handheld programmer (P-9910B) or can be changed in the control panel. The address of the device is recommended to be consecutive number but not limited in order to have flexibility and should not be repeated. The address is stored in the non-volatile memory chip inside the device

XT18					FAULT OUTPUT	NO COM NC	General Fault Output Signal Capacity: 24Vdc / 1A
XT14					REPEATER	A B	Repeater or Mimic panel terminal RS 485 Signal
XT19					FEED BACK	F1 F2	Feed Back- Input Signal Normally Open Contact / 4.7Kohms EOL 470 ohms must be fitted
XT13					ALARM ROUTING	- +	Output to FPE (FPE) Output:21-27Vdc /200mA /4.7Komhs EOL Device number: 000 000 83
XT12					OUTPUT TO SOUNDER	- +	Output to Sounder (OTS) Output:21-27Vdc /1A /4.7Komhs EOL Device number: 000 000 82
XT11					OUTPUT TO FPE	- +	Output to FPE (FPE) Output:21-27Vdc /200mA /4.7Komhs EOL Device number: 000 000 81

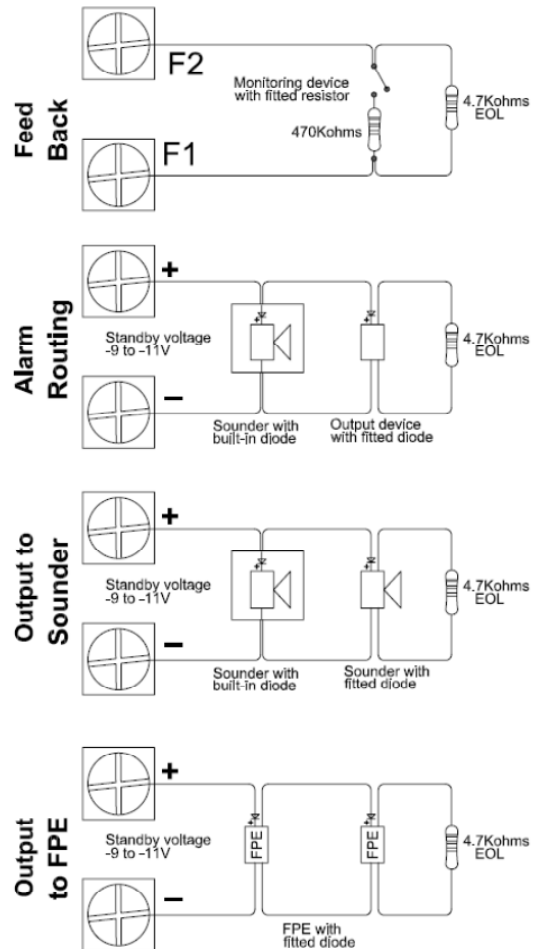

Description:

Output	Condition	Device Number	Alarm (Default)	Disable	CE Mode	Delay Time	Stop – via Silence Button
Alarm Routing	Routing A	00000083	Immediate	Yes	No	Yes	No
Output to Sounder	Sounder A	00000082	Immediate	Yes	Yes	Yes	Yes
Output to FPE	FPE A	00000081	Immediate	Yes	Yes	No	No

FEED BACK: Feedback signal input for alarm routing devices. It gives fault signal when connecting line is shorted or opened.

REPEATER: Connecting with repeater panel.

FAULT OUTPUT: Fault relay is closed in normal condition, and it's disconnected in fault condition.

Control Panel and Indication



Description of LEDs

Indicators	Colour	Description	How to clear
Display:		This provides the message of the events and system status.	
Fire	RED	When illuminated it indicate that a FIRE has been detected in the protected location	Attend the condition and perform the panel reset
Fault	YELLOW	When illuminated it indicate that a FAULT has been detected in the devices and alarm system.	Correct the condition that cause fault and automatically clear the indication or perform a panel reset
Pre-Alarm	YELLOW	When illuminated it indicate that a PRE-ALARM has been detected in the specified zone(s)	Attend the condition and press the ACK button to turn the system to Pre-alarm verification.
Verify	YELLOW	When illuminated it indicates that the ACK button has been pressed and the alarm sounders in the system are delayed from alarming.	Attend the condition and press EVAC button or nearest call point to alarm the sounder or perform the panel reset.
Maintenance	YELLOW	When illuminated it indicates that the panel is in programming mode.	Exit the programming menu, and automatically clear the indication
Battery Fault	YELLOW	Yellow. When illuminated it indicates that the battery has been failed.	Replace the battery or check the connections.
System Fault	YELLOW	When illuminated it indicates that the fault has occurred with the main processor. It is suggested to investigate the fault due to the panel will not able to attend the fires.	Turn –off and on the panel
Ground Fault	YELLOW	When illuminated it indicates that the panel or loop wiring is grounded	Clear the ground fault
Sounder Fault	YELLOW	When illuminated it indicates that a fault in the loop sounders and panel sounder output.	Cancel after corrected the condition that cause sounder fault.
Test Mode	YELLOW	When illuminated it indicates one or more zones are in test mode.	Cancel test when finished
Sounder Disable	YELLOW	When illuminated it indicates that part or all of the sounder has been disabled manually.	Enable the device/s and automatically clear the indication
Disable	YELLOW	When illuminated it indicates that part of the panel has been disabled	Enable the device/s and automatically clear the indication
Delay Mode	YELLOW	When illuminated it indicates that part of the system output is block by delayed.	Disable the delay mode

Power	GREEN	When illuminated it indicates the power supply is present	N/A
SILENCE	YELLOW	When illuminated it indicates that the SILENCE button has been pressed and.	Correct the alarm condition then perform the panel rest. Note: If there a new alarm occurs, the panel will resound again.
EVAC	RED	When illuminated it indicates that the EVAC button has been pressed	

Description of Controls



SYSTEM SETUP: The System Set-up button is used to access to the system menu. Each option in the menu corresponds to one number button. This is accessible under the manager password.

USER SETUP: The User Set-up button is used to access to the user menu. Each option in the menu corresponds to one number button. This is accessible under the operator password.

Numerical and Alphabetic Keys (1, 2ABC, 3DEF, 4GHI, 5JKL, 6MNO, 7PQRS, 8TUV, 9WXYZ, 0, \square , *): This button is used to enter the data manually at the control panel.

RESET: Pressing the Reset button will clear all the events and return the panel into a normal state.

MUTE: Pressing the Mute button will stop the internal panel buzzer

SILENCE: Pressing the Silence button will stop panel sounder output and loop sounders which programmed as device type 12, 13, 14, 28, 29, and 30

EVAC: Pressing the EVAC button will start panel sounder output and loop sounders which programmed as device type 12, 13, 14, 28, 29, and 30

ACK: Pressing the ACK button will stop internal panel buzzer and or acknowledging fire alarm under pre-alarm condition.

CANCEL: Pressing the CANCEL button will cancel the operation and shifted the display the message display to the highest priority.

ENTER: Pressing the Enter button will confirm entry.

▽, △▷ ◀ : For turning pages or changing the input position.

Zone Indication Panel

Every FACP comes with two zone indication panels, appearance of which is shown in Fig. 3-4.

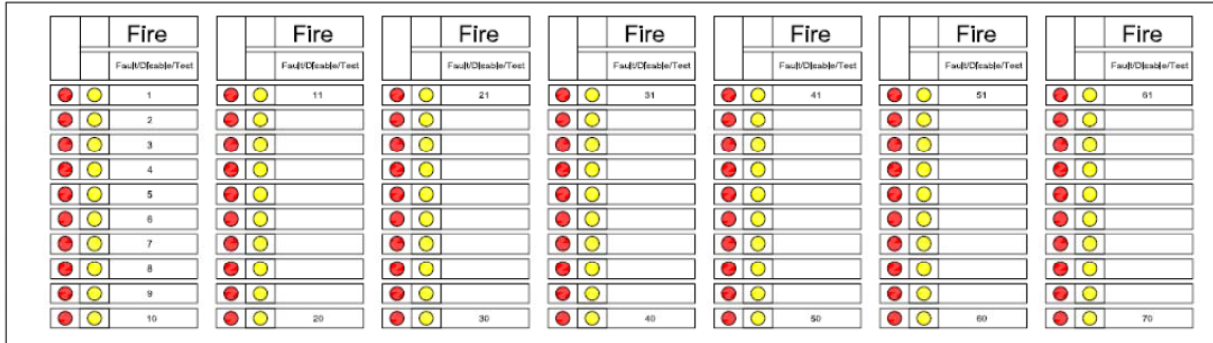

ZS2
 Factory Setting:
 The ZS2 jumper is not-shortcd means board number 1 and the LED is set to number 1 to 70



ZS2
 Factory Setting:
 The ZS2 jumper is shortcd means board number 2 and the LED is set to number 71 to 140

On the indication panel, each unit consists of two indicators and a label. The user can put the name of device on the right of the indicators.

Indicators	Colour	Description	How to clear
Zone Fire	Red	When illuminated it indicates that the zone is in a fire condition	Attend the alarm condition and then reset the panel
Zone Fault	Yellow	When illuminated it indicates that the zone is in a fault condition	Correct the fault condition and then reset the panel

System Commissioning

Commission Mode

The control panel should be set to commissioning mode in order to have a full access in any programming menu of the system.

To set the control panel in or out of commissioning mode:

- Press the **SYSTEM SETUP** button, input the management password, no default password just press **Enter**
- Then press number 3 button or using the cursor up and down and select **3 WORKING STATE SETUP** the press **Enter**

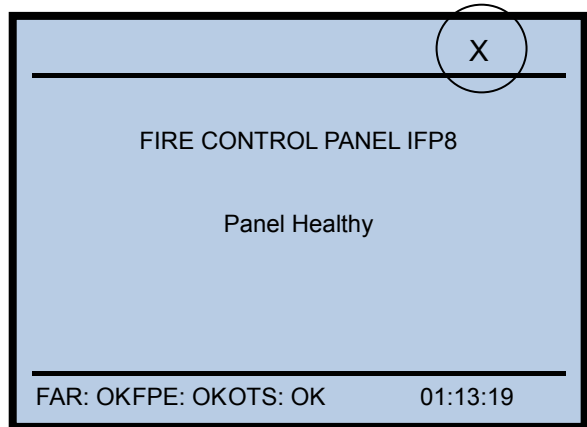
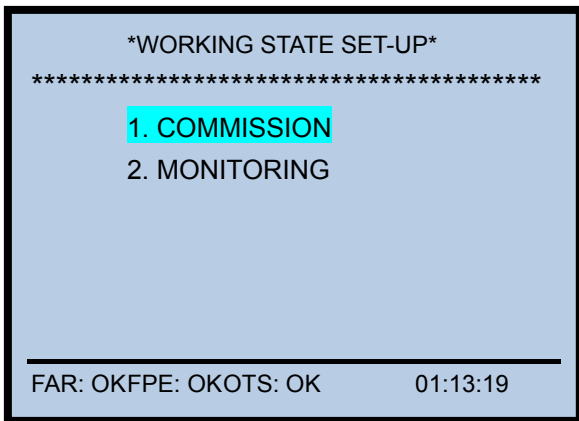

If there is an “X” displayed in the upper right corner of the screen, it is indicated that the panel is in commissioning mode.

Note: After the completion of commissioning, the control panel should be to set to “MONITORING MODE” and the “X” indicator will disappear.

How to register a devices/Auto Learn

The devices should be wired correctly and cards inserted properly and both are appropriately set the address without any duplication. Starts the auto learn.

To set the control panel in registration mode:

- Press the **SYSTEM SETUP** button, input the management password, no default password just press **Enter**
- Then press number 4 button or using the cursor up and down and select **4 Commissioning** then press **Enter**
- And then press number 1 or using the cursor up and down and select **1 Device Learn** and press **Enter**

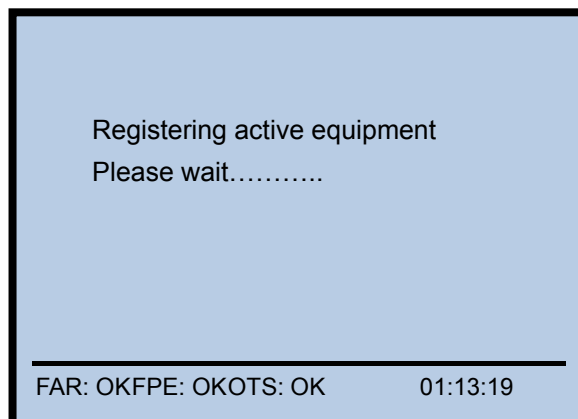

How to check duplicated address and device mismatch

To access the duplicated address check and device mismatched the system should be in DIGITAL mode (see the System Initialization). The device mismatch will indicate if given a wrong device type on the actual installed detector. This function is only allowed in smoke, heat and multi-sensor detector.

- Press the **SYSTEM SETUP** button, input the management password, no default password just press **Enter**
- Then press number 4 button or using the cursor up and down and select **4 Commissioning** then press **Enter**
- And then press number 2 button or using the cursor up and down and select **2 Duplicated Address Check** the press **Enter**.

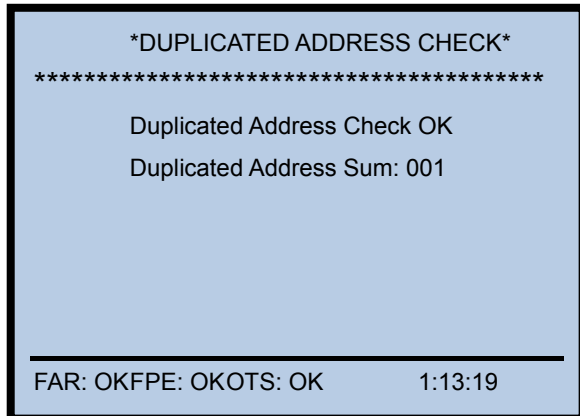
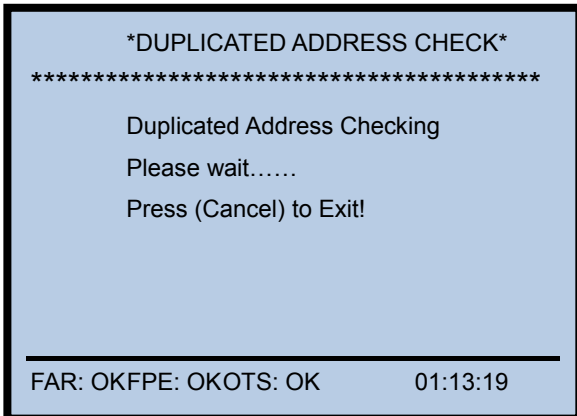

If the system found the devices with duplicated address, the total number will be displayed. To find the exact addresses and loop location press **USER SETUP** button and select **1 BROWSE** then select **4 BROWSE DUPLICATED ADDRESS**

How to modify the device address

To access modify address the system should be in DIGITAL mode (see the System Initialization)

- Press the **SYSTEM SETUP** button, input the management password, no default password just press **Enter**
- Then press number 4 button or using the cursor up and down and select **4 Commissioning**
- And then press number 2 button or using the cursor up and down and select **3 MODIFY ADDRESS** then press **Enter**
- Input the loop and the device address to be changed the press **ENTER**
- Then input the new preferred address then press **ENTER**.

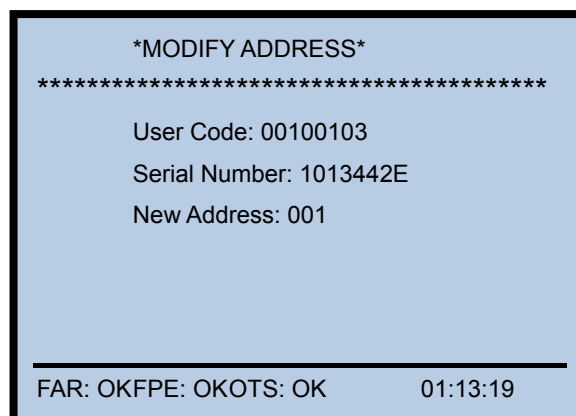

How to modify the device sensitivity

To access modify sensitivity the system should be in DIGITAL mode (see the System Initialization)

- Press the **SYSTEM SETUP** button, input the management password, no default password just press **Enter**
- Then press number 4 button or using the cursor up and down and select **4 Commissioning**
- And then press number 2 button or using the cursor up and down and select **4 MODIFY DEVICE SENSITIVITY**
- Input the loop and the device address to be changed the press **ENTER**.

Note: Be sure that the selected detector is programmed

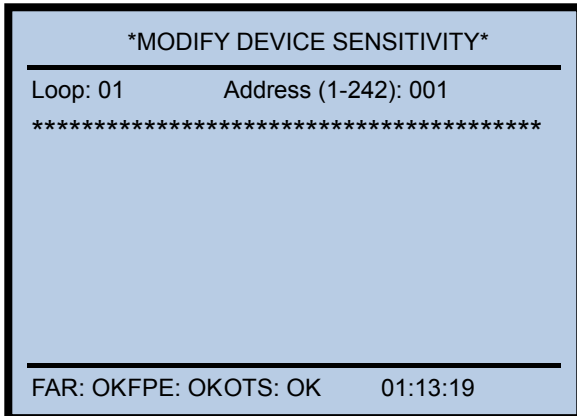

The system verified the existing device sensitivity **ENTER**.

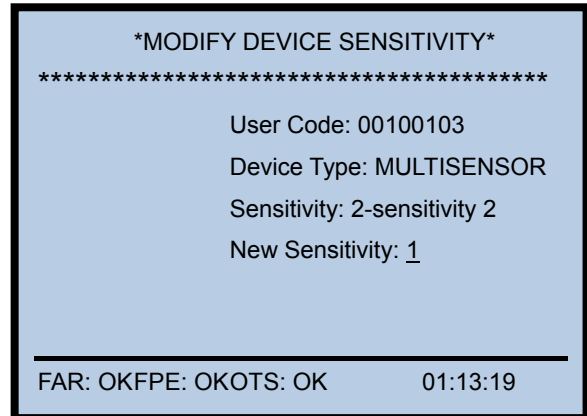

Then input the new sensitivity of the detector then press

System Programming

The control panel should be set to commissioning mode in order to have a full access in any programming menu of the system.

How to program the device detail

To set the control panel in programming the device detail:

- Press the **SYSTEM SETUP** button, input the management password, no default password just press **Enter**
- Then press number 1 button or using the cursor up and down and select **1 PROGRAMMING**
- And then press number 1 button or using the cursor up and down and select **1 DEVICE SETUP**

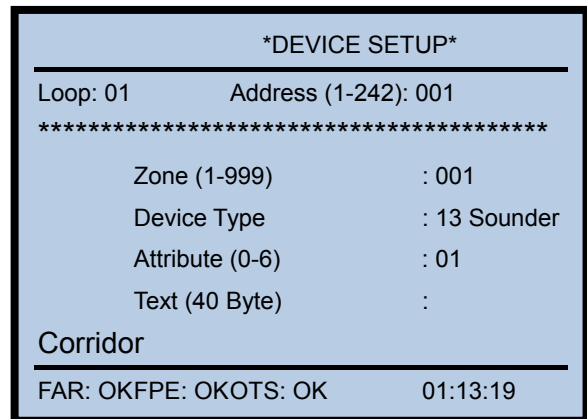
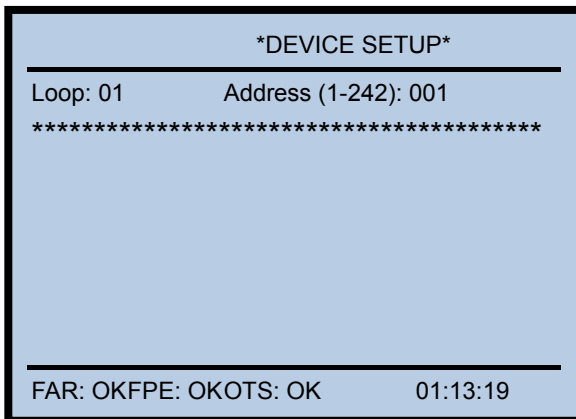

- Input the loop and the device address to be changed the press **ENTER**

Device Parameters

Zone: Zone assignment

Device Type: Selection of device type.

Attribute: For output- 0-on/off ; 1-continous

For detector- Sensitivity 1,2 or 3

Text: Device location text, character 40 max

How to encode the text

All the required letters and symbols are programmed in the system. The number keys have letter is corresponding with the number button; each number has designated a capital or small letter.

Sample text encoding

Corridor

- C - Press number **2** button then press 7 for capital C
- o - Press number 6 button then press 4 for small letter o
- r - Press number 7 button then press 4
- r - Press number 7 button then press 4
- i - Press number 4 button then press 4
- d - Press number 3 button then press 2
- o - Press number 6 button then press 4
- r - Press number 7 button then press 4 for small letter r

How to program the zone

To set the control panel in programming the zone

- Press the **SYSTEM SETUP** button, input the management password, no default password just press **Enter**
- Then press number 1 button or using the cursor up and down and select **1 PROGRAMMING**
- And then press number 1 button or using the cursor up and down and select **2 ZONE SETUP**

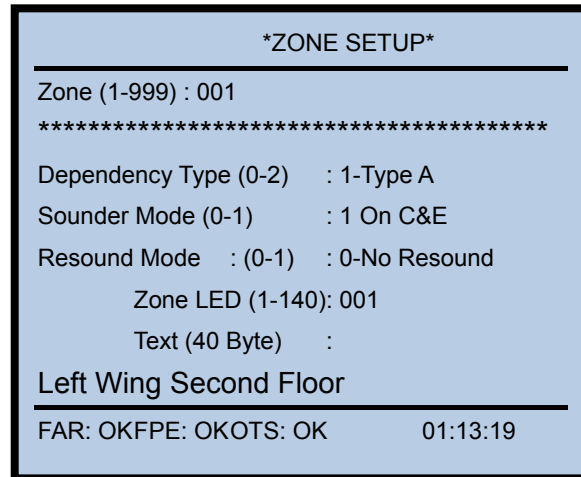
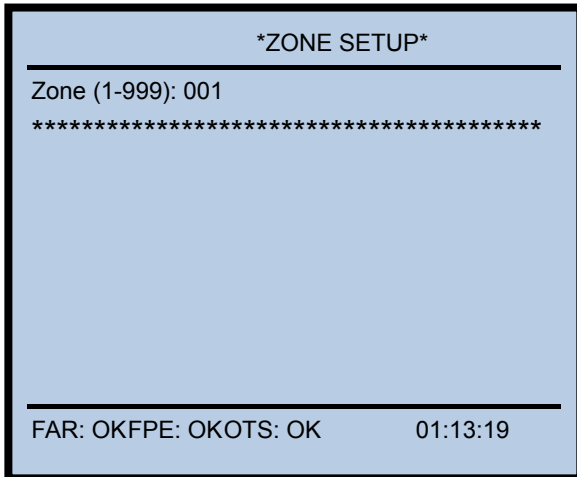

- Input the 3 digits zone number then press **ENTER**

Zone Parameters

Dependency Type (0-2)

0-Off: Panel display Fire immediately- No Pre-alarm feature

1-Type A: Enable Pre-alarm feature- the system shall response to a second alarm from any device in the same zone as the system alarm (Type A)

2-Type B: Enable Pre-alarm feature- the system shall response to a second alarm from any device in the same or other zone as the system alarm (Type B)

Sounder Mode

0-Sound by Zone Fire: Alarm the sounder automatically if the fire is on the same zone

Ex: fire in zone 1, all the sounders in zone 1 will alarm

1-On E&C: Activation of Sounder through Equation

Resound Mode

0-No Resound: Sounder will not alarm if new fire from the other zone after being silenced

1-Resound by New Fire: Sounder will alarm if new fire from other zone after being silenced

Zone LED: 1-140 LED

Text: Zone location text, character 40 max

To encode the text use the alphanumerical buttons

How to program the equation

To set the control panel in programming the equation

- Press the **SYSTEM SETUP** button, input the management password, no default password just press **Enter**
- Then press the number 1 button or using the cursor up and down and select **6 C&E EQUATION SETUP** then press **Enter**.

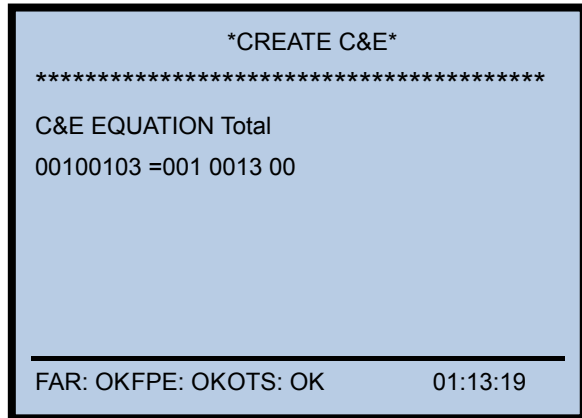
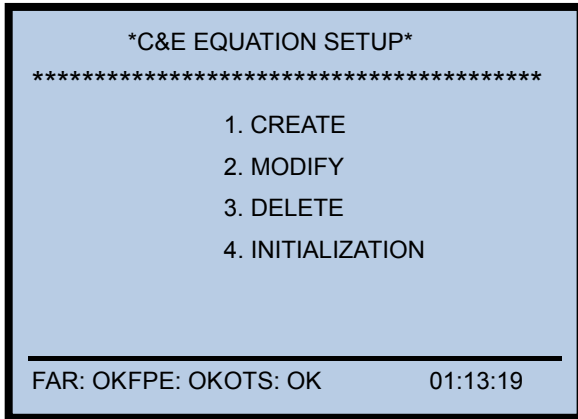

C&E Equation Parameters

Condition: INPUT DEVICES- 8 digits

Effect: OUTPUT DEVICES – 10 digits

Logic: AND Logic (x), OR Logic (+)

Fuzzy Logic: Asterisk (* value from 1-9)

Start the output: =

Stop the output: =X

$\underbrace{999}_{\text{Zone}} \underbrace{242}_{\text{Address}} \underbrace{99}_{\text{Device Type}} = \underbrace{999}_{\text{Zone}} \underbrace{242}_{\text{Address}} \underbrace{99}_{\text{Device Type}} \underbrace{99}_{\text{Delay Time}}$

Condition

001 020 03 meaning Address 20 Optical smoke in Zone 1 (By Point)

001 *** 03 meaning At least 1(*any address*) Optical smoke in Zone 1 (By Zone)

*** *** 02 meaning At least 1(*any address*) Heat det. in the entire area (Global)

Effect:

XXX XXX 13 03 means sounder global alarm after 30 seconds (Global)

Sample:

001 *** 11 + 001 *** 03 + 001 *** 02 = 001*** 13 00, *** *** 13 06

How to edit the device type

To set the control panel in programming the device type

- Press the **SYSTEM SETUP** button, input the management password, no default password just press **Enter**
- Then press the number 1 button or using the cursor up and down and select **7 Device Type Setup** then press **Enter**.

No.	Device Type	No.	Device Type	No.	Device Type	No.	Device Type
00	UNDEFINED	25	USER DEFINED	50	USER DEFINED	75	Undefine
01	MULTISENSOR	26	USER DEFINED	51	USER DEFINED	76	Loop Short
02	HEAT DETECTOR	27	USER DEFINED	52	USER DEFINED	77	Loop Board
03	OPTICAL SMOKE	28	USER DEFINED	53	USER DEFINED	78	Delay Mode
04	USER DEFINED	29	USER DEFINED	54	USER DEFINED	79	Power Board
05	GAS DETECTOR	30	USER DEFINED	55	NET SounderA	80	CRT Board
06	BEAM DETECTOR	31	TROUBLE MONITOR	56	USER DEFINED	81	F.P.E.A
07	FLAME DETECTOR	32	PSU	57	USER DEFINED	82	SounderA
08	CONVENTIONAL P	33	USER DEFINED	58	USER DEFINED	83	ALARM ROUTINGA
09	USER DEFINED	34	USER DEFINED	59	USER DEFINED	84	Loop Flash Data
10	FLOW SWITCH	35	USER DEFINED	60	USER DEFINED	85	Undefine
11	MCP (BG)	36	USER DEFINED	61	USER DEFINED	86	Panel charger
12	SOUNDER STOBE	37	USER DEFINED	62	USER DEFINED	87	BAT Resistance
13	SOUNDER	38	USER DEFINED	63	USER DEFINED	88	Undefine
14	FLASHER	39	Net Unit	64	USER DEFINED	89	Undefine
15	LIFT	40	Repeater	65	NET F.P.E.A	90	Undefine
16	FIRE DAMPER	41	ZONE VALVE	66	Undefine	91	Undefine
17	FIRE DOOR	42	FLOW SWITCH	67	Loop SW	92	Undefine
18	AHU	43	PRESSURE SWITCH	68	Loop Board	93	Undefine
19	EXTRACT FAN	44	USER DEFINED	69	CONTROL Panel	94	Undefine
20	BMS	45	USER DEFINED	70	ZoneDir Board	95	Undefine
21	USER DEFINED	46	USER DEFINED	71	AC Power	96	Undefine
22	USER DEFINED	47	USER DEFINED	72	Battery	97	Undefine
23	USER DEFINED	48	USER DEFINED	73	Keypad Board	98	Undefine
24	USER DEFINED	49	USER DEFINED	74	Ground.F	99	Undefine

- The device type text description can be modified as user requirement through pressing **F2** function key
- Encode the text using alphanumeric keypad and confirmed by pressing **Enter**

System Browsing

To view the control panel programmed

- Press the **USER SETUP** button, input the user password, no default password just press **Enter**
- Then press number 1 button or using the cursor up and down and select **1 BROWSE** the press **Enter**

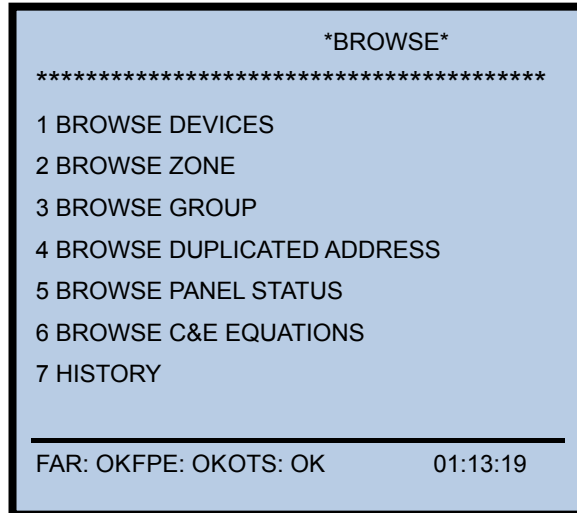

To view the device detailed

- Press the number 1 button or using cursor up and down and select **1 BROWSE DEVICE**
- Select the loop using arrow cursor up or down and press **Enter**. To print selected the loop information press **F1** function key

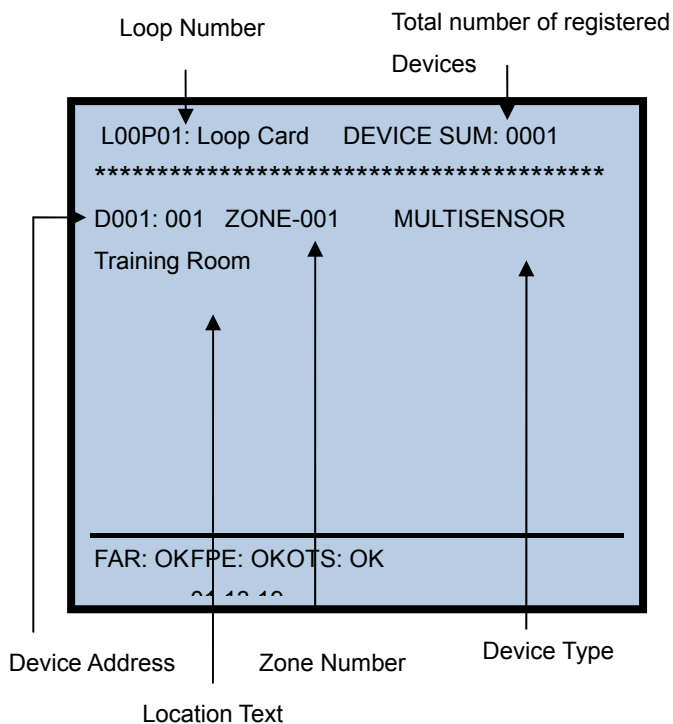

To view the zone (INPUT) assignment

- Press the number 2 button or using cursor up and down and select **2 BROWSE ZONE**
- Select the loop using arrow cursor up or down and press **Enter**.

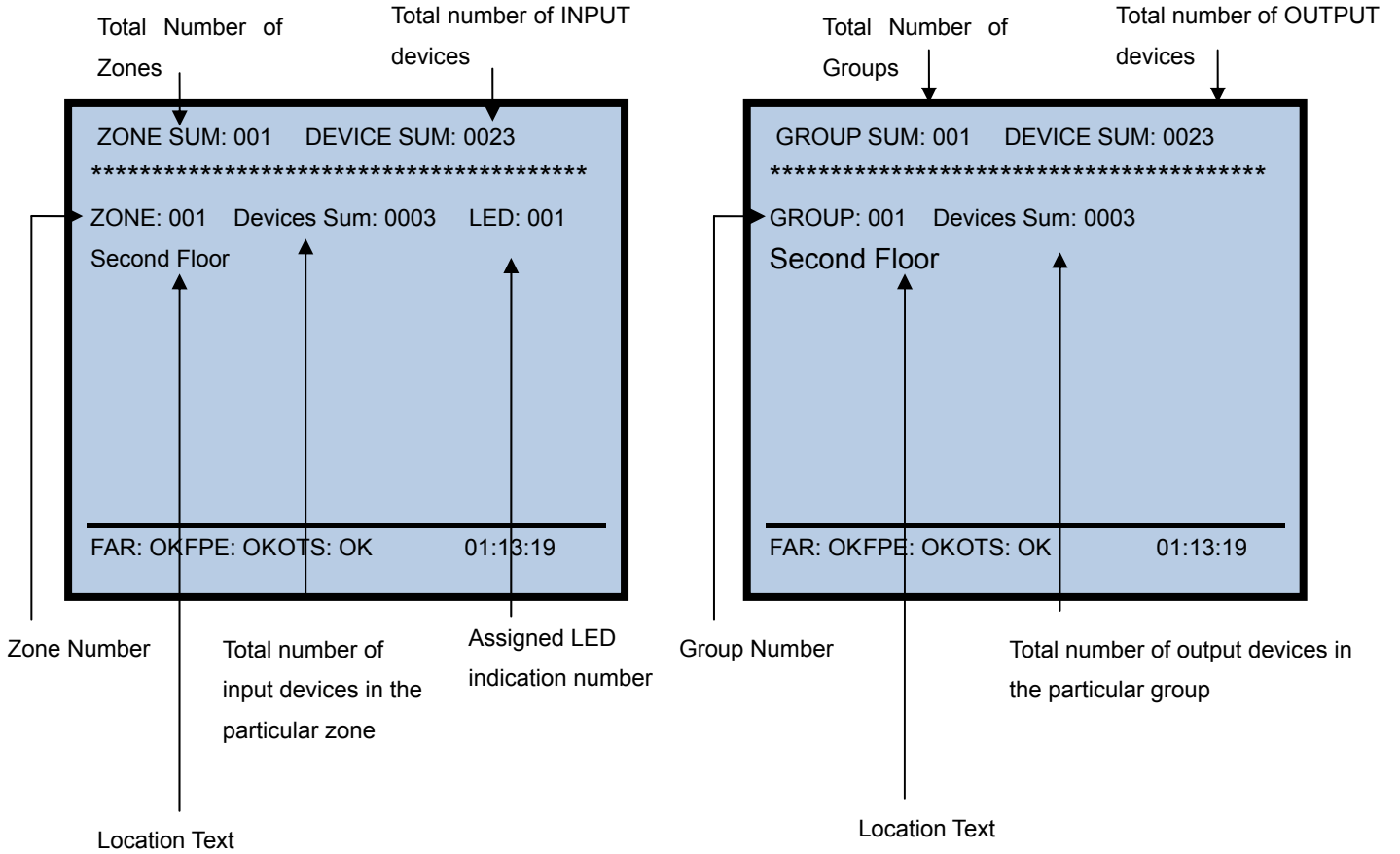

To view the list of devices that are belong to a particular zone, select the zone using the arrow cursor **UP or Down** and then press **Enter**.

To view the group (OUTPUT) assignment

- Press the number 1 button or using cursor up and down and select **1 BROWSE GROUP**
- Select the loop using arrow cursor up or down and press **Enter**.

To view the list of devices that are belong to a particular zone, select the zone using the arrow cursor **UP or Down** and then press **Enter**.

Note: 3 control panel outputs (FAR, FPE, OTS) included in the group:

Group 000 Devices sum: 0003
Control Panelseft Info

To view the duplicated address

The duplicated address check under commissioning menu must be enabled first before viewing the address and the location of the loop.

To view the duplicated address on the control panel.

- Press the number 2 button or using cursor up and down and select **4 Browse Duplicated Address**
- Select the loop with duplicated address using arrow cursor up or down and press **Enter**.

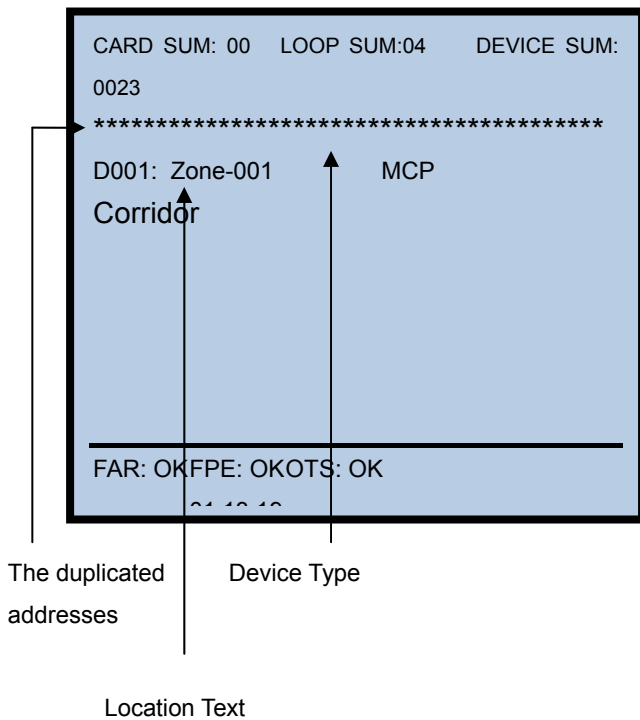

To view the panel status

When selected it view the number of card configured, total number of registered devices and control panel power and system version.

- Press the number 5 button or using cursor up and down and select **5 Panel Status**

To view the C&E Equation

When selected it view the configured cause and effect in the control panel. To edit the equation refers to C&E programming set-up.

- Press the number 6 button or using cursor up and down and select **6 Browse Event and Command**.
- Select the equation using arrow cursor **UP and Down** then press **Enter**
- **Initialization** is for deleting all the equations, required master password.

To view the system history

The history memory is divided in two parts FIRE HISTORY which stored only fire event and COMMON HISTORY for different types of system event except fire. Both have the 999 event capacity in non-volatile memory

To view the events in the control panel:

- Press the number 7 button or using cursor up and down and select **HISTORY** then **Enter**
- Select the event using arrow cursor **UP and Down** then press **Enter**
- To print the selected event press **Enter**

Note: Ensure that the printer is placed to **ALL HISTORY**.

SET-UP OPTION

To set-up the clock

This set-up allows the current date and time to be specified and entered into the panel memory.

- Press the **USER SETUP** button, input the user password, no default password just press **Enter**
- Then press number 2 button or using the arrow cursor up and down and select **2 CLOCK** then press **Enter**

To set-up the printer

This set-up allows to printer on or off condition

- Press the **USER SETUP** button, input the user password, no default password just press **Enter**
- Then press number 3 button or using the arrow cursor up and down and select **3 PRINTER SETUP** then press **Enter**
 1. **Disable** – Printer in off condition
 2. **Only Fire** – Automatic print in the event of fire
 3. **All History** – Enable the printer.

To set-up the delay mode

This set-up allows the panel to delay the any output device type in the C&E Equation according to the specified time.

NOTE: *The panel operates in a delayed mode during the daytime only.*

- Press the **USER SETUP** button, input the user password, no default password just press **Enter**
- Then press number 4 button or using the arrow cursor up and down and select **4 DELAY MODE SET-UP** then press **Enter**.
- Select **ENABLE** or **DISABLE** then press **Enter**

To set-up the local outputs

This set-up allows the 3 on-board output circuits to delayed and placed in one or more alarm.

- Press the **SYSTEM SETUP** button, input the system password, no default password just press **Enter**
- Then press number 2 button or using the arrow cursor up and down and select **2 Local Output Setup** then press **Enter**.
- Select the output circuits to set-up

Selection:

0 One Fire – Immediate start in any fire event

1 More Fire – Started if two or more fire events

2 On C&E – Start based on the configured equation.

Delay time - Works only in Output to Sounders (OTS) and Alarm Routing (FAR) and the ratio **1:10 seconds**.

Note: *Allows only if the DELAY MODE is set to enable*

Output	Condition	Device Number
Fire Alarm Routing	Routing A	00000083
Output to Sounder	Sounder A	00000082
Output to FPE	FPE A	00000081

SYSTEM OPERATION

Dependency Mode/ Pre-alarm

The signal from an automatic fire detection device selected for positive alarm sequence operation shall be acknowledged at the fire alarm control unit by a trained personnel within given time of annunciation in order to initiate the alarm investigation phase. If the signal is not acknowledged within the given time, notification signals in accordance with the building evacuation or relocation plan and remote signals shall be automatically immediately activated.

To program the pre-alarm of the panel in specified zones:

1. Ensure a zone(s) are programmed either Type A or Type B dependency to enable the mode (Check in zone configuration)
2. Ensure that the **DELAY MODE** is placed on **ENABLE**
3. Set the **Day/Night Mode**:

To set-up the panel into Day mode:

- Press the **SYSTEM SETUP** button, input the management password, no default password just press **Enter**
- Then press the number 4 button or using the cursor up and down and select **4 DAY/NIGHT SETUP** then press **Enter**.

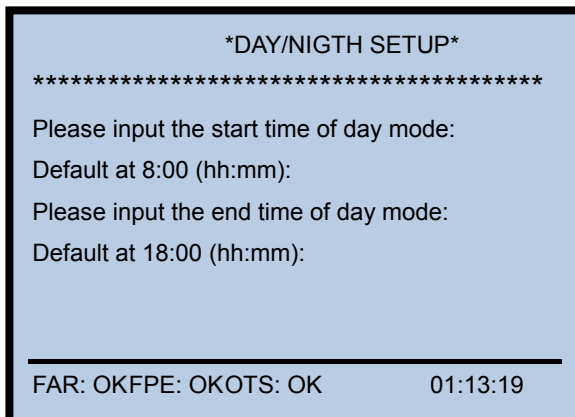

- Enter the time using the number buttons

4. Program the two stage timer which is built into a day mode.

To program the two stage timer:

- Press the **USER SETUP** button, input the user password, no default password just press **Enter**
- Then press number 5 button or using the arrow cursor up and down and select **4 ACKNOWLEDGE TIMER** then press **Enter**.

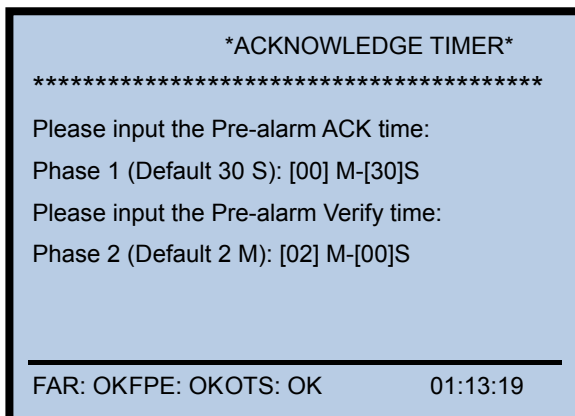

- Enter the time using the number buttons and press Enter

***Day Mode**

Pre-alarm Window: programmable from 1 sec. to 30 min. A distinctive pre-alarm indication shall be displayed.
Alarm Verification window: programmable from 1 sec. to 30 min.

***Night Mode (Default setting)**

Pre-alarm Window: preprogrammed 30 min. Auto-reset the Alarm in the Panel after 30 min (Type A)
Pre-alarm Window: preprogrammed 5 min. Auto-reset the Alarm in the Panel after 5 min (Type B)

The system shall response to a second alarm from any device in the same zone as the system alarm (Type A)
The system shall response to a second alarm from any device in the same or different zone as the system alarm (Type B)

The manual call points are excluded in the pre-alarm mode.

Test Mode

The control panel is in test status and indicates the zone under test condition.

To set the panel into test mode

- Press the **USER SETUP** button, input the user password, no default password just press **Enter**
- Then press number 6 button or using the arrow cursor up and down and select **4 TEST SETUP** then press **Enter**.

Selection:

1 LED Buzzer test – When selected the panel ON all the LED and start the buzzer.

2 Local Output Test – Is for testing the 3 on-board output circuits. When selected, it will indicate **TEST** message and alarm the output within 15 seconds.

3 Set-up Test Zone – Possible one or more zones can be set to test condition with or without loop sounder assigned to a zone within 10 seconds.

4 Cancel Test Zone – canceled by manual operation.

START/STOP OPTION

Any or group of device registered onto the control panel can start by manual operation by entering the zone number, address and device type.

To set the panel into test mode

- Press the **USER SETUP** button, input the user password, no default password just press **Enter**
- Then press number 7 button or using the arrow cursor up and down and select **7 STOP/START DEVICE** then press **Enter**.

DISABLE/ENABLE OPTION

Any or group of device registered onto the control panel can disable by manual operation by entering the zone number, address and device type.

To set the panel into test mode

- Press the **USER SETUP** button, input the user password, no default password just press **Enter**
- Then press number 8 button or using the arrow cursor up and down and select **8 DISABLE/ENABLE** then press **Enter**.

Maintenance

The FACP shall only be repaired by specially trained GST technical service personnel. Please disconnect the power before repair!

Warning: The key to the FACP shall be kept by specially assigned maintenance personnel!

Replacing the Battery

Type of battery: Sealed lead-acid battery

Recommended period for replacing the battery: 5 years (25°C)

Recommended manufacturer and model: Yuasa/NP38-12I

Disposal of used batteries: Please properly dispose the used batteries according to your local rules and regulations.

NOTE: RISK OF EXPLOSION IF BATTERY IS REPLACED BY AN INCORRECT TYPE.

Replace of Fuse

Position	Mark	Rating
Power filter F7.820.323	F1	2A delay

Troubleshooter

No.	Problems	Possible Causes	Solutions
1	No indication on the panel or abnormal indication	Power is abnormal Loose connection with switchboard.	Check and replace low-voltage switch power. Check the connection to display board.
2	Display "AC Fault" after power-up.	No AC power	Check and connect AC wire.
3	Display "Battery Fault" after power-up.	Loose connection with battery. Battery discharged or damaged.	Open the power box and check relative parts. Power up for more than eight hours with the AC power supply, if the fault still exists, replace the batteries.
4	Unable to register loop equipment	Bus wrong or loose connection	Check the loop
5	Unable to register repeater panels	Wrong or loose connection of communication cables	Check power supply to repeaters and communication wires
6	Cannot print	Print mode is disabled. Loose connection with printer. Printer damaged	Enable the print mode. Check and connect the printer well. Replace the printer.
7	Equipment fault	Equipment disconnected. Equipment damaged.	Check connection Replace equipment
8	Loop fault	Loop is shorted	Check the loop and repair.
9	Clock or memory fault.	External interference. Corresponding parts are aging.	Check if the FACP is properly earthed. Inform our technical service

System Menu

System Setup

1 PROGRAMMING

1 Point-Setup: loop 01 point (1-242)

Zone (1-999):

Device Type:

Attribute (0-6):

Text (40 byte):

2 Zone Setup: (1-999) (*Select the zone*)

Dependency type (0-2)

0 – Off

1 – Type A

2 – Type B

Sounder Mode (0-1)

0 – Sound by Zone Fire

1 – On E&C

Resound Mode (0-1)

0– No Resound

1 – Resound by New Fire

Zone LED (1-140): Text (40byte)

3 Communication Setup

1. Monitor interface (interface card RS232)

Please input loop number: (1:10)

Please input panel address: (1-32)

2 Network Interface

Please Input loop number: (1-10)

Please Input panel address (1-64)

4 Day / Night time Set-up

Please Input start time of day mode (08:00) default

Please Input the end time of day mode (18:00)

5 Modify Password

1. Operator Password

2. Manage Password

6 C&E Equation Set-up

1. Create

2. Modify

3. Delete (one by one)

4. Initialization (To clear all the equation)

7 Device Type Set-Up (see table 1)

2. LOCAL OUTPUT SETUP

Sounder A Mode (0-2)

- 0-one fire
- 1-more fire
- 2-On C&E

FPE A Mode (0-2)

- 0-one fire
- 1-more fire
- 2-On C&E

Alarm Routing A mode (0-2)

- 0-one fire
- 1-more fire
- 2-On C&E

Delay Time: 00 (*note: ratio 1:10*)

3. WORKING STATE SET-UP

1. Commission (*note: "X" upper right corner*)
2. Monitoring

4. Commissioning

1. Device Learn (To registered devices)
2. Duplicated Address Check
3. Modify Address (*To change the device address*)
 - Select the loop and device address
 - User Code: 00100106 (zone,address,device type)
 - Serial Number: device serial number
 - New Address: Enter new address
4. Modify Device Sensitivity (*To change the device sensitivity*)
 - Select the loop and device address
 - User Code: 00100106 (zone,address,device type)
 - Serial Number: device serial number
 - Sensitivity: existing sensitivity
 - New Sensitivity: Enter new sensitivity (1-3)
5. Commission in Analog Mode (Command 0)
 - Normal Status: Range 450 to 650
 - Alarm Status: Range from 900 to 1200
 - Fault Status: Range from 1 to 120
6. Commission in Digital Mode
7. System Initialization.
 - Press 1 Initialize detector to digital mode
 - Press 2 Initialize detector to analog mode
 - Press 3 To initialize the system
 - Press 4 To disable battery resistance,
 - Press 5 To hide sounder alert item

User Setup

1 BROWSE

- 1 Browse Devices: *View the number of devices per loop and detailed provided with each device*
- 2 Browse Zone: *View the total number of Input devices per zone*
- 3 Browse Group: *View the total number of Output devices per group (Zone)*
- 4 Browse Duplicated Address : *View the repeated address in a loop*
- 5 Browse Panel Status: *View the panel configuration and version*
- 6 Browse Event and Command: *C&E or Sequence of operation detailed*
- 7 History:
 - 1 Fire History
 - 2 Common History
 - 3 Initialization

2 CLOCK

3 PRINTER SETUP

- 1 Disable
- 2 Only Fire : *Automatic print on fire event*
- 3 All History: *Pressing PRINT when viewing history records can print out the messages being viewed*

4 DELAY MODE SETUP

- 1 Disable
- 2 Enable

5 ACKNOWLEDGE TIMER

- Phase 1 (30 seconds default)
- Phase 2 (2 minutes default)

6 TEST SETUP

- 1 LED Buzzer Test
- 2 Local Output Test
 - 1 Output to Sounder Test (OTS)
 - 2 Output to F.P.E. (FPE)
 - 3 Alarm Routing Test (FAR)
- 3 Setup Test Zone
 - Input test zone : (1-999)
 - Input test mode : (0-1)
 - 0-Without sounder
 - 1-With sounder
- 4 Cancel Test Zone
 - 1 Cancel One Test Zone
 - 2 Cancel All Test Zone

7 START/STOP DEVICE

1 Start Device

2 Stop Device

By device code- Zone, address, device type

8 DISABLE/ENABLE

1 Dis/Enable Devices – By Code

1 Disable Device

2 Enable Device

2 Dis/Enable Device – By Address

1 Disable Device

2 Enable Device

2 Dis/Enable Zone

1 Disable Zone

2 Enable Zone

1 Disable/Enable Sounder

1 Disable Sounder

2 Enable Sounder

Lists of Device Type and Condition

DEVICE TYPE	DEVICE NUMBER	RELAY	CONDITON
Undefine	0		FIRE
MULTISENSOR	1		
HEAT DETECTOR	2		
OPTICAL SMOKE	3		
USER DEFINED	4		
GAS DETECTOR	5		
BEAM DETECTOR	6		
FLAME DETECTOR	7		
CONVENTIONAL P	8		
USER DEFINED	9		
FLOW SWITCH	10		
MCP (BG)	11		ACTION
SOUNDER STOBE	12	Latching	
SOUNDER	13	Latching	
FLASHER	14	Latching	
LIFT	15		
FIRE DAMPER	16		
FIRE DOOR	17		
AHU	18		
EXTRACT FAN	19		
BMS	20		
USER DEFINED	21		
USER DEFINED	22		
USER DEFINED	23		
USER DEFINED	24		
USER DEFINED	25		
USER DEFINED	26		
USER DEFINED	27		
USER DEFINED	28	Latching	
USER DEFINED	29	Latching	
USER DEFINED	30	Latching	
TROUBLE MONITOR	31		FAULT
PSU	32		
USER DEFINED	33		
USER DEFINED	34		
USER DEFINED	35		
USER DEFINED	36		
USER DEFINED	37		

USER DEFINED	38		
Net Unit	39		
Repeater	40		
ZONE VALVE	41		
FLOW SWITCH	42		
PRESSURE SWITCH	43		
USER DEFINED	44		
USER DEFINED	45		
USER DEFINED	46		
USER DEFINED	47		
USER DEFINED	48		
USER DEFINED	49		
USER DEFINED	50		
USER DEFINED	51		
USER DEFINED	52		
USER DEFINED	53		
USER DEFINED	54		
NET SounderA	55		
USER DEFINED	56		
USER DEFINED	57		
USER DEFINED	58		
USER DEFINED	59		
USER DEFINED	60		
USER DEFINED	61		
USER DEFINED	62		
USER DEFINED	63		
USER DEFINED	64		
NET F.P.E.A	65		
Undefine	66		
Loop SW	67		
Loop Board	68		
CONTROL Panel	69		
ZoneDir Board	70		
AC Power	71		
Battery	72		
Keypad Board	73		
Ground.F	74		
Undefine	75		
Loop Short	76		
Loop Board	77		
Delay Mode	78		
Power Board	79		
CRT Board	80		
F.P.E.A	81		
SounderA	82		

SUPERVISORY

ACTION

PANEL

ALARM ROUTINGA	83	
Loop Flash Data	84	
Undefine	85	
Panel charger	86	
BAT Resistance	87	
Undefine	88	
Undefine	89	
Undefine	90	
Undefine	91	
Undefine	92	
Undefine	93	
Undefine	94	
Undefine	95	
Undefine	96	
Undefine	97	
Undefine	98	
Undefine	99	

Appendix 4: Index of Information Required by EN54-2

EN54-2 Clause 12.2		Chapters or sections in this manual
12.2.1.a	General description of the equipment	Chapter 1
	Optional functions with requirements of EN54-2, functions relating to EN54-4, ancillary functions not required by EN54-2	Preface
12.2.1.b	Power requirement for recommended operation	Section 2.1, 2.2
	Maximum capacity per detection circuit	Section 2.4
	Maximum capacity per FACP	Chapter 1
	Electrical ratings for inputs and outputs	Section 2.5
	Communication parameters on transmission paths	Section 2.4, 2.5
	Fuse ratings	Section 8.2
12.2.1.c	Installation information	Section 4.1, 4.2, 4.3, 4.4
12.2.1.d	Configuring and commissioning instructions	Section 4.5, 4.6, 4.7
12.2.1.e	Operating instructions	Chapter 6
12.2.1.f	Maintenance information	Chapter 8

Operation Following an Alarm or Fault Condition

FIRE Alarm Tone and Red LED

Fire	Sum:001			
001: 13 Jan	10:01	Zone 001	Sum001/002	[√]
Second Floor				
→Press [Enter] to view details				
→Press [L/R Scroll] to switch inf. type				
Last Fire:	13Jan	10:01	Zone001	[√]
Second Floor				
FAR:ON	FPE:ON	OTS:ON	10:20:01	

1. Open the door. LCD screen displays: The first, and in multiple alarm condition also the last fire, time and **zone location**. Fire LED turn on steady and corresponding zone indication.
2. Press ENTER to view the device loop, address, device type and location
3. To view all fire events press key ▲ and ▼ (Up and Down cursor to scroll)

Fire	Zone:001	Sum:001		
001: 13 Jan	10:01	L01D002	MCP	(BG)
Corridor Left Wing				
→Press [F1] to disable device				
→Press [L/R Scroll] to switch inf. type				
Last Fire:	13Jan	10:01	Zone001	[√]
Second Floor				
FAR:ON	FPE:ON	OTS:ON	10:20:01	

Silencing the panel and signal

1. Silence the control panel
Press the 'MUTE' Button and the MUTE LED turn on steady
2. Silencing the sounder signal
Press the "Silence" Button and the corresponding key LED illuminates

Resetting the system

1. When the alarm condition has been cleared, restore and replace all affected devices in accordance with the details provided with each device.
2. Reset the system

In fire mode. Press 'RESET' key.

Display show "Please Input Password: ____" input After reset the display should shows " System Running"

FAULT

Alarm Tone and Yellow LED

```

Fault          Sum:001
001: 13 Jan   10:01   Zone 001   Sum001/002 [√]
Second Floor
  
```

→Press [Enter] to view details

```

FAR:OK   FPE:OK   OTS:OK           10:20:01
  
```

1. Open the door. LCD screen displays: The first, and in multiple alarm condition also the last fault, time and **zone location**. Fault LED turn on steady and corresponding zone indication.
2. Silence the panel, press the "MUTE" and the MUTE LED turn on steady.
3. Press ENTER to view the device loop, address, device type and location
4. To view all fault events press key ▲ and ▼ (Up and Down cursor to scroll)

```

Fault          Sum:001
001: 13 Jan   10:01   L01D003   Multi Sensor
NRT Training Room
  
```

→Press [F1] to disable device

```

FAR:OK   FPE:OK   OTS:OK           10:20:01
  
```

Check the fault, restore or replace the defective device. Isolate the fault during analysis if necessary.

Disable the device

1. Press "F1" then Input Password: ____.
2. Confirm by pressing "Enter" and the Disable yellow LED turn on steady.

Enable the device

1. Press ► or ◀, Then F1 and follow the display instruction
2. Disable LED turns off once it is confirmed

Resetting the system

1. On Fault mode. Press 'RESET" key
2. Display show "Enter Password: ____" input the code. Press "Enter"

Note: Disable can be rested only by Enable operation
The display show "Panel Healthy With Disable"



A UTC Fire & Security Company

Global System Technology PLC

Lion Court, Staunton Harold Hall,
Melbourne Road, Ashby de la Zouch,
Leicestershire,
England LE65 1RT
Tel: +44 1283 225 478
Fax: +44 1283 220 690

Email: info@gst.uk.com
www.gst.uk.com

Global System Technology PLC

PO Box 17998 Unit ZA04 JEBEL ALI Free Zone,
Dubai, UAE
Tel: +971 (0) 4 8833050
Fax: +971 (0) 4 8833053

Email: info@gst.uk.com
www.gst.uk.com