

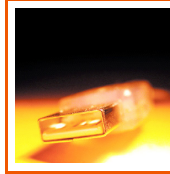

SMSCTM
SUCCESS BY DESIGN

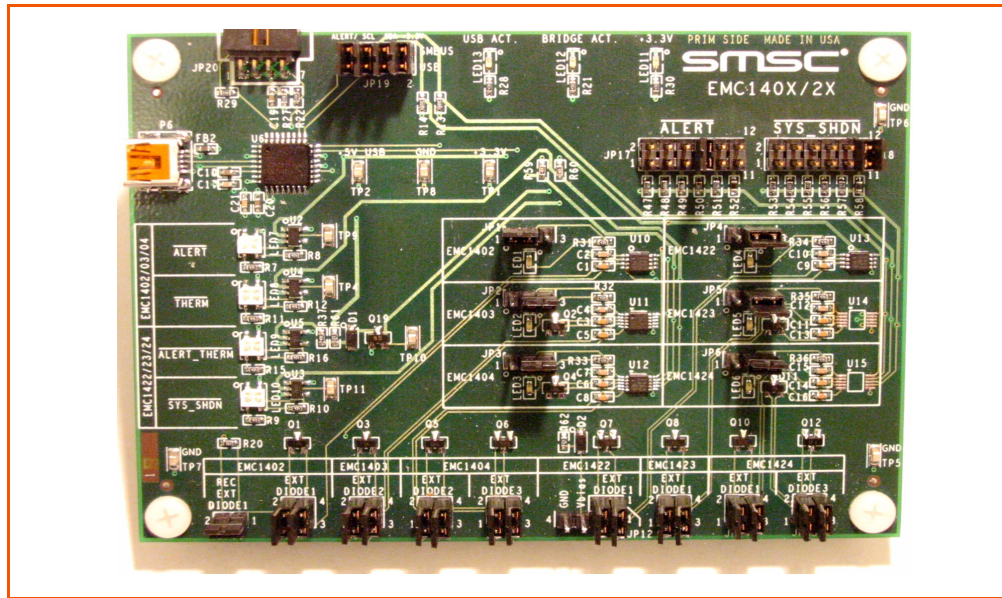

EVB-EMC14XX User Manual



The information contained herein is proprietary to SMSC, and shall be used solely in accordance with the agreement pursuant to which it is provided. Although the information is believed to be accurate, no responsibility is assumed for inaccuracies. SMSC reserves the right to make changes to this document and to specifications and product descriptions at any time without notice. Neither the provision of this information nor the sale of the described semiconductor devices conveys any licenses under any patent rights or other intellectual property rights of SMSC or others, unless specifically specified otherwise. The product may contain design defects or errors known as anomalies, including but not necessarily limited to any which may be identified in this document, which may cause the product to deviate from published specifications. SMSC products are not designed, intended, authorized or warranted for use in any life support or other application where product failure could cause or contribute to personal injury or severe property damage. Any and all such uses without prior written approval of an officer of SMSC will be fully at the risk of the customer. SMSC is a registered trademark of Standard Microsystems Corporation ("SMSC").

SMSC DISCLAIMS AND EXCLUDES ANY AND ALL WARRANTIES, INCLUDING WITHOUT LIMITATION ANY AND ALL IMPLIED WARRANTIES OF MERCHANTABILITY, FITNESS FOR A PARTICULAR PURPOSE, TITLE, AND AGAINST INFRINGEMENT AND THE LIKE, AND ANY AND ALL WARRANTIES ARISING FROM ANY COURSE OF DEALING OR USAGE OF TRADE. IN NO EVENT SHALL SMSC BE LIABLE FOR ANY DIRECT, INCIDENTAL, INDIRECT, SPECIAL, PUNITIVE, OR CONSEQUENTIAL DAMAGES; OR FOR LOST DATA, PROFITS, SAVINGS OR REVENUES OF ANY KIND; REGARDLESS OF THE FORM OF ACTION, WHETHER BASED ON CONTRACT; TORT; NEGLIGENCE OF SMSC OR OTHERS; STRICT LIABILITY; BREACH OF WARRANTY; OR OTHERWISE; WHETHER OR NOT ANY REMEDY OF BUYER IS HELD TO HAVE FAILED OF ITS ESSENTIAL PURPOSE, AND WHETHER OR NOT SMSC HAS BEEN ADVISED OF THE POSSIBILITY OF SUCH DAMAGES.

1 Overview

The EMC140X series of devices are SMBus temperature sensors with $\overline{\text{THERM}}$ and $\overline{\text{ALERT}}$ outputs. The EMC142X series of devices have Hardware Thermal Shutdown outputs in place of $\overline{\text{THERM}}$. The EMC1402 and EMC1422 each monitor one internal diode and one externally connected temperature diode. The EMC1403 and EMC1423 each monitor one internal diode and two externally connected temperature diodes. And finally, the EMC1404 and EMC1424 each monitor one internal diode and up to three externally connected temperature diodes.

All of the modes and functions of the EMC140X/2X can be tested and observed with the EVB-EMC14XX. The EVB-EMC14XX is a USB-based platform for evaluating all variations of the EMC140X/2X. A block diagram of this EVB is shown in [Figure 1.1](#).

1.1 Related Documents

The CD included with the evaluation board contains the following documents:

- n Evaluation Board Checklist
- n Bill Of Materials
- n Schematic
- n Jumper Settings and Connector List
- n Datasheets
- n Chip Manager Application
- n Chip Manager Register Definition Files (EMC1402.xml, EMC1403.xml, EMC1404.xml, EMC1422.xml, EMC1423.xml, and EMC1424.xml)

Figure 1.1 EVB-EMC14XX Block Diagram

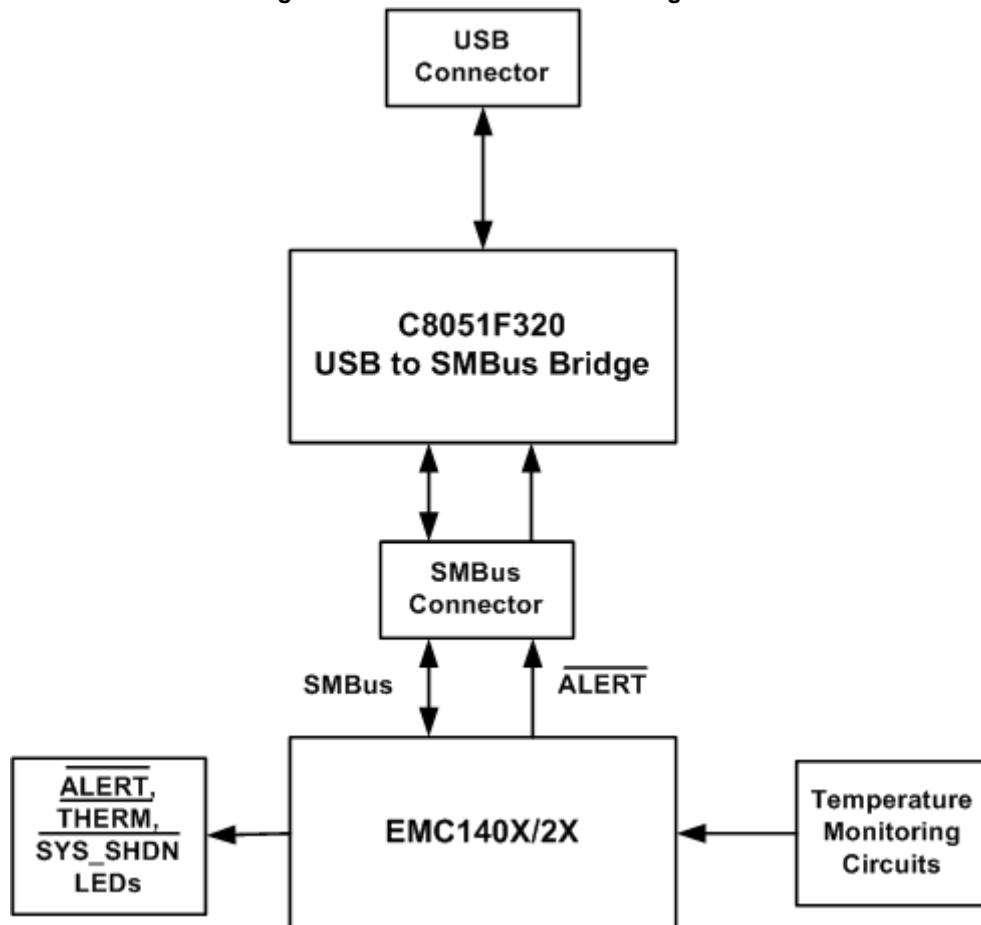

2 Getting Started

2.1 System Requirements

To use the EVB you will need:

- n A PC running Windows 2000 or XP
- n Display resolution 800x600 (or larger to view several windows simultaneously)
- n An available USB port

2.2 Feature Summary

- n The SMSC Chip Manager (ChipMan) application allows viewing and changing register values
- n Graphing of any register
- n Headers for connecting a remote diode or CPU/GPU
- n Resistance Error Correction verification
- n Saving of settings of all registers allowing for quick loading at a later time
- n USB communication to evaluation board
- n An external SMBus master may also be used via jumper settings

2.3 Installing the EVB

1. Install the Chip Manager application and device driver on a PC by running Setup.exe from the Chip Manager distribution CD. A revision history and install/un-install notes may be found in the readme.txt file on the disk.
2. Connect the supplied USB cable to an available USB port on the PC. Plug the “mini-B” end of the USB cable into EVB connector P6. The +3.3V and Bridge ACT LEDs should illuminate. After the EVB is connected to the PC the “Find New Hardware” wizard will pop up for USB driver installation. Follow the instructions in the readme.txt file to complete the installation process.
3. Start the EVB Software by selecting the Chip Manager application from the SMSC folder from the Programs Windows Start menu. The EVB will initialize and the Chip Manager Quick Help screen will appear as in [Figure 2.1](#). The USBAct LED should be blinking when the Chip Manager is running. For more help with Chip Manager, select Help -> Contents for an html based help document as shown in [Figure 2.2](#).

Note: The SMSC Chip Manager application allows viewing and changing register values for a variety of EVBs including the EMC1001, EMC1002, EMC1023, EMC1033 and EMC2101. The Chip Manager software only needs to be installed once to support all of these EVBs. The list of supported EVBs may be found in the pulldown menu under Options -> Select Device.

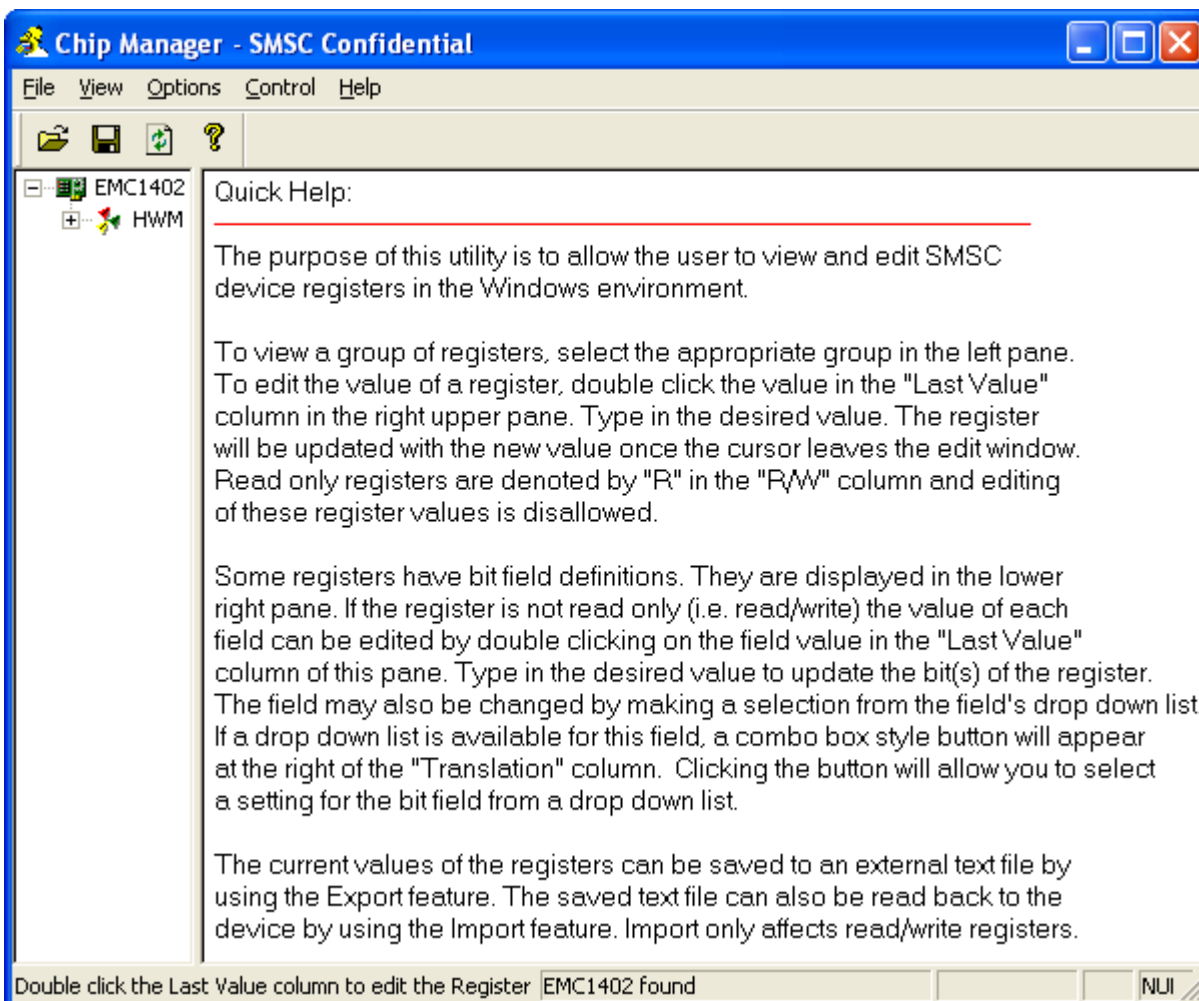

Figure 2.1 Chip Manager Quick Help Startup Screen

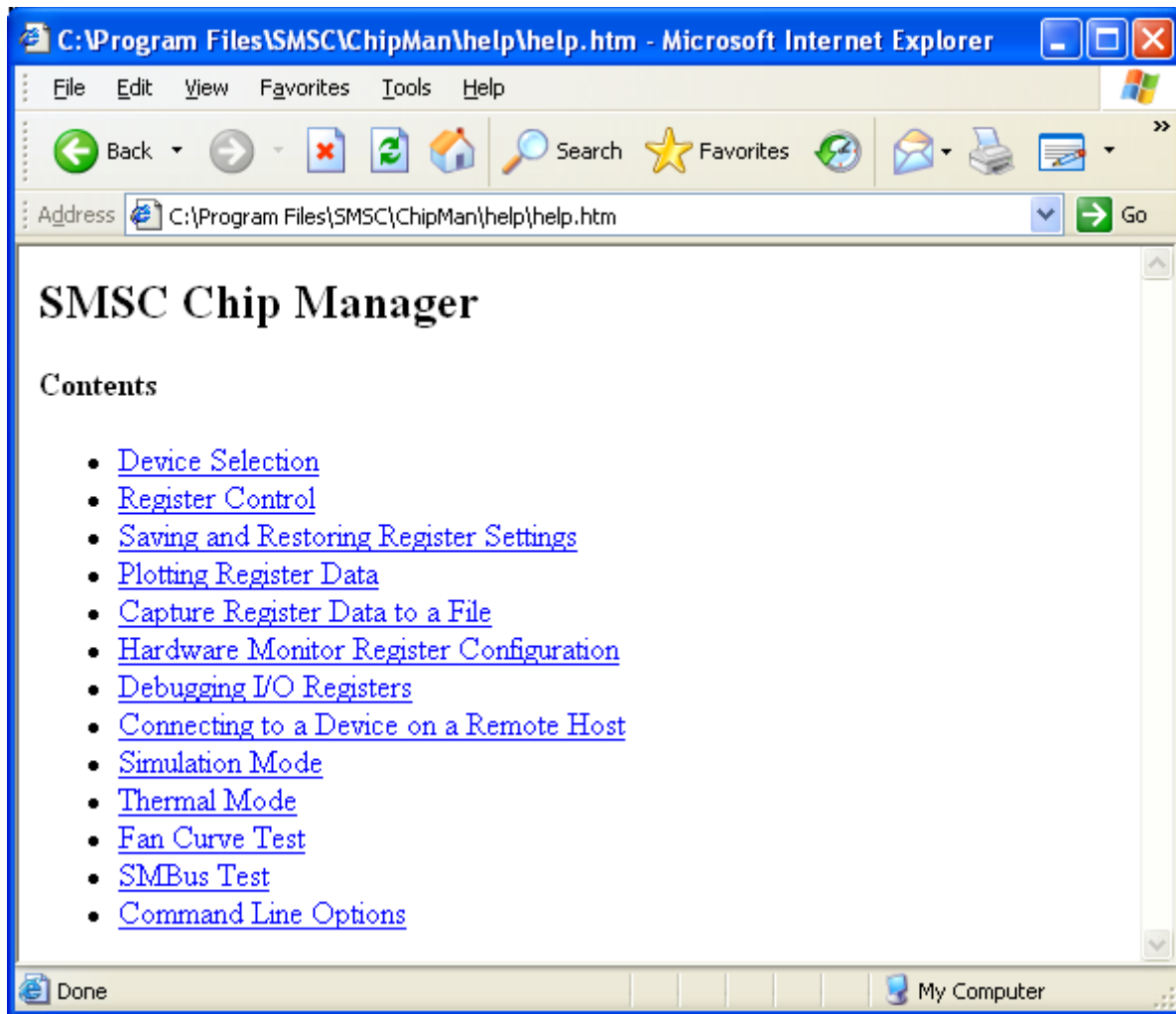

Figure 2.2 Chip Manager Help Screen

3 Hardware Description

3.1 Introduction

The EVB-EMC14XX provides the means to demonstrate all of the EMC140X/2X features and to view and modify registers. LEDs indicate status information and test points are included to monitor system voltages with a user provided voltmeter or oscilloscope.

3.2 EMC140X/2X Devices

A total of four of six SMSC devices are on-board the EVB-EMC14XX. Jumpers enable which version is active on the EVB. Please contact SMSC for boards with the EMC1423 or EMC1424 devices.

3.3 USB to SMBus Bridge

The USB to SMBus bridge is based on an 8051 micro controller with integrated USB and SMBus interfaces as well as internal flash and RAM. During EVB manufacture, firmware is loaded into the bridge that provides the interface between the USB and the SMBus. Power is sourced to the micro controller from the USB interface for device power and communication.

3.3.1 Direct SMBus Connect Option

It is also possible to connect an external SMBus master to the EVB-EMC14XX. A few jumper settings are all that is required to drive the any one of the devices on-board the EVB:

- Simply remove the jumpers on JP6 and connect the SMBus master to the SCL, SDA and $\overline{\text{ALERT}}$ pins, as well as an external supply for +3.3V.
- The +3.3V can be supplied by the SMBus bridge by leaving the +3.3V jumper in place and retaining the USB connection.

3.4 Connecting to Remote Diodes

This EVB is populated with jumpers to connect to an external diode or CPU/GPU. If connecting to a CPU's thermal diode, it is necessary to provide a common ground. Also, it is usually necessary to bias the appropriate CPU Vcc plane above this common ground to avoid forward-biasing the ESD diodes with the temperature sensor signals. These connections have been provided on JP11 which is read by EMC1422. Consult the CPU manufacturer's datasheet for guidance on interfacing to the thermal diode. Refer to the schematic EMC14XX_EVB_SCH-7092-A.pdf for details on the EVB header connections.

3.5 Resistance Error Correction (REC)

The remote diode DN signal path has a 100 ohm series resistor to demonstrate the EMC140X/2X's REC feature. See [Table 3.3](#) for details on the REC jumper settings.

3.6 Power Source

This EVB requires only one USB connection to power the entire board. The USB-SMBus bridge regulates the +5V USB power to +3.3V used by the EMC140X/2X and other EVB circuitry.

3.7 Test Points

Test points are provided for:

- Ground
- +3.3V power
- +5V_USB power
- $\overline{\text{ALERT}}$, $\overline{\text{THERM}}$, and $\overline{\text{SYS_SHDN}}$ outputs

3.8 LED Indicators

LEDs indicate the status of the following signals ([Table 3.1](#)).

Table 3.1 LED Status Indicators

LED	SIGNAL	OFF	GREEN	RED
LED1	$\overline{\text{ALERT}}$	+3.3V power OFF	No $\overline{\text{ALERT}}$	$\overline{\text{ALERT}}$
LED2	+3.3V	+3.3V power OFF	+3.3V power ON	NA
LED3	Bridge Activity	NO Activity on USB/SMBus Bridge	Activity on USB/SMBus Bridge	NA
LED4	USB Activity	NO Activity on USB port	Activity on USB port	NA
LED5	$\overline{\text{SYS_SHDN}}$	+3.3V power OFF	No $\overline{\text{SYS_SHDN}}$	$\overline{\text{SYS_SHDN}}$
LED6	$\overline{\text{THERM}}$	+3.3V power OFF	No $\overline{\text{THERM}}$	$\overline{\text{THERM}}$
LED7	$\overline{\text{ALERT/THERM}}$	+3.3V power OFF	No $\overline{\text{ALERT/THERM}}$	$\overline{\text{ALERT/THERM}}$
LED02	EMC1402 power	device OFF	device ON	NA
LED03	EMC1403 power	device OFF	device ON	NA
LED04	EMC1404 power	device OFF	device ON	NA
LED22	EMC1422 power	device OFF	device ON	NA
LED23	EMC1423 power	device OFF	device ON	NA
LED24	EMC1424 power	device OFF	device ON	NA

3.9 Jumper Settings

This EVB has many jumper configurations to evaluate all of the features of the EMC140X/2X family of devices.

The first jumper the user should connect is the device enable jumper. This jumper will determine which of the 6 devices will be powered up and evaluated.

Table 3.2 Device Selection Jumpers

DEVICE	ENABLE	DISABLE
EMC1402	JP1: short 1-2	JP1: short 2-3
EMC1403	JP2: short 1-2	JP2: short 2-3
EMC1404	JP3: short 1-2	JP3: short 2-3
EMC1422	JP4: short 1-2	JP4: short 2-3
EMC1423	JP5: short 1-2	JP5: short 2-3
EMC1424	JP6: short 1-2	JP6: short 2-3

The remote diode on board the EVB-EMC14XX has an in-line series resistance adjustment. Checking the REC (Resistance Error Correction) feature of the EMC1402 is accomplished by setting the jumper on JP16 as shown in [Table 3.3](#). An open jumper adds 100 ohms of series resistance to the DN line of the diode connection. To return to 0 ohm series resistance, replace the jumper on JP16. This feature

is demonstrated on the EMC1402 only. However, each device of the EMC140X/2X family has this feature.

Table 3.3 Resistance Error Correction

JUMPER	NAME	OPEN	SHORT
JP16	REC	100 ohms in DN line (diode remote -)	0 ohms in DN line (diode remote -)

This EVB also allows for an off-board diode to be tested (see [Table 3.4](#)). This is done by removing both jumpers of the device of interest. Then connect Pin 1 to the 'remote+' terminal of the remote diode and Pin 3 to the 'remote-' terminal of the remote diode. Make sure a common ground exists between the remote diode (GPU, etc.) and the EMC140X/2X EVB. Also ensure that the remote diode is properly biased according to the diode manufacture. One remote connection is provided per EMC140X/2X device.

Table 3.4 Remote Diode Configurations

JUMPER	CONFIGURATION	PIN 1	PIN 2	PIN 3	PIN 4
JP7	On-board diode EMC1402 (Q1)	short / DP		short / DN	
	Off-board diode (CPU, GPU, etc.)	remote + / DP	open	remote - / DN	open
JP8	On-board diode EMC1403 (Q3)	short / DP		short / DN	
	Off-board diode (CPU, GPU, etc.)	remote + / DP	open	remote - / DN	open
JP9	On-board diode EMC1404 (Q5)	short / DP		short / DN	
	Off-board diode (CPU, GPU, etc.)	remote + / DP	open	remote - / DN	open
JP10	On-board diode EMC1404 (Q6)	short / DP		short / DN	
	Off-board diode (CPU, GPU, etc.)	remote + / DP	open	remote - / DN	open
JP13	On-board diode EMC1423 (Q8)	short / DP		short / DN	
	Off-board diode (CPU, GPU, etc.)	remote + / DP	open	remote - / DN	open
JP14	On-board diode EMC1424 (Q10)	short / DP		short / DN	
	Off-board diode (CPU, GPU, etc.)	remote + / DP	open	remote - / DN	open
JP15	On-board diode EMC1424 (Q12)	short / DP		short / DN	
	Off-board diode (CPU, GPU, etc.)	remote + / DP	open	remote - / DN	open

Table 3.5 EMC1422 Off-board Diode Connections

CONFIGURATION	JUMPER	PIN 1	PIN 2	PIN 3	PIN 4
On-board diode EMC1422 (Q7)	JP12	Short / DP	Short / DN	NA	NA
	JP11			NA	NA

CONFIGURATION	JUMPER	PIN 1	PIN 2	PIN 3	PIN 4
Off-board diode (CPU, GPU, etc.)	JP12	Open	Open	NA	NA
	JP11	remote + / DP	remote - / DN	Vbias	GND



A unique feature of the EMC142X series of devices is the ability to select the Hardware System shutdown temperature based on the pull up resistor on the ALERT and SYS_SHDN outputs. The EVB allows the user to quickly evaluate each of the 36 temperature values by adjusting JP18 and JP17 as shown in [Table 3.6](#).

Table 3.6 ALERT and SYS_SHDN Resistor Selection for SYS_SHDN Temperature

<u>SYS_SHDN</u> PULL-UP <u>ALERT</u> PULL-UP	R53 JP18: 1-2 4.7K OHM ±10%	R54 JP18: 3-4 6.8K OHM ±10%	R55 JP18: 5-6 10K OHM ±10%	R56 JP18: 7-8 15K OHM ±10%	R57 JP18: 9-10 22K OHM ±10%	R58 JP18: 11-12 33K OHM ±10%
R47 JP17: 1-2 4.7K OHM ±10%	77°C	83°C	89°C	95°C	101°C	107°C
R48 JP17: 3-4 6.8K OHM ±10%	78°C	84°C	90°C	96°C	102°C	108°C
R49 JP17: 5-6 10K OHM ±10%	79°C	85°C	91°C	97°C	103°C	109°C
R50 JP17: 7-8 15K OHM ±10%	80°C	86°C	92°C	98°C	104°C	110°C
R51 JP17: 9-10 22K OHM ±10%	81°C	87°C	93°C	99°C	105°C	111°C
R52 JP17: 11-12 33K OHM ±10%	82°C	88°C	94°C	100°C	106°C	112°C

3.10 Default Jumper Settings

Table 3.7 Default Jumper Settings

JUMPER	NAME	CONNECTION	DESCRIPTION
JP1	EMC1402 Power	1 - 2 2 3	Power on EMC1402 Turn off EMC1402
JP2	EMC1403 Power	1 2 2 - 3	Power on EMC1403 Turn off EMC1403
JP3	EMC1404 Power	1 2 2 - 3	Power on EMC1404 Turn off EMC1404
JP4	EMC1422 Power	1 2 2 - 3	Power on EMC1422 Turn off EMC1422
JP5	EMC1423 Power	1 2 2 - 3	Power on EMC1423 Turn off EMC1423
JP6	EMC1424 Power	1 2 2 - 3	Power on EMC1424 Turn off EMC1424
JP7	EMC1402 off-board diode	1 - 2 3 - 4	DP connection DN connection
JP8	EMC1403 off-board diode	1 - 2 3 - 4	DP connection DN connection
JP9	EMC1404 off-board diode	1 - 2 3 - 4	DP connection DN connection
JP10	EMC1404 off-board diode	1 - 2 3 - 4	DN connection for anti-parallel diode DP connection for anti-parallel diode
JP11/JP12	EMC1422 off-board diode	JP12.1 - JP11.1 JP12.2 - JP11.2 JP11.3 JP11.4	DP connection DN connection Vbias ~ +0.7V Ground
JP13	EMC1423 off-board diode	1 - 2 3 - 4	DP connection DN connection
JP14	EMC1424 off-board diode	1 - 2 3 - 4	DP connection DN connection
JP15	EMC1424 off-board diode	1 - 2 3 - 4	DN connection for anti-parallel diode DP connection for anti-parallel diode
JP16	REC	1 - 2 *	IN = 0 ohms, OUT = 100 ohms in

JUMPER	NAME	CONNECTION	DESCRIPTION
JP17	$\overline{\text{ALERT}}$ pull-up	1 - 2 3 4 5 6 7 8 9 10 11 12	Select 4.7k ohm resistor Select 6.8k ohm resistor Select 10k ohm resistor Select 15k ohm resistor Select 22k ohm resistor Select 33k ohm resistor
JP18	$\overline{\text{SYS_SHDN}}$ pull-up	1 - 2 3 4 5 6 7 8 9 10 11 12	Select 4.7k ohm resistor Select 6.8k ohm resistor Select 10k ohm resistor Select 15k ohm resistor Select 22k ohm resistor Select 33k ohm resistor
JP19	USB to SMBus	1 - 2 3 - 4 5 - 6 7 - 8	+3.3V SDA - SMBus SCL - SMBus $\overline{\text{ALERT}}$
JP20	Flash Prog Header	NA	Used in manufacturing

Note: dashed line indicates jumper position

3.11 Other Sensor Features

Other features such as Ideality Factor Configuration, Conversion Rate, Digital Filtering, and Standby Mode can be controlled with EMC140X/2X registers. See the datasheet register description for details.

4 Software Description

4.1 Chip Manager Overview

The Chip Manager (ChipMan) application initially displays the main Help screen, where detailed description of the application's features may be found. The Help screens can be displayed at any time by selecting Help from the menubar. Chip Manager enables the user to display temperature readings, set temperature limits and read/write configuration register values.

4.2 Temperature/Register History Graph

To open a Temperature or Register History Graph window, select the register or registers to plot in the Chip Manager application. then select Options -> Plot Register Data from the menubar. Once the graph appears, select Control -> Start to begin plotting data. The history plot continuously updates the register data reported by the EMC140X/2X. [Figure 4.1](#) below is a typical Temperature History with the external diode of the EMC1402 starting at room temp and then being heated by simply placing a finger on Q1.:

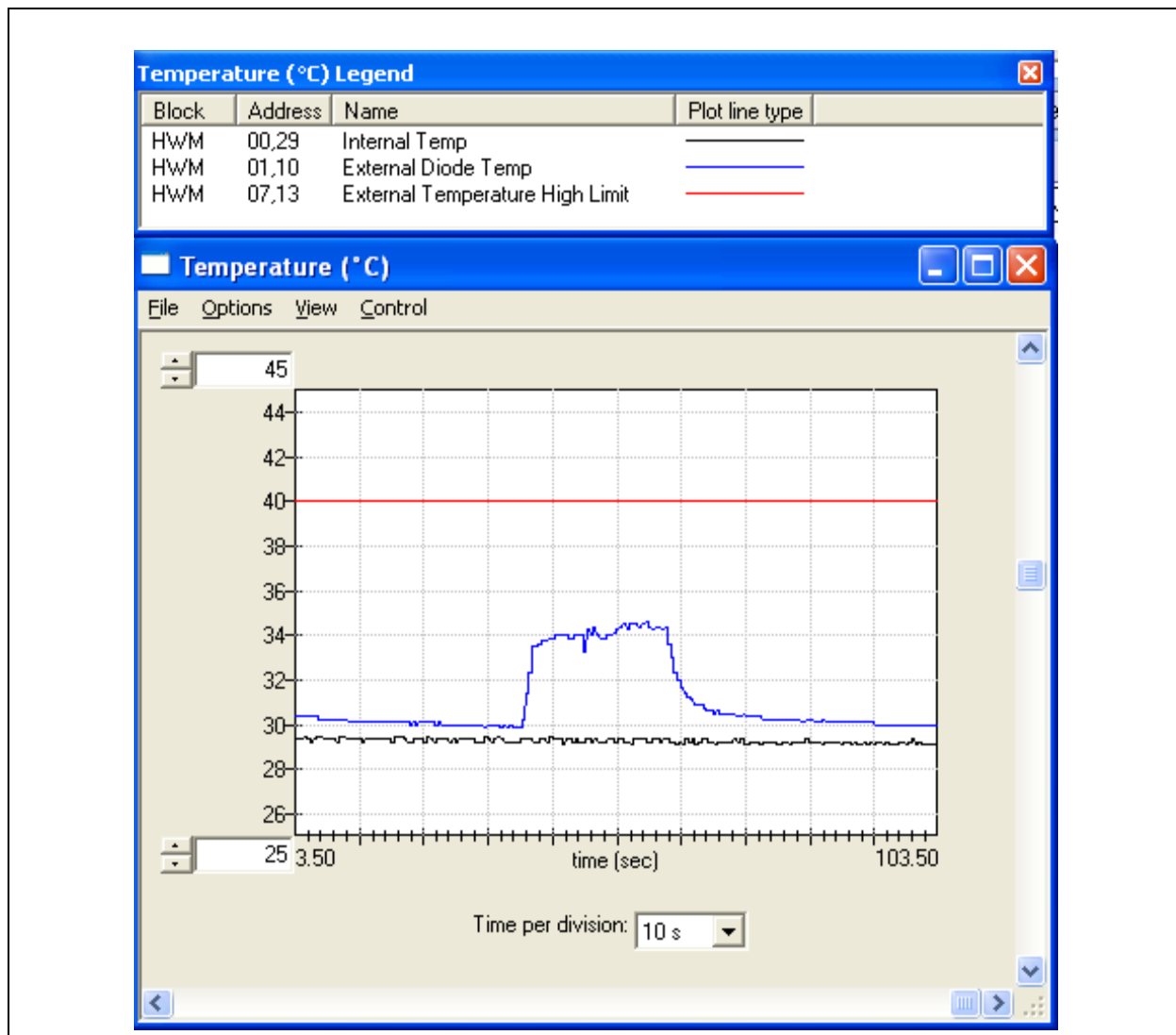

Figure 4.1 EMC140X/2X Temperature History Graph

Mouser Electronics

Authorized Distributor

Click to View Pricing, Inventory, Delivery & Lifecycle Information:

SMSC:

[EVB-EMC14XX](#)