



JTG JT300

USER MANUAL



Welcome to JTG!

Thank you for the confidence you have shown in our brand by purchasing this motorcycle designed for Trial.

As a JTG user, you will enjoy a product that offers innovation where strictly necessary, without excesses, incorporating characteristics such as quality, prestige and exclusivity.

Designed by off-road professionals to offer comfortable and effective service without forgetting a competitive spirit, that will enable you to experience the performance of a winner, ready at your disposal.

JOTAGAS S.L. 2012

JTG ADVISES YOU:

Please read this user manual carefully before using your motorcycle. In it you will find all the instructions necessary for correct operation of the machine as well as for your own safety, enabling you to attain optimum maintenance and service life from the very first day.

Please pay special attention to notes bearing these symbols:



ATTENTION! This symbol refers to aspects which if ignored could cause damage to your motorcycle. Non-observance of these warnings could render the guarantee void.



PRECAUTION! This symbol refers to aspects which if ignored could result in physical danger to the user.

In addition to the specific warning notes, this manual also contains other tips for better use of your motorcycle as well as better adjustment and control of important features of the vehicle.

JTG reserves the right to modify this manual.

JTG RECOMMENDS:

- In case of any doubt as to possible adjustments of your motorcycle, please follow the instructions contained in this manual and/or contact an authorised JTG dealer.
- Please read the information contained in this user manual and familiarise yourself with the features of your vehicle before driving it at maximum power.
- It is recommended to establish an initial running-in period of at least 8-10 hours for the engine to bed in, during this period do not drive at high speed or full throttle. The first hours of use should be at moderate speed only.
- Fuel is highly inflammable. Take care when refuelling and always stop the engine first.
- Before running the engine at high speed, it is important to have reached an optimum operating temperature, especially when starting up the motorcycle or in low temperature conditions.
- This motorcycle uses synthetic two-stroke oil mixed with 98-octane fuel in a 1% proportion. Do not use any other type of lubrication without first consulting with an authorised JTG mechanic.
- This motorcycle is designed to carry only one person; it is not permitted to carry a passenger.
- For the longest possible service life, keep the motorcycle maintained according to the recommendations in this manual.
- This vehicle has been designed for safe riding, as long as the rider is equipped with the necessary safety gear (Helmet, body protection, etc.). Take care and ride in a sensible manner.

TABLE OF CONTENTS

Description of parts	7	Sparkplug	21
Technical datasheet	9	Cooling system	22
Vehicle information	11	Carburettor	23
Starting and stopping the engine	12	Adjusting the tick over	24
The choke	12	Reed valve box	25
Gear change	13	Transmission chain	25
Fuel tap	13	Suspension	26
Fuel tank	14	Swing arm	27
Tyres	15	Maintaining the motorcycle	28
Brakes	16	Speedometer	29
Steering lock	17	Torque values	33
Side stand	17	Storage	34
Handlebar and instrument panel	18	Maintenance operations	35
Adjusting levers and the handlebar	19	Homologation	39
Checking the oil level	19	Troubleshooting	40
Air filter	20		

DESCRIPTION OF PARTS

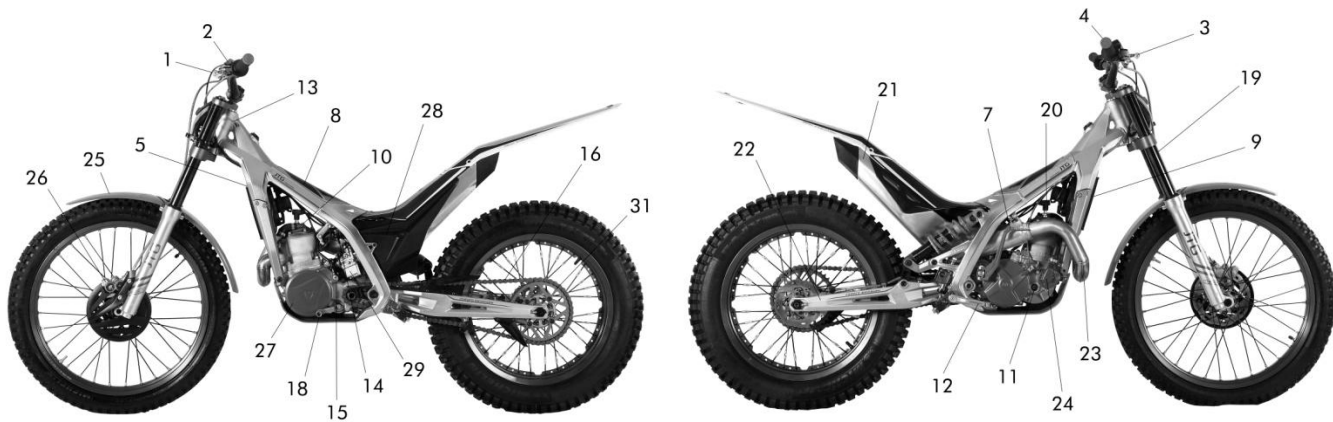

1- Clutch lever

2- Indicator, horn and stop buttons

3- Brake lever

4- Accelerator

5- Radiator cap

6- Fuel tank cap

7- Starting pedal

8- Fuel tank

9- Radiator

10- Radiator drainage bolt

11- Sump oil level peep hole

12- Rear brake pedal

13- Engine breather

14- Fuel tap

15- Reed valve

16- Transmission chain

18- Gear change pedal

19- Front fork

20- Spark plug

21- Silencer

22- Swing arm

23- Exhaust pipe

24- Water pump

25- Front mudguard

26- Front brake caliper

27- Ignition cover

28- Air filter cover

29- Carburettor

30- Centre stand

31- Rear sprocket

32- Speedometer

33- Front suspension adjustment

34- Footrests

35- Rear mudguard

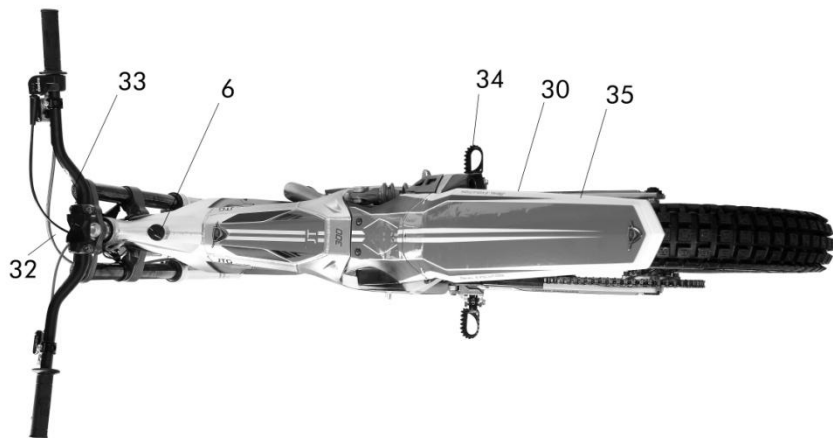

TECHNICAL DATASHEET

CHASSIS

Type: Double beam with lateral suspension system and built-in fuel tank

TYRES

Front: 2.75 x 21" - 44 (160 kg) L

Rear: 4.00 x 18" - 52 (200 kg) - L

SUSPENSION

Front: TECH Hydraulic telescopic fork COM-EX \varnothing 39 mm (175 mm travel)

Rear: V3 progressive system with OLLE mono adjustable shock absorber (175mm travel)

BRAKES

Front: Disc, \varnothing 185 mm, 4-piston caliper

Rear: Disc, \varnothing 150 mm, 2-piston caliper

ENGINE

Type: Two-stroke, single cylinder, reed valve admission directly to the engine block, liquid cooled.

Cubic capacity: 301.58 cc

Piston diameter: 80 mm

Stroke: 60 mm

Carburettor: DELLORTO PHBL26

Lubrication system: 1% mixture (1:100)

Ignition: Digital CDI HIDRIA

Spark plug: NGK BPMR6A

Generator: 12V / 110W

TRANSMISSION

Type: 5-speed with hydraulically operated clutch.

Secondary transmission: Chain.

Gear ratios:

1st 3.000 (33/11)

2nd 2.571 (36/14)

3rd 2.187 (35/16)

4th 1.444 (26/18)

5th 0.889 (24/27)

Primary reduction 2.778 (75/27)

Final reduction 4 (40/10)

Total ratio (5th gear): 9.879

Transmission oil: 400 cc, type GEAR TRANS 0W75

DIMENSIONS

Overall height: 1160 mm

Overall width: 833 mm

Seat height: 650 mm

Wheelbase: 1180 mm

Fuel capacity: 2.7 litres

Dry weight: 64 kg

VEHICLE INFORMATION

MANUFACTURER'S IDENTIFICATION PLATE (Under the fuel tank)

This plate contains information regarding vehicle certification, take note of this for easy identification of your vehicle, when needed.

SERIAL NUMBER AND KEY CODE

These numbers identify your motorcycle and the steering lock, take note of them in this manual (e.g. for ordering new keys if you lose them).



We recommend you take note of the serial number and identification data of your motorcycle for use in case of theft or to order spare parts.



- 1- MANUFACTURER'S IDENTIFICATION PLATE
- 2- CHASSIS NUMBER
- 3- KEY CODE

(Supplied with the keys)

STARTING AND STOPPING THE ENGINE

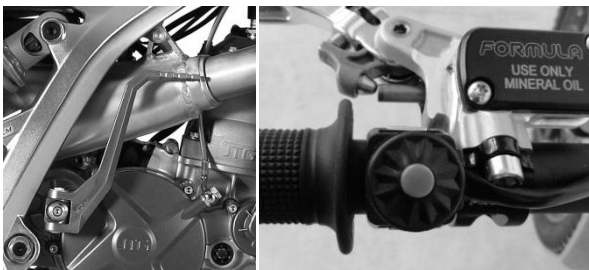

To start the motorcycle, first make sure that the fuel tap is open and that the gearbox is in neutral or if not, that the clutch lever is pulled in.

Then push the starting pedal, located on the right-hand side of the motorcycle. It will also be necessary to use the choke when starting from cold.

To stop the engine, select neutral and press the stop button on the handlebar.

THE CHOKE

Use the choke when the engine is cold to start without causing damage to the engine. This device, when used properly, will avoid excessive wear and mechanical damage when starting in cold temperature. To activate it, lift the black lever on the carburettor.



GEAR CHANGE

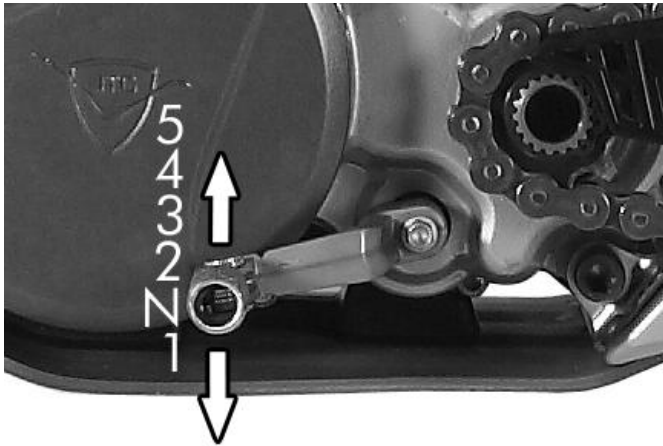

The gear change is controlled by a pedal on the left-hand side of the vehicle, the sequence is as indicated in the illustration. **At the same time as you change gears you must disengage the clutch by pulling in the clutch lever on the left-hand side of the handlebar.** The gearbox is sequential, i.e., to change from 2nd to 4th gear you must first go through 3rd gear.

FUEL TAP



The fuel tap is under the fuel tank.

For the fuel to flow, the tap must be in the ON position. For reserve, select the RES position and to shut of the flow, leave the tap lever in an intermediate position between ON and RES.

FUEL TANK



This motorcycle's fuel tank is built into the chassis, more specifically the upper part of the chassis. It holds 2.7 litres of fuel which should be lead free petrol with two-stroke oil in the proportions specified on the technical datasheet. The tank cap is at the top of the tank.

Petrol minimum octane rating: 98 octanes



Important. Do not mix vegetable and mineral oil. Respect the specified levels and proportions for correct combustion. For a homogeneous mix, first pour the oil into a container and add some petrol, shake and then add the mixture to the rest of the petrol. Avoid mixing at low temperature, as this will make the operation more difficult.

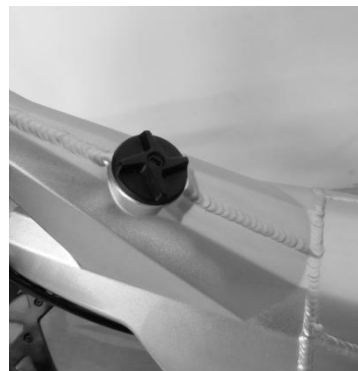

TYRES



Tyres in good state will significantly contribute to your safety and will guarantee better driving behaviour. Make sure the pressures are correct at all times and check for wear. Pressure should be measured when the tyre is cold.

TYRES

Front wheel:

2.75 x 21" TRIAL

Rear wheel:

4.00 x 18" TRIAL

RECOMMENDED TYRE PRESSURES

Front wheel:

0.45 bar (0.42 bar for competition)

Rear wheel:

0.35 bar (0.3 bar for competition)

When riding on low adherence terrain, you can reduce the pressure slightly in order to favour adhesion and vice-versa.

BRAKES

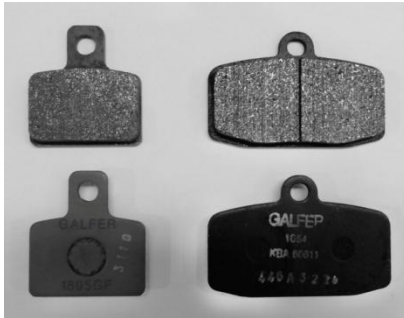

You should regularly check the state of the front and rear brake pads as well as the brake fluid level. For your safety as well as precise and effective riding, do not use the motorcycle with excessively worn brake pads or brake fluid below the minimum level. If the brake pedal has a spongy feel, there may be air in the hydraulic system and it will need to be bled.



The brake fluid level can be checked through the peephole on the front master cylinder and the fluid reservoir of the rear master cylinder. The level must reach the middle, fill both reservoirs if necessary. Use D.O.T. 4 brake fluid.

There are bleed nipples on both circuits in order to eliminate air bubbles that could have entered the system after any work has been carried out.

The brake pedal must have some free play.

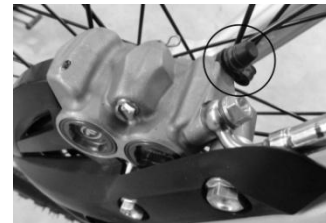

STEERING LOCK



The steering lock is located under the lower front fork triple clamp.

To lock the steering, insert the key and turn the handlebars right as far as they will go, then press and turn the key anti-clockwise.

To unlock, insert the key and turn clockwise.

SIDE STAND



The side stand is on the right of the motorcycle, secured to the chassis with a spring. Move the side stand out as far as it will go in order to rest the motorcycle on it when stationary. Never drive with the side stand unfolded.

HANDLEBAR AND INSTRUMENT PANEL



The left-hand side of the handlebar contains:

- Clutch lever.
- Horn.
- Engine stop button.
- Main/dip beam switch, and indicator switch.



The instrument panel is in the centre of the handlebar. (More information and instructions for use provided later in the manual)



The right-hand side of the handlebar contains:

- Brake lever
- Throttle

ADJUSTING LEVERS AND THE HANDLEBAR

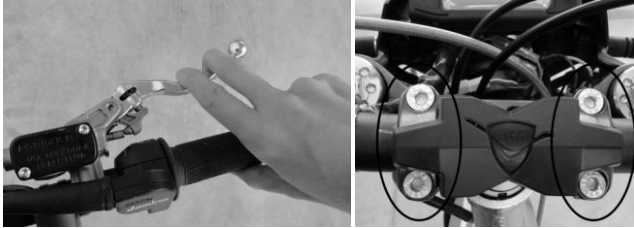

Both levers must have a **free play of 3 mm at the most**. This play must be present, do not eliminate it. To adjust, use the adjustment nuts located on the levers.

To adapt the handlebar to different types of riding, you can tilt it more or less by loosening the clamps that secure it to the fork. When adjusted as desired, tighten the bolts again, starting with the bolts closest to the seat and continuing with those closest to the speedometer.

CHECKING THE OIL LEVEL



The engine holds **400 cc** of transmission oil. Try to keep the level between maximum and minimum levels for correct operation of the engine.

Do not mix oils of different types, always top up with the same oil. We recommend 0W 75 GEAR TRANS type oil.

Oil change

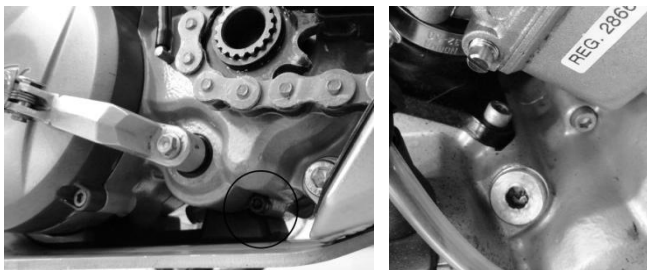

There is a plug at the bottom of the sump for emptying the oil and another plug at the top for filling. To change the oil, start up the cold engine and let it tick over for 5 minutes. This will heat the oil enough for changing.

Then place a tray under the engine and remove the oil plug. Let all the oil drain out and clean the plug removing any possible metal filings. When it is clean refit and fill with new oil through the upper filling plug orifice, until it reaches the correct level in the peep hole.

AIR FILTER



After removing the filter, it can be cleaned using a specific degreaser, then washed with water and detergent, let the filter dry and then coat it with special air filter oil. It is recommended to check the state of the air filter regularly, to avoid problems due to particles in the admission. Make sure you clean it in a ventilated place, without sparks nearby and do not use petrol for cleaning, as this could cause an explosion.

The location of hatch on the left-hand side of the motorcycle offers easy access to the air filter.

Take care with the filter foam when dismantling, as it is easily damaged.

Access the air filter through the hatch and dismantle its securing elements.

Remove the support cage with care, so as not to damage the foam.

Clean it in a container and dry with a lint-free cloth.

When it is clean, it can be slightly lubricated with special oil for air filters before replacing in its housing.

SPARK PLUG

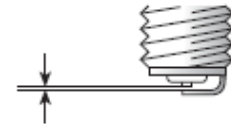

The spark plug fitted in the factory is as defined in the specifications datasheet. Tighten to 11 Nm.



For correct maintenance of the engine, it is recommended to clean the spark plug electrode with compressed air, ensuring that the gap is approximately 0.6 – 0.7 mm.

COOLING SYSTEM



Regularly check the radiator inlet and outlet tubes for impacts, cracks or leaks that could compromise the cooling. Also check the radiator alloy fins.

For correct operation of the engine, make sure the level of the coolant is correct. You can top up the radiator tank (preferably with the recommended coolant) through the cap at the top.

Do this with the engine cold and the motorcycle upright, first open the cap partially by turning anti-clockwise and let



Do not forget that the radiator can get very hot, when manipulating, take care and let it cool down after switching off the engine.

Always use coolant (-30°C) for alloy engines when topping up the radiator.

any steam escape. Then open the cap completely and top up the fluid (if necessary) until it is just below the rubber.

The coolant supplied in the factory is a permanent mix of ethylene glycol, diluted in distilled water at 50% concentration and with anticorrosion additives.

It is recommended to change the fluid after some time in use and bleed the system. Pay attention to any abnormal colour of the fluid: white particles (corroded aluminium), brown particles (corroded steel parts), and be respectful with the environment, do not pour the fluid into inadequate places.

There is a thermal switch at the bottom of the radiator; its job is to control the temperature of the liquid in the cooling circuit. This device should be in correct working order in order to avoid possible damage to the engine.

CARBURETTOR

The carburettor should be checked after a certain time, cleaning it and drying with compressed air so as to improve its performance.

Check the height of the float that maintains the level of petrol in the carburettor and adjust it so it remains at 17mm within the specified margins.

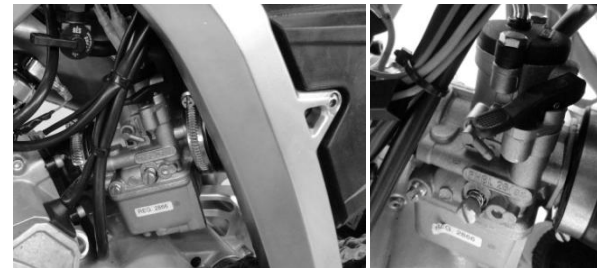

When manipulating the carburettor and adjacent parts there may be traces of fuel that must first be drained. This fuel is inflammable and toxic, take care.

Air-fuel mixture

An optimum petrol-air mixture will enable you to obtain the maximum performance from your engine. For this purpose, the amount of air and fuel entering the carburettor must be adjusted. A good way to discover the quality of the mixture is to inspect the spark plug. If the spark plug has a light brown colour, the mixture is correct; if it is black there is an excess of fuel, and if it is white there is an excess of air, in both cases the mixture entering the engine is incorrect.

To adjust the amount of petrol reaching the engine, you can modify the position of the main jet, which has a scale where the larger numbers indicate greater passage of petrol. You can also control the mixture with the air adjustment screw. Screwing in to enrich the mixture and vice-versa.

ADJUSTING THE TICK OVER



There are two screws on the carburettor that can be used to adjust the tick over: The air adjustment screw and the tick over screw, that will enable you to change the speed of operation if necessary.

REED VALVE BOX

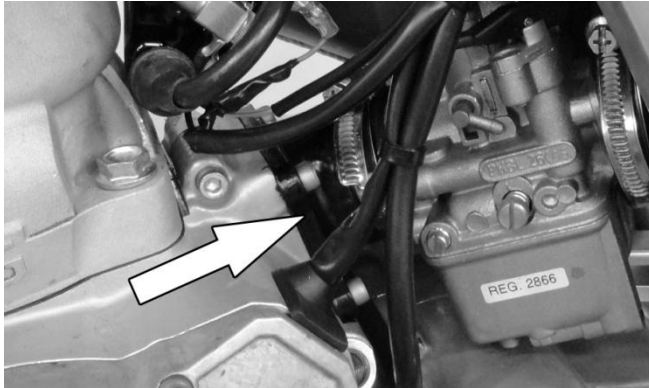

Admission is through a reed valve, the state of which has a significant influence on the performance of the engine. Whenever the carburettor is removed for cleaning, make sure the reed valves are not worn and if so, replace the box with a new one.

TRANSMISSION CHAIN



Correct tension of the chain should allow a **play of approximately 10-15 mm** in the area between the frame and the tensioner.

To tension the chain, first loosen the rear wheel axle nut and then adjust the chain using the tensioner adjustment bolts, which are in the swing arm. When adjusted, retighten the rear axle nut, paying special attention to the alignment of the chain, ensuring that it is not twisted.



Take care with this adjustment. A misaligned rear wheel axle or with the nut loose could cause an accident.

Keep the chain lubricated for optimum service life, preferably using viscous oil, for longer life.

SUSPENSION



The front fork can be adjusted with the bolts at the top of the fork. **Turning the bolt on the left-hand fork tube you can adjust the compression and if you turn the bolt on the right-hand tube you adjust the extension.** Choose the best option according to your needs, always bearing in mind that the left and right-hand cylinders must be adjusted to the same level and perfectly aligned.

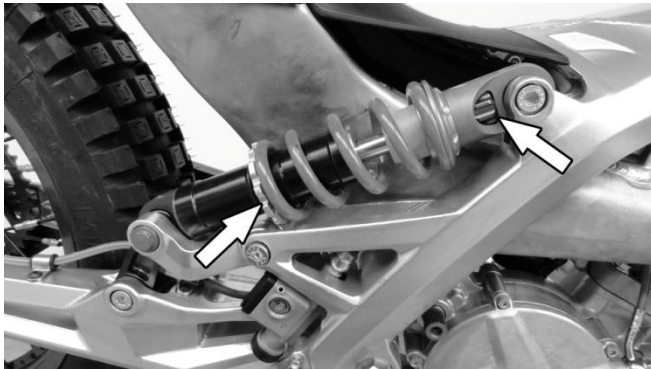

The preload of the spring can be adjusted by turning the castellated nut at the base of the shock absorber. It is also possible to adjust the hydraulic brake of the shock absorber with a bolt at the top. This bolt must be **in the middle of its travel** in normal adjustment.

SWING ARM



For correct maintenance of the rear suspension system and swing arm, it must be regularly dismantled for cleaning, checking and lubricating the internal bearings, as well as adjustment and lubrication of the chain. Make sure that all the parts are in perfect state and replace any worn components if necessary.

MAINTAINING THE MOTORCYCLE

The greater the care given to the motorcycle, the longer its service life will be and the better it will perform. Check all the elements listed below and keep them clean and lubricated for optimum service:

LEVER ARTICULATIONS

REAR BRAKE PEDAL

GEAR LEVER

FOOTRESTS AND SIDE STAND

STARTER PEDAL

THROTTLE

STEERING COLUMN

TRANSMISSION CHAIN AND SWING ARM ARTICULATIONS

CHAIN TENSIONER

SPEEDOMETER

These are the most important features of the control panel and speedometer fitted to your motorcycle:

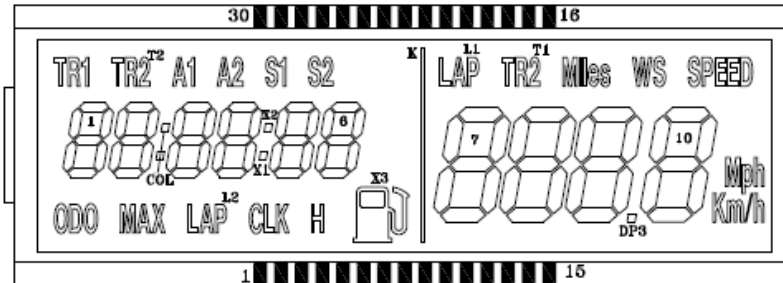

These are its features:

Max. speed	Overestimation	Resolution	Updated	Impulses/revolution
300 Km/h (186 Mph)	4% constant	1 Km/h (1 Mph)	Every 500ms	1

The basic functions (Always visible and cannot be deselected from the setup menu) of the panel are:

- Current speed (SPEED)
- Total distance covered (ODO)
- Total time of vehicle operation (H)

SPEED function

This information is always visible, regardless of the status of the vehicle (stationary or in movement). The default configuration indicates Km/h.

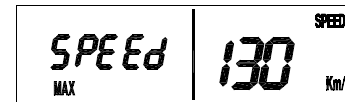
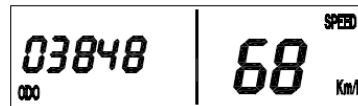

If the speed of the vehicle exceeds 110 km/h for more than 20 consecutive seconds, the status on the right-hand illustration will be displayed flashing. This signal will continue until the speed of the vehicle drops below 110 km/h for at least 10 consecutive seconds.

ODO function

This information can only be seen by pushing the MODE button, regardless of whether the vehicle is stationary or in movement. The predetermined configuration indicates Km and each Km is permanently stored in the in the memory.

H function

This function indicates the hours the vehicle has been in operation and can be seen by pressing the MODE, button, regardless of whether the vehicle is stationary or in movement. The counter associated with this function only works when the vehicle is in movement, on receiving the first impulse from the speed sensor, and it stops 3s after receiving the last impulse from the sensor.

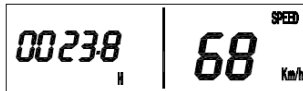

Clock function (CLK)

This function indicates the current time in "hh:mm:ss" format. The clock remains active even when Sleep Mode is activated.

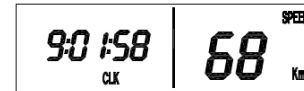

The time can only be set when the vehicle is stationary, pressing the MODE button several times until the display screen is as illustrated above. When the CLK mode is displayed, pressing the MODE button for a few seconds, the active digits will begin to flash (In this order: hours, minutes, seconds and in display mode), which can be modified with the UP and DOWN buttons, and select with the MODE button. In time configuration mode, if 20 seconds pass without pressing any button or if the vehicle begins to move, the system will return to standard operational mode, saving the modified configuration.

Trip, Average speed and Automatic Chronometer functions (TR1, A1 and S1)

These functions indicate the partial distance covered, average time and the time the vehicle has been on the current trip. They are activated automatically and are displayed on the screen with the indicators TR1, A1 and S1 respectively, displaying the distance covered in km, speed in km/h and time in hours, minutes and seconds by default.

Manual Stopwatch function(LAP)

This function enables you to activate or deactivate a stopwatch manually, either if the vehicle is stationary or in movement. To activate the stopwatch, press the UP button on the screen displayed below, and to deactivate, press the UP button again. To delete the average time, press the DOWN button.

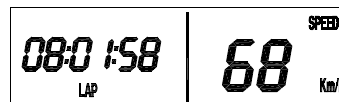

For more information on the rest of functions of the system, go to:

<http://www.jotagas.com>

TORQUE VALUES

ELEMENTS FASTENED	Nm
Swinging arm-Chassis	40-50
Upper shock absorber fastener	40-50
Lower shock absorber fastener	40-50
Front wheel axle	40-50
Connecting rods	40-50
Handlebar	25-30
Front mudguard bridge	7-10
Silencer	10-15
Rear wheel axle	40-50
Front brake caliper fasteners	25-30
Exhaust pipe fasteners	10-15
Engine fasteners	30-35
Rear brake master cylinder fasteners	7-10
Spark plug	11
Ignition fasteners	7-8
Clutch fasteners	20-25

Cylinder stud fasteners	25
Reed valve fasteners	7-8
Clutch spring fasteners	3-4
Sump fasteners	7-8
Water pump cover fastener	7-8
Clutch cover fasteners	7-8
Flywheel fasteners	40
Ignition cover	7-8
Sump drain plug	12
Starter pedal bolt	12-13
Gear change pedal bolt	7-8
Cylinder head nuts	12-13

STORAGE

If it is necessary to store the motorcycle for a long period of time, the following operations are recommended before storage:

- Clean the whole vehicle.
- Lubricate or grease the components that need it.
- Empty the fuel tank. (Take care with the fuel, which is inflammable and toxic)
- Empty the sump, removing the old transmission oil and refilling with new oil (If the engine is cold, it is recommended to start up and leave running for a few minutes to warm up the oil and favour draining).
- Cover the exhaust with a plastic bag, protecting it from the elements.
- Any unpainted metal parts that could get rusty should be coated with oil.
- Avoid the tyres touching the ground by placing a piece of cardboard or similar material under them.
- Protect the motorcycle as much as possible from dust and dirt by covering it with a plastic or canvas sheet.

When putting the motorcycle back into service, first:

- Remove the plastic protection used.
- Check the oil and lubrication of components.
- Check the spark plug.
- Adjust tyre pressure to the recommended value.
- Fill the petrol tank.

MAINTENANCE OPERATIONS

(NOTE: Bear in mind that a clean motorcycle will facilitate inspection and detection of faults and wear)

COMPONENT	CHECK	ADJUST	REPLACE	CLEAN	LUBRICATE
Rear shock absorber	Annually		Every 2 years		
Front fork suspension oil			60h		
Transmission oil	30h		60h		
Brake adjustment	Every time it is used	Whenever necessary			
Spark plug		30h	60h	15h	
Swinging arm and connecting rods	Every time it is used		If damaged	Every time it is used	Whenever it is cleaned
Transmission chain	Every time it is used	Whenever necessary	If damaged	Every time it is used	Whenever it is cleaned
Throttle cable and twist grip	Every time it is used	Whenever necessary	If damaged	Whenever necessary	Whenever it is cleaned
Reed valve box	30h		If damaged	Every time it is used	
Carburettor		Whenever necessary	If damaged	Every time it is used	
Chassis			If damaged	Every time it is used	

Carburettor jet		Whenever necessary	If damaged		
Steering bearing			If damaged		
Piston bearing			If damaged		
Wheel bearing			If damaged		
Engine bearings			If damaged		
Rear sprocket	30h	First 5h	If damaged		Every time it is cleaned
Cylinder head and cylinder	60h		Annually		
Brakes	Every time used	Whenever necessary	If damaged		
Brake discs	Every time used	First 5h	If damaged	Every two uses	
Clutch plates			If damaged		
Clutch			If damaged		
Wheel-silencer clearance	Every time used		In case of a fall		
Escape			500h		
Silencer fibre			100h		
Air filter	Every time used		If damaged	Every time used	Every time it is cleaned
Steering play	Every time used	Whenever necessary			
Brake hoses		Whenever necessary	Every 2 years		Every time it is cleaned

Coolant		Whenever necessary	Annually		
General lubrication	Every time used			Every time used	Every time it is cleaned
Front and rear wheel			If damaged	Every time used	
Tyres	Every time used		If damaged	Every time used	
Brake fluid level		Whenever necessary			
Chain guide slipper			If damaged		
Starter pedal and gear change pedal			If damaged		Every time it is cleaned
Brake master cylinder piston and dust cover			If damaged		
Brake piston and dust cover			If damaged		
Piston and rings	60h		Annually		
Front and rear wheels		5h	If damaged	Every time used	
Fuel system	Every time used		If damaged		
Front suspension		Whenever necessary	If damaged		
Exhaust seal			If damaged		
Nuts, bolts and other fasteners		Whenever	If damaged		

		necessary			
Petrol tube	Every time used	Whenever necessary	If damaged		
Radiator tube and joints	Every time used	Whenever necessary	If damaged		
Chassis protective adhesive elements			If damaged		
Sump protector			If damaged		

HOMOLOGATION

All the components fitted in this vehicle comply with legal homologation requirements, including the identification marks on part that require them.

Pay attention to the component that are compulsory for using the motorcycle on public roads and must be present on the vehicle in order to pass the Vehicle Technical Inspection Test:

- Registration plate holder
- Speedometer
- Lighting system and reflectors
- Indicators
- Horn
- Rear view mirrors
- Steering lock
- Manufacturer's identification plate
- Air filter restrictor
- Exhaust system with catalyser
- Silencer
- Carburettor jets
- Side stand

IMPORTANT NOTE: The vehicle is also supplied with a RACING KIT containing additional components. Bear in mind that the modifications provided by this kit are NOT covered by the vehicle homologation.

TROUBLESHOOTING

(**IMPORTANT NOTE:** For all internal adjustments or replacement of parts that are not normal wearing components it is recommended to take the motorcycle to an authorised workshop. Bear in mind that unskilled manipulation of the motorcycle can be dangerous for you and/or possibly render the guarantee void.)

PROBLEM	POSSIBLE CAUSES	ACTIONS
The engine will not start	<ul style="list-style-type: none"> - Dirty spark plug. - Engine flooded. - Fuel badly mixed. - 	<ul style="list-style-type: none"> - Clean and dry the spark plug or change it. - Open the throttle fully and kick the starter pedal 5 to 10 times and then start the engine. - Check for obstruction in the petrol tank tubes and air filter.
The motorcycle starts well and then stops	<ul style="list-style-type: none"> - Incorrect air supply, engine flooded. - Insufficient petrol. 	<ul style="list-style-type: none"> - Close the choke, check the fuel pipes. - Fill the fuel tank.
Engine excessively hot	<ul style="list-style-type: none"> - Low level of coolant. - Radiator dirty or obstructed. 	<ul style="list-style-type: none"> - Add coolant, check for possible leaks. - Clean the radiator fins.
Engine runs erratically	<ul style="list-style-type: none"> - Problems with the spark plug and/or plug cap. - Fault in the ignition rotor. - Water in the fuel. 	<ul style="list-style-type: none"> - Check the state of both. - Change the rotor. - Empty the tank and refill with new petrol.

Engine makes strange noises	<ul style="list-style-type: none"> - Ignition problems. - Overheated engine. 	<ul style="list-style-type: none"> - Take motorcycle to an authorised workshop. - Stop the engine and check the state of the cooling and exhaust systems.
Engine lacks power	<ul style="list-style-type: none"> - Admission problems. - Exhaust system problems. - Carburettor jets dirty. - Damaged crankshaft bearings. - Clutch slipping. 	<ul style="list-style-type: none"> - Clean the fuel admission system and air filter. - Check for leaks in the system and clean or replace the silencer fibre. - Remove the carburettor and clean them. - Replace the bearings. - Check its adjustments. Take bike to a specialised workshop.
Exhaust gives off white smoke	<ul style="list-style-type: none"> - Water in the cylinder. - Accelerator cable incorrectly adjusted. 	<ul style="list-style-type: none"> - Change the cylinder head O-ring. - Check accelerator adjustment.
Exhaust gives off brown smoke	<ul style="list-style-type: none"> - Lack of air in the mixture. - Main jet too high. 	<ul style="list-style-type: none"> - Clean or change the air filter. - Check the main jet.
Explosions in the exhaust	<ul style="list-style-type: none"> - Carbon deposits in the combustion chamber. - Incorrect type of fuel. - Spark plug in bad condition or wrong type. - Exhaust system gaskets damaged. 	<ul style="list-style-type: none"> - Clean the combustion chamber. - Empty fuel tank and refill with correct type of fuel. - Replace spark plug with correct type. - Check state of gaskets and replace if necessary .
Clutch not working correctly	<ul style="list-style-type: none"> - No play in the clutch lever. - Clutch worn. 	<ul style="list-style-type: none"> - Take bike to a specialised workshop.

	<ul style="list-style-type: none"> - Clutch springs broken or weak. 	<ul style="list-style-type: none"> - Take bike to a specialised workshop. - Take bike to a specialised workshop.
Gears engage badly	<ul style="list-style-type: none"> - Problems in forks, gears or additional gearbox systems. 	<ul style="list-style-type: none"> - Take bike to a specialised workshop.
Abnormal noises	<ul style="list-style-type: none"> - Worn or badly adjusted chain - Rear sprocket teeth worn. - Chain needs lubrication. - Badly aligned rear wheel. - Lack of oil in the front fork. - Problems with the front fork springs. - Worn brake disc. - Brake pads glazed or badly fitted. 	<ul style="list-style-type: none"> - Adjust or change chain. - Change rear sprocket. - Apply appropriate chain lubricant. - Take bike to a specialised workshop. - Add fork oil to the specified level. - Replace front fork spring. - Replace brake disc. - Refit pads or replace.
Unstable ride	<ul style="list-style-type: none"> - Steering shaft nut too tight. - Steering bearings worn or damaged. - Bent steering shaft. 	<ul style="list-style-type: none"> - Loosen the steering nut a little. - Replace bearings. - Take bike to a specialised workshop.
Suspension too hard	<ul style="list-style-type: none"> - Too much oil in fork. - Oil in fork too dense. - Twisted or bent fork. - Excessive tyre pressure. - Rear shock absorber badly adjusted. 	<ul style="list-style-type: none"> - Remove excess oil. - Replace oil with correct density. - Take bike to a specialised workshop. - Adjust tyre pressure. - Adjust rear shock absorber.
Suspension too soft	<ul style="list-style-type: none"> - Low oil level in fork. - Oil with excessively low density. 	<ul style="list-style-type: none"> - Add the right oil to the specified level. - Replace oil with correct density. - Adjust rear shock absorber.

	<ul style="list-style-type: none"> - Rear shock absorber badly adjusted. 	
Handlebar vibration	<ul style="list-style-type: none"> - Worn tyre, swinging arm or bearings worn. - Rim out of true. - Badly aligned wheel. - Steering shafts, handlebar supports or fasteners with play. 	<ul style="list-style-type: none"> - Take bike to a specialised workshop. - Take bike to a specialised workshop. - Take bike to a specialised workshop. - Tighten nuts and fasteners to specified torque.
Brakes working badly	<ul style="list-style-type: none"> - Pads worn - Discs worn. - Loss of brake fluid. - Brake fluid in bad state. - Master cylinder piston worn. - System badly adjusted. 	<ul style="list-style-type: none"> - Change pads - Change discs. - Check circuits. Replace leaking parts and top up fluid to the correct level. - Remove brake fluid circuit and replace with fresh fluid of the right type. - Replace master cylinder piston. - Adjust brakes.
Fusing bulbs	<ul style="list-style-type: none"> - Voltage regulator problems. 	<ul style="list-style-type: none"> - Check connections. Check voltage regulator and fuses.