

www.opti-ups.com

Placement

This UPS is intended for indoor use only; its internal components are not sealed from the environment. Please install it in a protected environment away from excessive heat or excessive moisture.



Charging the UPS first

The battery is fully charged at the factory. However, it is recommended to charge the battery at least 8 (eight) hours before using the UPS, since energy loss may have occurred during shipping or long duration storage. To recharge the battery, simply leave the UPS plugged into an AC outlet.

Connecting your equipment to the UPS

For UPS models with US-type outlets: connect the power cord(s) of your computer equipment to the output receptacle(s) of the UPS.

For UPS with IEC outlets, as shown in the illustration, use your computer power cord to connect UPS to the wall socket. Use the power cord supplied with the UPS to connect your PC to one of UPS outlets (item 1.5 on the rear panel drawing below).

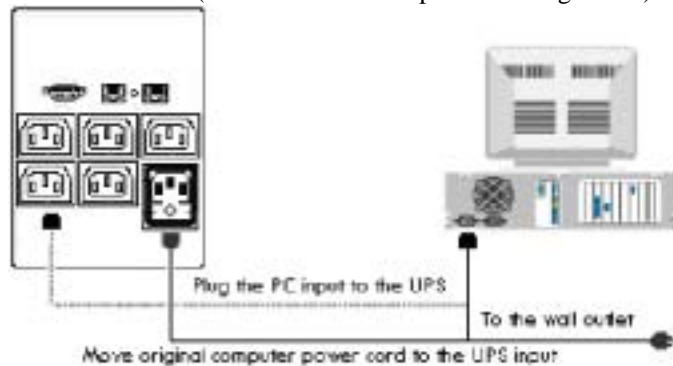

Turn on the UPS

To turn UPS on please press the power button for 3 seconds. Pressing the power button shortly under normal mode will enable the self-test function. The silence function can be enabled/disabled by shortly pressing the power button in backup mode. In addition, the power button can be used as the master on/off switch for your equipment by leaving your equipment connected to UPS and switched on. To turn off the UPS, please press power button for about 3 seconds.

Front & Rear Panels

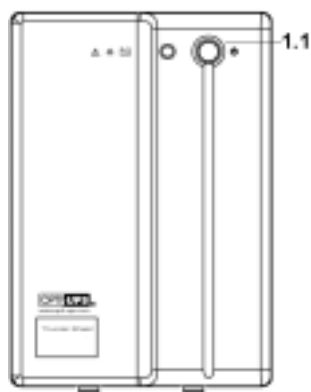

- 1.1 Power Button
- 1.2 RS-232 Port^{*)}
- 1.3 Phone/LAN Jack^{*)}
- 1.4 AC Input
- 1.5 UPS Outlets
- 1.6 Surge Suppression Outlet^{**)}
- 1.7 Circuit Breaker
- 1.8 AC Fuse

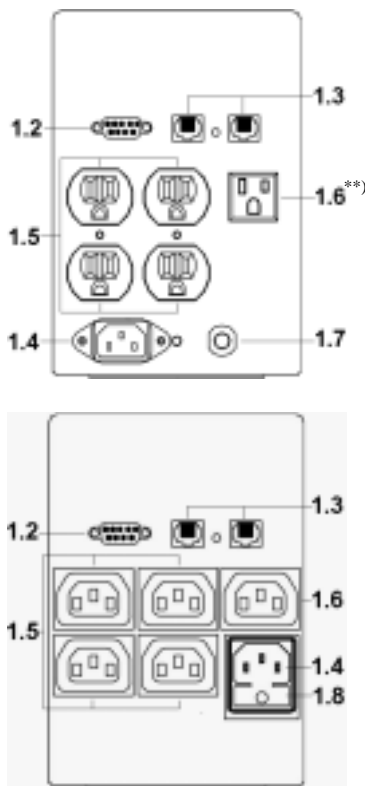

^{*)} TS-B models only
^{**)} Battery Backup Outlet for TS1700(B) (110V/120V) / TS2250(B) (110V/120V/220V/230V/240V)

No Load Shutdown Function

As a battery saving feature, the UPS will automatically turn off if none of the connected equipment is operating while the UPS is in back-up mode. Once normal utility power returns, the unit will re-start automatically. You can disable the "No Load Shutdown" function by pressing the power button of your switched-off UPS until you hear two beeps.

Front panel LED (UPS status indicator)

 AC Mode	When the LED is continuously lit and the buzzer is silent, the UPS is in normal mode and providing power to your equipment. The UPS will continue to filter electrical noise and provide surge protection.
 Battery Mode	When the LED blinks every 2 seconds in time with the beeping sound, the UPS is providing power from its battery.
 Fault	When the LED is flashing rapidly and the beeping sound is continuous, it indicates that the UPS is overloaded.

Warning

DO NOT PLUG LASER PRINTERS INTO THE UPS BECAUSE THEY TYPICALLY DRAW TOO MUCH POWER

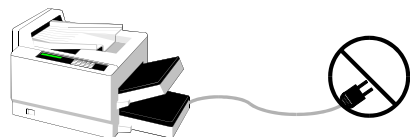

Fuse replacement procedure

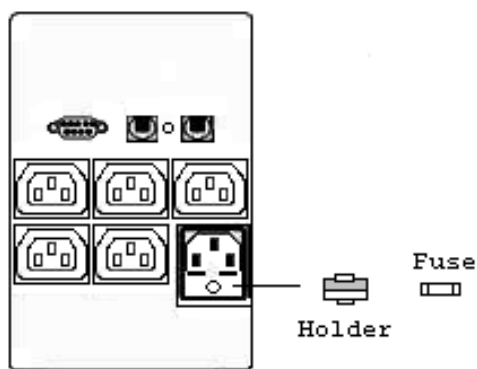

- (Note: for 220V/230V/240V units only)
1. Use a slotted screwdriver to take out the fuse holder
 2. Take out the busted fuse from the fuse holder
 3. Use the screwdriver to push out the spare fuse from the holder
 4. Put the spare fuse in the holder
 5. Push the fuse holder back into the AC input socket
 6. Follow the UPS turn on procedure

Battery replacement procedure

Note: Follow this procedure for safe replacement of the battery. However, small sparks may occur during the process. This is normal.

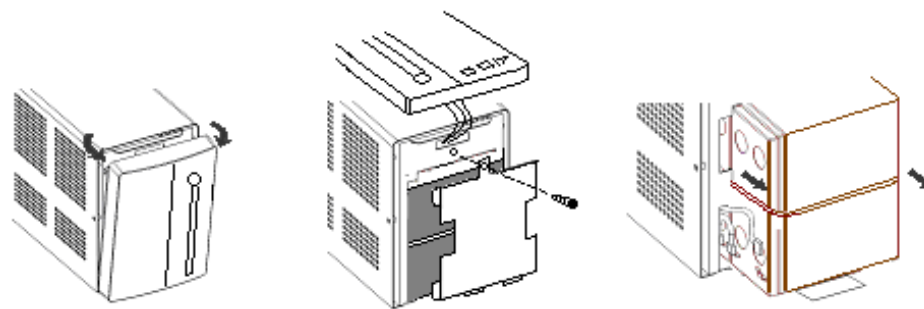

1. Turn off the UPS and unplug it from the wall outlet
2. Remove two screws both sides nearby the front panel
3. Gently pull the top portion of the front panel until it unsnaps
4. Place the front panel on top of the unit taking care not to pull out the wires for the panel
5. Remove the screw for the battery cover
6. Gently pull out the batteries using the tab located at the base of the battery
7. Disconnect the two long wires connecting the batteries to the UPS
8. Use the short wire to connect between the batteries and push the new batteries into place
9. Connect the long wires to the new batteries, making sure that the red wire is connected to the red battery terminal of the lower battery and the black wire to the black battery terminal of the upper battery
10. Mount the battery cover and replace the screw
11. Snap back the front panel into place
12. Follow the UPS turn on procedure

Specifications

Model	Thunder Shield 1250(B)	Thunder Shield 1700(B)	Thunder Shield 2250(B)
Maximum Capacity	600W	900W	1200W
Topology	Line-interactive		
On-battery Output Waveform	Simulated Sine Wave		
Input Voltage Range	110/120V or 220/230/240V +/- 25%		
Input Frequency	50Hz/60Hz Auto Sensing		
Output Voltage Regulation	Rated voltage +/- 5%		
Communication Port	RS232 ^{*)}		
Data Line Surge Protection	RJ11/RJ45 ^{*)}		
Surge Energy Rating	480 Joules		
Recharge Time to 90%	6 hours		
Operating Temperature	0~40°C / 32~104		
Storage Temperature	-20~60°C / -4~140		
Relative Humidity	0 to 95% maximum, non-condensing		
Audible Noise	<40 dBA		
Unit Dimensions (LxWxH), mm	382x130x192		
Net Weight, kg	13.4 (14.8)	15.9 (17.3)	
EMC/RFI Compatibility	CE		
Safety Certifications	CE, UL, cUL		

^{*)} TS-B models only

Warranty

LIMITED WARRANTY

What the warranty covers:

We guarantee this product to be free from defects in material and workmanship during the warranty period. If a product proves to be defective in material or workmanship during the warranty period, we will at our sole option, repair or replace the product with a like product.

How long the warranty is effective:

For accurate warranty period and conditions, please contact the local branch offices or your dealers.

Who the warranty protects:

This warranty is valid only for the first consumer purchaser.

What the warranty does not cover:

- Any product on which the serial number has been defaced, modified or removed.
- Damage, deterioration or malfunction resulting from:
 - Accident, misuse, neglect, fire, water, or other acts of nature, unauthorized product modification, or failure to follow instructions supplied with the product.
 - Repair or attempted repair by anyone not authorized by OPTI-UPS.
 - The fault is the result of accidental damage or damage in transit or transportation, including but not limited to liquid spillage.
 - Removal or installation of the product.
 - Causes external to the product.
 - Use of supplies or parts not meeting our specifications.
 - Normal wear and tear.
 - Any other cause which does not relate to a product defect.
- Removal, installation and set-up service charges.

Limitation of implied warranties:

There are no warranties, expressed or implied, which extend beyond the description contained herein including the implied warranty of merchantability and fitness for a particular purpose.

Exclusion of damages:

Our liability is limited to the cost of repair or replacement of the product. We shall not be liable for:

- Damage to other property caused by any defects in the product, damages based upon inconvenience, loss of use of the product, loss of time, loss of profits, loss of business opportunity, loss of goodwill, loss of data, loss of software, costs of substitute equipment, interference with business relationships, claims by third parties, or other commercial loss, even if advised of the possibility of such damages.
- Any other damages, whether incidental, consequential or otherwise.
- Any claim against the customer by any other party.

Troubleshooting

Problems	Possible Cause	Solution
UPS can't turn on, LED does not light	Power switch not pressed long enough	Press the power switch for more than 1 second until the UPS turns on
	Battery voltage is less than 10V	Recharge the battery for 6 hours by leaving the UPS plugged in and the load disconnected from the UPS.
	Load is less than 20W at battery mode	Disable "No Load Shutdown Function"
	PCB failure	Call for service
UPS always at battery mode	Input power cord is loose	Plug in the power cord firmly
	Busted input fuse	Replace the fuse
	Input voltage too high or too low	Check input voltage
	PCB failure	Call for service
Back up time too short	Battery is not fully charged or defective	Recharge the battery for 6 hours. If the problem is still present, replace the battery.
	PCB failure	Call for service
Buzzer continuously beeping	Overload	Remove some loads

Contact Information

OPTI-UPS USA:
Tel: +1-909-869-5700
Fax: +1-909-869-5730
Toll Free: (888) OPTI-UPS
info@opti-ups.com
http://www.opti-ups.com

OPTI-UPS Australia:
Tel: +61-3-9545-5322
Fax: +61-3-9545-5669
Toll Free AU: 1800-678-428
info@optiups.com.au
http://www.optiups.com.au

OPTI-UPS UK:
Tel: +44 0208 622 3083
Fax: +44 0208 622 3200
info@opti-ups.co.uk
http://www.opti-ups.co.uk

OPTI-UPS Middle East:
Tel: +9714-8819-838
Fax: +9714-8819-938
inquiry@opti-ups.com
http://www.opti-ups.com

OPTI-UPS Europe:
Tel: +49-89-3715-6420
Fax: +49-89-37156-4229
info@opti-ups.de
http://www.opti-ups.de

OPTI-UPS Panama:
Tel: +507-4415668
Fax: +507-4416851
tony@opti-ups.com
http://www.opti-ups.com

OPTI-UPS Czech:
Tel: +420-604-444077
Fax: +420-604-444077
info@opti-ups.cz
http://www.opti-ups.cz

OPTI-UPS Asia:
Tel: +886-2-2246-7272
Fax: +886-2-2246-7312
Toll Free: 0800-029898
info@opti-ups.com.tw
http://www.opti-ups.com.tw