



LaserSense 100 Aspirating Smoke Detection System Installers Handbook

Copyright © 2012 UTC Fire and Security. All rights reserved.

Manufacturer Kidde Products Limited
Unit 2 Blair Way Dawdon
City: Seaham, County Durham
SR7 7PP
United Kingdom

Certification  0832
0832-CPD-0982
EN54-20: 2006
Aspirating smoke detectors for fire detection and fire alarm systems
for buildings.
Class A, B and C
Technical data: See INF48029 held by the manufacturer

Contact information For contact information, see www.utcfireandsecurity.com.

Content

	Important information	2
	EN 54-20	4
Chapter 1	Product and component descriptions	1
	Introduction	2
	Available software for the detector	2
	Specifications	3
	Indicators	4
	Inside the detector	5
	Removable terminal block connections	6
Chapter 2	Installation and configuration	7
	Introduction	8
	Antistatic precautions	8
	General installation guidelines	9
	Docking station	9
	Application	10
	System design	11
	Mechanical installation	16
	Relay connections	20
	Interfacing with fire alarm panels	20
	Setting the detector address	22
	Connecting the detector to a SenseNET/RS-485 detector network	25
	Final installation	27
	Removing the detector	27
	Configuring the detector after installation	27
	Connecting to a PC	29
	Event log	31
Chapter 3	Commissioning	33
	Introduction	34
	Precommissioning preparation	34
	Commissioning checklist	34
Chapter 4	Troubleshooting	37
	Troubleshooting the detector	38
Chapter 5	Maintenance	41
	Introduction	42
	Diagnostics	43
	Index	45

Important information

Regulatory information

This equipment is Class III as defined in EN 60950 (i.e., this equipment is designed to operate from Safety Extra Low Voltages and does not generate any hazardous voltages).

As this equipment is part of a fire detection system, input power should be supplied from an approved power supply conforming to EN 54-4.

In order for the installation to conform to EN 54-20, pipes must conform at least to EN 61386-1 Class 1131.

Limitation of liability

To the maximum extent permitted by applicable law, in no event will UTCFS be liable for any lost profits or business opportunities, loss of use, business interruption, loss of data, or any other indirect, special, incidental, or consequential damages under any theory of liability, whether based in contract, tort, negligence, product liability, or otherwise. Because some jurisdictions do not allow the exclusion or limitation of liability for consequential or incidental damages the preceding limitation may not apply to you. In any event the total liability of UTCFS shall not exceed the purchase price of the product. The foregoing limitation will apply to the maximum extent permitted by applicable law, regardless of whether UTCFS has been advised of the possibility of such damages and regardless of whether any remedy fails of its essential purpose.

Installation in accordance with this manual, applicable codes, and the instructions of the authority having jurisdiction is mandatory.

While every precaution has been taken during the preparation of this manual to ensure the accuracy of its contents, UTCFS assumes no responsibility for errors or omissions.

Advisory messages

Advisory messages alert you to conditions or practices that can cause unwanted results. The advisory messages used in this document are shown and described below.

WARNING: Warning messages advise you of hazards that could result in injury or loss of life. They tell you which actions to take or to avoid in order to prevent the injury or loss of life.

Caution: Caution messages advise you of possible equipment damage. They tell you which actions to take or to avoid in order to prevent the damage.

Note: Note messages advise you of the possible loss of time or effort. They describe how to avoid the loss. Notes are also used to point out important information that you should read.

Product Symbols



This symbol appears on the main board of the unit and indicates that the board contains static sensitive components.



This label is located on the laser chamber at the bottom right of the open detector and signifies that the unit is a Class 1 Laser product as specified in IEC 60825-1. The unit incorporates a Class 3B embedded laser which must not be removed from the detector, as retinal damage may result if the laser beam enters the eye.



This symbol indicates the Safety ground studs. These are for grounding cable screens, etc., and should not be connected to 0V or signal earth.

EN 54-20

The installation must be designed using PipeCAD software, which is provided free on the CD shipped with each detector. After designing the installation including pipes, endcaps, and sampling holes, enter the detector type. To select the detector type, select Options, select Calculation options, and then select the detector from the Type drop-down list.

Select "Options" "Calculate" or click on the calculator icon. The software will prompt you to choose from "Use set hole sizes" "Best flow balance" and "Max. permissible transit time." Select the appropriate option and click "OK". The results for each pipe ("View" "Results") show calculations for each sampling hole on the pipe with the nearest to the detector at the top of the screen, and the endcap hole at the bottom.

For EN 54-20 compliance the transport time of the last sampling hole shall be checked following all installation and proven to be less than or equal to that determined by PipeCAD.

The classification of each sampling device configuration and associated sensitivity settings are determined by the column headed "Hole sensitivity % obs/m" which shows the predicted sensitivity for each hole. For the installation to comply with EN 54-20 depending on the class of installation, each sampling hole must be no less sensitive than the following:

Class A: 0.62% obs/m

Class B: 0.62% obs/m

Class C: 0.62% obs/m

The calculation can be further refined by leaving a working detector in the protected area for at least 24 hours at the intended alarm factor for the installation (this could be done before or after installation). The detector sensitivity can be read from the "Sensitivity" figure on the histogram screen of the Remote software supplied with each detector. Click "Options" and then click "Calculation options" to open the "Hole calculation options" dialog box. Enter the sensitivity value obtained from the practical test, and then click OK. The new calculated value will use the real sensitivity from the practical test.

The PipeCAD software will determine the classification of any used configuration. Commissioning and periodic system tests must involve smoke tests to verify that the system performs as expected and enters Fire 1 alarm within the time determined by PipeCAD from the farthest hole. The detector sensitivity must also be inspected to ensure it has not radically fallen from the installed figure. If it has changed for any reason, the new figure must be re-entered into PipeCAD and the recalculated hole sensitivities must be confirmed to be within the class limits shown above. The settings of a compliant system should be recorded, as it is possible by changing certain programmable functions to make the system noncompliant. If functions are changed, it is recommended that the system is retested if continuing compliance is in any doubt.

Chapter 1

Product and component descriptions

Summary

This chapter provides descriptions of the detector features, specifications, and controls and indicators.

Content

Introduction	2
Available software for the detector	2
Specifications	3
Indicators	4
Inside the detector	5
Removable terminal block connections	6

Introduction

This detector is a highly sophisticated “next generation” high sensitivity aspirating smoke detection product that provides all the benefits of air sampling high sensitivity smoke detection, including very early warning. Designed for easy installation and commissioning, the detector incorporates a patented “artificial intelligence” known as ClassiFire, which allows the detector to configure itself to optimum sensitivity, alarm thresholds, and minimum nuisance alarms for various environments.

The detector operates by drawing air from a protected space via a supervised piping network in relatively small areas. The sampled air is passed through a “dust separator” to remove dust and dirt before entering the laser detection chamber. State of the art electronics are used to analyse the sampled air and generate a signal representing the level of smoke present.

ClassiFire intelligence also monitors the detector chamber and dust separator (filter) for contamination, continually adjusting the appropriate operating parameters to counteract the negative effects of any contamination. Aspirating smoke detectors are unique in being able to provide a consistent level of protection in a very wide range of environments by continuously making minor adjustments to sensitivity.

The aspirating line of detectors detects “difficult-to-detect” slow growth electrical overload incipient fires in “difficult” environments.

Available software for the detector

The Remote Configuration and the SenseNET software packages are available for use with the detector.

- **Remote Configuration software:** Provided free of charge with every detector, this software package enables the user to set up and configure the programmable functions of one or more detectors or Command Module from a computer connected via an RS-232 serial cable.
- **SenseNET software:** SenseNET software is used to configure and manage a large network of detectors with a simple, streamlined graphical user interface from a computer connected to a detector or Command Module via an RS-232 serial cable to RS-485 converter interface.

Specifications

Caution: This equipment is only to be used in accordance with this specification. Failure to operate the equipment as specified may cause damage to the unit, injury, or property damage.

Table 1: Specifications

Specification	Value
SELV rating (EN 60950)	Class III
Supply Voltage	21.6V to 26.4VDC PSU Type: conforming to EN 54-4 Electrical safety complies with BS EN 610190-1
Size	300 W x 220 H x 90 D (mm) 11.8 W x 8.6 H x 3.5 D (in.)
Weight	3.8 kg (8.4 lbs.) with docking station
Operating temperature range	-10 to +60°C (EN54-20)
Operating humidity range	0 to 90% noncondensing BS EN 61010-1 Pollution degree 1 BS EN 61010-1 Installation Cat. II
Sensitivity range (%obs/ft.) (%obs/m)	Min. = 7.62%, Max. = 0.00914% FSD Min. = 25%, Max. = 0.03% FSD
Maximum sensitivity resolution	0.0015% obs/m (0.00046% obs/ft.)
Detection principle	Laser light scattering mass detection
Particle sensitivity range	0.0003 µm to 10 µm
Current consumption	400 mA
Relay contact rating	500 mA at 30 VDC
Maximum sampling pipe length	100 meters (330 feet) total
Sampling pipe inlets	2
Sampling pipe internal diameter	3/4 in. (ID) or 27 mm (OD)
Alarm levels	4 (Fire 2, Fire 1, Pre-Alarm and Aux) 1 relay as standard, others available
Chamber service intervals	Greater than 8 years (depending on environment)
Dust separator (filter) replacement intervals	Greater than 5 years (depending on environment)
Laser lifetime (MTTF)	Greater than 1,000 years
Programming	PC via RS-232 or RS-485
Data bus cable	RS-485 data cable
Data bus length	1.2 km (3/4 mile)
IP rating	IP50

Indicators

Figure 1 below shows the three indicators on the detector.

Figure 1: Detector indicators

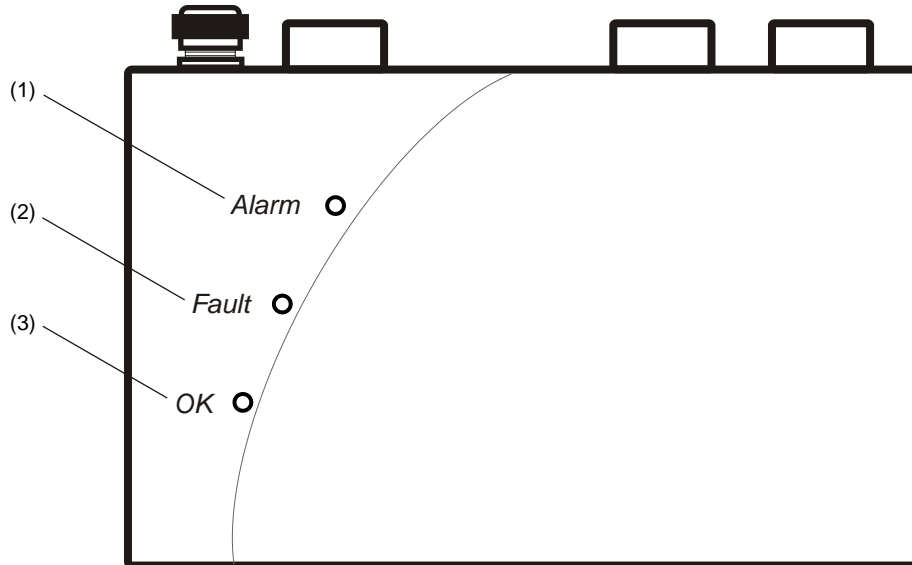

- (1) Alarm: Illuminates when the alarm level has been reached and the appropriate time delays have expired.
- (2) Fault: Illuminates when the unit has a fault and a fault signal is being sent to the fire alarm panel.
- (3) OK: Illuminates to show normal operation when there are no faults. The OK lamp will flash during the 15-minute FastLearn period when the detector is first learning about its environment.

Inside the detector

Figure 2 below shows the main interior parts of a detector with the cover off:

Figure 2: Detector interior view

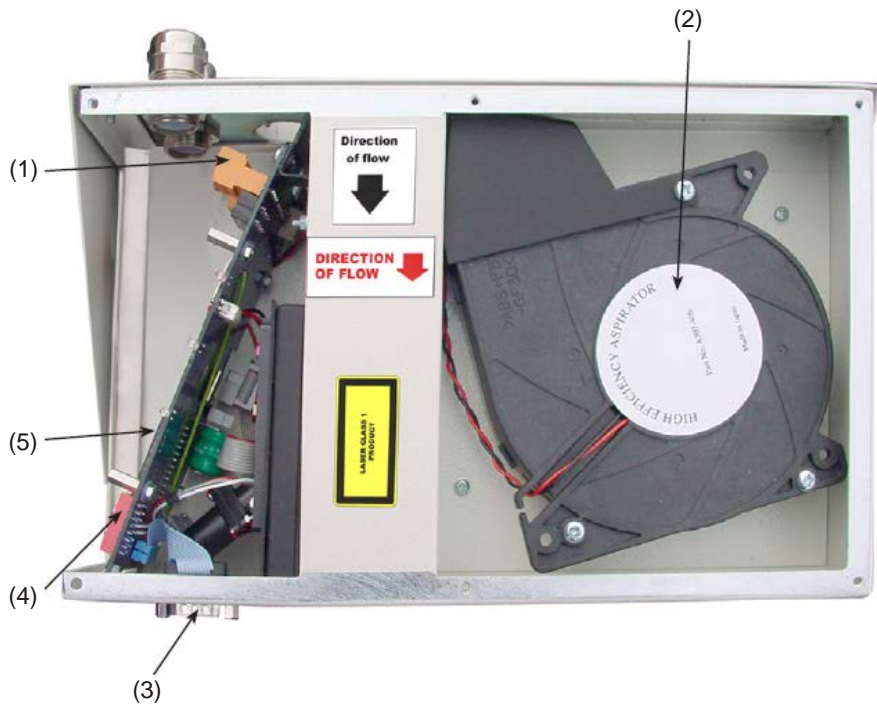

- (1) Removable terminal block connections
- (2) Filter
- (3) RS232 serial port
- (4) Detector address DIP switch
- (5) Addressable Programmable Interface Card (APIC) or relay card port

Removable terminal block connections

Figure 3 below shows the terminal block connections that connect the detector to other electronic components.

Figure 3: Detector terminal block connections

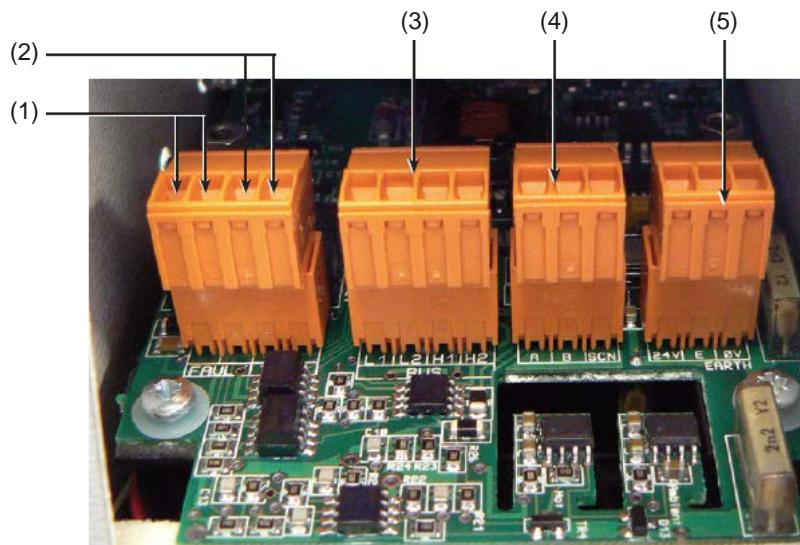

- (1) FAULT relay contacts (Open = FAULT)
- (2) FIRE relay contacts (Closed = ALARM)
- (3) APIC addressable bus connections for use in conjunction with interface card
- (4) RS-485/SenseNET connections
- (5) Power supply connections

Chapter 2

Installation and configuration

Summary

This chapter provides information necessary to install and configure the detector system.

Content

Introduction	8
Antistatic precautions	8
General installation guidelines	9
Docking station	9
Application	10
System design	11
Below or above the ceiling installations	13
Mechanical installation	16
Removing the front cover	16
Electrical installation	16
Relay connections	20
Interfacing with fire alarm panels	20
Connecting the detector to an APIC	21
Setting the detector address	22
Address table	23
Connecting the detector to a SenseNET/RS-485 detector network	25
Final installation	27
Removing the detector	27
Configuring the detector after installation	27
List of programmable functions	28
Connecting to a PC	29
Event log	31

Introduction

This topic provides information necessary to install the detector system.

To install the detector:

1. Unpack the shipping carton. Ensure that the package contains a CD-ROM, two ferrite rings, two cable glands, and the unit.
2. Determine the optimum location for the detector.
3. Mount APIC or Relay Card inside the detector, if required.
4. Mount the docking station.
5. Connect the docking station to the sampling pipe network.
6. Mount the detector to the docking station.

Installation should only be done by factory-trained technicians in accordance with applicable installation requirements.

Note: Power should be turned off during installation.

Antistatic precautions

This system contains static-sensitive components. Always ground yourself with a proper wrist strap before handling any circuits.

Caution: When handling any electric components or printed circuit boards, antistatic precautions must be followed. Failure to do so may result in component damage.

Electro-static discharge can be reduced by adhering to the following guidelines:

- Always use conductive or antistatic containers for transportation and storage, if returning any item.
- Wear a wrist strap while handling devices and ensure that a good ground is maintained throughout the installation process.
- Never subject a static sensitive device to sliding movement over an ungrounded surface and avoid any direct contact with the pins or connections.
- Avoid placing sensitive devices onto plastic or vinyl surfaces.
- Minimise the handling of sensitive devices and printed circuit boards (PCBs).

General installation guidelines

The following is a brief set of guidelines on installing detectors:

- The detector should normally be mounted at a level where there is easy access to the RS-232 serial port for configuration and programming.
- The exhaust air from the unit must not be impeded in any way. If the unit is mounted where the air pressure differs from the sampling location (for example an air duct), then a pipe must be, then a pipe must be routed from the exhaust port back to the same air pressure zone as the sampling holes.
- Sampling holes should be free from burrs and swarf.
- All signal cables must be suitable for the application. The specific type of cable will normally depend upon the local fire regulations.
- The unit must not be placed in areas where either the temperature or humidity is outside the specified operating range.
- The unit should not be placed in close proximity to any equipment expected to generate high Radio Frequency levels (such as radio alarms) or units generating high levels of electrical energy (such as large electric motors or generators).

Docking station

The basic principle behind installation of the detector is that all wiring and pipework is installed using a docking station. This is a convenient feature which means that the detector can be dismantled or replaced without disturbing any wiring or installed pipework.

The docking station inlet (sampling) ports and exhaust port is used to interface with the pipe network. The inlet ports are used for aspirating the pipework network. The exhaust port allows the detector exhaust air to be routed back to the sampling area, when differing atmospheric pressures require this. Refer to Figure 4 on page 10.

Figure 4: Docking station

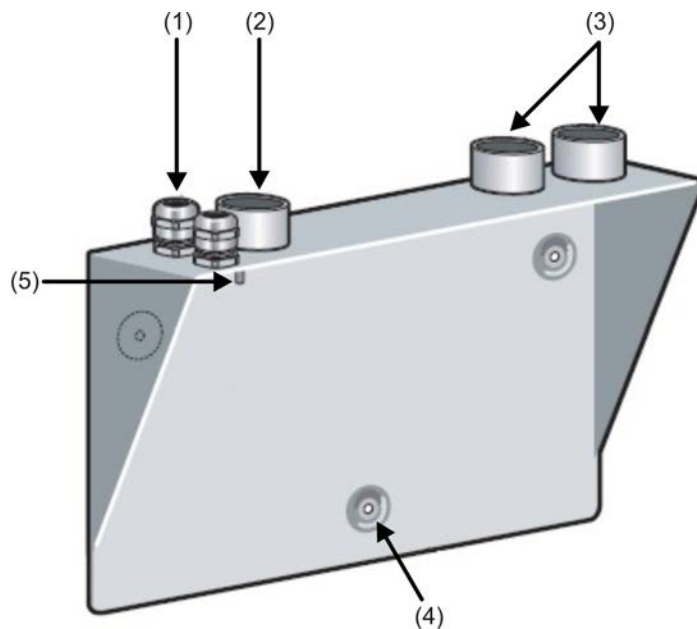

- (1) Cable gland
- (2) Exhaust port
- (3) Sampling port

- (4) Mounting screw holes
- (5) Ground stud

Application

The detector is intended to provide small area incipient fire detection. This means that it is suitable for the substantial range of applications typified by small compartmentalised rooms, warehouse racking, or pieces of electronic or electromechanical equipment where it is desirable to achieve individual incipient fire reporting. In compartmentalised rooms, each compartment would normally use an individual aspirating detector.

The detector is not intended to protect large areas, or to sample from areas where there may be any difference in airflow rates or pressure differentials. If detection in environments conforming to these descriptions is required, other type detectors should be used.

System design

Simple designs with short sampling pipes produce the best results. Complex sampling pipe runs should be avoided with the detector. The use of T-branch pipes is not recommended. The detector is fitted with two sampling pipe inlets as standard. It is always preferable to use two shorter pipes as opposed to one longer pipe. If two sampling pipes are used, care should be taken to keep the sampling pipe lengths and number of sampling holes on each pipe within 10% of the other. This can be verified using the PipeCAD system design software. Unused sampling pipe inlets should be fitted with pipe bungs.

Maximum length of sampling pipe used with the detector is 100 m in *still air* with 25 sampling holes (or Capillary Remote Sampling Points). This will provide a transport time from the end of the sampling pipe within 120 seconds. If the protected area has airflow present, the maximum permitted sampling pipe length will be reduced. In areas or applications where the airflow rate exceeds 1 metre per second, maximum sampling pipe length is reduced to 40 m.

In order for the installation to conform to EN 54-20, pipes must conform at least to EN61386-1 Class 1131.

Note: PipeCAD pipe modeling software must be used when designing a pipe network and verifying its performance. Refer to the *PipeCAD System Design and Installation User Manual* or complete instructions on how to design and install an air sampling pipe network.

Always locate the sampling points in positions to which smoke may reasonably be expected to travel. For example, do not expect ceiling mounted sampling points to operate satisfactorily if air flow from air-conditioning systems keeps the cool smoke from an incipient fire from reaching ceiling level. In this instance, it is usually better to locate the sampling pipe directly in the airflow (for example, across the return air register of an air conditioning unit).

Note: There is no substitute for carrying out smoke tests prior to installation of pipework to indicate suitable sampling point location.

No more than two air handling units may be protected with one detector. In this application, ensure that the sampling pipe is raised clear of high velocity air in the immediate vicinity of the air intake grill on standoff posts as shown in Figure 5.

Figure 5: Air handling unit in vicinity of the detector

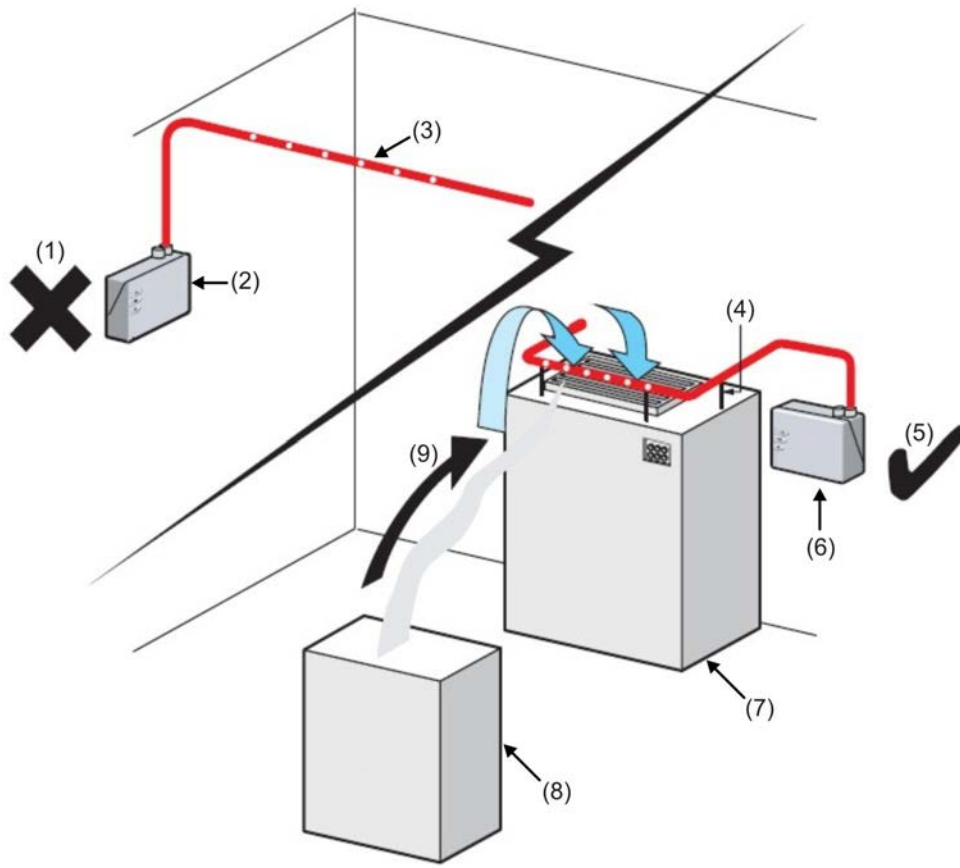

- (1) Incorrect
- (2) Detector
- (3) Sampling pipe
- (4) Standoff posts
- (5) Correct

- (6) Detector
- (7) AHU
- (8) Equipment cabinet
- (9) Direction of smoke

Below or above the ceiling installations

The detector is supplied with a docking station (as shown in Figure 4 on page 10). This allows the detector to sample from areas which may be at different air pressure from the detector location. Typical uses are for air duct sampling and allowing the installation of the detector in under-floor or ceiling voids or when sampling from pieces of computer related equipment. See Figure 6 and Figure 7.

Figure 6: Installation of pipework above ceiling with exposed detector (piped exhaust)

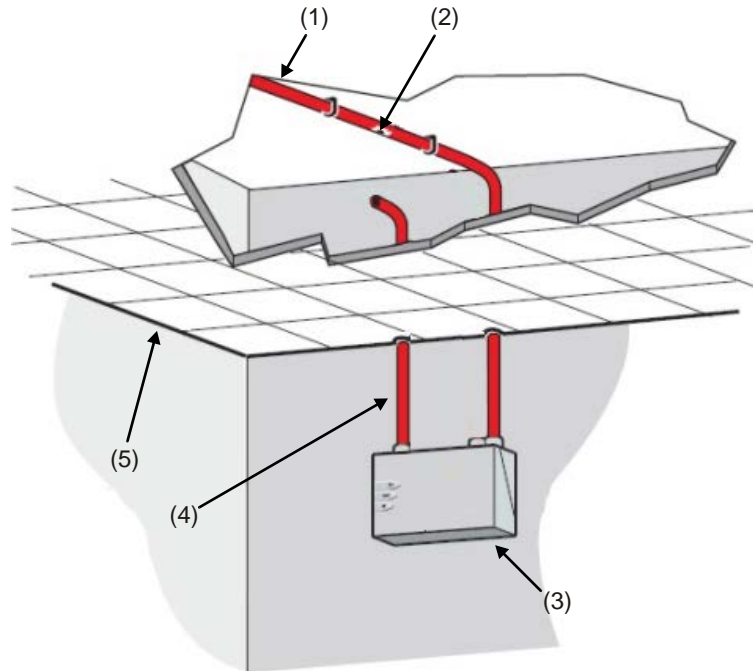

- (1) Sampling pipe
- (2) Sampling hole
- (3) Detector

- (4) Exhaust pipe
- (5) False ceiling

Figure 7: Installation of pipework above ceiling with detector mounted in ceiling void (no exhaust piping)

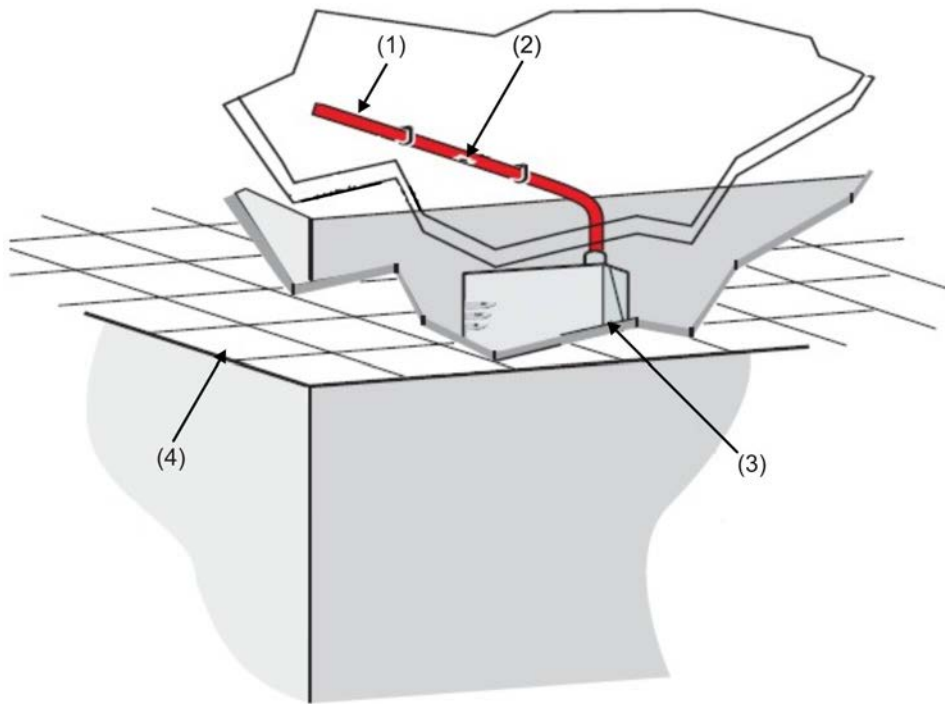

(1) Sampling pipe
(2) Sampling hole

(3) Detector
(4) False ceiling

Table 2 below contains a list of procedural guidelines for installation of the detector.

Table 2: Procedural guidelines

Do	Don't
<p>Ensure that the ClassiFire alarm factor is appropriately set.</p> <p>Ensure that the power and signal cables are correctly connected before powering up by use of cable identifiers or electrical continuity checks. Incorrect connection could damage the detector.</p> <p>Ensure that cable of an appropriate approved type is used for interconnection.</p> <p>Place sampling points so that the detector will be able to detect smoke at the earliest opportunity.</p> <p>Ensure that the detector exhaust is in an area with the same atmospheric pressure as the sample pipes, either by placing the detector physically in the protected area or by leading a pipe from the detector exhaust to the protected area.</p> <p>Ensure that the environment of the protected area is within the environmental operating parameters of the detector.</p> <p>Close unused pipe inlet ports on the detector to ensure optimal operation.</p> <p>Set the appropriate ClassiFire alarm factor for the area to be detected.</p> <p>Set the detector address switches correctly when used in a network.</p> <p>Ensure that the detector is properly grounded.</p>	<p>Drop the detector.</p> <p>Install detectors in damp or exposed areas.</p> <p>Remove or connect boards when the detector is powered up.</p> <p>Connect internal 0 volt terminals to local earth.</p> <p>Attempt to reuse dust separator (filter) cartridges once removed.</p> <p>Attempt to adjust or alter detector settings other than via the user-programmable functions. Any attempts to adjust the laser potentiometer are detectable and will void the warranty on the product.</p> <p>Place the detector near high power RF sources.</p> <p>Place the detector so close to other equipment that there is insufficient room to access and change the dust separator (filter) or access the RS-232 connector.</p> <p>Use sampling pipe of less than 27 mm (1 inch) outside diameter without a suitable 27 mm (1 inch) pipe adapter. It is important that there are no leaks where the pipe connects to the detector.</p> <p>Use excessive force when fitting sampling pipes as this may damage the detector.</p>

Mechanical installation

The docking station is connected to the installed sampling pipework and fixed to the mounting surface using three screws of a type appropriate to the mounting surface. Ensure that the sampling and/or exhaust pipes are securely seated in the pipe ports before securing. If using a piped exhaust docking station, be sure that the sampling and exhaust pipes are fitted into the relevant ports as shown in Figure 4 on page 10.

Removing the front cover

To remove the front cover, unfasten the six attachment screws on the front of the unit. The cover may then be removed.

Electrical installation

The detector is supplied with removable terminal blocks (Refer to Figure 3 on page 6). These may be removed from their sockets by lifting them up at right angles to the circuit board.

Take note of the orientation of each terminal block and its function before removing it. It may also be beneficial to mark the connection wires with suitable identification labels or colored rings to aid in the connection process.

Each detector is supplied with a pair of RF suppression ferrite rings. To ensure compliance with all relevant EMC requirements, the conductors of each cable should be wound once around a ferrite as shown here before entering the relevant connector. Power conductors should be on a separate ferrite, but different forms of signal conductor (e.g. RS485 and relays) can share the same ferrite. There should be about 30 mm (1-1/4 in.) of wire between the end of the ferrite and the terminal block to give adequate stress relief. To achieve this, it is necessary to strip back the cable screen approximately 130 mm (5 in.). The screen should be terminated under the cable gland cap as shown in Figure 8.

Figure 8: Looping relay connection wires around a suppression ferrite

WARNING: Electrocutation hazard. All connections should be made with the power turned off.

Power supply connections

The power supply cable should be the shielded (screened) type and should be led through the metal cable gland provided, leaving about 35 mm (1-1/4 in.) of the cable extending from the bottom of the cable gland. Depending on the type of cable used, it may be necessary to increase the diameter of the cable with sleeving or insulating tape to ensure that the cable is firmly held when the cable gland is fully tightened.

Note: It is important to be aware of the orientation of the terminal block before removing it.

To connect the power supply:

1. Remove the detector front cover, and then detach the power supply terminal block, located at the top left inside the detector. (Refer to Figure 2 on page 5 for a photograph of the detector with the front cover removed. Refer to Figure 9 on page 18 for a detailed photograph of the power supply terminals.)
2. Detach the power supply terminal block.
3. Connect 0 V and +24 VDC to the “0V” and “24V” screw terminals respectively.
4. Connect the shielded (screened) wire to the ground stud on the docking station.
5. Connect a second wire from the “Earth” terminal to the docking station ground stud. Figure 4 on page 10 shows the location of the ground stud for both types of docking stations.
6. Connect the ground wires to the ground stud.
7. Replace the terminal block with the same orientation as when removed.

Figure 9: Detector power supply terminals

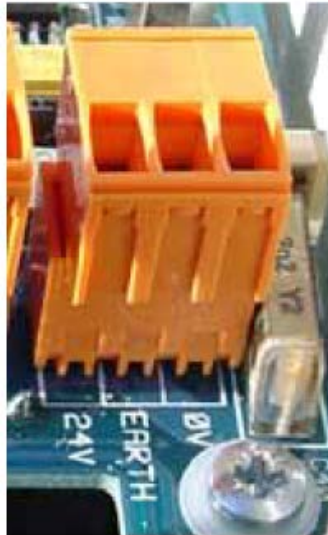

Signal connections

To connect the signal wire:

1. Lead a suitable wire type (RS-485 cable 9841, 120 ohm shielded (screened) twisted pair or equivalent) through the second cable gland.
2. Tighten it into position with approximately 35 mm (1-1/4 inch) of cable from the bottom of the cable gland.
3. Remove either the three-way terminal block next to the power supply socket (if connecting the detector to a SenseNET system) or the four-way “Bus” terminal block (if connecting the detector to an alarm panel in conjunction with the APIC addressable bus card). Refer to Figure 10 for an illustration of the terminals and “Setting the detector address” on page 22 for details on addressing.

Figure 10: APIC address and RS-485/SenseNET terminals

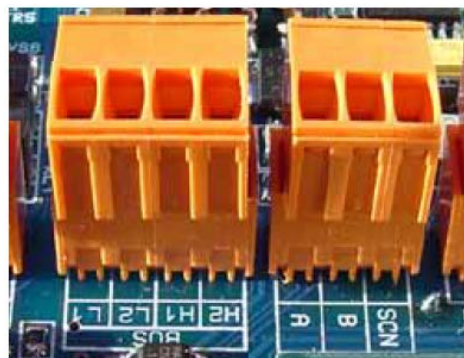

(1)

(2)

(1) APIC Address terminal

(2) RS-485 / SenseNET terminals

For example, in a networked system using screened cable, connect the screen wires to the “SCN” terminal, Bus A wires to the “A” terminal and Bus B wires to the “B” terminal.

If the detector is in the middle of a networked chain (with input and output connections) it may be more convenient to link the common Bus A, Bus B, and screen wires to single A, B and screen wires for linking to the terminal block.

Figure 11 below shows the power and signal connections to the docking station for connection to a single network cable.

Figure 11: Power and signal connections to the docking station

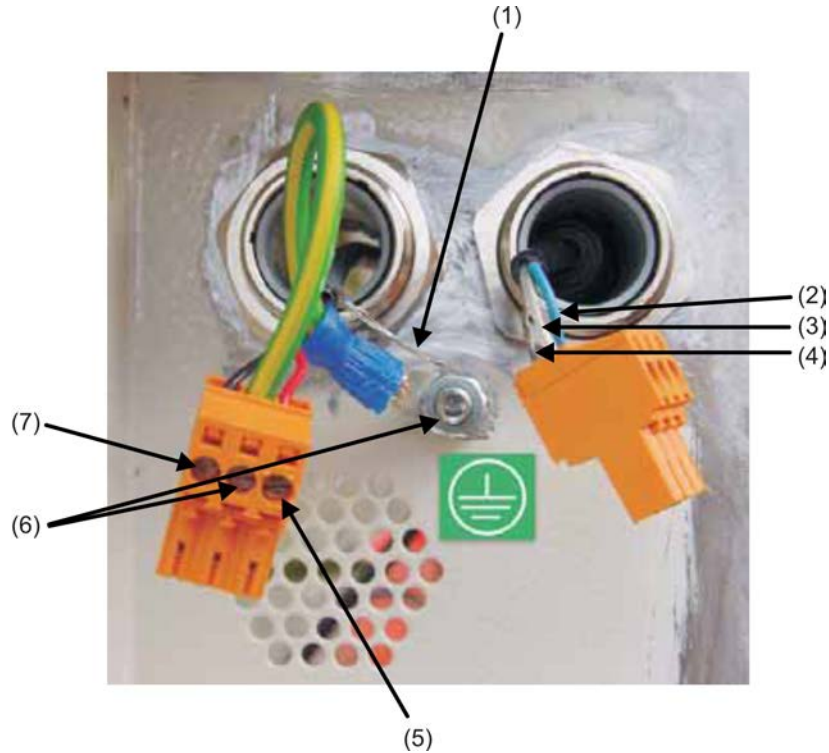

- | | |
|---|---|
| (1) Power supply shielded wire to ground stud | (5) Power supply to +24V wire |
| (2) RS-485/SenseNET Bus A wire | (6) Wire from “earth” terminal to ground stud |
| (3) RS-485/SenseNET Bus B wire | (7) Power supply 0V wire |
| (4) RS-485/SenseNET Bus shielded wire | |

Relay connections

The detector includes an Alarm relay (corresponding to the FIRE 1 alarm level), which closes on alarm, and a general Fault relay, which opens on any fault condition or on power-down (see Figure 12 below). The relays are of the volt-free type, with a maximum current capacity of 500 mA at 30 VDC.

Figure 12: Fault and Alarm relay contacts

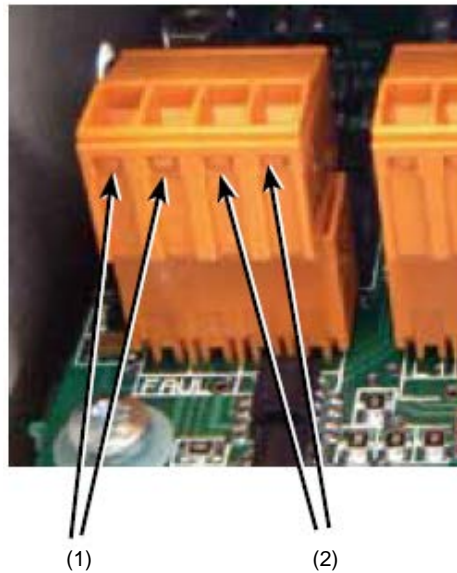

(1) Fault relay contacts

(2) Alarm relay contacts

Interfacing with fire alarm panels

Because of the flexible nature of the detector and the many possible configurations, there are many options for interfacing the detectors to the fire panel. The detector provides the following methods of interfacing with fire alarm panels:

- To conventional fire alarm panels using the detector's ALARM and FAULT relay contacts
- To addressable fire alarm panels via Addressable Programmable Interface Cards (APICs)

APICs, which can be mounted inside the detector, may simplify installation when connecting to addressable signaling line circuits (SLC). The APIC used is completely dependent on the SLC protocol, and therefore, the make and model of the fire alarm panel.

WARNING: Incompatible APIC panel combinations may result in a non-operational system which may fail to perform during an event, with resultant loss of life and/or property.

APICs plug into a connector on the main PCB via a ribbon cable. Once plugged in, the SLC in and out are connected to the main PCB addressable bus terminals and the address DIP switches are set to the SLC address. APICs have two modes of operation: single address and multiple address.

When the interface is set to single address mode, the card appears at a single address on the SLC and the detector status is read from that address.

Multi-address mode is used when monitoring the status of multiple detectors with consecutive addresses from a single SLC. Multiple address mode is normally only used in the Command Mode.

Connecting the detector to an APIC

The APIC is fitted to the four mounting studs on the detector PCB using the supplied screws as shown Figure 13 on page 22.

The connections to the Fire Panel are made using the BUS L1 and H1 (bus 1 input and output) and the BUS L2 and H2 (bus 2 input and output) terminal connectors shown in Figure 10 on page 18.

The only settings that need to be made are on the APIC address DIP switches. The start loop address is entered on SW1 and the end loop address on SW2. In the case of a single detector the start and end addresses are the same.

Note: The detector address on the SenseNET loop and the fire panel addressable protocol address are the same, i.e. no address translation is performed. Some protocols may not support all the available alarm levels and fault reporting is usually a general fault with no detailed fault information. Please consult the specific APIC protocol documentation for more information.

Figure 13: APIC connections

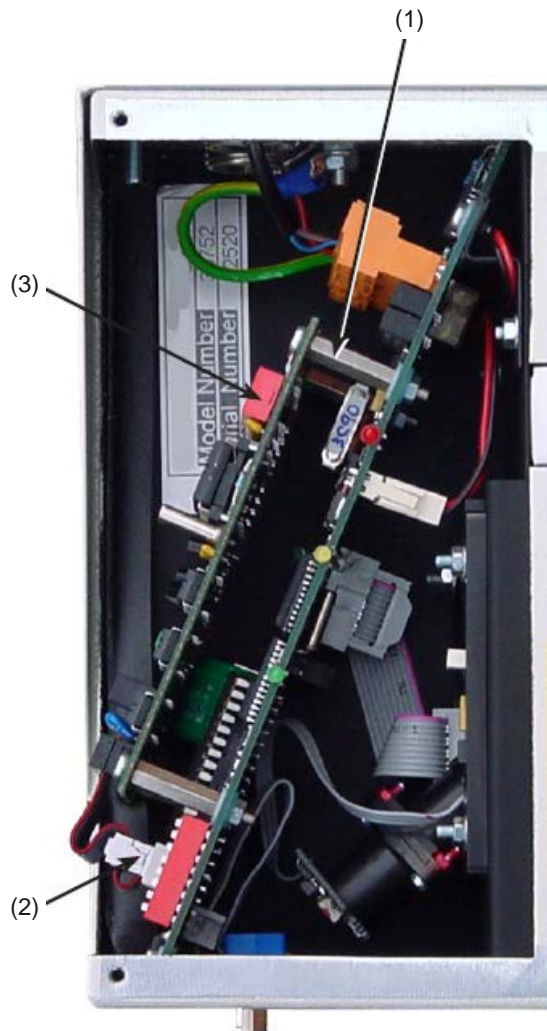

(1) Mounting studs (4X)

(2) APIC Interface connection

(3) APIC address switch (2x)

Setting the detector address

In order to identify itself to the PC command module or fire panel, each detector needs to have a unique address ranging from 1 to 127. The detector address is set on the DIP switch SW1 at the bottom left of the opened detector on the main circuit board. The switch settings are up for 1 and down for 0, and the detector address is set as a 7-bit binary code (switch 8 equates to a value of 128 and so is outside the usable address range). Refer to Figure 2 on page 5 for the location of detector DIP switches.

Figure 14 shows a sample DIP switch setting.

The address equates to 01100011 in binary, or:

$$(1 \times 1) + (1 \times 2) + (0 \times 4) + (0 \times 8) + (0 \times 16) + (1 \times 32) + (1 \times 64) + (0 \times 128) = 99$$

The full range of available addresses and their relevant switch settings are provided in Table 3 on page 24 for reference.

Figure 14: Sample DIP switch settings

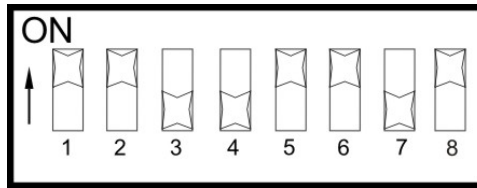

Address table

Addresses chosen for detectors do not have to be consecutive or in a given order so long as they are all different. Table 3 on page 24 provides the address table for detectors.

Table 3: Address table

Address	1	2	3	4	5	6	7	8
1	1	0	0	0	0	0	0	0
2	0	1	0	0	0	0	0	0
3	1	1	0	0	0	0	0	0
4	0	0	1	0	0	0	0	0
5	1	0	1	0	0	0	0	0
6	0	1	1	0	0	0	0	0
7	1	1	1	0	0	0	0	0
8	0	0	0	1	0	0	0	0
9	1	0	0	1	0	0	0	0
10	0	1	0	1	0	0	0	0
11	1	1	0	1	0	0	0	0
12	0	0	1	1	0	0	0	0
13	1	0	1	1	0	0	0	0
14	0	1	1	1	0	0	0	0
15	1	1	1	1	0	0	0	0
16	0	0	0	0	1	0	0	0
17	1	0	0	0	1	0	0	0
18	0	1	0	0	1	0	0	0
19	1	1	0	0	1	0	0	0
20	0	0	1	0	1	0	0	0
21	1	0	1	0	1	0	0	0
22	0	1	1	0	1	0	0	0
23	1	1	1	0	1	0	0	0
24	0	0	0	1	1	0	0	0
25	1	0	0	1	1	0	0	0
26	0	1	0	1	1	0	0	0
27	1	1	0	1	1	0	0	0
28	0	0	1	1	1	0	0	0
29	1	0	1	1	1	0	0	0
30	0	1	1	1	1	0	0	0
31	1	1	1	1	1	0	0	0
32	0	0	0	0	0	1	0	0
33	1	0	0	0	0	1	0	0
34	0	1	0	0	0	1	0	0
35	1	1	0	0	0	1	0	0
36	0	0	1	0	0	1	0	0
37	1	0	1	0	0	1	0	0
38	0	1	1	0	0	1	0	0
39	1	1	1	0	0	1	0	0
40	0	0	0	1	0	1	0	0
41	1	0	0	1	0	1	0	0
42	0	1	0	1	0	1	0	0
43	1	1	0	1	0	1	0	0
44	0	0	1	1	0	1	0	0
45	1	0	1	1	0	1	0	0
46	0	1	1	1	0	1	0	0
47	1	1	1	1	0	1	0	0
48	0	0	0	0	1	1	0	0
49	1	0	0	0	1	1	0	0
50	0	1	0	0	1	1	0	0
51	1	1	0	0	1	1	0	0
52	0	0	1	0	1	1	0	0
53	0	0	0	0	0	0	0	0
54	0	0	0	0	0	0	0	0
55	0	0	0	0	0	0	0	0
56	0	0	0	0	0	0	0	0
57	0	0	0	0	0	0	0	0
58	0	0	0	0	0	0	0	0
59	0	0	0	0	0	0	0	0
60	0	0	0	0	0	0	0	0
61	0	0	0	0	0	0	0	0
62	0	0	0	0	0	0	0	0
63	0	0	0	0	0	0	0	0
64	0	0	0	0	0	0	0	0
65	1	0	0	0	0	0	1	0
66	0	1	0	0	0	0	1	0
67	1	1	0	0	0	0	1	0
68	0	0	1	0	0	0	1	0
69	1	0	1	0	0	0	1	0
70	0	1	1	0	0	0	1	0
71	1	1	1	0	0	0	1	0
72	0	0	0	1	0	0	1	0
73	1	0	0	1	0	0	1	0
74	0	1	0	1	0	0	1	0
75	1	1	0	1	0	0	1	0
76	0	0	1	1	0	0	1	0
77	1	0	1	1	0	0	1	0
78	0	1	1	1	0	0	1	0
79	1	1	1	1	0	0	1	0
80	0	0	0	0	1	0	1	0
81	1	0	0	0	1	0	1	0
82	0	1	0	0	1	0	1	0
83	1	1	0	0	1	0	1	0
84	0	0	1	0	1	0	1	0
85	1	0	1	0	1	0	1	0
86	0	1	1	0	1	0	1	0
87	1	1	1	0	1	0	1	0
88	0	0	0	1	1	0	1	0
89	1	0	0	1	1	0	1	0
90	0	1	0	1	1	0	1	0
91	1	1	0	1	1	0	1	0
92	0	0	1	1	1	0	1	0
93	1	0	1	1	1	0	1	0
94	0	1	1	1	1	0	1	0
95	1	1	1	1	1	0	1	0
96	0	0	0	0	0	1	1	0
97	1	0	0	0	0	1	1	0
98	0	1	0	0	0	1	1	0
99	1	1	0	0	0	1	1	0
100	0	0	1	0	0	1	1	0
101	1	0	1	0	0	1	1	0
102	0	1	1	0	0	1	1	0
103	1	1	1	0	0	1	1	0
104	0	0	0	1	0	1	1	0
105	1	0	0	1	0	1	1	0
106	0	1	0	1	0	1	1	0
107	1	1	0	1	0	1	1	0
108	0	0	1	1	0	1	1	0
109	1	0	1	1	0	1	1	0
110	0	1	1	1	0	1	1	0
111	1	1	1	1	0	1	1	0
112	0	0	0	0	1	1	1	0
113	1	0	0	0	1	1	1	0
114	0	1	0	0	1	1	1	0
115	1	1	0	0	1	1	1	0
116	0	0	1	0	1	1	1	0
117	1	0	1	0	1	1	1	0

53	1	0	1	0	1	1	0	0
54	0	1	1	0	1	1	0	0
55	1	1	1	0	1	1	0	0
56	0	0	0	1	1	1	0	0
57	1	0	0	1	1	1	0	0
58	0	1	0	1	1	1	0	0
59	1	1	0	1	1	1	0	0
60	0	0	1	1	1	1	0	0
61	1	0	1	1	1	1	0	0
62	0	1	1	1	1	1	0	0
63	1	1	1	1	1	1	0	0
64	0	0	0	0	0	0	1	0

118	0	1	1	0	1	1	1	0
119	1	1	1	0	1	1	1	0
120	0	0	0	1	1	1	1	0
121	1	0	0	1	1	1	1	0
122	0	1	0	1	1	1	1	0
123	1	1	0	1	1	1	1	0
124	0	0	1	1	1	1	1	0
125	1	0	1	1	1	1	1	0
126	0	1	1	1	1	1	1	0
127	1	1	1	1	1	1	1	0

Connecting the detector to a SenseNET/RS-485 detector network

Up to 127 detectors may be linked in a single SenseNET bus, supporting a total length of wire between adjacent detectors of up to 1.2 km (3/4 mile).

Figure 15 on page 26 shows an example of two detectors linked into a 127-detector bus with a command module and a number of HSSD-2 detectors. It will be noted that whereas the HSSD-2 detectors have two input/output buses (1A/1B and 2A/2B), this detector has only a single such bus (A/B). Therefore, each bus terminal has an input and an output wire, compared with a single wire in each terminal in the HSSD-2.

Figure 15: Connecting the detector to a SenseNET network

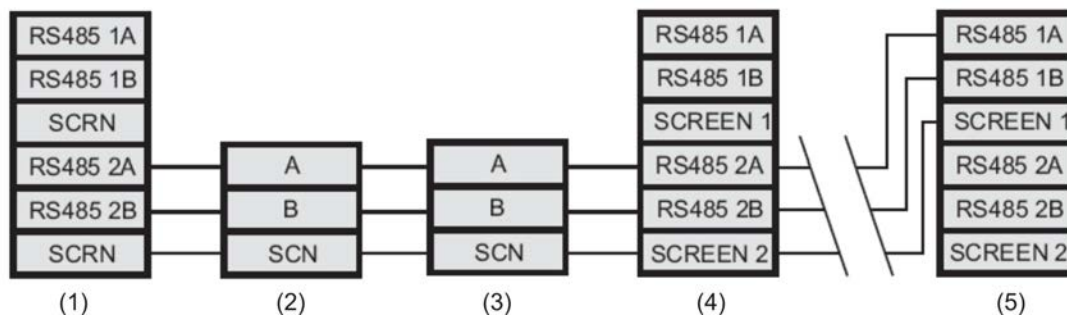

- (1) Command module
- (2) Detector 1
- (3) Detector 2
- (4) Detector 3 (HSSD-2)
- (5) Detector 127 (HSSD-2)

It is easy to join the input and output wires for each bus and screen connection together and to solder or crimp a single wire or connecting ferrule to each wire pair so that they are easier to fit into the screw terminals. If this is performed, it is recommended that bare wire joints be insulated to prevent possible shorting of the data bus, which will cause a drop-out of data on the SenseNET bus.

In the example shown in Figure 15 above, there could be a total length of RS-485 cable of up to 1.2 km (3/4 mile) between the command module and detector 3, since these are all on a single bus. However, detector 3 is a HSSD-2 which has a second communications bus (RS-485 bus 2) and an RS-485 repeater. This allows a further total of 1.2 km (3/4 mile) of cable until the next HSSD-2 in the RS-485 loop.

In the example shown in Figure 15, if detectors 4-126 (not shown) are all this type of detector, then the total length of wiring between Detectors 3 and 127 would be limited to 1.2 km (3/4 mile). However, each additional HSSD-2 detector wired up using both RS-485 buses would allow an additional 1.2 km (3/4 mile) of cabling to be added to the RS-485 loop.

Final installation

Once the power and signal connections are made, slide the detector body up into the docking station and fasten it into position using the M4 pan head screws provided. Slot the power and signal terminal blocks into the relevant sockets on the detector PCB (which will only click fully home in the correct orientation). Lastly, replace the detector cover using the six pan head screws provided. Refer to Figure 16.

Note: The detector is designed solely for operation with the front cover securely fitted using all six fixing screws.

Removing the detector

Removing the detector is the reverse of the installation process, leaving the pipework and wiring connections installed in the docking station (as shown in Figure 4 on page 10). See Figure 16.

Figure 16: Final installation of the detector

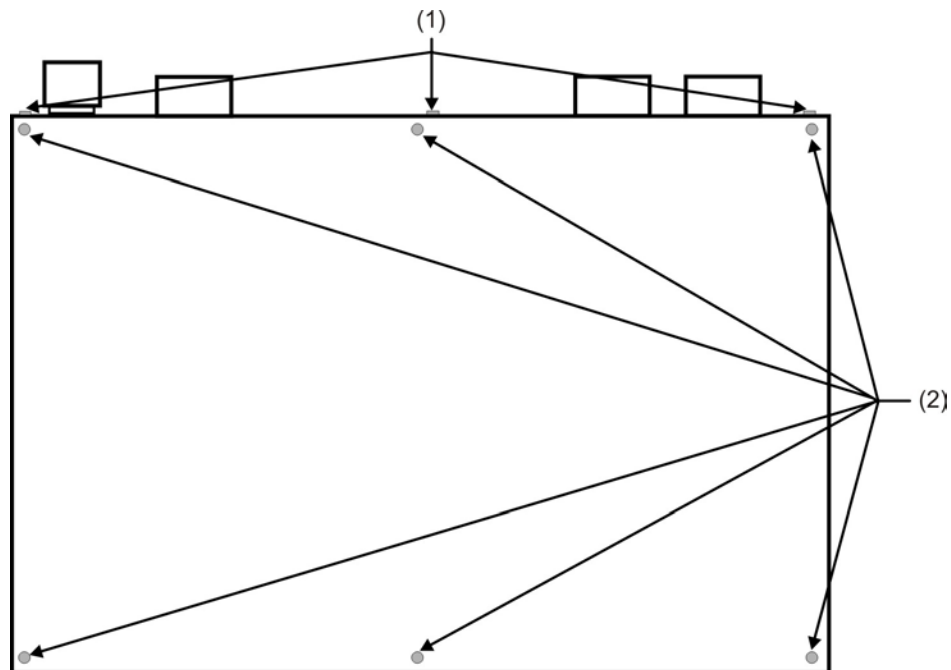

- (1) Docking station attachment screws (3X)
- (2) Cover attachment screws 6X)

Configuring the detector after installation

The detector programmable functions are accessed using a PC (connected to the detector) running either the remote configuration software or SenseNET programs.

Remote Configuration software

Provided free of charge with every detector, the Remote Configuration software package enables the user to set up and configure the programmable functions of one or more detectors or command module from a computer connected via an RS-232 serial cable. Complete instructions on how to install, launch and use the Remote software are provided in *the Remote Configuration Software User Manual* under separate cover.

SenseNET

The SenseNET software is available for purchase. SenseNET software can configure and manage a large network of detectors with a simple, streamlined graphical user interface from a computer connected to a detector or command module via an RS-232 serial cable or RS-485 converter interface. Complete instructions on how to install, launch and use the SenseNET software are provided in the *SenseNET Software User Manual* under separate cover.

Note: Since the detector does not include a front panel display or keypad, programmable functions cannot be accessed via the unit itself.

Refer to “Connecting to a PC” on page 29 of this manual for instructions on how to connect a PC to the detector.

List of programmable functions

In both the Remote Configuration and SenseNET software programs, the tabbed Functions Settings window contains all of the available programmable functions.

For details about these functions, refer to the appropriate manuals provided separately:

- *Remote Configuration Software User Manual*
- *SenseNET Software User Manual*

To change one of the programmable functions, go to the relevant tab, make the change, and then select <OK> to save the changes to the detector’s internal firmware.

The following programmable functions are available:

- Time and Date
- Alarm Levels
- Alarm Delays
- ClassiFire Override (when optional Input/Relay card is installed)
- Alarm Factor
- LDD Enable
- FastLearn Enable
- Auto FastLearn Enable
- ClassiFire 3D
- Demo Mode
- Day Start/Night Start

- Disable Day/Night Switching
- Remote Functions (when optional Input/Relay card is installed)
- Programmed Isolate
- Latching Alarms
- Latching Faults
- Cascading Alarms
- Device Type (reference only)
- Firmware Version
- Run-time Hours
- Watchdog Count (reference only)
- Device Text
- Reference Detector
- Reference Enable
- Reference Level
- Reference Back-off
- Flow Rate (reference only)
- Flow High Limit
- Flow Low Limit
- Flow Fault Delay
- Access Code
- Chart Recording Rate
- Separator Condition (reference only)
- Separator Change Date
- Factory Default
- Reset
- Real Time ClassiFire Viewer Histograms (reference only)
- Chart Recording

Connecting to a PC

To connect a single stand-alone detector to a PC, connect the PC's serial port directly to the detector's 9-way RS-232 port. Connections for this cable are shown in Figure 17 on page 30.

Figure 17: RS-232 cable connections

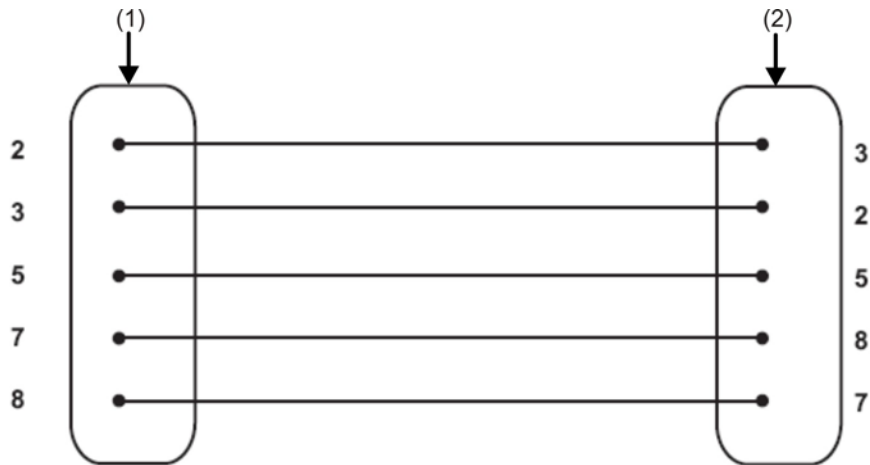

- (1) 9 pin female "D" connector
- (2) 9 pin female "D" connector

Figure 18 shows the RS-232 cable connection from the detector to a PC.

Figure 18: Detector serial port connection for a PC

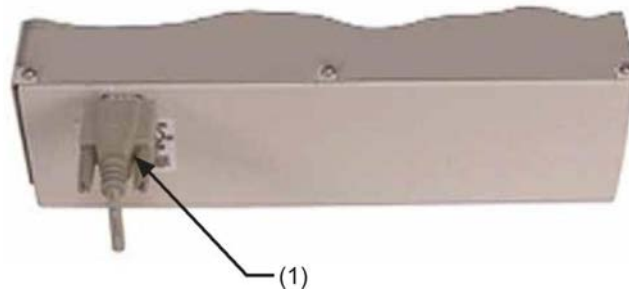

- (1) Serial port connection (to PC)

Event log

The Event Log is a record of detector events such as faults, alarms and function changes. It is stored inside an operating detector and is updated whenever an event occurs. The event log is nonvolatile, which means that it is retained when the detector is turned off. The last 200 detector events may be stored.

An event is defined as:

- A change to any programmed function
- A signal received from an external controller such as the remote software, APIC or SenseNET
- A detector output level meeting or exceeding the Pre-Alarm, Aux, Fire 1, or Fire 2 alarm thresholds
- A fault condition such as a flow or dust separator (filter) fault
- A start of day or night operation
- Demonstration Mode start
- FastLearn start or stop
- Power on or off

Events can either be viewed on a PC screen or downloaded to disk by running the Remote Configuration program.

When the detector event log is full (200 events have been logged) and a new event occurs, the oldest event in the log is deleted (first-in, first-out).

To download the event log, connect a PC to the detector serial port and run the Remote software or SenseNET programs. For details, see the *Remote Configuration Software User Manual* or the *SenseNET Software User Manual*.

Chapter 3

Commissioning

Summary

This chapter provides information to commission the detection system.

Content

Introduction 34

Precommissioning preparation 34

Commissioning checklist 34

Introduction

This chapter covers the commissioning procedures for the detector. Commissioning strategy initially depends upon the environment in which the detector is installed. For instance, the test for a computer room (in a relatively clean environment) would be very different from, say, a flour mill, with a high level of airborne particulate content.

A widely accepted standard for computer rooms or EDP areas is British Standard BS6266, equipment overheating at a stage well before combustion. To perform the test electrically overload a 1-metre length of PVC insulated wire of 10/0.1mm gauge for one minute using an appropriate power supply. The detector has two minutes from the end of the wire burn to give an alarm indication.

For areas with higher levels of background particulate matter testing methodology would be similar to that of standard point detectors.

Commissioning should only be done by factory-trained technicians in accordance with applicable standards.

Precommissioning preparation

Commissioning should be performed after all construction has been completed and cleaned of any lingering post-construction dirt. If ambient monitoring conditions are recorded before the installation is cleaned up, they may not accurately reflect actual normal operating conditions that need to be used as reference data for follow-up maintenance procedures and tests.

Commissioning checklist

The following brief checklist allows quick setup of the detector. This procedure will be adequate for most standard installations.

To commission the detector:

1. Before powering up the detector, visually check all cabling to ensure correct connection. If wire identification is not immediately clear (e.g. by use of different colored wires or wire identification sleeves), an electrical check should be made.

Caution: Ensure that all wiring connections are checked prior to powering up the detector. Incorrect wiring of the detector will cause permanent damage to the detector.

2. Connect the detector to a PC and set the detector address on the DIP Switches and APIC board (if applicable). Refer to “Signal connections” on page 18 and “Relay connections” on page 20 for more information.

3. Power up the detector.
4. Ensure all detectors in the network area are clear of troubles and alarms (if applicable).
5. Launch either the Remote Configuration software or SenseNET program on the computer, enter the access code, and then select the Function Settings window.
6. Verify that the time and date are correct in the Time and date tab.
7. Set an appropriate alarm factor, as shown in Table 4 below, for the protected environment in the Alarm levels and delays tab. The detector will automatically perform FastLearn for the new alarm factor (takes approximately 15 minutes). The OK indicator on the front panel will begin to flash. If using Day/Night switching, check that the Day Start and Night Start times reflect site operations.
8. While the detector is still in FastLearn mode, place a checkmark next to the Demo mode command at the bottom of the Alarm levels and delays screen. The detector will enter Demo mode (where it estimates its final sensitivity) immediately after the FastLearn cycle has finished.

Note: Checking the Demo mode box only puts the detector into Demo mode while the detector is performing a FastLearn. It has no effect at any other time.

9. Verify that the FastLearn has concluded (the OK indicator has stopped flashing). With the detector in demo mode, perform any necessary smoke tests, ensuring that the detector reacts appropriately, and let the smoke fully dissipate.
10. Perform another FastLearn, this time NOT putting the detector into demo mode. Do this by placing a checkmark next to the FastLearn Enable command in the Alarm levels and delays screen. The OK indicator on the front panel will begin to flash.
11. The detector will generate no alarms during the 15 minute FastLearn period and, after this, the detector will operate at a reduced sensitivity for 24 hours while ClassiFire acclimates to the protected environment and sets up appropriate day and night sensitivity settings.
12. If desired, exit the remote configuration software or SenseNET software, power down the PC and remove it from the detector serial port.

Table 4: Suggested settings for ClassiFire alarms

Alarm factor	Sensitivity	Probability of nuisance alarm	Suggested protected area
0	Extremely High	Once per year	Semiconductor manufacturing clean room
1	High	Once per 5 years	Computer room
2	High	Once per 10 years	Non-smoking office
3	High	Once per 50 years	Clean factory

Alarm factor	Sensitivity	Probability of nuisance alarm	Suggested protected area
4	Medium	Once per 1,000 years	Warehouse
5	Medium	Once per 5,000 years	Warehouse with diesel trucks operating
6	Medium	Once per 10,000 years	Warehouse with diesel trucks operating
7	Low	Once per 20,000 years	Warehouse with diesel trucks operating
8	Low	Once per 100,000 years	Warehouse with diesel trucks operating

Chapter 4

Troubleshooting

Summary

This chapter provides information to troubleshoot the detection system.

Content

Troubleshooting the detector 38

Troubleshooting the detector

This chapter provides some possible solutions if a problem should occur with your detector. If the problem is not addressed in this chapter or, if after performing the suggested actions, the problem persists, contact Technical Support.

Note: Consult either the *Remote Configuration Software User Manual* or *SenseNET Software User Manual* for more information about the solutions or corrective actions discussed here.

Table 5: Troubleshooting guide

Problem	Solution/Corrective Action
Nuisance alarms occur too often	<p>Check that the ClassiFire alarm factor setting is appropriate for the normal working environment of the protected area.</p> <p>Check that the detector is not in demo mode. This can be ascertained by viewing the event log and checking that the entry demo mode has a higher log entry number than the most recent FastLearn start and FastLearn end entries. Note: Remember that the log entries are in reverse order, with the most recent entries appearing first. If the log shows that demo mode was invoked during the last FastLearn period, start a new FastLearn and allow it to complete its 24-hour cycle.</p> <p>From the event log, check that 24 hours have elapsed since the last FastLearn end entry.</p> <p>Check that day-night switchover times are appropriately set to reflect active and nonactive periods.</p>
Elevated smoke levels do not generate alarms	<p>Check that detector is not isolated or in FastLearn (if Isolated, the Fault light will be lit; if in FastLearn, the OK light will flash).</p> <p>Check that the detector sampling points are in the smoke stream.</p> <p>Check that sampling pipes are firmly and cleanly seated in their ports and undamaged.</p> <p>Check that the correct ClassiFire alarm setting has been set.</p> <p>Check that the detector has either had a 24-hour learning period or that it has been placed in demo mode.</p>
Low mean output	<p>Check that the dust separator (filter) cartridge does not require changing (refer to Figure 19 on page 43 for details) and that the air plenum chamber is clean. The chamber may become clogged when, for example, heavy building activity has occurred near the sampling pipes. If so, the chamber may require factory service. The detector is not designed to handle large quantities of coarse debris and dust.</p>
Detector sensitivity varies over time	<p>There are many reasons why particle densities may vary, and the ClassiFire system is designed to automatically compensate for this in order to reduce the likelihood of nuisance alarms due to normal variations in background smoke density. Within limits set by the ClassiFire alarm factor, this is a normal part of the detector's operation.</p>

Problem	Solution/Corrective Action
Flow fault errors	<p>These occur when the airflow rate into the detector exceeds the preprogrammed parameters. As the detector “learns” the flow setup from the initial installation, this usually means that there has been some change in conditions. A Flow High fault may indicate that a sampling pipe is damaged, and a Flow Low fault may indicate that the pipe has been blocked, e.g., by nearby building operations.</p> <p>If the detector input is sampled from one area and the exhaust is in another area with different pressure (e.g., the detector is in a roof space and sampling from an enclosed room), this may lead to flow faults. In this case, it would be necessary to lead a pipe from the exhaust to the protected area to ensure nominal flow.</p>
“Low Flow” error message	<p>Check that the pipe is not blocked.</p> <p>If the pipe is unused, check that the flow sensor for this pipe has been disabled.</p> <p>Check that the low flow fault threshold is not set too high.</p> <p>In the case of intermittent fault indications, try increasing the flow fault delay time.</p>
“High Flow” error message	<p>Check that the pipe is seated in the inlet and is not broken or cracked.</p> <p>Check that installed pipework is fitted with endcaps. PipeCAD pipe modeling software prompts for the use of appropriate endcaps. Open bore pipes are not recommended.</p> <p>Check that the high flow fault threshold is not set too low.</p> <p>In the case of intermittent fault indications, try increasing the flow fault delay time.</p>

Chapter 5

Maintenance

Summary

This chapter provides scheduled and unscheduled maintenance procedures.

Content

Introduction 42

 Cleaning the detector 42

 Replacing the dust separator (filter) cartridge 42

Diagnostics 43

Introduction

This chapter contains maintenance instructions for the detection system. These procedures should be performed on a scheduled basis. In the event that system problems are found during routine maintenance, refer to Chapter 4 “Troubleshooting” on page 37. Failure to properly maintain the system may affect the functioning of the system.

Cleaning the detector

The exterior of the detector should be cleaned as necessary. Clean the detector with a damp (not wet) cloth.

Caution: Do not use solvents to clean the detector. Use of solvents may cause damage to the detector.

Replacing the dust separator (filter) cartridge

The only part that may require field replacement during servicing is the dust separator (filter) cartridge.* Its condition can be checked using the Dust Separator test in the Diagnostics menu of the remote configuration software or SenseNET software, which gives a percentage reading of dust separator (filter) efficiency. When this level drops to 80%, the detector will signal a Separator Renew fault indicating that the dust separator (filter) cartridge needs to be replaced.

For more information, refer to either the *Remote Configuration Software User Manual* or *SenseNET Software User Manual*.

*It is recommended that dust separators be changed at an interval of not more than 3 years. After replacing the filter, the detector must be put into FastLearn mode to reset the filter condition reading.

As dust contained in the dust separators may expose maintenance personnel to a ‘Nuisance Dust’ hazard as defined by the *Control of Substances Hazardous to Health* (COSHH), it is strongly recommended that suitable masks and protective clothing be worn when changing filters.

Note: Used dust separator (filter) cartridges are not intended for reuse and should be discarded.

.

To replace the cartridge:

1. Remove the six attachment screws which fasten the unit’s front cover.
2. With the front cover removed, grasp the filter firmly and pull the filter out (directly towards you).
3. Properly dispose of the used cartridge.

4. Insert the replacement filter cartridge such that the orientation of the “Direction of flow” arrow printed on the cartridge corresponds to the arrow on the “Direction of flow” label beside the filter slot.
5. Slide the cartridge all the way into place.
6. Replace the cover, and secure with all six fastening screws, and initiate a new FastLearn routine.

Figure 19: Location of dust separator (filter) cartridge

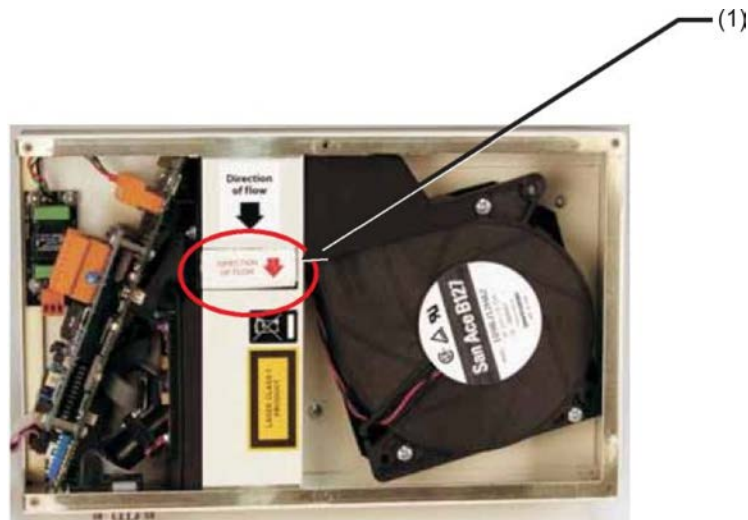

(1) Dust separator (filter) cartridge

Diagnostics

Both the remote configuration and SenseNET software packages include a diagnostic function which carries out a number of checks to verify the correct functioning of up to 127 detectors on a loop. These tests should be performed as part of a routine maintenance program.

A status bar will provide details about the tests being carried out. When the diagnostics are complete, the Status indicator for the selected detector in the main Diagnostics window of the software will either change from “Untested” to “OK” (if no problems are found) or will detail any fault found.

For more information, see the *Remote Configuration User Manual* or the *SenseNET Software User Manual*.

Index

A

- Addressing
 - Address table, 23
 - Setting the detector address, 22
- Advisory messages, 3
- Application, 10

C

- Commissioning, 34

D

- Detector components, 5
- Diagnostics, 43
- Docking station, 9

E

- Event log, 31

F

- Fire Alarm Panels
 - Interfacing, 20

I

- Installation, 9
 - Electrical, 16
 - Mechanical, 16

M

- Maintenance
 - Cleaning the detector, 42
 - Replacing the dust separator (filter), 42

P

- Power supply connections, 17
- Programmable functions, 28

R

- Relays, 20

S

- SenseNET
 - Connecting, 25
- signal connections, 18
- Software
 - available software, 2
- Specifications, 3
- System design, 11

T

- Terminal blocks, 6

