



**ZAPI**<sup>®</sup> S.p.A.

**ELECTRONIC • OLEODYNAMIC • INDUSTRIAL  
EQUIPMENTS CONSTRUCTION**

Via Parma, 59 – 42028 – POVIGLIO (RE) – ITALY  
Tel +39 0522 960050 (r.a.) – Fax +39 0522 960259  
e-mail: [zapi@zapispa.it](mailto:zapi@zapispa.it) – web: [www.zapispa.it](http://www.zapispa.it)

EN

*User Manual*

# COMBIACX & ACEX

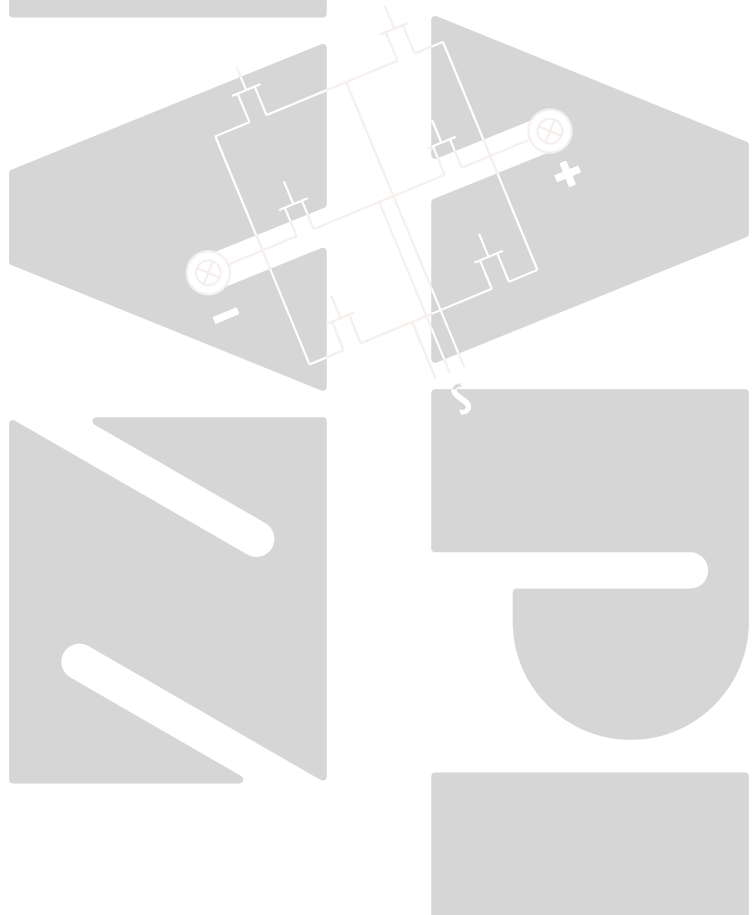

The contents of this publication is a ZAPI S.p.A. property; all related authorizations are covered by Copyright. Any partial or total reproduction is prohibited.

Under no circumstances will Zapi S.p.A. be held responsible to third parties for damage caused by the improper use of the present publication and of the device/devices described in it.

Zapi spa reserves the right to make changes or improvements to its products at any time and without notice.

The present publication reflects the characteristics of the product described at the moment of distribution. The publication therefore does not reflect any changes in the characteristics of the product as a result of updating.



**ZAPI**® is a registered trademark property of Zapi S.p.A.

## NOTES LEGEND



*The symbol aboard is used inside this publication to indicate an annotation or a suggestion you should pay attention.*

---



***The symbol aboard is used inside this publication to indicate an action or a characteristic very important as for security. Pay special attention to the annotations pointed out with this symbol.***

---

# Contents

<b>1</b>	<b>INTRODUCTION .....</b>	<b>5</b>
<b>2</b>	<b>SPECIFICATION .....</b>	<b>6</b>
2.1	Technical specifications COMBIACX / ACEX.....	6
2.2	Technical specifications COMBIACX Power / ACEX Power .....	6
2.3	Block diagrams .....	7
2.3.1	Traction control.....	7
2.3.2	Pump control .....	7
<b>3</b>	<b>SPECIFICATION FOR THE INPUT DEVICES FILLING UP THE INSTALLATION KIT .....</b>	<b>8</b>
3.1	Digital inputs .....	8
3.1.1	DI0 ÷ DI10 technical details – 24 V system .....	8
3.1.2	DI0 ÷ DI10 technical details – 36/48 V system .....	8
3.1.3	Microswitches .....	8
3.2	Analog unit .....	8
3.3	Other analogue control unit .....	9
3.4	Analog motor thermal sensor input.....	9
3.5	Speed feedback .....	10
<b>4</b>	<b>INSTALLATION HINTS .....</b>	<b>11</b>
4.1	Material overview .....	11
4.1.1	Connection cables .....	11
4.1.2	Contactors .....	11
4.1.3	Fuses.....	12
4.2	Installation of the hardware .....	12
4.2.1	Positioning and cooling of the controller.....	12
4.2.2	Wirings: power cables .....	12
4.2.3	Wirings: CAN connections and possible interferences .....	13
4.2.4	Wirings: I/O connections.....	15
4.2.5	Connection of the encoder .....	16
4.2.6	Main contactor and key connection .....	17
4.2.7	Insulation of truck frame .....	17
4.3	Protection and safety features.....	18
4.3.1	Protection features .....	18
4.3.2	Safety Features .....	19
4.4	EMC .....	19
4.5	Various suggestions .....	21
<b>5</b>	<b>OPERATIONAL FEATURES .....</b>	<b>22</b>
5.1	Diagnosis.....	22
<b>6</b>	<b>DESCRIPTION OF THE CONNECTORS .....</b>	<b>23</b>
6.1	Connectors of the logic.....	23
6.1.1	CNA external connector .....	23
6.1.2	CNB external connector .....	24
6.1.3	CNC external connector .....	24
6.1.4	CND external connector .....	25
6.1.5	CNE internal connector .....	25
<b>7</b>	<b>DESCRIPTION OF POWER CONNECTIONS.....</b>	<b>26</b>
<b>8</b>	<b>DRAWINGS.....</b>	<b>27</b>
8.1	Mechanical drawing COMBIACX.....	27
8.2	Mechanical drawing ACEX.....	28

8.3	Connection drawing COMBIACX.....	29
8.4	Connection drawing ACEX.....	30
<b>9</b>	<b>ONE SHOT INSTALLATION PROCEDURE .....</b>	<b>31</b>
9.1	Sequence for Ac Inverter traction setting .....	32
<b>10</b>	<b>PROGRAMMING &amp; ADJUSTMENTS USING DIGITAL CONSOLE .....</b>	<b>34</b>
10.1	Adjustments via console.....	34
10.2	Description of console (hand set) & connection .....	34
10.3	Description of the console menu .....	35
10.3.1	COMBIACX / ACEX Menu.....	35
10.4	Function configuration .....	36
10.4.1	Config menu "SET OPTIONS" functions list.....	36
10.4.2	Config menu "ADJUSTMENTS" functions list .....	39
10.4.3	Main menu "PARAMETER CHANGE" functions list.....	43
10.4.4	Zapi menu "SPECIAL ADJUSTMENTS" functions list.....	49
10.4.5	Main menu "TESTER" functions list .....	50
<b>11</b>	<b>OTHER FUNCTIONS .....</b>	<b>54</b>
11.1	Description of console "SAVE" function .....	54
11.2	Description of console "RESTORE" function.....	55
11.3	Description of console "PROGRAM VACC" function.....	56
11.4	Description of the throttle regulation.....	58
11.5	Description of the battery charge detection setting .....	59
<b>12</b>	<b>COMBIACX /ACEX ALARMS LIST .....</b>	<b>61</b>
12.1	Faults diagnostic system .....	61
12.2	Alarms overview .....	62
12.3	Warnings overview .....	72
12.4	Analysis and troubleshooting of warnings .....	74
<b>13</b>	<b>RECOMMENDED SPARE PARTS .....</b>	<b>80</b>
<b>14</b>	<b>PERIODIC MAINTENANCE TO BE REPEATED AT TIMES INDICATED.....</b>	<b>81</b>

### APPROVAL SIGNS

COMPANY FUNCTION	INIZIALS	SIGN
PROJECT MANAGER		
TECHNICAL ELECTRONIC MANAGER VISA		
SALES MANAGER VISA		

Publication N°: **AFCZP0BB**  
Edition: **November 2010**

# 1 INTRODUCTION

The COMBIACX / ACEX inverter has been developed to perform all the electric functions that are usually presents in walkie and rider pallet trucks, stackers, low level order pickers.

The controller can perform the following functions:

- Controller for AC 600W to 2 kW AC motors;
- Pump controller for series wounded DC motors up to 5 kW (only for COMBIACX).
- Driver for Line Contactor coil
- Drivers for ON/OFF electrovalves and for one proportional valve (electro-distributor)
- Low side and high side (short circuit protected) drives for electric brake coil
- Canbus interface
- Interface for Canbus tiller
- Zapi patented sensorless and sense coil control
- 192 kBytes Flash memory embedded.
- Software downloadable via Serial link (internal connectors) or Canbus (external connector)
- ESD protection on Canbus inputs CANL and CANH

## 2 SPECIFICATION

### 2.1 Technical specifications COMBIACX / ACEX

Inverter for traction AC asynchronous 3-phase motors plus chopper for DC series pump motors.  
Regenerative braking functions.  
Digital control based upon microcontroller

Voltage:	24, 36, 48V
Inverter maximum current (24V):	165A (RMS) for 2'
Continuous output current (24V):	70A (RMS) continuous
Inverter maximum current (36/48V):	140 (RMS) for 2'
Continuous output current (36/48V):	60A (RMS) continuous
Inverter operating frequency:	8kHz
Dc chopper Maximum current (24V)(1):	280A for 2'
Dc chopper Maximum current (36V/48V)(1):	240A for 2'
Chopper Operating frequency(1):	16kHz
External temperature working range:	-40°C ÷ 40°C
Maximum heatsink temperature (start of the thermal cutback):	85°C



*Note(1): The DC chopper specifications are related to COMBIACX only*

### 2.2 Technical specifications COMBIACX Power / ACEX Power

Inverter for traction AC asynchronous 3-phase motors plus chopper for DC series pump motors.  
Regenerative braking functions.  
Digital control based upon microcontroller

Voltage:	24, 36, 48V
Inverter maximum current (24V):	240A (RMS) for 2'
Continuous output current (24V):	90A (RMS) continuous
Inverter maximum current (36V/48V):	210A (RMS) for 2'
Continuous output current (36V/48V):	80A (RMS) continuous
Inverter operating frequency:	8kHz
Dc chopper Maximum current (24V)(1):	280A for 2'
Dc chopper Maximum current (36V/48V)(1):	240A for 2'
Chopper Operating frequency(1):	16kHz
External temperature working range:	-40°C ÷ 40°C
Maximum heatsink temperature (start of the thermal cutback):	85°C



*Note(1): The DC chopper specifications are related to COMBIACX only*

## 2.3 Block diagrams

### 2.3.1 Traction control

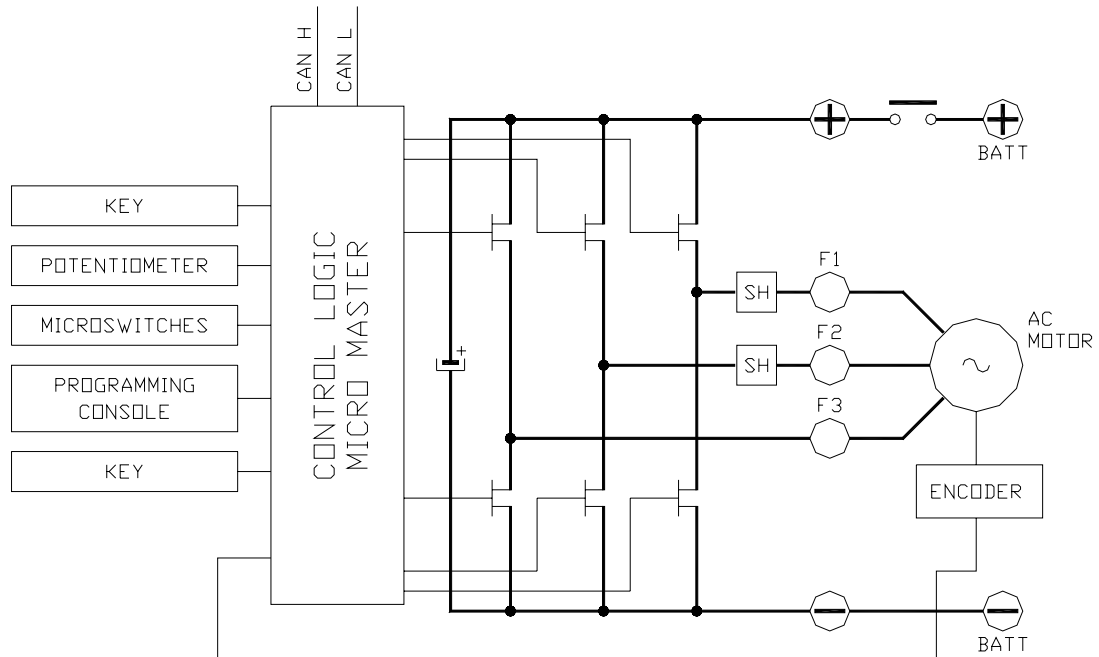

### 2.3.2 Pump control

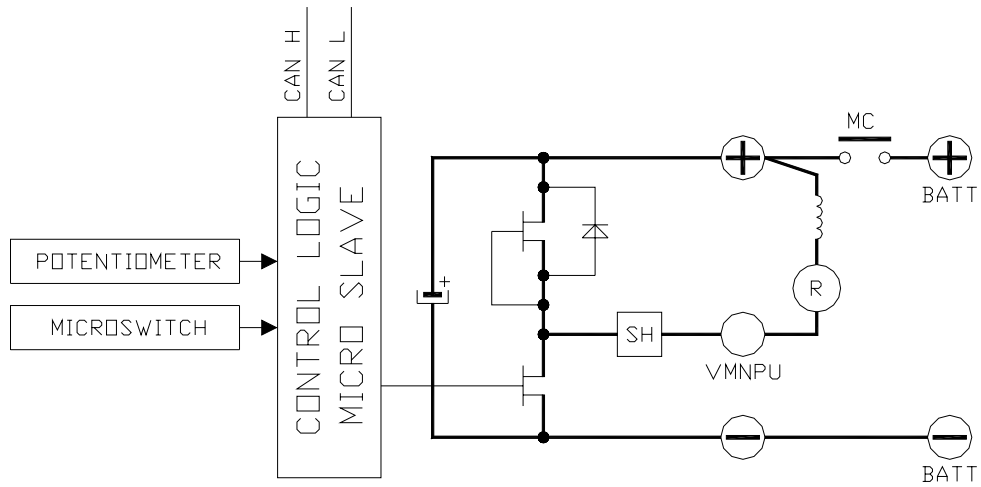

# 3 SPECIFICATION FOR THE INPUT DEVICES FILLING UP THE INSTALLATION KIT

## 3.1 Digital inputs

COMBIACX / ACEX digital inputs work in the voltage range [-Batt; +Batt]. Related command devices (microswitches) must be connected to +BATT (typically to key voltage).

Pull-down resistance to -Batt is built-in.

Functional devices (like FW, BACK, LIFT, DESCENT, HORN, H&S, TILLER, BELLY switches) are Normally Open; so related function becomes active when the microswitch closes.

Safety devices (like CUTBACK switches) are Normally Closed; so related function becomes active when the microswitch opens.

The DI11 and DI12, which are not available in the Sense Coil version, are activated closing the external microswitch to -Batt.

### 3.1.1 DI0 ÷ DI10 technical details – 24 V system

- Switching threshold: 4V [ $\pm 0,5V$ ]
- Input impedance: 4,5kOhm [ $\pm 0,5kOhm$ ]

### 3.1.2 DI0 ÷ DI10 technical details – 36/48 V system

- Switching threshold: 4,2V [ $\pm 0,5V$ ]
- Input impedance: 13,5kOhm [ $\pm 1kOhm$ ]

### 3.1.3 Microswitches

- It is suggested that microswitches have a contact resistance lower than 0,1Ohm and a leakage current lower than 100 $\mu A$ .
- When full load connected, the voltage between the key switch contacts must be lower than 0.1V.
- If the microswitch to be used has different characteristic, it is suggested to discuss them and their application with Zapi technicians.

## 3.2 Analog unit

The analog input can be connected to an accelerator unit if the Zapi CAN or serial tiller is not used.

The accelerator unit can consist of a potentiometer or an Hall effect device.

It should be in a 3-wire configuration. The potentiometer is supplied through CNC#8. Potentiometer output signal must be input to CPOT1 (CNC#4) signal range is from 0 to 10V.

The negative supply of the potentiometer has to be taken from NPOT (CNC#3).

Potentiometer value should be in the 0.5 - 10 kOhm range; generally, the load should be in the 1.5mA to 30mA range. Faults can occur if it is outside this range.

The standard connection for the potentiometer is the one in the Left side of next figure (potentiometer on one end at rest) in combination with a couple of Travel demand switches. On request it is also possible the handling in the Right side of next figure (potentiometer in the middle at rest) still in combination with a couple of



Travel demand switches.

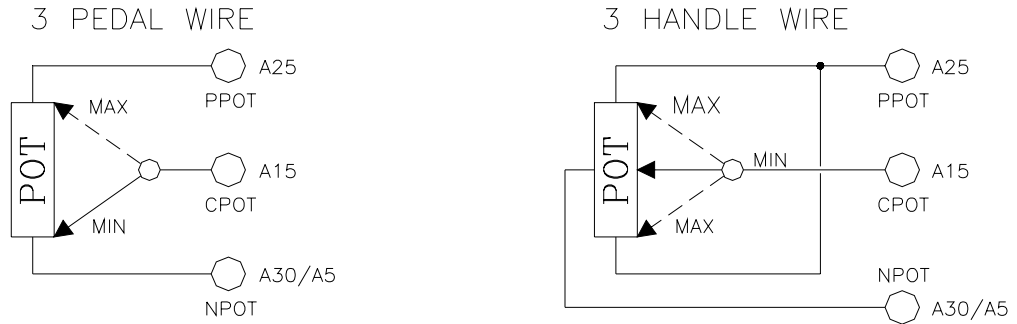

The Procedure for automatic potentiometer signal acquisition is carried out using the Hand Set. This enables adjustment of the minimum and maximum useful signal level, in either direction.

### 3.3 Other analogue control unit

If the Zapi can tiller is not used, input CNC#9 can be used as analogue input, whose typical application is a proportional command to enable a lifting/lowering function. It is possible to use this input for an alternative function like a proportional braking.

It should be in a 3 wire configuration. Potentiometer value should be in the 0.5-10 kOhm range. Generally, the load should be in the 1.5mA to 30 mA range.

The CPOTL (CNA#9) signal range is from 0 to 10V.

Use CNC#8 (positive) and CNA#3 (negative) to supply it.

### 3.4 Analog motor thermal sensor input

Input CND#3 is an analogue input to receive an analogue thermal sensor signal to measure the Traction Motor Winding Temperature. The analogue device installed in the motor has to be specified, in order to insert the correct look-up table in the software. A digital device can also be used.

---

## 3.5 Speed feedback

The motor control is based upon the motor speed feedback (sensored software). The speed transducer is an incremental encoder, with two phases shifted at 90°.

The encoder can be of different types :

- power supply: +12V / +5V;
- electric output: open collector ( NPN ), push-pull.

COMBIACX / ACEX can also operate without encoder, this using a sensorless control.

This solution has to be discussed with Zapi technicians.



*Note (1): The encoder resolution and the motor poles pair (the controller can handle), is specified in the home page display of the handset showing following headline:*

*ADXZ2A                      ZP1.00*

*That means:*

*ADXZ= COMBIACX Zapi controller*

*2 = motor's poles pair number*

*A = 32 pulses/rev encoder*

*The encoder resolution is given by the second-last letter in the following list:*

*A = 32 pulses/rev*

*K = 48 pulses/rev*

*B = 64 pulses/rev*

*C = 80 pulses/rev*

---

# 4 INSTALLATION HINTS

In the description of these installation suggestions you will find some boxes of different colours, they mean:



These are **informations** useful for anyone is working on the installation, or a deeper examination of the content

---



These are **Warning boxes**, they describe:

- operations that can lead to a failure of the electronic device or can be dangerous or harmful for the operator;
- items which are important to guarantee system performance and safety

---

## 4.1 Material overview

Before starting it is necessary to have the required material for a correct installation. Otherwise a wrong choice of cables or other parts could lead to failures/ misbehaviour/ bad performances.

### 4.1.1 Connection cables

For the auxiliary circuits, use cables 0.5mm<sup>2</sup> section at least.

For power connections to the motor and to the battery, use cables having a minimum section of 15 mm<sup>2</sup>.

For the optimum inverter performance, the cables to the battery should be run side by side and be as short as possible.

### 4.1.2 Contactors

IT IS STRONGLY RECCOMENDED TO USE A MAIN CONTACTOR to connect and cut off the battery to the controller. Depending on the setting of a parameter in the controller:

- the output which drives the main contactor coil is on/off (the coil is driven with the full battery voltage).
- the output which drives the main contactor coil is switched at high frequency (1 kHz) with a programmable duty cycle; this feature is useful to decrease the power dissipation of the contactor coil.



**The EN1175 states the main Contactor is not mandatory (under proper conditions); anyway it is recommended to protect the inverter against reverse battery polarity and to cut off the battery from the power mosfets when a failure in the three phase bridge occurs.**

---

### 4.1.3 Fuses

- Use a 6.3-10A Fuse for protection of the auxiliary circuits.
- For protection of the power unit, refer to chapter 13 (Recommended spare parts for inverter). The Fuse value shown is the maximum allowable. For special applications or requirements these values can be reduced.
- For Safety reasons, we recommend the use of protected fuses in order to prevent the spread of fused particles should the fuse blow.

---

## 4.2 Installation of the hardware

---



***Before doing any operation, ensure that the battery is disconnected and when all the installation is completed start the machine with the drive wheels raised from the floor to ensure that any installation error do not compromise safety. After operation, even with the Key Switch open, the internal capacitors may remain charged for some time. For safe operation, we recommend that the battery is disconnected, and a short circuit is made between Battery Positive and Battery Negative power terminals of the chopper using a Resistor between 10 Ohm and 100 Ohm. Minimum 5 Watts.***

---

### 4.2.1 Positioning and cooling of the controller

**CONTROLLER WITH BASE PLATE:** Install the controller with the base-plate on a flat metallic surface that is clean and unpainted; suggested characteristics are: planarity 0.05 mm and rugosity 1.6  $\mu\text{m}$

- Apply a light layer of thermo-conductive grease between the two surfaces to permit better heat dissipation.
- The heat generated by the power block must be dissipated. For this to be possible, the compartment must be ventilated and the heat sink materials ample.
- The heat sink material and system should be sized on the performance requirement of the machine. Abnormal ambient air temperatures should be considered. In situations where either ventilation is poor, or heat exchange is difficult, forced air ventilation should be used.
- The thermal energy dissipated by the power block module varies and is dependent on the current drawn and the duty cycle.

**CONTROLLER WITH FINNED HEATSINK:** Sometimes the base plate installation cannot be adopted. Due to positioning problems or to the lack of a thick enough truck frame, it is necessary to adopt a finned dissipation combined with one or more fans.

- The air flux should hit the fins directly, to maximize the cooling effect.
- In addition to fans, also air ducting systems can be used to maintain low the temperature of the controller.
- It is necessary to ensure that cold air is taken from outside the controller compartment and hot air is easily pushed away from the controller compartment.
- It is mandatory to avoid that the cooling air is recirculated inside the controller compartment.

### 4.2.2 Wirings: power cables

- The power cables length must be as short as possible to minimize power losses.

- They must be tightened on controller power posts with a Torque of  $7 \pm 1.4$  Nm
- The COMBIACX module should only be connected to a traction battery. Do not use converters outputs or power supplies. For special applications please contact the nearest Zapi Service Centre.



**Do not connect the controller to a battery with a nominal voltage different than the value indicated on the controller label. A higher battery voltage may cause MOS failure. A lower voltage may prevent the logic operating.**

### 4.2.3 Wirings: CAN connections and possible interferences



*CAN Stands for Controller Area Network. It is a communication protocol for real time control applications. CAN operates at data rate of up to 1 Megabits per second. It was invented by the German company Bosch to be used in the car industry to permit communication among the various electronic modules of a vehicle, connected as illustrated in this image:*

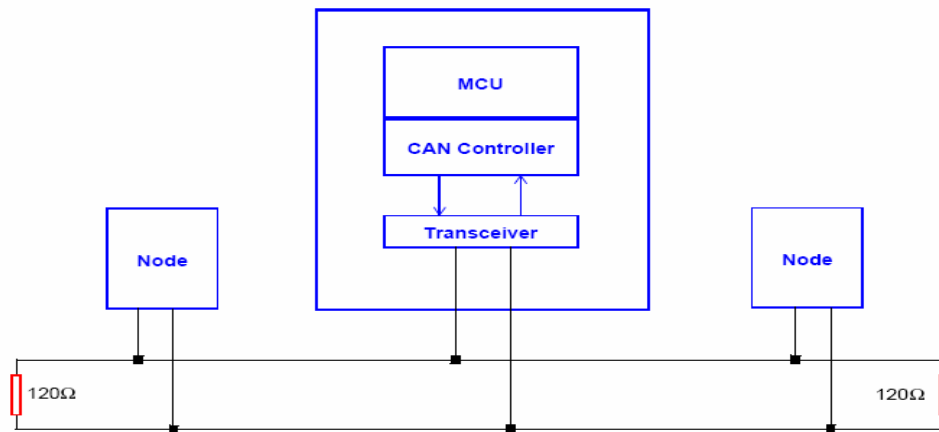

- The best cable for can connections is the twisted pair; if it is necessary to increase the immunity of the system to disturbances, a good choice would be to use a cable with a shield connected to the frame of the truck. Sometimes it is sufficient a simple double wire cable or a duplex cable not shielded.
- In a system like an industrial truck, where power cables carry hundreds of Ampere, there are voltage drops due to the impedance of the cables, and that could cause errors on the data transmitted through the can wires. In the following figures there is an overview of wrong and right layouts of the cables routing.



### **Wrong Layout:**

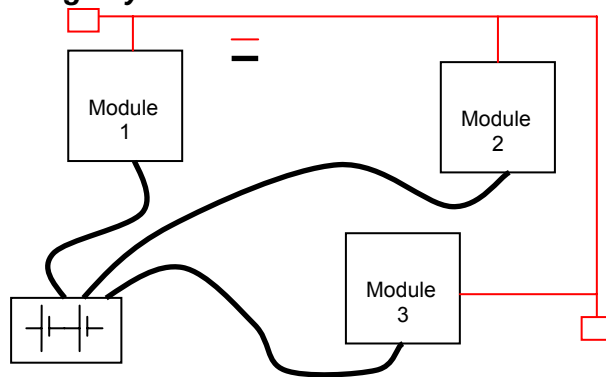

The red lines are can wires.  
The black boxes are different modules, for example traction controller, pump controller and display connected by Canbus.  
The black lines are the power cables.

This is apparently a good layout, but can bring to errors in the can line.  
The best solution depends on the type of nodes (modules) connected in the network.  
If the modules are very different in terms of power, then the preferable connection is the daisy chain.



### **Correct Layout:**

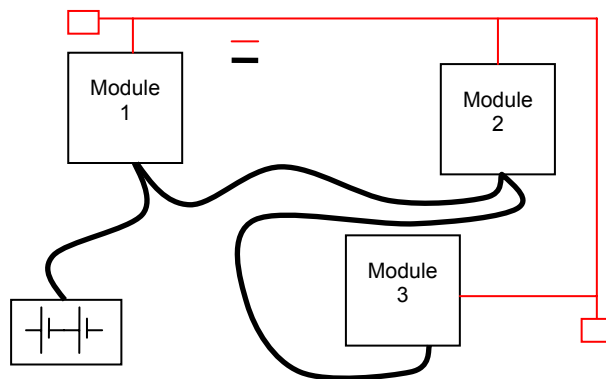

**Note: Module 1 power > Module 2 power > Module 3 power**

The chain starts from the –BATT post of the controller that works with the highest current, and the others are connected in a decreasing order of power.

Otherwise, if two controllers are similar in power (for example a traction and a pump motor controller) and a third module works with less current, the best way to deal this configuration is to create a common ground point (star configuration)



### Correct Layout:

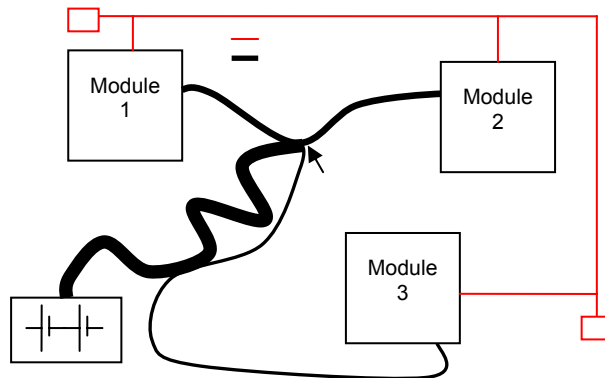

**Note: Module 1 power  $\approx$  Module 2 power  $>$  Module 3 power**

---

In this case the power cables starting from the two similar controllers must be as short as possible. Of course also the diameter of the cable concurs in the voltage drops described before (higher diameter means lower impedance), so in this last example the cable between the minus of the Battery and the common ground point (pointed by the arrow in the image) must be dimensioned taking into account thermal and voltage drop problems.



#### Can advantages

*The complexity of today systems needs more and more data, signal and information must flow from a node to another. CAN is the solution to different problems that arise from this complexity*

- *simplified design (readily available, multi sourced components and tools)*
- *lower costs (less and smaller cables )*
- *improved reliability (fewer connections)*
- *analysis of problems improved (easy connection with a pc to read the data flowing through the cable)*

---

#### 4.2.4 Wirings: I/O connections

- After crimping the cable, verify that all strands are entrapped in the wire barrel.
- Verify that all the crimped contacts are completely inserted on the connector cavities



***A cable connected to the wrong pin can lead to short circuits and failure; so, before turning on the truck for the first time, verify with a multimeter the continuity between the starting point and the end of a signal wire***

- for information about the mating connector pin assignment see the paragraph “description of the connectors”

## 4.2.5 Connection of the encoder

- 1) COMBIACX/ ACEX card is fit for different types of encoder. To control an AC motor with the Zapi inverter, it is necessary to install an incremental encoder with 2 phases shifted of 90°. The encoder power supply can be +5V or +12V. It can have different electronic output.

D2	+5V / +12V	positive of encoder power supply.
D5	GND	negative of encoder power supply.
D1	A	phase A of encoder.
D4	B	phase B of encoder.

- 2) Connection of encoder with open collector output; +5V and +12V power supply.

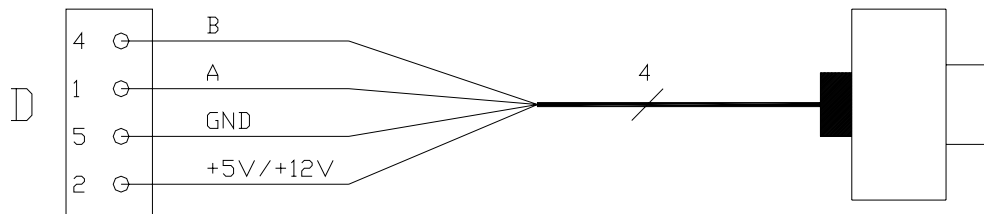

### **VERY IMPORTANT**

***It is necessary to specify in the order the type of encoder used, in terms of power supply, electronic output and n° of pulses for revolution, because the logic unit must be set in the correct way by Zapi.***

***The n° of pulses revolution the controller can handle is given by the second-last letter in the software release name (see 3.5).***

---



## 4.2.6 Main contactor and key connection

- The connection of the main contactor can be carried out following the drawing in the figure.

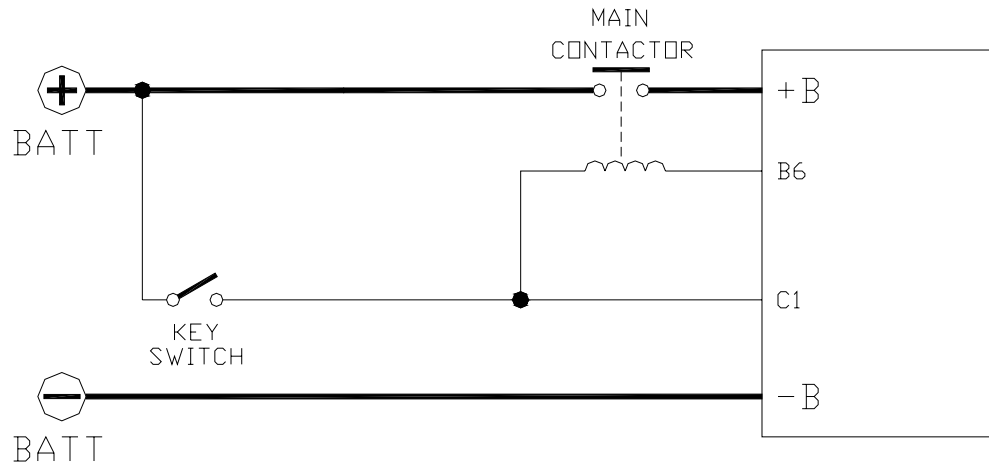

- The connection of the battery line switches must be carried out following ZAPI instructions.
- If a mechanical battery line switch is installed, it is strongly recommended that the key supply to the inverter is open together with power battery line (see picture below); if not, the inverter may be damaged if the switch is opened during a regenerative braking.
- An intrinsic protection is present inside the logic when the voltage on the battery power connection overtakes 40% more than the battery nominal voltage or if the key is switched off before the battery power line is disconnected.

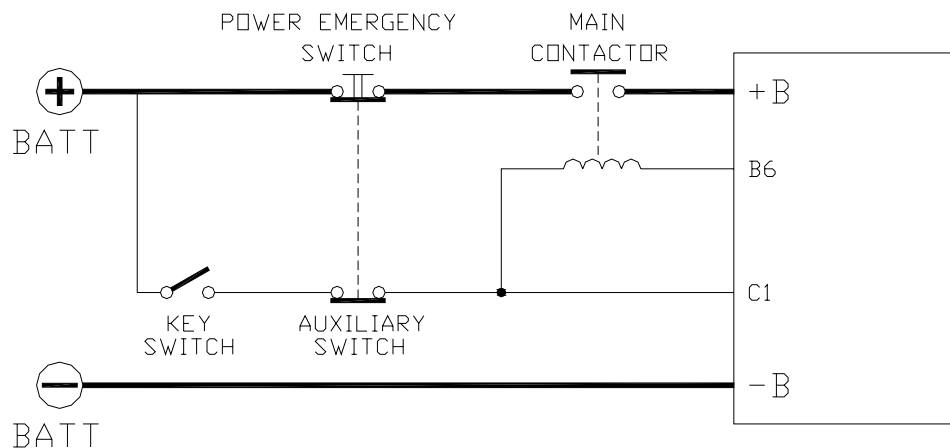

## 4.2.7 Insulation of truck frame



**As stated by EN-1175 “Safety of machinery – Industrial truck”, chapter 5.7, “there shall be no electrical connection to the truck frame”. So the truck frame has to be isolated from any electrical potential of the truck power line.**

## 4.3 Protection and safety features

### 4.3.1 Protection features

The COMBIACX / ACEX is protected against some controller injuries and malfunctions:

- **Battery polarity inversion**

It is necessary to fit a LINE CONTACTOR to protect the controller against reverse battery polarity and for safety reasons.

- **Connection Errors**

All inputs are protected against connection errors.

- **Thermal protection**

If the controller temperature exceeds 85°C, the maximum current is reduced in proportion to the thermal increase. The temperature can never exceeds 105°C.

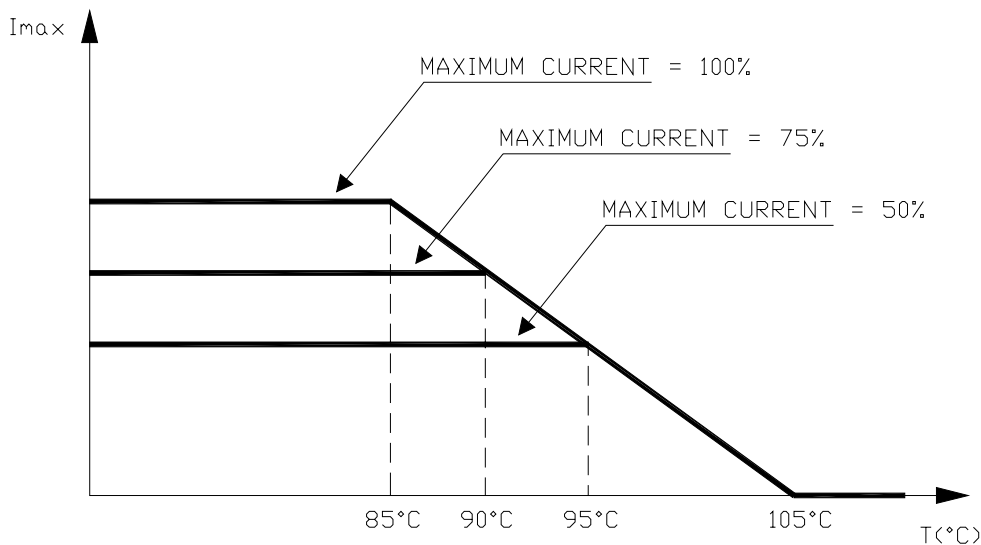

- **External agents**

The inverter is protected against dust and the spray of liquid to a degree of protection meeting IP65. Nevertheless, it is suggested to carefully study controller installation and position. With few simple shrewdness, the degree of controller protection can be strongly increased.

- **Protection against uncontrolled movements**

The main contactor will not close if:

- The Power unit is not functioning.
- The Logic or Canbus interface is not functioning perfectly.
- The Can Tiller is not operating correctly.
- Running microswitches are in open position.

- **Low battery charge**

when the battery charge is low, the maximum current is reduced to the half of the maximum current programmed; additionally an alarm message is displayed.

- **Protection against accidental Start up**

A precise sequence of operations are necessary before the machine will start. Operation cannot begin if these operations are not carried out correctly. Requests for drive must be made after closing the key switch.

### 4.3.2 Safety Features

---



**ZAPI controllers are designed according to the EN13849-1 specifications for safety related parts of control system and to UNI EN1175-1 norm. The safety of the machine is strongly related to installation; length, layout and screening of electrical connections have to be carefully designed.**

**ZAPI is always available to cooperate with the customer in order to evaluate installation and connection solutions. Furthermore, ZAPI is available to develop new SW or HW solutions to improve the safety of the machine, according to customer requirements.**

**Machine manufacturer holds the responsibility for the truck safety features and related approval.**

---

## 4.4 EMC

---



**EMC and ESD performances of an electronic system are strongly influenced by the installation. Special attention must be given to the lengths and the paths of the electric connections and the shields. This situation is beyond ZAPI's control. Zapi can offer assistance and suggestions, based on its years experience, on EMC related items. However, ZAPI declines any responsibility for non-compliance, malfunctions and failures, if correct testing is not made. The machine manufacturer holds the responsibility to carry out machine validation, based on existing norms (EN12895 for industrial truck; EN50081-2 for other applications).**

---

EMC stands for Electromagnetic Compatibility, and it represents the studies and the tests on the electromagnetic energy generated or received by an electrical device. So the analysis works in two directions:

- 1) The study of the **emission** problems, the disturbances generated by the device and the possible countermeasure to prevent the propagation of that energy; we talk about “conduction” issues when guiding structures such wires and cables are involved, “radiated emissions” issues when it is studied the propagation of electromagnetic energy through the open space. In our case the origin of the disturbances can be found inside the controller with the switching of the mosfets which are working at high frequency and generate RF energy, **but wires and cables have the key role to propagate the disturbs because they works as antennas**, so a good layout of the cables and their shielding can solve the majority of the emission problems.
- 2) The study of the **immunity** can be divided in two main branches: protection from electromagnetic fields and from electrostatic discharge.  
The **electromagnetic immunity** concern the susceptibility of the controller with regard to electromagnetic fields and their influence on the correct work made by the electronic device.  
There are well defined tests which the machine has to be exposed to.  
These tests are carried out at determined levels of electromagnetic fields, to

simulate external undesired disturbances and verify the electronic devices response.

- 3) The second type of immunity, **ESD**, concerns the prevention of the effects of electric current due to excessive electric charge stored in an object. In fact, when a charge is created on a material and it remains there, it becomes an “electrostatic charge”; ESD happen when there is a rapid transfer from a charged object to another. This rapid transfer has, in turn, two important effects:
  - this rapid charge transfer can determine, by induction, disturbs on the signal wiring and thus create malfunctions; this effect is particularly critical in modern machines, with serial communications (canbus) which are spread everywhere on the truck and which carry critical informations.
  - in the worst case and when the amount of charge is very high, the discharge process can determine failures in the electronic devices; the type of failure can vary from an intermittently malfunction to a completely failure of the electronic device.



**IMPORTANT NOTE: it is always much easier and cheaper to avoid ESD from being generated, than to increase the level of immunity of the electronic devices.**

---

There are different solutions for EMC issues, depending on level of emissions/immunity required, the type of controller, materials and position of the wires and electronic components.

- 4) **EMISSIONS.** Three ways can be followed to reduce the emissions:
  - A) **SOURCE OF EMISSIONS:** finding the main source of disturb and work on it.
  - B) **SHIELDING:** enclosing contactor and controller in a shielded box; using shielded cables;
  - C) **LAYOUT:** a good layout of the cables can minimize the antenna effect; cables running nearby the truck frame or in iron channels connected to truck frames is generally a suggested not expensive solution to reduce the emission level.
- 5) **ELECTROMAGNETIC IMMUNITY.** The considerations made for emissions are valid also for immunity. Additionally, further protection can be achieved with ferrite beads and bypass capacitors.
- 6) **ELECTROSTATIC IMMUNITY.** Three ways can be followed to prevent damages from ESD:
  - A) **PREVENTION:** when handling ESD-sensitive electronic parts, ensure the operator is grounded; test grounding devices on a daily basis for correct functioning; this precaution is particularly important during controller handling in the storing and installation phase.
  - B) **ISOLATION:** use anti-static containers when transferring ESD-sensitive material.
  - C) **GROUNDING:** when a complete isolation cannot be achieved, a good grounding can divert the discharge current trough a “safe” path; the frame of a truck can works like a “local earth ground”, absorbing excess charge. **So it**

**is strongly suggested to connect to truck frame all the parts of the truck which can be touched by the operator, who is most of the time the source of ESD.**

---

## **4.5 Various suggestions**

Never combine SCR low frequency choppers with COMBIACX / ACEX modules. The filter capacitors contained in the COMBIACX / ACEX module would change the SCR chopper operation and subject to excessive workload. If it is necessary to use two or more control units, like the chopper should be of the Zapimos family.

During battery recharge, the COMBIACX / ACEX must be completely disconnected from the battery. Beside changing the charging current seen by the battery charger, the module can be damaged by higher than normal voltages supplied via the charger.

# 5 OPERATIONAL FEATURES

- Speed control.
- Optimum behaviour on a slope if the speed feedback is used:
  1. The motor speed follows the accelerator, starting a regenerative braking if the speed overtakes the speed set-point
  2. The system can perform an electrical stop on a ramp (the machine is electrically hold on a slope) for a programmable time (if encoder is used)
- Stable speed in every position of the accelerator.
- Regenerative release braking based upon deceleration ramps.
- Regenerative braking when the accelerator pedal is partially released (deceleration).
- Direction inversion with regenerative braking based upon deceleration ramp.
- Regenerative braking and direction inversion without contactors: only the main contactor is present.
- The release braking ramp can be modulated by an analogue input, so that a proportional brake feature is obtained.
- Optimum sensitivity at low speeds.
- Voltage boost at the start and with overload to obtain more torque (with current control).
- The inverter can drive an electromechanical brake.
- High efficiency of motor and battery due to high frequency commutations.
- Modification of parameters through the programming console.
- Internal hour-meter with values that can be displayed on the console.
- Memory of the last five alarms with relative hour-meter and temperature displayed on the console.
- Test function within console for checking main parameters.
- Direct communication between traction AC inverter and pump DC chopper.

---

## 5.1 Diagnosis

The microcontrollers continually monitor the inverter and the chopper and carry out diagnostic procedures on the main functions.

The diagnosis is made in 4 points:

- 1) Diagnosis at start-up that checks: watch-dog, Current Sensors, Capacitor charging, phase's voltages, pump motor output, contactor drivers, can-bus interface, presence of a start requirement, connection with the Can Tiller.
- 2) Standby Diagnosis that checks: watch-dog, phase's voltages, pump motor output, Contactor Drivers, Current Sensors, can-bus interface.
- 3) Driving diagnosis that checks: Watchdog, Current sensors, Contactor(s), can-bus interface.
- 4) Continuous Diagnosis that checks: power stage temperature, motor temperature, Battery Voltage.

Error codes are provided in two ways. The digital console can be used, which gives a detailed information about the failure; the failure code is also sent on the Can-Bus.

# 6 DESCRIPTION OF THE CONNECTORS

## 6.1 Connectors of the logic

The COMBIACX / ACEX inverter use four Molex Minifit connectors

### 6.1.1 CNA external connector

A1	EV1	Output of the protected ON/OFF electrovalve driver; 1,5 A maximum continuous current (driving to –Batt). Built-in freewheeling diode to B2. This output is activated when the 1ST function (input A12) is request.
A2	EV3	Output of the protected ON/OFF electrovalve driver; 1,5 A maximum continuous current (driving to –Batt). Built-in freewheeling diode to B2. This output is activated when the LIFT function (input A5) is request.
A3	NAUX2	Auxiliary output. Internal 330R resistance in series to the driver (driving to –Batt). Max continuous current: 35mA. Typical function: to drive a led. If the BATTERY CHECK option is different than zero, this output blinks with a 1 sec. period when the calculated battery charge is between 10% and 30%, and it stays on when the calculated battery charge is $\leq 10\%$ .
A4	DI5	Input of the switch DI5. The input is activated when it is connected to +Batt. The default function is the controller “HORN” input, closing the switch the horn output is activated.
A5	DI7	Input of the switch DI7. The input is activated when it is connected to +Batt. The default function is the controller “LIFT” enable input.
A6	DI9	Input of the switch DI9. The input is activated when the external switch is opened. The default function is the controller “PUMP CUTBACK” input, opening the switch pump speed is reduced.
A7	DI11	Input of the switch DI11. The input is activated when the external switch is opened to ground. The default function is the controller “CUTBACK1” input, opening the switch truck speed is reduced. In the Sense Coil version this input is connected to the AC motor sense coil.
A8	EV2	Output of the protected ON/OFF electrovalve driver; 1,5 A maximum continuous current (driving to –Batt). Built-in freewheeling diode to B2. This output is activated when the 2ND function (input A13) is request.
A9	NAUX1	Auxiliary output. Internal 330R resistance in series to the driver (driving to –Batt). Max continuous current: 35mA. Typical function: to drive a led. This output blinks with a 1 sec. period when a warning is displayed by the controller. It also blinks with a 0.5 sec. period when an alarm is displayed when no alarm are displayed, this output is OFF.

A10	GND	This is the ground of the logic board.
A11	DI6	Input of the switch DI6. The input is activated when it is connected to +Batt. The default function is the controller “ <b>LOWER</b> ” enable input.
A12	DI8	Input of the switch DI8. The input is activated when it is connected to +Batt. The default function is the controller “ <b>1ST</b> ” input: the pump motor turn at a defined speed.
A13	DI10	Input of the switch DI10. The input is activated when it is connected to +Batt. The default function is the controller “ <b>2ND</b> ” input: the pump motor turn at a defined speed.
A14	DI12	Input of the switch DI12. The input is activated when the external switch is opened to ground. The default function is the controller “ <b>CUTBACK2</b> ” input, opening the switch truck speed is reduced. In the Sense Coil version this input is connected to the AC motor sense coil.

### 6.1.2 CNB external connector

B1	PEB	This pin outputs the positive supply (equal to +Batt) of the electromechanical brake coil. Depending on hardware configuration this pin can be controlled by the microcontroller or tied to the B2 input or to the C6 input. See connection drawing for more details.
B2	PEV	Connect the positive supply of all electrovalves (EV1, EV2, EV3, LOWER EVP, HORN OUT) to this pin. Take the positive supply immediately after main contactor.
B3	NEVP	Output of the lower proportional electrovalve driver (driving to –Batt). Built-in freewheeling diode to B2.
B4	DI3	Input of the switch DI3. The input is activated when it is connected to +Batt. The default function is the controller “ <b>FORWARD</b> ” request input, closing this input truck moves in forward direction.
B5	NEB	Electro mechanic brake coil driver output; PWM controlled; 2.5A maximum continuous current (driving to –Batt). Built-in freewheeling diode to B1.
B6	NLC	Min Contactor coil driver output; PWM controlled; 1A maximum continuous current (driving to –Batt). Built-in freewheeling diode.
B7	HORN	Negative of the protected horn electrovalve driver (driving to –Batt). Built-in freewheeling diode to B2.
B8	DI4	Input of the switch DI4. The input is activated when it is connected to +Batt. The default function is the controller “ <b>REV</b> ” request input, closing this input truck moves in backward direction.

### 6.1.3 CNC external connector

C1	+KEY	Input of the key switch signal.
C2	DI1	Input of the switch DI1. The input is activated when it is connected to +Batt. The default function is the controller “ <b>BELLY</b> ” input, closing the switch quick inversion function is activated.
C3	NPOT	Potentiometers negative reference (GND).



C4	CPOTTR	Accelerator potentiometer wiper input.
C5	CANH	High level CAN-BUS voltage I/O.
C6	DI0	Input of the switch DI0. The input is activated when it is connected to +Batt. With the logic hardware properly configured it can be used to supply the EB and MC positive voltage. The default function is the controller “TILLER” input.
C7	DI2	Input of the switch DI7. The input is activated when it is connected to +Batt. The default function is the controller “H&S” (Hard & Soft) request input, closing this input truck performances are modified.
C8	PPOT	Potentiometers positive supply. Hardware has to be configured to output +12V or +5 V.
C9	CPOTL	Lift/Lower potentiometer wiper input.
C10	CANL	Low level CAN-BUS voltage I/O.

#### 6.1.4 CND external connector

D1	ENC A	Traction motor encoder phase A.
D2	PENC	Encoder Positive Supply. Hardware has to be configured to output +12V or +5 V
D3	PTHERM	Traction motor thermal sensor input. The internal pull-up is a fixed 2mA (Max 5V) source current.
D4	ENCB	Traction motor encoder phase B.
D5	NENC	Negative of the Encoder.
D6	NTHERM	Negative reference (GND) for the motor thermal sensor.

#### 6.1.5 CNE internal connector

The connector used is a 8 way STRIP

E1		Not used Internally disconnected.
E2	NCLRxD	Negative serial reception pin.
E3	PCLTXD	Positive serial transmission pin.
E4	NCLTXD	Negative serial transmission pin.
E5	GND	Serial communication negative reference.
E6	+12	+12V serial communication supply.
E7	FLASH BOOT	To connect this pin to GND (E8) for software download via serial communication.
E8	GND	Serial communication negative reference.

This connector cannot be reached without removing the cover. It is used by Zapi for software download with Zapi Flasher, for communicating with a Zapi Handset or a lap-top, for controller setup and for diagnosis.

# 7 DESCRIPTION OF POWER CONNECTIONS

View of the power bars:

- B Negative of the battery.
- + B Positive of the battery.
- P Output of the Pump Motor (COMBIACX only).

U; V; W Connection bars of the three motor phases; follow this sequence and the indication on the motor.

# 8 DRAWINGS

## 8.1 Mechanical drawing COMBIACX

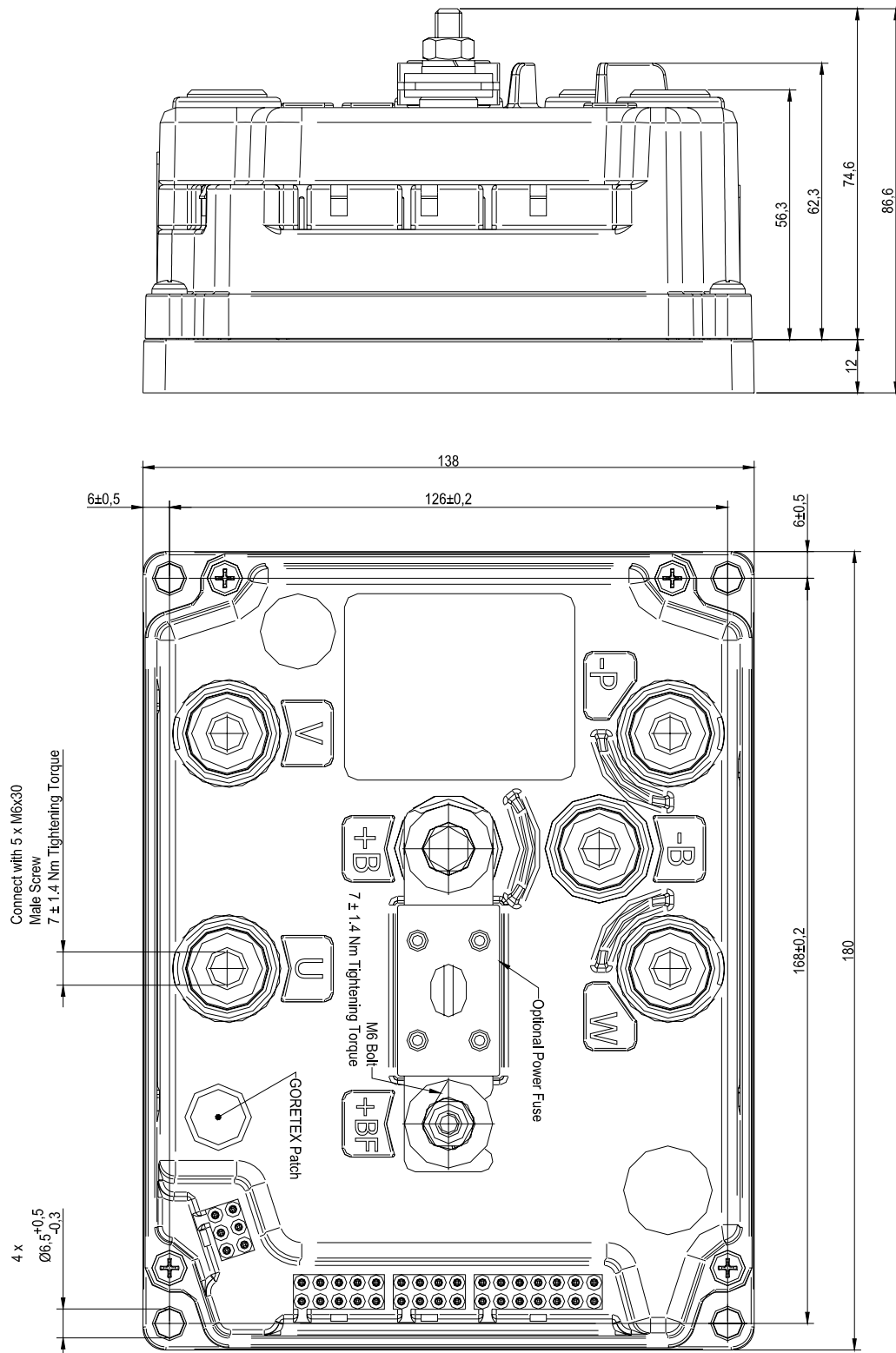

## 8.2 Mechanical drawing ACEX

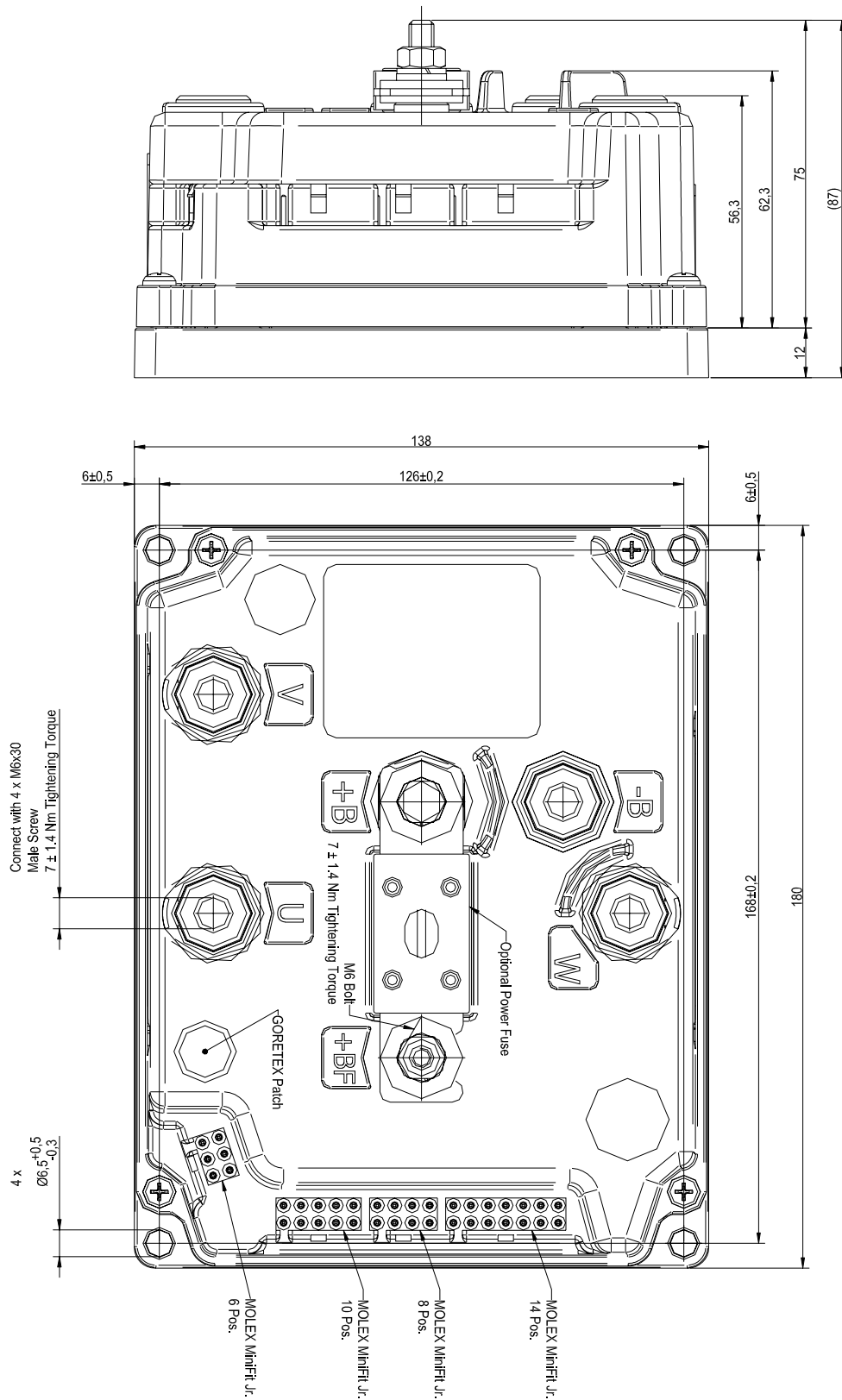

## 8.3 Connection drawing COMBIACX

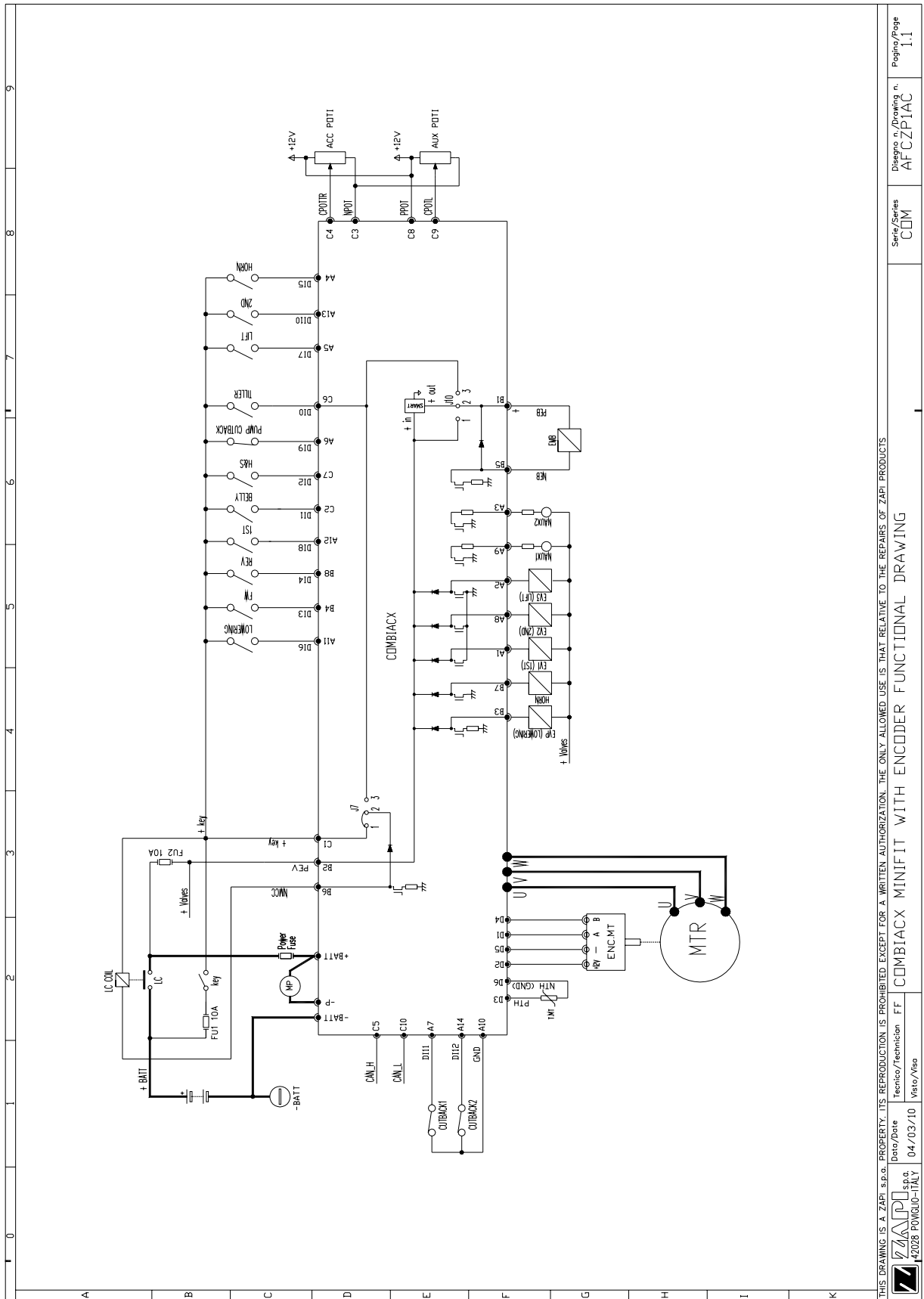

THIS DRAWING IS A ZAPI s.p.a. PROPERTY. ITS REPRODUCTION IS PROHIBITED EXCEPT FOR A WRITTEN AUTHORIZATION. THE ONLY ALLOWED USE IS THAT RELATIVE TO THE REPAIRS OF ZAPI PRODUCTS.	
	Date/Date: 04/03/10 Technico/Technician: FF Viso/Viso:
Serie/Series: COM Disegno n./Drawing n.: AFCZPIAC	Pagina/Page: 1.1
<b>COMBIACX MINIFIT WITH ENCODER FUNCTIONAL DRAWING</b>	

## 8.4 Connection drawing ACEX

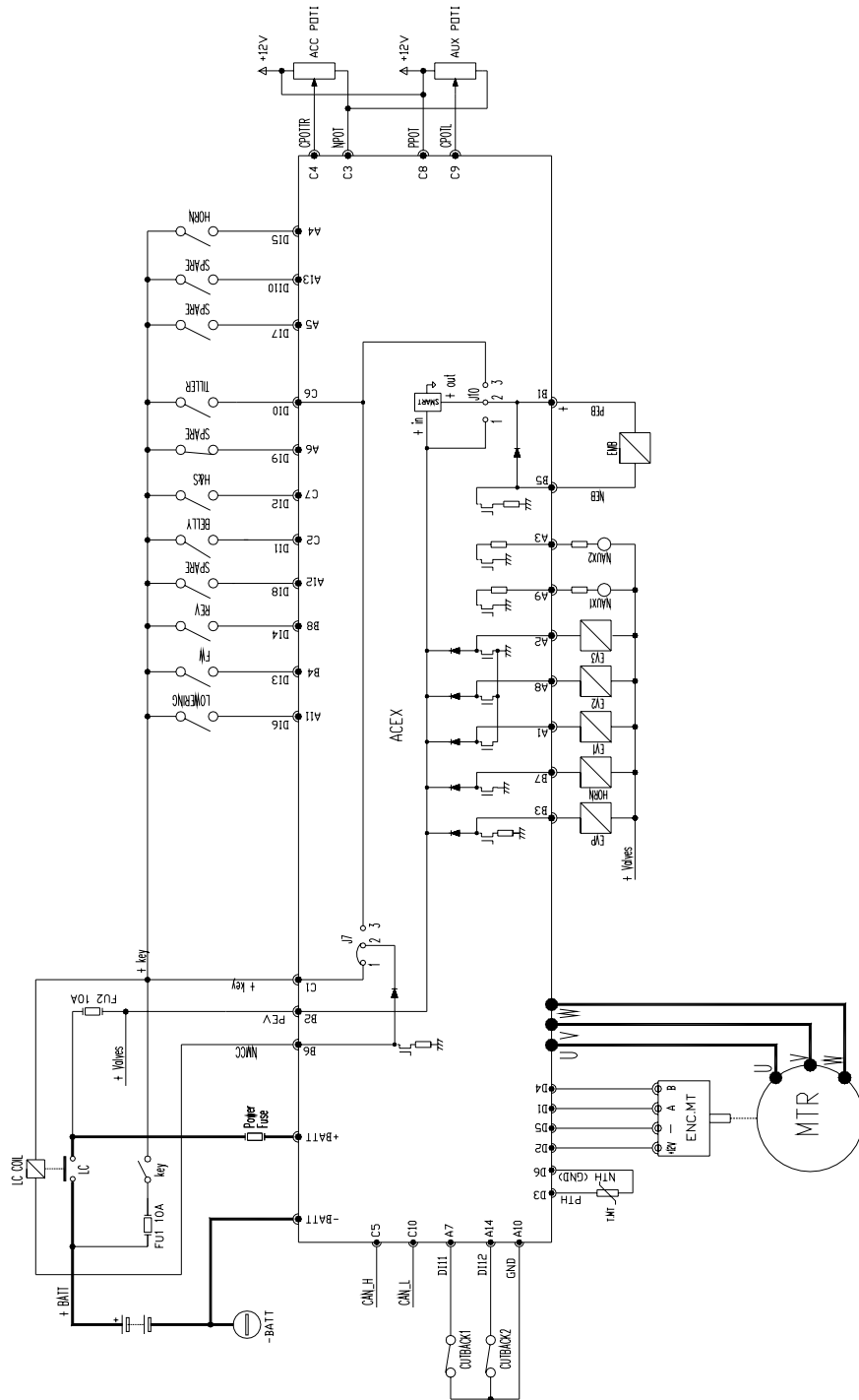

S.p.a. PROPERTY. ITS REPRODUCTION IS PROHIBITED EXCEPT FOR A WRITTEN AUTHORIZATION. THE ONLY ALLOWED USE IS THAT RELATIVE TO THE REPAIRS OF ZAPI PRODUCTS		Disegno n. / Drawing n.	Page/Page
		AFCZP1BB	1.1
		Series/Series	
		COM	
ACEX MINIFIT WITH ENCODER FUNCTIONAL DRAWING			
Date/Date	Technic/Technician		
10/01/11	FF		
	Visor/Visor		

# 9 ONE SHOT INSTALLATION PROCEDURE

This section of the manual describes the basic connection procedure. To move, the truck needs a minimum I/O outfit that it is mandatory: this minimum outfit is listed in the Steps from 1 to 8 below.

- Step1** Connect a potentiometer in the range 0.5 to 10Kohms, to modify the wished speed between +12V / +5V (CNC#8) and GND (CNA#3). The potentiometer wiper is connected to CPOTTR (CNC#4).
- Step2** Connect two travel demand switches. The FWD travel demand must be connected between a battery (key) voltage and CNB#4. The REV travel demand must be connected between a battery (key) voltage and CNB#8. Only one of them can be active at the same time. They become active when connected to a key.
- Step3** Connect a tiller (or seat) switch enabling/disabling the truck motion between CNC#6 and a key voltage. It becomes active, enabling the motion, when closed to a key voltage.
- Step4** Connect the encoder in the motor shaft between CND#2=VDD, CND#5=GND, CND#1=CHA, CND#4=CHB. The VDD voltage may be 12V or 5V depending on a jumper inside the controller.
- Step5** Connect the plus battery voltage through a key switch at the KEY input CNC#1. This is the input for the controller supply.
- Step6** Connect the Main Contactor Coil to CNC#1 and CNB#6. The contactor must connect the battery positive to the +BATT power terminal of the ACEX / COMBIACX.
- Step7** Connect the motors and the minus battery to the corresponding power terminals of the ACEX / COMBIACX.
- Step8** Connect the Electromechanical Brake coil between CNB#1 and CNB#5; when the tiller switch opens, the electromechanical brake gets de-energized braking the truck.

The Steps from 1 to 8 describe the installation operations that is mandatory to do in order your truck moves. Obviously the ACEX / COMBIACX may execute a wider set of optional services as:

- 1) to handle some speed reductions requests.
- 2) to handle an analog sensor inside the motor.
- 3) to handle a proportional braking.
- 4) to handle a proportional forks lowering valve.
- 5) to handle a pump motor by a chopper.
- 6) to handle a belly switch, for truck quick inversion.
- 7) to handle a proportional input for the forks lifting/lowering.
- 8) to handle a number of on/off E-valves, driving a protected drivers.
- 9) to handle an Horn, driving a protected driver.

You must fill your I/O outfit with your optional functions. The optional functions are shown in the connecting drawing and described in detail inside this manual. The index may help you.

---

## 9.1 Sequence for Ac Inverter traction setting

This section of the manual describes the basic ACEX / COMBIACX set-up procedure.



*To complete this procedure it is necessary to use the Zapi console. Since the COMBIACX/ACEX has no external serial connector, the Zapi console has to be connected through a remote module, like a Zapi tiller card of a Zapi display. This module has to be connected to the same Canbus line of the inverter.*



*Otherwise it is possible to connect a pc to the Canbus line and use the PC CAN Console software. This tool is more powerful than the standard serial console.*

---

When the "Key Switch" is closed, if no alarms or errors are present, the Console Display will be showing the Standard Zapi Opening Display (Home Display).

For the setting of your truck, use the procedure below.

If you need to reply the same setting on different controller, use the Save and Restore sequence as described in the 13.1 and 13.2 paragraphs. Remember to recycle the Key Switch if you make any changes to the chopper's configuration.

- Step1** Fill your setting with the Options you need.
- Step2** Select the Battery Voltage.
- Step3** Check the correct installation of all wires. Use the Console's TESTER function to assist.
- Step4** Perform the accelerator signal acquisition procedure using the Console "PROGRAM VACC". Procedure is detailed on paragraph 13.3.
- Step5** Set the "MAXIMUM CURRENT" Current parameter.
- Step6** Set the ACCELERATION DELAY requirements for the machine. Test the parameters in both directions.
- Step7** Set the FREQUENCY CREEP level starting from 0.6 Hz. The machine should just move when the accelerator micro switch is closed. Increase the Level accordingly.
- Step8** Set the Speed Reductions as required. Use the parameters of the "cutback speed" family in the PARAMETER CHANGE menu to specify the reduced maximum truck speed as a percentage of the MAX SPEED FWD and MAX SPEED REV.
- Step9** RELEASE BRAKING. Operate the machine at full speed. Release the accelerator. Adjust the level to your requirement. If the machine is a forklift, check the performance with and without load.
- Step10** INVERSION BRAKING. Operate the machine at 25% full speed. While travelling invert the Direction Switch. Set the suited Level of Inversion Braking. When satisfactory, operate the machine at Full Speed and repeat. If the machine is a Forklift, repeat the tests and make adjustments with and without load. The unloaded full speed condition should be the most representative condition.
- Step11** Set the parameter MAX SPEED FORW.



- Step12** Set the parameter MAX SPEED BACK (Reverse).
- Step13** Test the truck on the maximum ramp specification at full load.
- Step14** Make the choice for the truck behaviour on a slope. If the "Stop on ramp" option is ON, set the desired value of "auxiliary time" parameter.

# 10 PROGRAMMING & ADJUSTMENTS USING DIGITAL CONSOLE

## 10.1 Adjustments via console



To access and adjust all parameters it is necessary to use the Zapi console. Since the COMBIACX/ACEX has no external serial connector, the Zapi console has to be connected through a remote module, like a Zapi tiller card of a Zapi display. This module has to be connected to the same Canbus line of the inverter.



Otherwise it is possible to connect a pc to the Canbus line and use the PC CAN Console software. This tool is more powerful than the standard serial console.

The following paragraphs describe the controller configuration in the case the operator is using the Zapi console.

## 10.2 Description of console (hand set) & connection

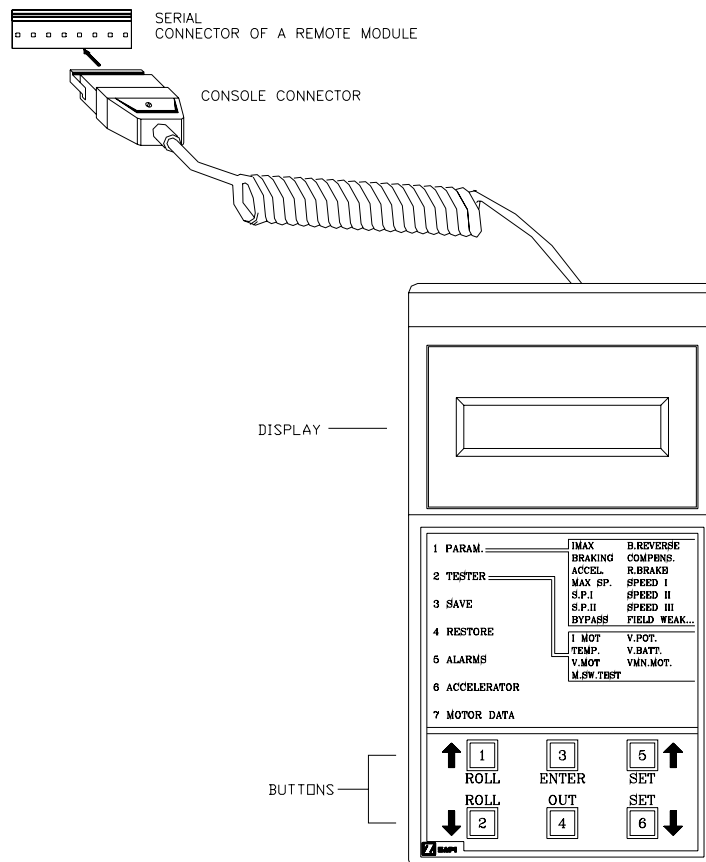

# 10.3 Description of the console menu

## 10.3.1 COMBIACX / ACEX Menu

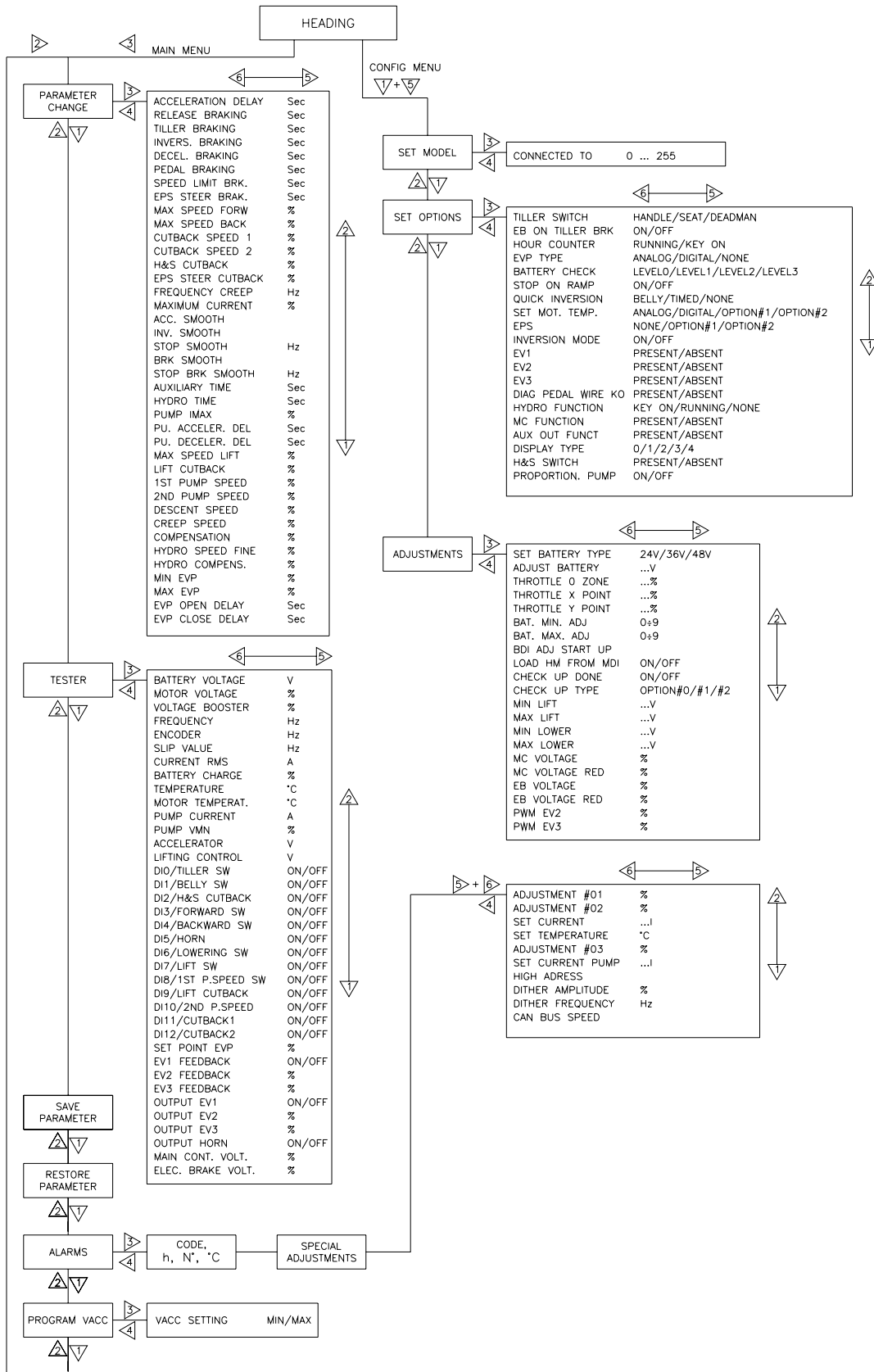

## 10.4 Function configuration

### 10.4.1 Config menu “SET OPTIONS” functions list

To enter the CONFIG MENU' it is necessary to push in the same time the right side top and left side top buttons. Then roll until the SET OPTION item appears on the hand set display. Push the ENTER button.

Opening Zapi Display

ADXT2B ZP1.00  
24V 165A 00000

Push ROLL UP + SET UP simultaneously to enter CONFIG MENU

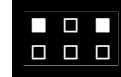

The Display will show : SET MODEL

CONFIG MENU  
SET MODEL

Press ROLL UP or ROLL DOWN button until SET OPTIONS menu appear.



The Display will show : SET OPTIONS

CONFIG MENU  
SET OPTIONS

Press ENTER to go in the SET OPTIONS MENU

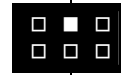

The Display will show the first OPTION

HOURCOUNTER  
RUNNING

Press SET UP or SET DOWN button in order to modify the OPTION



The Display will show the new option

HOURCOUNTER  
KEYON

Press OUT to exit the menu



The Display will ask “ARE YOU SURE”.

ARE YOU SURE?  
YES=ENTER NO=OUT

Press ENTER for YES, or OUT for No



The Display will show : SET OPTIONS

CONFIG MENU  
SET OPTIONS

Press OUT again. Display now will show the opening Zapi menu.

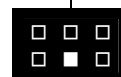

### 1) TILLER SWITCH

This option handles the input CNC#6. This input opens when the operator leaves the truck (tiller released). It is connected to a key voltage when the operator is present. There are two levels:

- HANDLE: CNC#6 is managed as tiller input (no delay when released and INCORRECT START if the input is active at startup).
- SEAT: CNC#6 is managed as seat input (with a delay when released → de-bouncing function and NO INCORRECT START if the input is active at startup).
- DEADMAN: CNC#6 is managed as deadman input, with the same delay of a seat input, but with INCORRECT START if the input is active at startup.

### 2) EB ON TILLER BRK

- ON: The EB is applied when the traction decelerates because CNC#6 was deactivated whilst moving.
- OFF: The EB is NOT applied when the traction decelerates because CNC#6 was deactivated whilst moving.



*Note: if the positive of the EB is coming from the tiller input this option is meaningless because EB is applied mechanically as soon as CNC#6 becomes OFF*

---

### 3) HOUR COUNTER

This option specifies the hour counter mode. It can be set one of two:

- RUNNING: The counter registers travel time only
- KEY ON: The counter registers when the "key" switch is closed (controller supplied)

### 4) EVP TYPE

Analog/digital: defines the type of the EVP electrovalve, current controlled:  
Analog: the related output manages a proportional valve, current controlled  
Digital: the related output manages an on/off valve

### 5) BATTERY CHECK

This option specifies the handling of the low battery charge detection. There are three levels:

- Level 0: Nothing happens, the battery charge level is calculated but is ignored, it means no action is taken when the battery is discharged.
- Level 1: BATTERY LOW alarm is raised when the battery level is calculated being less than or equal to 10% of the full charge. The BATTERY LOW alarm reduces the maximum speed down to 24% of the full speed and reduces the maximum current down to 50% of the full current.
- Level 2: BATTERY LOW alarm is raised when the battery level is calculated being less or equal to 10% of the full charge.
- Level 3: BATTERY LOW alarm is raised when the battery level is calculated being less or equal to 10% of the full charge. The BATTERY LOW alarm reduces the maximum speed down to 24% of the full speed.

### 6) STOP ON RAMP

Only when the encoder is present, it is possible to electrically hold the truck on a slope when the accelerator is released but the tiller is not released.

- ON: The stop on ramp feature (truck electrically hold on a ramp) is managed

for a time established by AUXILIARY TIME parameter.

- OFF: The stop on ramp feature is not performed. That means the truck comes down slowly during the AUXILIARY TIME.

After this “auxiliary time”, the electromechanical brake is applied and the 3-phase bridge is released; if the electromechanical brake is not present the truck comes down very slowly (see the AUX OUTPUT #1 option programming and see also 13.4).

## 7) QUICK INVERSION

It can be set:

- NONE: The quick inversion function is not managed (no effect when CNC#2 switches over).
- TIMED: The quick inversion function is timed.
- BELLY: The quick inversion function is managed but not timed.

## 8) SET MOTOR TEMPERATURE

It can be set:

- OPTION#1: An analog sensor for the control of the motor temperature is connected to CND#3. The temperature sensor is a KTY 84-130 PTC (positive thermal coefficient resistance).
- OPTION#2: An analog sensor for the control of the motor temperature is connected to CND#3. The temperature sensor is a KTY-83 PTC.
- 1. DIGITAL: A digital (on/off) sensor for the motor temperature monitoring is connected to CND#3 input.
- 2. NONE: No temperature sensor is connected.

## 9) EPS

It can be set:

- NONE: NO EPS is present on the truck, CombiACX does not wait for CAN messages by the EPS and it does not apply EPS and braking steer cutback.
- OPTION#1: EPS is present and it is an EPS-AC0, ENCODER + TOGGLE SWITCHES type.
- OPTION#2: EPS is present and it is an EPS-AC0, POT + ENCODER type.

## 10) INVERSION MODE

ON/OFF: This parameter sets the logic of the Quick Inversion input. If set = ON, the Quick Inversion switch is Normally Closed (function active when switch opens). If set = OFF, the Quick Inversion switch is Normally Open (function active when switch closes).

## 11) EV1

PRESENT/ABSENT: If set = PRESENT the EV1 output is driven and the diagnosis “EV1 DRIVER SHORTED” relative to the load connected to CNA#1 is activated. When set = ABSENT the diagnosis is not implemented and the EV1 output is NOT driven.

## 12) EV2

PRESENT/ABSENT: If set = PRESENT the EV2 output is driven and the diagnosis “EV2 DRIVER SHORTED” relative to the load connected to CNA#8 is activated. When set = ABSENT the diagnosis is not implemented and the EV2 output is NOT driven.

## 13) EV3

PRESENT/ABSENT: If set = PRESENT the EV3 output is driven and the

diagnosis “EV3 DRIVER SHORTED” relative to the load connected to CNA#2 is activated. When set = ABSENT the diagnosis is not implemented and the EV3 output is NOT driven.

**14) HORN**

PRESENT/ABSENT: If set PRESENT, the HORN output is driven. When set ABSENT the HORN output is NOT driven.

**15) HYDRO FUNCTION**

KEY ON/RUNNING/NONE: Defines the activation of hydraulic steering function.

- KEY ON: the function is activated at key-on.
- RUNNING: the function is activated during a traction or braking request.
- NONE: the function is never activated.

**16) M.C. FUNCTION**

PRESENT/ABSENT: When is set PRESENT the Main Contactor is closed after the controller key-on if the initial diagnosis pass. If is set ABSENT the diagnosis are masked and M.C. is not closed after controller Key-on.

**17) AUX OUT FUNCTION**

PRESENT/ABSENT: When is set PRESENT the Electro mechanic Brake is driven after a traction request if all the related diagnosis pass. If is set ABSENT the diagnosis are masked and E.B. is not closed after a traction request.

**18) PROPORTION. PUMP**

ON/OFF: When is set ON the lift functions are proportional. The pump motor speed increase if the analog value of CPOTL increase. If is set ABSENT the analog value CPOTL is not read and the speed of pump motor is set maximum when the digital input is closed (LIFT).

**10.4.2 Config menu “ADJUSTMENTS” functions list**

To enter the CONFIG MENU it is necessary to push in the same time the right side top and left side top buttons. Then roll until the ADJUSTMENTS item appears on the hand set display. Push the ENTER button.

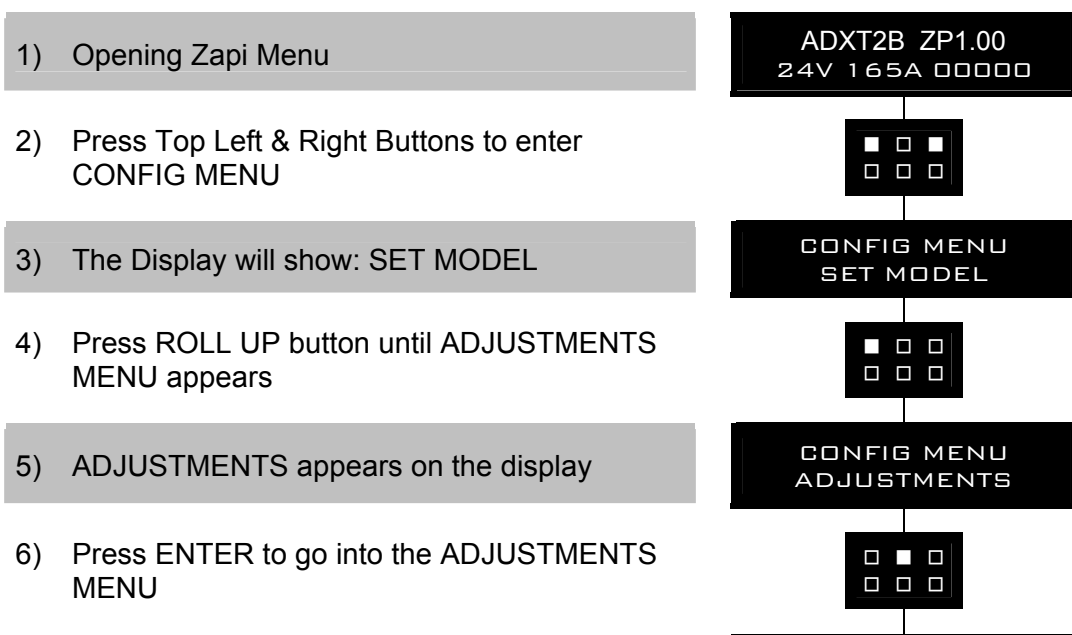

7) The display will show: SET BATTERY TYPE

8) Press ROLL UP or ROLL DOWN button until the desired parameter is reached

9) The desired parameter appears

10) Press SET UP or SET DOWN button to modify the adjustment

11) Press OUT

12) Press ENTER to confirm

13) Repeat the same from 5 to 12 points for the other adjustments

**1) SET BATTERY TYPE**

Selects the nominal battery voltage.

**2) ADJUST BATTERY**

Fine adjustment of the battery voltage measured by the controller.

**3) THROTTLE 0 ZONE**

Establishes a dead-band in the accelerator input curve.

**4) THROTTLE X POINT**

This parameter, together with the THROTTLE Y POINT, changes the characteristic of the accelerator input curve : when the accelerator is de-pressed to X point per cent, the corresponding truck speed is Y point per cent of the Maximum truck speed. The relationship between the accelerator position and the truck speed is linear between the THROTTLE 0 ZONE and the X point and also between the X point and the maximum accelerator position but with two different slopes.

**5) THROTTLE Y POINT**

This parameter, together with the THROTTLE X POINT, changes the characteristic of the accelerator input curve (see also paragraph 13.5): when the accelerator is de-pressed to X point per cent, the corresponding truck speed is Y point per cent of the Maximum truck speed. The relationship between the accelerator position and the truck speed is linear between the THROTTLE 0 ZONE and the X point and also between the X point and the maximum accelerator position but with two different slope.

**6) BAT. MIN ADJ.**

Adjust the lower level of the battery charge table (Level 0 to 9).

**7) BAT. MAX ADJ.**

Adjust the upper level of the battery charge table (Level 0 to 9).

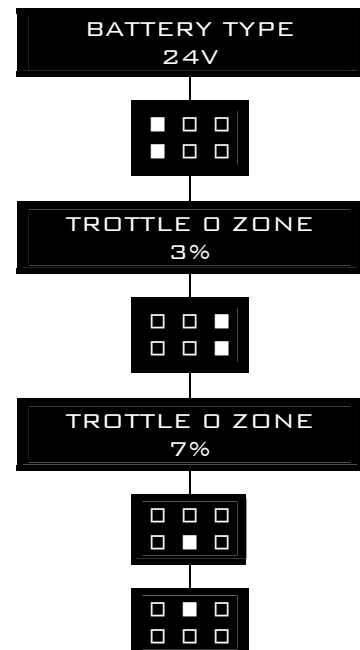



**8) BDI ADJ START UP**

It selects the type of algorithm used to estimate the battery discharge. Each level corresponds to a different set of parameters of the algorithm.

**9) LOAD HM FROM MDI**

When set On, the HourMeter of the Controller is transferred and recorded on the HourMeter of the MDI CAN, connected to CAN BUS network.

**10) CHECK UP DONE**

It can be ON/OFF. If it is ON it is possible to reset the last maintenance hour-counter and the "CHECK UP NEEDED" warning.

**11) CHECK UP TYPE**

It specifies the handling of the CHECK UP NEEDED warning:

- NONE: No CHECK UP NEEDED warning
- OPTION#1: CHECK UP NEEDED warning shown on the hand set and MDI/DISPLAY after 300 hours
- OPTION#2: Equal to OPTION#1 but Speed reduction after 340 hours
- OPTION#3: Equal to OPTION#2 but the truck definitively stops after 380 hours

**12) MIN LIFT**

This parameter stores the minimum voltage of lifting potentiometer output connected to CNC#9. The min value acquisition is done closing the Lift SW and bringing the potentiometer in its min output position.

**13) MAX LIFT**

This parameter stores the maximum voltage of lifting potentiometer output connected to CNC#9. The max value acquisition is done closing the Lift SW and bringing the potentiometer in its max output position.

**14) MIN LOWER**

%. This parameter stores the minimum voltage of lowering potentiometer output connected to CNC#9. The min value acquisition is done closing the LOWER SW (DI6) and bringing the potentiometer in its min output position.

**15) MAX LOWER**

%. This parameter stores the maximum voltage of lifting potentiometer output connected to CNC#9. The min value acquisition is done closing the LOWER SW (DI6) and bringing the potentiometer in its min output position.

**16) MC VOLTAGE**

%. This parameter stores the PWM value applied to MC coil during the first second of the output activation. It is expressed in percentage of battery voltage.

**17) MC VOLTAGE RED**

%. This parameter stores the PWM value applied to MC coil after the first second of the output activation. It is expressed in percentage of the voltage applied during the first second (defined by the previous parameter).

**18) EB VOLTAGE**

%. This parameter stores the PWM value applied to EB coil during the first second of the output activation. It is expressed in percentage of battery voltage.

**19) EB VOLTAGE RED**

%. This parameter stores the PWM value applied to EB coil after the first second of the output activation. It is expressed in percentage of the voltage applied during the first second (defined by the previous parameter).

**20) PWM EV2**

%. This parameter stores the PWM value applied to the EV2 coil. It is expressed in percentage of battery voltage.

**21) PWM EV3**

%. This parameter stores the PWM value applied to the EV3 coil. It is expressed in percentage of battery voltage.

### 10.4.3 Main menu “PARAMETER CHANGE” functions list

To enter the MAIN MENU’ it is just necessary to push the ENTER button from the home display in the hand set.

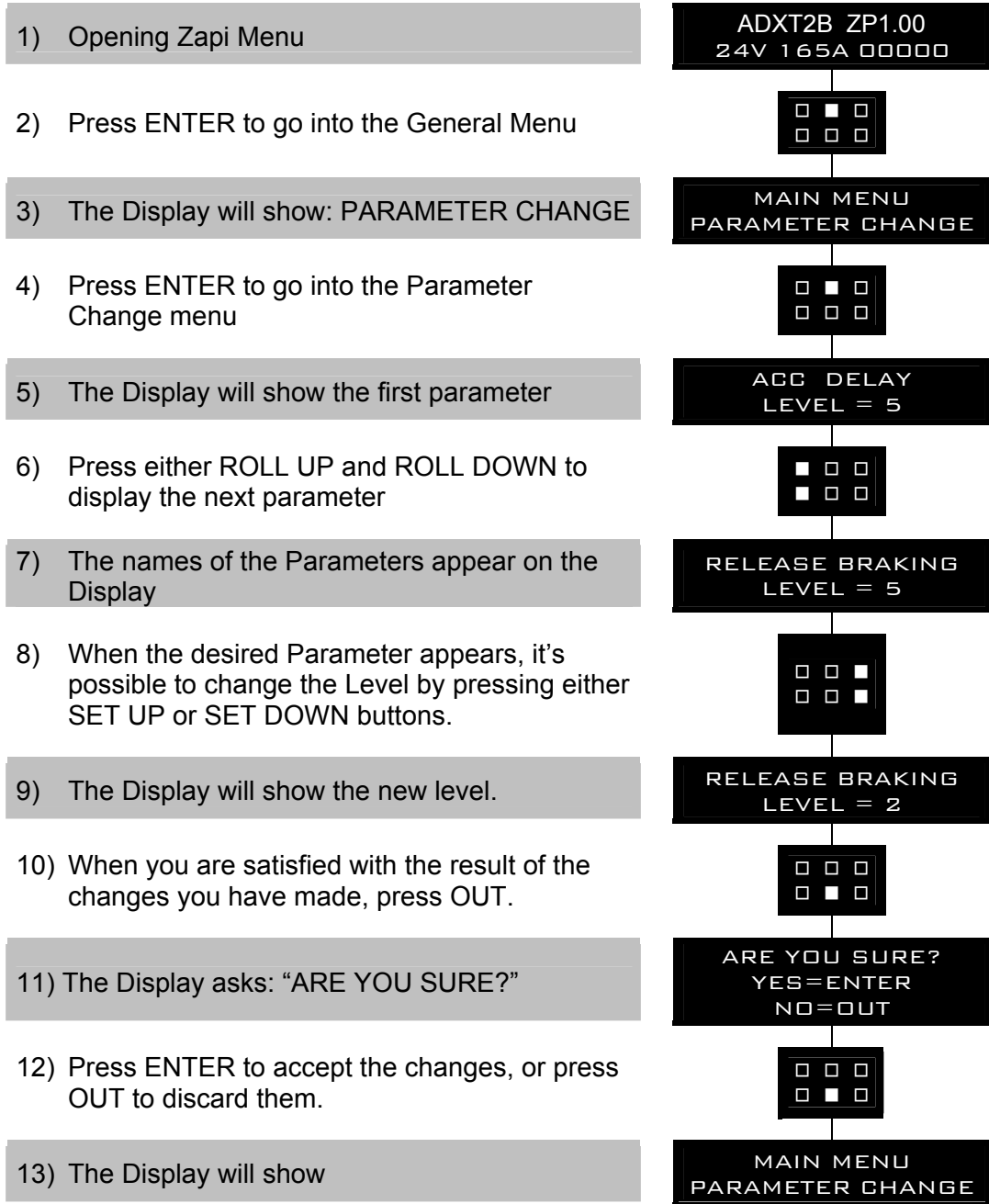

**1) ACCELER. DELAY**

Seconds. It determines the acceleration ramp. The parameter sets the time needed to speed up the traction motor from 0Hz to 100Hz.

**2) RELEASE BRAKING**

Seconds. It controls the deceleration ramp when the travel request is released. The parameter sets the time needed to decelerate the traction motor from 100Hz to 0Hz.

- 3) TILLER BRAKING**  
Seconds. It controls the deceleration ramp when the tiller is in braking position (released). The parameter sets the time needed to decelerate the traction motor from 100Hz to 0Hz
- 4) INVERS. BRAKING**  
Seconds. It controls the deceleration ramp when the direction switch is inverted during travel. The parameter sets the time needed to decelerate the traction motor from 100Hz to 0Hz.
- 5) DECEL. BRAKING**  
Seconds. It controls the deceleration ramp when the accelerator has turned down but not completely released. The parameter sets the time needed to decelerate the traction motor from 100Hz to 0Hz.
- 6) PEDAL BRAKING**  
Seconds. This parameter determines the deceleration ramp when the travel request is released and the brake pedal switch is closed. It sets the time needed to decelerate the traction motor from 100Hz to 0Hz.
- 7) SPEED LIMIT BRK**  
Seconds. It controls the deceleration ramp when a speed reduction has been activated. The parameter sets the time needed to decelerate the traction motor from 100Hz to 0Hz.
- 8) EPS STEER BRAK.**  
Seconds. It controls the deceleration ramp when a steer cutback is applied. The parameter sets the time needed to decelerate the traction motor from 100Hz to 0Hz.  
If EPS option is set to NONE, this parameter is useless.
- 9) MAX SPEED FORW**  
Percentage. It determines the maximum speed in forward direction.
- 10) MAX SPEED BACK**  
Percentage. It determines the maximum speed in backward direction.
- 11) CUTBACK SPEED 1**  
Typically from 10% to 100%. It determines the percentage of the max speed applied when the cutback switch, CNA#7 connector, is active. When set to 100% the speed reduction is ineffective.
- 12) CUTBACK SPEED 2**  
Typically from 10% to 100%. It determines the percentage of the max speed applied when the cutback switch, CNA#14 connector, is active. When set to 100% the speed reduction is ineffective.
- 13) H&S CUTBACK**  
Typically from 10% to 100%. It determines the percentage of the max speed applied when the Hard & Soft function, CNC#7 connector, is active. When set to 100% the speed reduction is ineffective.
- 14) H&S CUTBACK**  
Typically from 10% to 100%. If H&S SWITCH option is PRESENT and POSITIVE EB option is not LEVEL 1, it determines the percentage of the max

speed applied when the Hard & Soft function, CNC#7 connector, is active. When set to 100% the speed reduction is ineffective.

#### **15) EPS STEER CUTBACK**

Typically from 1% to 100%. It determines the percentage of the maximum speed when the wheel is completely turned (tipicclly 90 degrees). If the wheel angle is a percentage of the maximum angle, the steer cutback is applied proportionally.



*Note: the wheel angle is coming from EPS. If EPS option is set to NONE, this parameter is useless.*

---

#### **16) FREQUENCY CREEP**

Hz value. This is the minimum speed applied when the forward or reverse switch is closed, but the accelerator is at its minimum.

#### **17) MAXIMUM CURRENT**

Maximum level of the current (percentage of the maximum current of the controller).

#### **18) ACCELERATION SMOOTH**

It gives a parabolic form to the acceleration ramp.

#### **19) INVERSION SMOOTH**

It gives a parabolic form to the acceleration ramp after a direction inversion.

#### **20) STOP SMOOTH**

Hz. It sets the level of frequency where the smooth effect of the acceleration parabolic form ends.

#### **21) BRK SMOOTH**

It gives a parabolic form to the deceleration ramp.

#### **22) STOP BRK SMOOTH**

Hz. It sets the level of frequency where the smooth effect of the deceleration parabolic form ends.

#### **23) AUXILIARY TIME**

Time units value (seconds). For the encoder version, it determines the time duration the truck is hold on the ramp if the STOP ON RAMP option is ON.

#### **24) HYDRO TIME**

Sec. It determines the time duration the pump motor is driven after the hydraulic request is released.

#### **25) PUMP IMAX**

Level 0 to 9. Set the maximum current for the pump motor.

#### **26) PUMP ACCELERATION DELAY**

In seconds. Set the acceleration ramp for the pump motor.

**27) PUMP DECELERATION DELAY**

In seconds. Set the deceleration ramp for the pump motor.

**28) MAX SPEED LIFT**

From 0% to 100%. It limits the maximum speed of the lift function. Percentage of the maximum voltage applied to the pump motor for the lift function. If it is set 0% the motor does not work when the lift request is ON.

**29) LIFT CUTBACK**

From 0% to 100%. It reduces the maximum speed of the lift function when the pump cutback switch, CAN#6 connector, is active.

When set to a percentage which is higher than MAX SPEED LIFT, the pump speed reduction is ineffective.

If set 0% the motor is stopped when the pump cutback switch is ON.

**30) 1<sup>ST</sup> PUMP SPEED**

From 0% to 100%. It limits the speed of the 1ST function. Percentage of the voltage applied to the pump motor for the 1ST function. If it is set 0% the motor don't work when the 1ST request is ON.

**31) 2<sup>ND</sup> PUMP SPEED**

From 0% to 100%. It limits the speed of the 2ND function. Percentage of the voltage applied to the pump motor for the 2ND function. If it is set 0% the motor don't work when the 2ND request is ON.

**32) DESCENT SPEED**

From 0% to 100%. It limits the maximum speed of the descent function.

Percentage of the maximum voltage applied to the pump motor for the descent function. If it is set 0% the motor don't work when the descent request is ON.

**33) CREEP SPEED**

Percentage. It sets the minimum speed (percentage of voltage applied) for the pump motor. Percentage of the maximum voltage applied to the pump motor when the Lift SW is closed.

**34) COMPENSATION**

From 0% to 100% This parameter sets the voltage compensation ( $\Delta V$ ) applied to the motor when the proportional lifting function is active. The value of this  $\Delta V$  applied to the motor is a function of the motor current. Aim of this function is to reduce, as for as possible, the speed difference between the truck loaded and unloaded.

**35) HYD SPEED FINE**

Percentage. Fine adjustment of the pump motor steering function speed.

**36) HYDRO COMPENSATION**

Percentage. Adjustment of the compensation function when the pump motor steering function is active.

**37) MIN EVP**

0 to 100. This parameter determines the minimum current applied on the EVP when the position of the potentiometer is at the minimum. This parameter is not effective if the EVP is programmed like a On/Off valve.

**38) MAX EVP**

From 0 to 100. This parameter determines the maximum current applied to the EVP when the position of the potentiometer is at the maximum. This parameter also determines the current value when the EVP is programmed like an ON/OFF valve.

**39) EVP OPEN DELAY**

Seconds. It determines the acceleration ramp on EVP.  
The parameter sets the time needed to increase the current to the maximum possible value.

**40) EVP CLOSE DELAY**

Seconds. It determines the deceleration ramp on EVP.  
The parameter sets the time needed to decrease the current from the maximum possible value to zero.

PARAMETER	UNIT	VALUE
ACCELERATION DELAY	Sec.	From 0 to 10 sec., resolution of 0.1
RELEASE BRAKING	Sec.	From 0 to 10 sec., resolution of 0.1
TILLER BRAKING	Sec.	From 0 to 10 sec., resolution of 0.1
INVERSION BRAKING	Sec.	From 0 to 10 sec., resolution of 0.1
DECEL. BRAKING	Sec.	From 0 to 10 sec., resolution of 0.1
PEDAL BRAKING	Sec.	From 0 to 10 sec., resolution of 0.1
SPEED LIMIT BRAKING	Sec.	From 0 to 10 sec., resolution of 0.1
MAX SPEED FW	%	From 0% to 100%, resolution of 1%
MAX SPEED BW	%	From 0% to 100%, resolution of 1%
CUTBACK SPEED 1	%Max Sp	From 0% to 100%, resolution of 1%
CUTBACK SPEED 2	%Max Sp	From 0% to 100%, resolution of 1%
H&S CUTBACK	%Max Sp	From 0% to 100%, resolution of 1%
FREQUENCY CREEP	Hz	From 0.6 to 4.0 Hz, resolution of 0.1 Hz
MAXIMUM CURRENT	%IMAX	From 0% to 100%, resolution of 1%
ACC SMOOTH	Num.	From 1 to 5, resolution 0,1
INV SMOOTH	Num.	From 1 to 5, resolution 0,1
STOP SMOOTH	Hz	From 3 to 20 Hz, resolution of 1Hz
BRK SMOOTH	Num.	From 1 to 5, resolution 0,1
STOP BRAKE SMOOTH	Hz	From 3 to 20 Hz, resolution of 1Hz
AUXILIARY TIME	Sec.	From 0 to 10 sec., resolution of 0.1
HYDRO TIME	Sec.	From 0 to 10 sec., resolution of 0.1
PUMP IMAX	%	Programmed level from 0 to 9
PU. ACCELER. DEL.	Sec.	From 0 to 10 sec., resolution of 0.1
PU. DECELER. DEL.	Sec.	From 0 to 10 sec., resolution of 0.1
MAX SPEED LIFT	%	From 0% to 100%, resolution of 1%
MAX SPEED LIFT	%	From 0% to 100%, resolution of 1%
LIFT CUTBACK	%	From 0% to 100%, resolution of 1%
1 <sup>ST</sup> PUMP SPEED	%	From 0% to 100%, resolution of 1%
2 <sup>ND</sup> PUMP SPEED	%	From 0% to 100%, resolution of 1%
DESCENT SPEED	%	From 0% to 100%, resolution of 1%
CREEP SPEED	%	From 0% to 100%, resolution of 1%
COMPENSATION	%	From 0% to 100%, resolution of 1%
HYD SPEED FINE	%	From 0% to 100%, resolution of 1%
HYDRO COMPENSATION	%	From 0% to 100%, resolution of 1%
MIN EVP	%	From 0% to 100%, resolution of 0.1%
MAX EVP	%	From 0% to 100%, resolution of 0.1%
EVP OPEN DELAY	Sec.	From 0 to 25.5 sec., resolution of 0.1
EVP CLOSE DELAY	Sec.	From 0 to 25.5 sec., resolution of 0.1



## 10.4.4 Zapi menu “SPECIAL ADJUSTMENTS” functions list

---



*Note: the below set-up description is for skilled persons only: if you aren't, please keep your hands off. To enter this Zapi hidden menu a special procedure is required. Ask for this procedure, directly to a Zapi technician.  
In the SPECIAL ADJUSTMENTS functions list, there are factory adjusted parameters only.*

---

- 1) **ADJUSTMENT #01**  
(Factory adjusted). % value. This is the Gain of the first Current Sensing Amplifier of traction motor.  
**NOTE: only Zapi technicians should change this value**
  - 2) **ADJUSTMENT#02**  
(Factory adjusted). % value. This is the Gain of the second Current Sensing Amplifier of traction motor.  
**NOTE: only Zapi technicians should change this value**
  - 3) **SET CURRENT**  
(Factory adjusted). This is the traction motor maximum current.
  - 4) **SET TEMPERATURE**  
Set the temperature offset to have the correct value reading. This is a fine calibration of the controller temperature sensor.
  - 5) **ADJUSTMENT#03**  
(Factory adjusted). % value. This is the gain of the Current Sensing Amplifier of pump motor.
  - 6) **SET CURRENT PUMP**  
(Factory adjusted). This is the pump motor maximum current.
  - 7) **HIGH ADDRESS**  
To be used to have access to special memory address.
- 



*NOTE: only Zapi technicians should change this value*

---

- 8) **DITHER AMPLITUDE**  
It is the dither signal amplitude. The dither signal is a square wave which is overlapped to the proportional valves set point. In this way the proportional valves response to set point variations is optimized. This parameter is a percentage of the valves maximum current. It can be adjusted in the 0% to 20.3% by nine levels. Setting the parameter to 0% means the dither isn't used.
- 9) **DITHER FREQUENCY**  
It is the dither signal frequency. It can be used one of three:
  - 0: the dither signal frequency is 62.5 Hz
  - 1: the dither signal frequency is 83 Hz
  - 2: the dither signal frequency is 125 Hz.

## 10) CAN BUS SPEED

It determines the baudrate for the CAN communication

- 20: 20 kbaud/sec.
- 50: 50 kbaud/sec.
- 125: 125 kbaud/sec.
- 250: 250 kbaud/sec.
- 500: 500 kbaud/sec.

### 10.4.5 Main menu “TESTER” functions list

The TESTER functions are a real time feedback measurements of the state of the controller/motor/command devices. It is possible to know the state (active / off) of the digital I/Os, the voltage value of the analog inputs and the state of the main variables used in the motor and hydraulics control. Enter the home page in the hand-set display and roll for the TESTER item.

#### 1) BATTERY VOLTAGE

Voltage value with 1 decimal digit. Battery voltage value measured at the key on.

#### 2) MOTOR VOLTAGE

Percentage value. It is the voltage generated by the inverter expressed in percent of the actual battery voltage. 100% means the sine wave width is close to the actual battery voltage; 0% means the sine wave width is null.

#### 3) VOLTAGE BOOSTER

Percentage value. It is the booster contribute to the voltage really supplied to the motor expressed in per cent of the actual battery voltage. (Note: when DC\_LINK COMPENSATION is set ON, the VOLTAGE BOOSTER reading will not match perfectly the booster setting because this latest one is calculated respect to the nominal battery voltage; VOLTAGE BOOSTER is expressed respect to the actual battery voltage).

#### 4) FREQUENCY

Hz value. This is the frequency of the sine waves the inverter is supplying.

#### 5) ENCODER

Hz value. This is the speed of the motor measured with the encoder and expressed in the same unit of the FREQUENCY reading.

#### 6) SLIP VALUE

Hz value. This is the slip between the frequency and the speed of the motor (SLIP VALUE = FREQUENCY-ENCODER).

#### 7) CURRENT RMS

Ampere value. Root Mean Square value of the line current in the motor.

#### 8) BATTERY CHARGE

Percentage value. It supplies the residual charge of the battery as a percentage of the full charge level.

#### 9) TEMPERATURE

°C value. This is the temperature of the inverter base plate. This temperature is used for the HIGH TEMPERATURE alarm detection.

#### 10) MOTOR TEMPERATURE

°C value. This is the temperature of the motor windings picked up with an analog sensor inside the motor. Normally this sensor is a PTC Philips KTY84-130 or a KTY83. It depends on SET MOT. TEMP. option.

#### 11) PUMP CURRENT

Ampere. It is the continuous current in the pump motor.

#### 12) PUMP VMN

It is the voltage applied to the pump motor. Expressed in percentage of the maximum voltage.

#### 13) ACCELERATOR

From 0.0V to 5.0V. The voltage on the wiper of the accelerator (CPOT on CNC#4) is halved inside the controller and then recorded on this reading. That means the actual wiper voltage is in the range 0 to 10V meanwhile the corresponding ACCELERATOR reading is in the range 0.0 to 5.0Vdc.

#### 14) LIFTING CONTROL

From 0.0 to 5.0V. The voltage on the wiper of the accelerator (CPOTLIFT on CNC#9) is halved inside the controller and then recorded on this reading. That means the actual wiper voltage is in the range 0 to 10V meanwhile the corresponding ACCELERATOR reading is in the range 0.0 to 5.0Vdc

#### 15) DI0/TILLER SWITCH

ON/OFF. This is the level of the digital input CNC#6 for the Tiller input.

- ON +VB = When it is closed to a battery (key) voltage, the Tiller input is Active.
- OFF GND = When it is not connected to a battery (key) voltage (or it is connected to GND), the Tiller input is not active.

#### 16) DI1/BELLY SWITCH

ON/OFF. This is the level of the digital input CNC#2 ( belly button):

- ON +VB = When it is closed to a battery (key) voltage, the request of the Belly (to stop the movement) is active.
- OFF GND = When it is not connected to a battery (key) voltage (or it is connected to GND), the Belly request is not active.

#### 17) DI2/ H&S CUTBACK

ON/OFF. This is the level of the digital input CNC#7 for the Hard & Soft request. With the H&S service is possible to turn the truck moving (at reduced speed) only by acting the H&S switch, and the accelerator, without to let down the tiller :

- ON +VB = When it is closed to a battery (key) voltage, the H&S request is Active.
- OFF GND = When it is not connected to a battery (key) voltage (or it is connected to GND), the H&S request is not active.

#### 18) DI3/FORWARD SWITCH

ON/OFF. This is the level of the digital input CNB#4 for the forward travel demand:

- ON +VB = When it is closed to a battery (key) voltage, the Forward Travel demand is Active.
- OFF GND = When it is not connected to a battery (key) voltage (or it is connected to GND), the Forward Travel demand is not active.

**19) DI4/BACKWARD SW.**

ON/OFF. This is the level of the digital input CNB#8 for the backward travel demand:

- ON +VB = When it is closed to a battery (key) voltage, the Backward Travel demand is Active.
- OFF GND = When it is not connected to a battery (key) voltage (or it is connected to GND), the Backward Travel demand is not active.

**20) DI5/HORN SWITCH**

ON/OFF. This is the level of the digital CNA#4:

- ON +VB = When it is closed to a battery (key) voltage the HORN request is active.
- OFF GND = When it is not closed to a battery (key) voltage (or connected to GND) the HORN request is not active.

**21) DI6/LOWERING SW.**

ON/OFF. This is the level of the digital input CNA#11:

- ON +VB = When it is closed to a battery (key) voltage, the request of the Lowering request is active.
- OFF GND = When it is not connected to a battery (key) voltage (or it is connected to GND), the Lowering request is not active.

**22) DI7/LIFT SWITCH**

ON/OFF. This is the level of the digital input CNA#5:

- ON +VB = When it is closed to a battery (key) voltage the voltage the LIFTING request is active.
- OFF GND = When it is not closed to a battery (key) voltage (or connected to GND) the voltage the LIFTING request is not active.

**23) DI8/1ST P.SPEED**

ON/OFF. This is the level of the digital input CNA#12:

- ON +VB = When it is closed to a battery (key) voltage the 1ST request is active.
- OFF GND = When it is not closed to a battery (key) voltage (or it is connected to GND) the 1ST request is not active.

**24) DI9/LIFT CUTBACK**

ON/OFF. This is the level of the digital input CNA#6:

- ON GND = When it is closed not to a battery (key) voltage (or it is connected to GND), the PUMP CUTBACK request is not active.
- OFF +VB = When it is closed to a battery (key) voltage, the PUMP CUTBACK request is active.

**25) DI10/2ND P.SPEED**

ON/OFF. This is the level of the digital input CNA#13:

- ON +VB = When is closed to a battery (key) voltage the digital the 2ND request is active.
- OFF GND = When is not connected to a battery (key) voltage (or it is connected to GND) the 2ND request is not active.

**26) DI11/CUTBACK1**

ON/OFF. This is the level of the CNA#7 digital input:

- ON GND = When CNA#7 is not closed to GND the CUTBACK1 request not is active.

- OFF +VB = When is not connected to GND (or it is connected to battery) the CUTBACK1 request is active.

**27) DI12 CUTBACK 2**

ON/OFF. This is the level of the digital input CNA#14:

- ON GND = When CNA#14 is not closed to GND the CUTBACK2 request not is active.
- OFF +VB = When is not connected to GND (or it is connected to battery) the CUTBACK2 request is active.

**28) SET POINT EVP**

This parameter shows the setpoint of EVP valve.

**29) EV1 FEEDBACK**

ON/OFF. This parameter shows the feedback of EV1 valve.

**30) EV2 FEEDBACK**

VOLTAGE %. This parameter shows the feedback of EV2 valve.

**31) EV3 FEEDBACK**

VOLTAGE %. This parameter shows the feedback of EV3 valve.

**32) OUTPUT EV1**

ON/OFF. This is the EV1 output command.

**33) OUTPUT EV2**

%. This is the EV2 output command (voltage %).

**34) OUTPUT EV3**

%. This is the EV3 output command (voltage %).

**35) OUTPUT HORN**

ON/OFF. This is the HORN output command.

**36) MAIN CONT. VOLT.**

%. This is the main contactor output command (voltage %).

**37) ELEC. BRAKE VOLT.**

%. This is the electrobrake output command (voltage %).

# 11 OTHER FUNCTIONS

## 11.1 Description of console "SAVE" function

The SAVE function allows the operator to transmit the Parameter values and Configuration data of the controller into the Console memory. It is possible to load 64 different programmes. The information saved in the Console memory can then be reloaded into another controller using the RESTORE function.

The data that is available via the SAVE function are listed here below:

- All Parameter Values (PARAMETER CHANGE).
- Options (SET. OPTIONS).
- The Level of the Battery (ADJUST BATTERY).

Flow Chart showing how to use the SAVE function of the Digital Console.

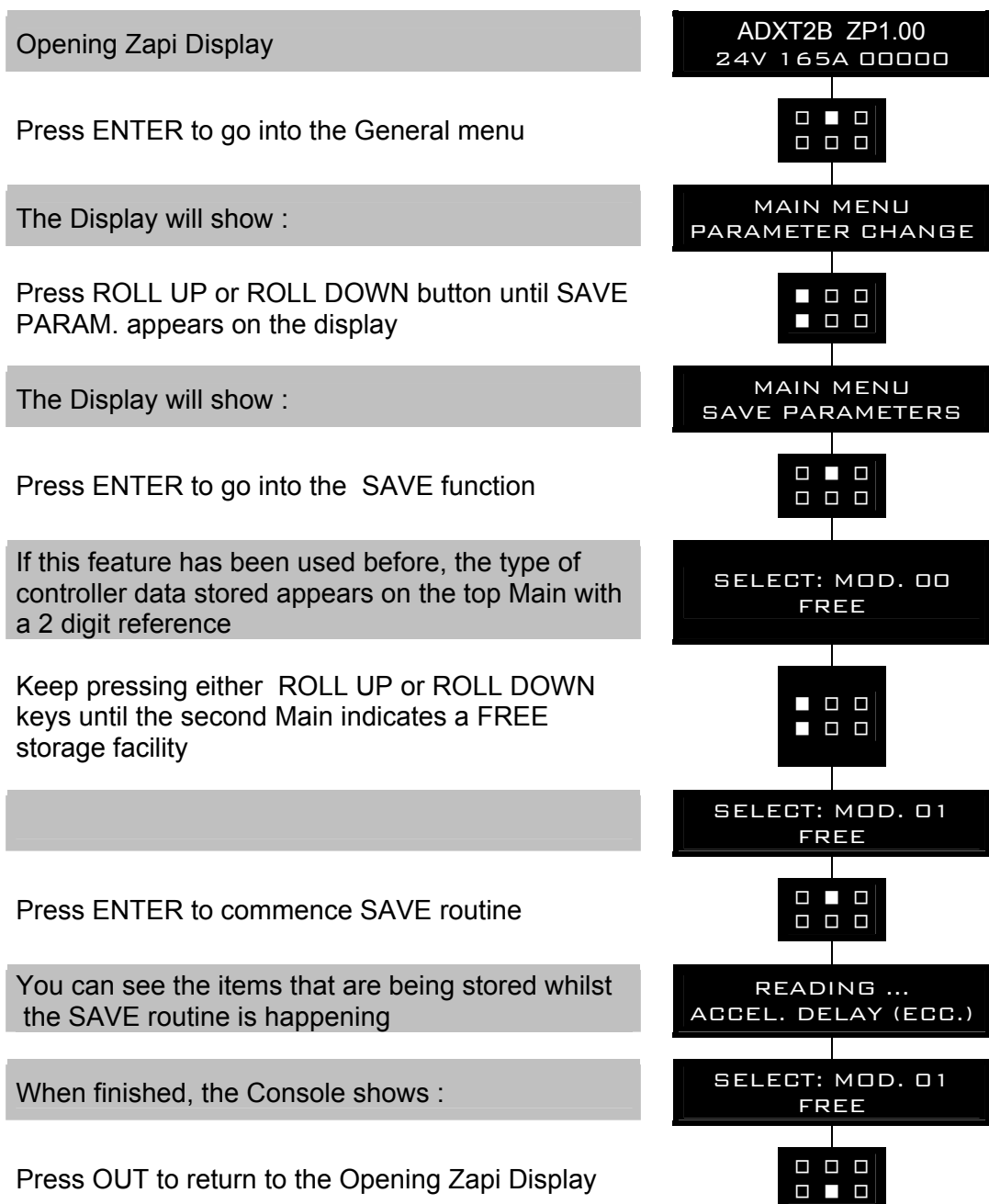



*NOTE: in reality the SAVE and RESTORE function requires the Windows PC-Console.*

## 11.2 Description of console “RESTORE” function

The RESTORE PARAM function allows transfer of the Console’s stored data into the memory of the controller. This is achieved in a fast and easy way using the method previously used with the SAVE PARAM. function.

The data that is available on the RESTORE PARAM. Function are listed here below:

- All Parameter Values (PARAMETER CHANGE).
- Options (SET OPTIONS)
- The level of the Battery (ADJUST BATTERY)

ATTENTION: When the RESTORE operation is made, all data in the controller memory will be written over and replaced with data being restored.

Flow Chart showing how to use the RESTORE function of the Digital Console.

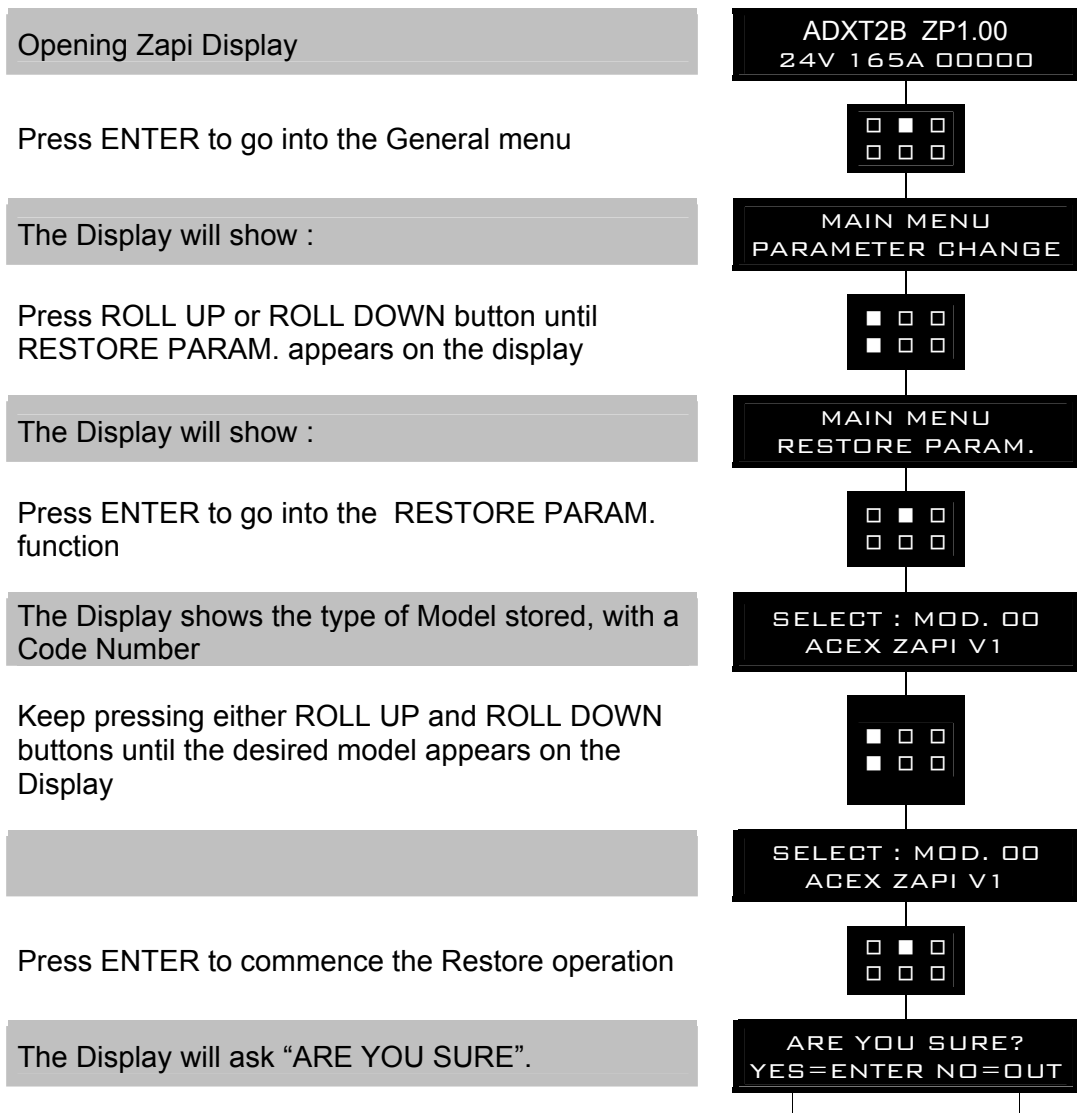

Press ENTER for YES, or OUT for No

You can see the items that are being stored in the chopper memory whilst the RESTORE routine is happening

When finished, the Console shows :

Press OUT to return to the Opening Zapi Display

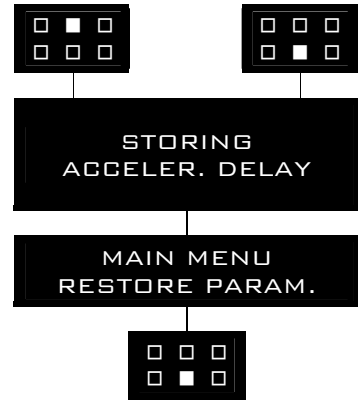

*NOTE: in reality the SAVE and RESTORE function requires the Windows PC-Console.*

### 11.3 Description of console “PROGRAM VACC” function

This enables adjustment of the minimum and maximum useful signal level, in either direction. This function is unique when it is necessary to compensate for asymmetry with the mechanical elements associated with the potentiometer, especially relating to the minimum level.

The two graphs show the output voltage from a non-calibrated potentiometer with respect to the mechanical “zero” of the control lever. MI and MA indicate the point where the direction switches close. 0 represents the mechanical zero of the rotation. The Left Hand graph shows the relationship of the motor voltage without signal acquisition being made. The Right Hand Graph shows the same relationship after signal acquisition of the potentiometer.

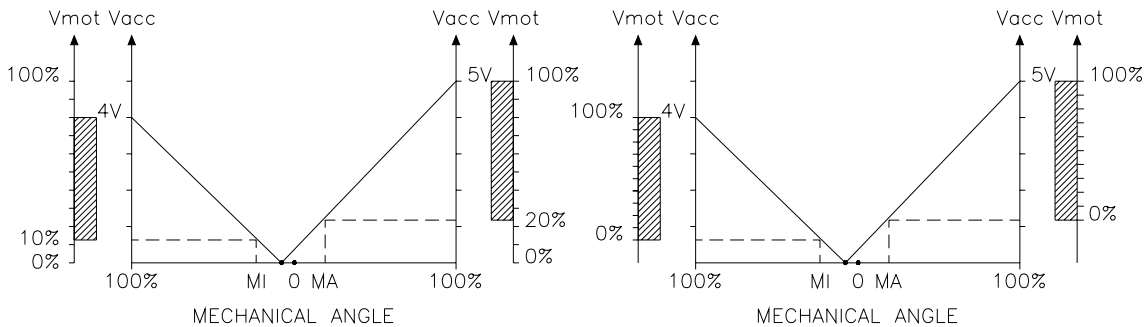

This function looks for and remembers the minimum and maximum potentiometer wiper voltage over the full mechanical range of the pedal. It enables compensation for non symmetry of the mechanical system between directions.

The operation is performed by operating the pedal after entering the PROGRAM VACC function.



Flow Chart showing how to use the PROGRAM VACC function of the Digital Console.

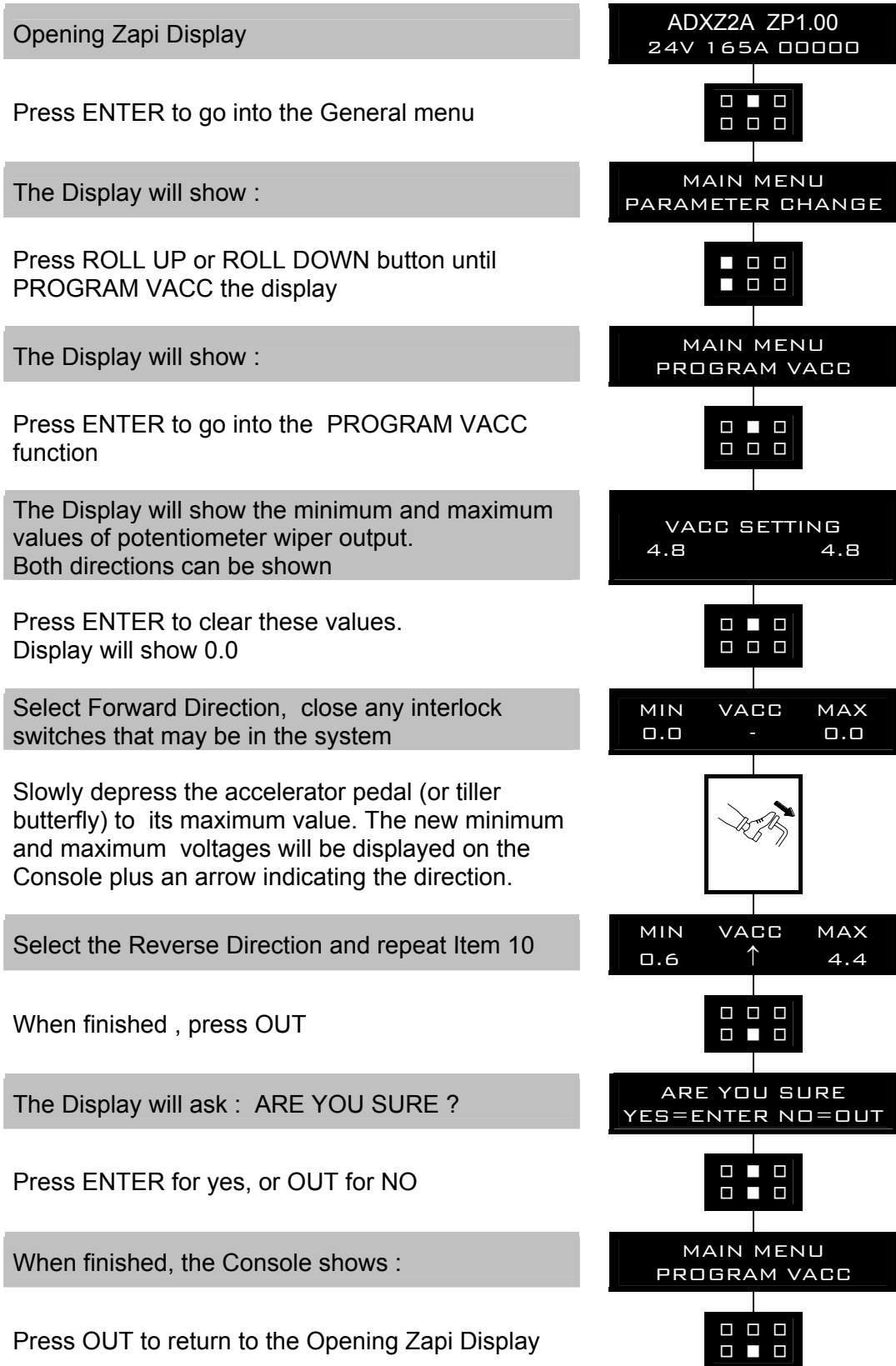

## 11.4 Description of the throttle regulation

This regulation applies a not linear relationship between the position of the accelerator and the speed of the truck. The main goal is to increase the resolution for the speed modulation when the truck is slowly moving.

Three adjustments are used for the throttle regulation:

- 1) THROTTLE 0 ZONE
- 2) THROTTLE X POINT
- 3) THROTTLE Y POINT

**THROTTLE 0 ZONE:** the speed of the truck remains at frequency creep meanwhile the voltage from the accelerator potentiometer is lower than this percentage of the MAX VACC setting. This adjustment define the width of a dead zone close to the neutral position.

**THROTTLE X POINT & THROTTLE Y POINT:** the speed of the truck grows up with a fixed slope (linear relationship) from the THROTTLE 0 ZONE up to THROTTLE X POINT. This slope is defined by the matching between the X point percentage of the MAX VACC setting with the Y point percentage of the full truck speed. From the X point up to the MAX VACC point, the slope of the relationship between the truck speed and the accelerator position is different (see figure below) to match the full speed in the truck with the MAX VACC voltage in the accelerator position.

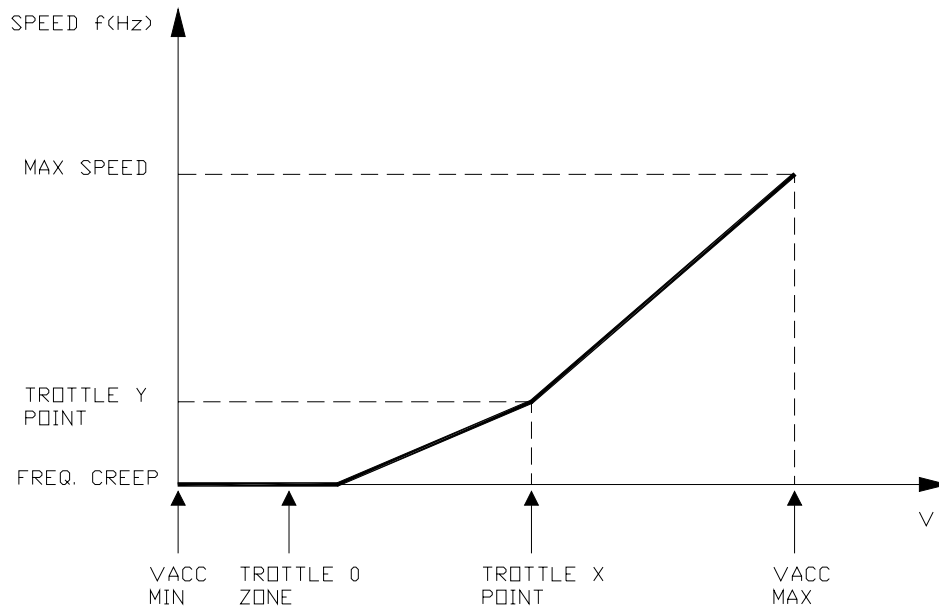

## 11.5 Description of the battery charge detection setting

The Battery Charge detection uses two settings that specify the Full Charge Voltage Level (100%) and the Discharge Voltage Level (10%). These two settings are the Bat.Max.Adj and the Bat.Min.Adj. It is possible to adapt the Battery Charge Detection to your specific battery, by changing the above two settings (e.g. if the Battery Discharged Detection occurs when the battery is not totally discharged, it is necessary to reduce the Bat.Min.Adj setting as indicated in the figure below).

### 48V NOMINAL BATTERY VOLTAGE

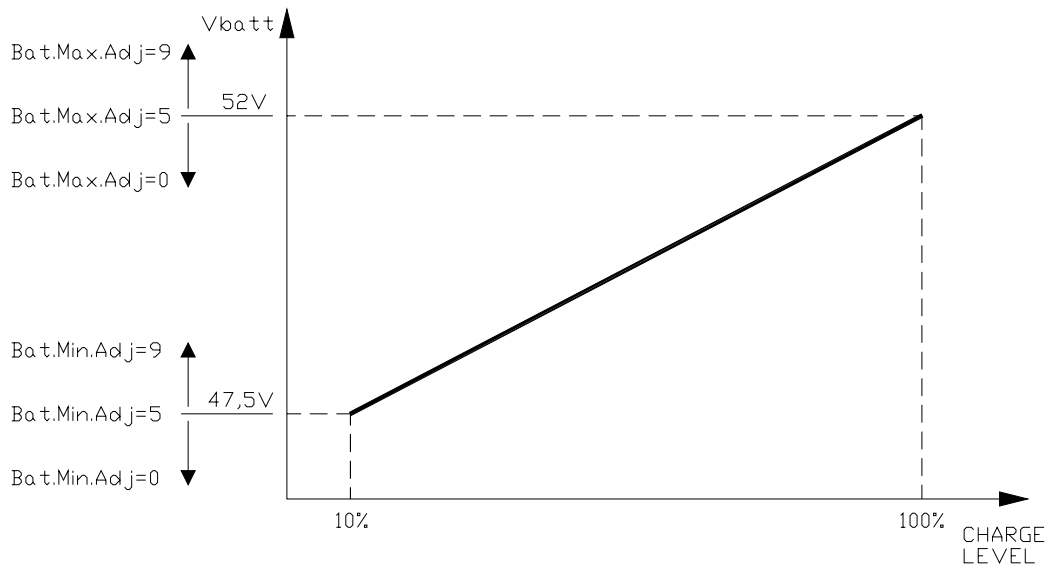

### 24V NOMINAL BATTERY VOLTAGE

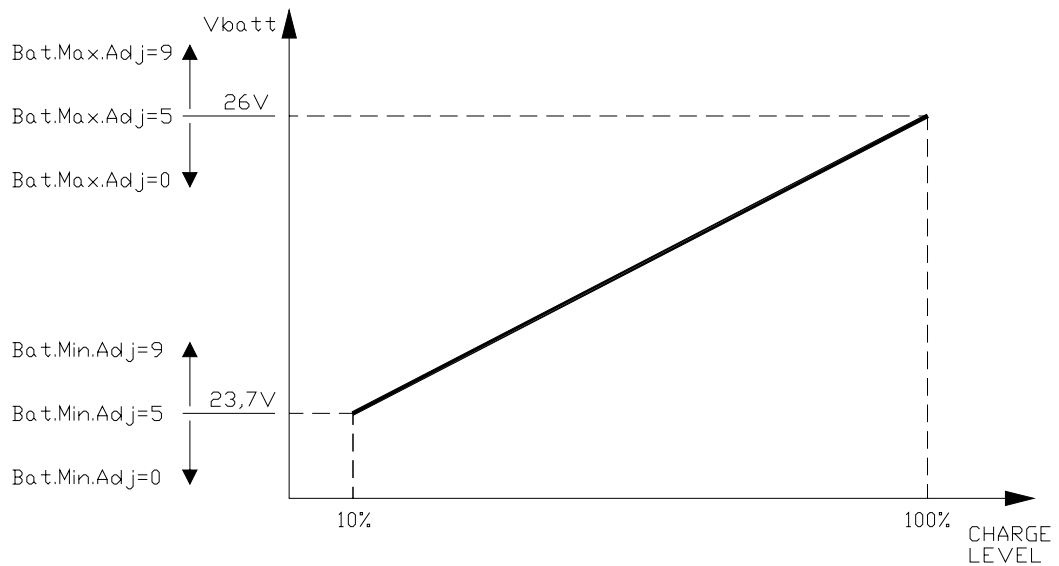

The Battery Charge detection follows this algorithm:

- 1) Battery voltages is read when the Battery current is zero, that is when the output power stage is not driven.
- 2)  $V_{batt}$  is the mean of the least samples measured by the microcontroller converter (the samples are took on key input).
- 3)  $V_{batt}$  is compared with a threshold value (function of the actual charge percentage) in a table and with comparison is found a new charge percentage.
- 4) Thresholds value can be changed with parameters Bat. Max. Adj. and Bat. Min. Adj.
- 5) After key on battery charge can be only increased if the battery charge computed after key on is greater than the last value stored in Eeprom the battery charge value is updated otherwise the Battery charge is not updated.

# 12 COMBIACX / ACEX ALARMS LIST

The ALARMS logbook in the MAIN MENU' records the alarms of the controller. It has a FIFO (First Input First Output) structure that means the oldest alarm is lost when the database is full and a new alarm occurs. The logbook is composed of five locations getting possible to stack five different type of alarms with the following information:

- 1) The alarm code
- 2) The times that each alarm occurs consecutively
- 3) The Hour Meter value when the first event of every alarm occurred
- 4) And the inverter temperature when the first event of every alarm occurred.

This function permits a deeper diagnosis of problems as the recent history can be revised.



**NOTE:** *if the same alarm is continuously happening, the controller does not use new memory of the logbook, but only updates the last memory cell increasing the related counter (point 2) of previous list). Nevertheless, the hourmeter indicated in this memory refers to the first time the alarm occurred. In this way, comparing this hourmeter with the controller hourmeter, it is possible to determine:*

- *When this alarm occurred the first time.*
  - *How many hours are elapsed from the first occurrence to now.*
  - *How many times it has occurred in said period.*
- 

## 12.1 Faults diagnostic system

The fault diagnostic system of COMBIACX / ACEX controller is divided into 2 main groups of faults:

**ALARMS:** these are the faults which open the power section, which means the power bridge is opened and, when possible, the LC is opened and EB is applied.

These are faults related to:

- failures in the motor/controller that the power system is not anymore able to drive the truck
- safety related failures

**WARNINGS:** these are faults which do not stop the truck or stop it by a controlled regen braking. In other words, the controller is working well, but it has detected conditions to reduce the performances or to stop the truck without opening the power devices.

These warnings are related to:

- wrong operator sequences
- conditions which require performance reduction (like high temperatures, ....)

## 12.2 Alarms overview

Error Code	Description	Effect	Machine status when the test is done	Restart procedure
Capacitor charge - MDI CAN 60	Power capacitors voltage does not increase	Valve, pump, traction stopped, Lc opened, Eb applied	start-up	Valve or pump or traction request
Vmn low - MDI CAN 72	Motor output voltage lower than expected	Valve, pump, traction stopped, Lc opened, Eb applied	start-up, traction	Valve or pump or traction request
Vmn high - MDI CAN 31	Motor output voltage higher than expected	Valve, pump, traction stopped, Lc opened, Eb applied	start-up, traction	Valve or pump or traction request
Power mos short - MDI CAN 89	Short circuit on the power mosfets	Valve, pump, traction stopped, Lc opened, Eb applied	start-up	Valve or pump or traction request
Coil short. MC-EB - MDI CAN 76	Shortcircuit on LC or EB coil	Valve, pump, traction stopped, Lc opened, Eb applied	stby, traction	Valve or pump or traction request
Driver shorted MDI CAN 74	Driver of LC coil is shorted, so it is not able to open the LC, or LC coil is disconnected	Valve, pump, traction stopped, Lc opened, Eb applied	start-up	Valve or pump or traction request
Contacteur Driver - MDI CAN 75	Driver of LC coil is damaged (not able to close)	Valve, pump, traction stopped, Lc opened, Eb applied	stby, traction	Valve or pump or traction request
Contacteur Open - MDI CAN 77	The LC coil has been driven but LC does not close	Valve, pump, traction stopped, Lc opened, Eb applied	stby, traction	Valve or pump or traction request
Contacteur closed - MDI CAN 75	LC contact is stuck	Valve, pump, traction stopped, Lc opened, Eb applied	start-up	Valve or pump or traction request
Aux driv. Shrt. MDI CAN 40	When the mos of EB is shorted	Valve, pump, traction stopped, Lc opened, Eb applied	start-up, stby, marcia	Valve or pump or traction request
Aux driver open - MDI CAN 42	Driver of EB coil is damaged (not able to close)	Valve, pump, traction stopped, Lc opened, Eb applied	stby, traction	Valve or pump or traction request
Pos. EB shorted - MDI CAN 86	Output of built in Smart Driver, which supplies Eb coil positive, is high (= +batt) when the tiller switch is opened.	Valve, pump, traction stopped, Lc opened, Eb applied	start-up	Valve or pump or traction request
Logic Failure #1 - MDI CAN 54	Overvoltage/Undervoltage condition has been detected	Valve, pump, traction stopped, Lc opened, Eb applied	start-up	Valve or pump or traction request
Logic Failure #2 - MDI CAN 55	Motor voltage feedback circuits are damaged	Valve, pump, traction stopped, Lc opened, Eb applied	stby, immediately after Lc closing	Valve or pump or traction request
Logic failure #3 - MDI CAN 17	Failure in the high current HW protection circuit	valve, pump, traction stopped, Lc opened, Eb applied	start-up, stby	Valve or pump or traction request
Stby i high - MDI CAN 53	In stby condition (no current applied to the traction motor) the current feedbacks are aout of permitted stby range	Valve, pump, traction stopped, Lc opened, Eb applied	start-up, stby	Valve or pump or traction request
Wrong Battery MDI CAN 41	The battery voltage is too low or too high (< 0,8 Vbatt OR > 1,2 Vbatt)	Valve, pump, traction stopped, Lc opened, Eb applied	start-up, stand-by (only immediately after Lc closing)	Valve or pump or traction request
Analog input - MDI CAN 96	Problem on the A/D conversion of uC	Valve, pump, traction stopped, Lc opened, Eb applied	traction	Valve or pump or traction request
Encoder Error MDI CAN 82	Problem on the encoder	Valve, pump, traction stopped, Lc opened, Eb applied	traction	Valve or pump or traction request
Tiller error - MDI CAN 64	Input mismatch between hard&soft switch input and tiller input	Traction stopped, Eb applied	start-up, stby, traction	Valve or pump or traction request
Watchdog - MDI CAN 08	One of two (or both) Watchdog circuit outputs becomes high due to an HW or SW problem	Valve, pump, traction stopped, Lc opened, Eb applied	start-up, stby, traction	Key re-cycle

Smart driver KO - MDI CAN 68	Smart driver is open, not able to provide EB positive	valve, pump, traction stopped, Lc opened	start-up	Key re-cycle
Key-off shorted - MDI CAN 76	Key-off signal is low at Key-on	valve, pump, traction stopped, Lc opened	start-up	Key re-cycle
Evp driv. short - MDI CAN 50	Evp driver is failed shorted (always ON) mismatch between the valve set-point and its feedback	valve, pump, traction stopped, Lc opened, Eb applied	start-up, stby	valve or pump or traction request
Pump Vmn Low - MDI CAN 28	Pump motor output is too low, with respect to pwm applied	valve, pump, traction stopped, Lc opened, Eb applied	start-up, stby, during pump function	valve or pump or traction request
Pump Vmn High - MDI CAN 29	Pump motor output is too high, with respect to pwm applied	valve, pump, traction stopped, Lc opened, Eb applied	during pump function	valve or pump or traction request
Wrong Zero - MDI CAN code alarm 53	The outputs of the amplifiers (used to measure the motor voltage) are cheked this alarm occurs when voltage signals >3V or <2V at the init	valve, pump, traction stopped, Lc opened, Eb applied	init	valve or pump or traction request
Evp coil open - MDI CAN 50	The Evp1 coil is not connected between PAUX and EVP output, and the parameter EVP TYPE in the set-option menu is set Analog or Digital	valve, pump, traction stopped, Lc opened, Eb applied	start-up, stby, traction	valve or pump or traction request
Aux Batt. Short - MDI CAN code alarm 74	When the positive of the AUX OUTPUT is driven by the tiller, the positive is high and the tiller is released.	valve, pump, traction stopped, Lc opened, Eb applied	start-up, stby	
Pev not OK - MDI CAN code alarm 98	The PEV connector (B2) is not connected to the battery or the voltage is different.	valve stopped, (eventually) pump stopped, (eventually) traction stopped, (eventually) Lc opened and MC applied	continuous	
Flash Checksum - MDI CAN 08	The software is corrupted or the flash on the inverter is damaged.	valve, pump, traction stopped, Lc opened, Eb applied	continuous	
Controller Mism - MDI CAN 12	The software is not compatible with the controller.	valve, pump, traction stopped, Lc opened, Eb applied	start-up	key-recycle
Init vmn low - MDI CAN 72	Motor output voltage lower than expected, before driving the bridge.	valve, pump, traction stopped, Lc opened, Eb applied	start-up	key-recycle
Init vmn high - MDI CAN 31	Motor output voltage higher than expected, before driving the bridge.	valve, pump, traction stopped, Lc opened, Eb applied	start-up	key-recycle
Pump vmn not ok - MDI CAN 32	Pump motor output voltage is different than expected	valve, pump, traction stopped, Lc opened, Eb applied	start-up	key-recycle

## Analysis and troubleshooting of microcontroller alarms

To Enter the MAIN MENU' push the Enter button at the Home Page of the hand set display and Roll for the ALARMS item. Here is the ALARMS list:

### 1) "CAPACITOR CHARGE"

Follows the charging capacitor system:

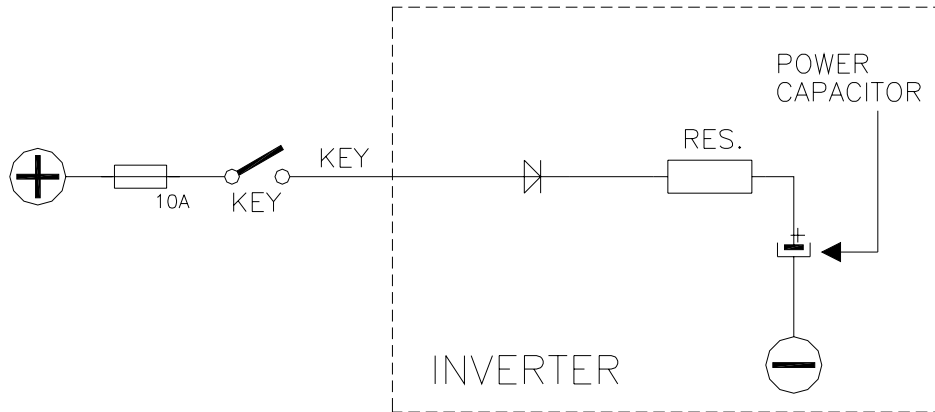

When the key is switched ON, the inverter tries to charge the power capacitors through a power resistance, and check if the capacitor are charged within a timeout. If they do not charge, an alarm is signalled; the main contactor is not closed.

#### Troubleshooting:

- A) There is an external load in parallel to capacitor bank, which sinks current from the controller capacitors precharging circuit, thus preventing the caps from charging. Check if a lamp or a dc/dc converter or a auxiliary load is placed in // to capacitor bank.
- B) The charging resistance is opened; insert a power resistance across line contactor power terminals; if the alarm disappears, it means the controller internal charging resistance is damaged.
- C) The charging circuit has a failure, inside the controller.
- D) There is a problem in the controller power section.

### 2) "VMN LOW"

#### Cause 1: start-up test.

Before switching the LC on, the software checks the power bridge: it turns on alternating the High side Power Mosfets and expects the phases voltage to increase toward the rail capacitor value. If the phases voltage does not increase, this alarm occurs.

#### Cause 2:

Motor running test. When the motor is running, power bridge is ON, the motor voltage feedback is tested; if it is lower than commanded value, fault status is entered.

#### Troubleshooting:

- A) If the problem occurs at start up (the LC does not close at all), check:
  - Motor internal connections (ohmic continuity)
  - Motor power cables connections
  - Motor leakage to truck frame
  - If the motor connections are OK, the problem is inside the controller
- B) If the alarm occurs during motor running, check:
  - Motor connections
  - If motor phases windings/cables have leakages towards truck frame
  - That the LC power contact closer properly, with a good contact



- If no problem are found on the motors, the problem is inside the controller.

### 3) “VMN HIGH”

#### Cause 1:

Before switching the LC on, the software checks the power bridge: it turns on alternating the Low side Power Mosfets and expects the phases voltage to decrease down to -Batt. If the phases voltage do not decrease, this alarm occurs.

#### Cause 2:

This alarm may occur also when the start up diagnosis is overcome, and so the LC is closed. In this condition, the phases' voltages are expected to be lower than 1/2 Vbatt. If it is higher than that value, fault status is entered.

#### Troubleshooting:

- If the problem occurs at start up (the LC does not close at all), check:
  - Motor internal connections (ohmic continuity)
  - Motor power cables connections
  - If the motor connection are OK, the problem is inside the controller
- If the problem occurs after closing the LC (the LC closed and then opens back again), check:
  - Motor connections
  - If motor phases windings/cables have leakages towards truck frame
  - If no problem are found on the motors, the problem is inside the controller

### 4) “POWER MOS SHORT”

Cause: Before switching the LC on, the software checks the power bridge: it turns on alternating the Low side and High side Power Mosfets and expects the phases voltage to decrease down to –BATT (increase up to +Batt). If the phases voltage do not follow the comands, this alarm occurs.

#### Troubleshooting:

This type of fault is not related to external components; replace the controller.

### 5) “COIL SHOR MC-EB”

#### Cause:

This alarm occurs when there is a short circuit of one of the coils connected to outputs of the COMBIACX / ACEX (LC coil or EB coil). After the overload condition has been removed, the alarm exits automatically by releasing and then enabling a travel demand.

#### Troubleshooting:

- The typical root cause for this error code to be displayed is in the harness or in the load coil. So the very first check to carry out concerns connections between controller outputs and loads.
- In case no failures/problems have been found externally, the problem is in the controller, which has to be replaced.

### 6) “DRIVER SHORTED”

#### Cause:

The driver of the main contactor coil is shorted or the coil is disconnected.

#### Troubleshooting:

- Check if there is a short or a low impedance pull-down between NLC CNB#6 and –BATT.
- The driver circuit is damaged in the controller, which has to be replaced.
- The wires to the LC coil are interrupted or not connected, so check the coil related harness.

7) "CONTACTOR DRIVER"

Cause:

The LC coil driver is not able to drive the load. The device itself or its driving circuit is damaged.

Troubleshooting:

This type of fault is not related to external components; replace the controller.

8) "CONTACTOR OPEN"

Cause:

The main contactor coil has been driven by the controller, but the contactor does not close.

Troubleshooting:

It could be also a problem of the contact in the LC that is not working (does not pull-in), try replacing the LC.

9) "CONTACTOR CLOSED"

Cause:

Before driving the LC coil, the controller checks if the contactor is stuck. The controller drives the bridge for some tens milliseconds, trying to discharge the capacitors bank. If they don't discharge the fault condition is entered.

Troubleshooting:

It is suggested to verify the power contacts of LC; to replace the LC is necessary.

10) "AUX DRIV. SHRT."

Cause:

The driver of the electromechanical brake coil is shorted.

Troubleshooting:

- A) Check if there is a short or a low impedance pull-down between NEB CNA#4 and -BATT.
- B) The driver circuit is damaged in the controller, which has to be replaced.

11) "AUX DRIV. OPEN"

Cause:

The driver of the electromechanical brake coil is not able to drive the load.

Troubleshooting:

Replace the controller.

12) "POS EB SHORTED"

Cause:

The output of the built in Smart Driver, which supplies the positive to the Electromechanical brake coil is high when the Tiller and the H&S switch are open.

Troubleshooting:

- A) It is suggested to check the harness, in order to verify if a positive is connected to the Smart driver output CNB#1.
- B) If, even disconnecting the wire from the connector pin, the output stays at high value, the problem is inside the controller and the Smart Driver is probably shorted.

13) "LOGIC FAILURE #1"

This fault is displayed when the controller detects an overvoltage or undervoltage condition. Overvoltage threshold is 35V, undervoltage threshold is 9,5V in the 24V controller. In 36/48V controller overvoltage threshold is 65V,

undervoltage threshold is 9,5V.

Troubleshooting of fault displayed at startup or in standby; in these cases it is very likely the fault is due to an undervoltage, so it is suggested to check:

- A) Key input signal down-going pulses (below undervoltage threshold) due to external loads, like DC/DC converters starting-up, relays or contactor switching, solenoids energizing / de-energizing.
- B) If no voltage transient is detected on the supply line and the alarm is present every time the key is switched ON, the failure is probably in the controller hardware, so it is necessary to replace the controller.

Troubleshooting of fault displayed during motor driving; in this case it can be an undervoltage or a overvoltage condition.

- A) If the alarm happens during traction acceleration or driving hydraulic functions, it is very likely it is an undervoltage condition; check battery charge condition, power cable connection.
- B) If the alarm happens during release braking, it is very likely it is due to overvoltage condition; check line contactor contact, battery power cable connection.

14) "LOGIC FAILURE #2"

Cause:

Fault in the hardware section of the logic board which manages the phase's voltage feedback.

Troubleshooting:

This type of fault is not related to external components, so when it happens it is necessary to replace the Controller.

15) "LOGIC FAILURE #3"

Cause:

Hardware problem in the logic card circuit for high current (overload) protection.

Troubleshooting:

This type of fault is not related to external components, so, when it is present it is necessary to replace the controller.

16) "STBY I HIGH"

Cause:

The current transducer or the current feedback circuit is damaged in the controller.

Troubleshooting:

This type of fault is not related to external components so, when it is present, it is necessary to replace the controller.

17) "WRONG BATTERY"

Cause:

At start-up, the controller checks the battery voltage and verify it is within a window around the nominal value.

Troubleshooting:

- A) Check that the controller SET BATTERY parameter value matches the battery nominal voltage.
- B) Check that the TESTER MENU / BATTERY VOLTAGE parameter shows same value as the battery voltage measured with a voltmeter. If it is does not match, then do a "ADJUST BATTERY" function.
- C) Replace the battery.

18) "ANALOG INPUT"

Cause:

This alarm occurs when the A/D conversion of the analog inputs gives frozen value, on all of the converted signals, for more than 400msec. The goal of this diagnosis is to detect a failure of the A/D converter or a problem in the code flow that omits the refreshing of the analog signal conversion.

Troubleshooting:

If the problem occurs permanently it is necessary to substitute the controller.

19) "ENCODER ERROR"

Cause:

This fault is signalled in following conditions: the frequency supplied to the motor is higher than 40 Hz and the signal feedback from the encoder has a jump higher than 40 Hz in few tens mSec. This condition is related to a malfunctioning of the encoder.

Troubleshooting:

- A) Check both the electric and the mechanical encoder functionality, the wires crimping.
- B) Check the encoder mechanical installation, if the encoder slips inside its compartment raising this alarm condition.
- C) Also the electromagnetic noise on the sensor bearing can be a cause for the alarm. In these cases try to replace the encoder.
- D) If the problem is still present after replacing the encoder, the failure is in the controller.

20) "TILLER ERROR"

Cause:

Mismatch between the H&S input and the tiller input.

Troubleshooting:

Check the harness related to CAN#1 and CAN#29 with a voltmeter. If the state of these inputs is right, then it could be a problem inside the controller, which has to be changed.

21) "WATCHDOG"

Cause:

This is a safety related test. It is a self diagnosis test within the logic. The watch dog circuit is composed by two monostable multivibrators so there is a double check of software execution.

Troubleshooting:

This alarm could be caused by an hardware failure in one of two (or both) multivibrator or due to a software execution problem. For both cases it is an internal fault of the controller which must be replaced.

22) "SMART DRIVER KO"

Cause:

The built in smart driver is open, not able to provide the electro mechanic brake positive.

Troubleshooting:

- A) It is suggested to check the harness, in order to verify if the Smart driver output CNB#1 is shorted to –Batt.
- B) If, even disconnecting the wire from the connector pin, the output stays at low value, the problem is inside the controller and the Smart Driver is probably damaged.

23) "KEYOFF SHORTED"

Cause:

This fault is displayed when the controller detects a low logic level of Key-Off signal during Start-Up diagnosis.

Troubleshooting:

It is very likely the fault is due to an under voltage, so it is suggested to check:

- A) Key input signal down-going pulses (below under voltage threshold) due to external loads, like DC/DC converters starting-up, relays or contactor switching, solenoids energizing / de-energizing.
- B) Check the connection of power cables to the battery terminal, positive and negative, to MC and to controller +Batt and –Batt, which must be screwed with a torque comprised in the range 5,6Nm÷8,4Nm.
- C) If no voltage transient is detected on the supply line and the alarm is present every time the key is switched ON, the failure is probably in the controller hardware, so it is necessary to replace the logic board.

24) “EVP DRIV. SHORT.”

Cause:

- A) The EVP driver is shorted.
- B) The microcontroller detects a mismatch between the valve set-point and the diver voltage measured on the LOWER EVP output.

Troubleshooting:

Check if there is a short or a low impedance between the negative of the coil and -BATT. Otherwise the driver circuit is damaged and the controller must be replaced.

25) “PUMP VMN LOW”

Cause:

The pump motor output is lower than expected, considering the pwm applied.

Troubleshooting:

- A) If the problem occurs at start up (the LC does not close at all), check:
  - Motor internal connections (ohmic continuity)
  - Motor power cables connections
  - If the motor connection are OK, the problem is inside the controller
- B) If the problem occurs after closing the LC (the LC closed and then opens back again), check:
  - Motor connections
  - If motor windings/cables have leakages towards truck frame
  - If no problem are found on the motors, the problem is inside the controller
- C) If the alarm occurs during motor running, check:
  - Motor connections
  - If motor windings/cables have leakages towards truck frame
  - That the LC power contact closer properly, with a good contact
  - If no problem are found on the motors, the problem is inside the controller.

26) “PUMP VMN HIGH”

Cause:

This test is carried out when the pump motor is turning (pwm applied). The pump motor output is higher than expected, considering the pwm applied.

Troubleshooting:

It is suggested to check:

- A) Motor connections
- B) If motor windings/cables have leakages towards truck frame
- C) If no problem are found on the motors, the problem is inside the controller

27) "WRONG ZERO"

Cause:

The outputs of the amplifiers (used to measure the traction motor voltage) are checked to be included into a range . This alarm occurs when the voltage signals >3V or <2V at the init.

Troubleshooting:

This type of fault is not related to external components; replace the controller.

28) "EVP COIL OPEN"

Cause:

This fault appears when the LOWER EVP output is used (parameter "EVP TYPE" in "SET OPTION" menu is set ANALOG or DIGITAL) but no load is connected between the output and PAUX positive.

Troubleshooting:

- A) It is suggested to check the harness, in order to verify if EVP coil is connected to the right connector pin and if it is not interrupted.
- B) If, even connecting the coil to the right pin or replacing it, the alarm is still present than the problem is inside the controller logic board, replace it.

29) "AUX BATT. SHORT"

Cause:

- A) The coil on the aux output is not correctly connected.
- B) The smartdriver inside the controller is damaged.

Troubleshooting:

- It is suggested to check that the coil is correctly connected between B1 and B5.
- If no problem is found on the coil, the problem is inside the controller.

30) "PEV NOT OK"

Cause:

The PEV connector (B2) is not connected to the battery or the voltage is different. This alarm occurs if one output between EV1, EV2, EV3, HORN is present or AUX OUT FUNCTION is PRESENT (if POSITIVE EB= 0 or 2). In other words, one of the output load is connected to PEV.

All the valves (EVP, EV1, EV2, EV3) are stopped. Horn is stopped.

Traction is stopped if the AUXOUT is used for an electrobrake and PEV is indispensable for it (AUX OUT FUNCTION = PRESENT, POSITIVE EB 0 or 2).

Pump is stopped if EV1, EV2 or EV3 are used (PRESENT).

Troubleshooting:

Check B2 connector: it must be connected to the battery voltage (after the main contactor)

31) "FLASH CHECKSUM"

Cause:

The software was not correctly written into the flash memory or the flash memory is damaged.

Troubleshooting:

This type of fault is not related to external components, replace the controller.

32) "INIT VMN LOW"

Cause:

Before switching the LC on, the software checks the power bridge voltage without driving it.

The software expects the voltage to be at a "steady state" value.

If it is too low, this alarm occurs.

Troubleshooting:

Please check

- Motor internal connections (ohmic continuity)
- Motor power cables connections
- Motor leakage to truck frame
- If the motor connections are OK, the problem is inside the controller

33) "INIT VMN HIGH"

Cause:

Before switching the LC on, the software checks the power bridge voltage without driving it.

The software expects the voltage to be at a "steady state" value.

If it is too high, this alarm occurs.

Troubleshooting:

Please check

- Motor internal connections
- Motor power cables connections
- Motor leakage to truck frame
- If the motor connections are OK, the problem is inside the controller

34) "PUMP VMN NOT OK"

Cause:

Before switching the LC on, the software checks the output voltage on –P connector, and expects it to be at a "steady state" value (if TRUCK TYPE options is set to LEVEL=1).

If the voltage is too low, this alarm occurs.

Troubleshooting:

Please check

- The motor connected to –P must be completely still before this alarm occurs. The software waits 30 seconds before showing this alarm. During this time it shows the "WAIT MOTOR STILL" warning (see in the warnings chapter)
- Motor internal connections
- Motor power cables connections
- Motor leakage to truck frame
- If the motor connections are ok, the problem is inside the controller

## 12.3 Warnings overview

Error code	Description	Effect	Machine status when the test is done	Restart procedure
Slip profile - MDI CAN 99	Error on the parameters of the slip profile setting.	Traction is stopped	start-up, stand-by	Traction request
Forw+backward - MDI CAN 80	The travel demands are active in both directions at the same time	Traction is stopped	start-up, stand-by, traction	Traction request
Incorrect start MDI CAN 79	Incorrect starting sequence	Traction is stopped	start-up, stand-by	Traction request
Vacc not ok - MDI CAN 78	The accelerotor value is higher than the minimum value recorded, and the direction/enable switches are opened.	Traction is stopped	start-up, stand-by, traction	Traction request
Th. Protection MDI CAN 62	The controller has reached the thermal cutback temperature 85°C	Traction controller reduces the maximum current linearly from I <sub>max</sub> (85°C) down to 0A (105°C)	continuous	
Battery low	Battery is <= 10% when the parameter BATTERY CHECK is set >0	The maximum current is reduced to half and speed is reduced (if CHECK OPTION = 1)	continuous	
Eeprom ko - MDI CAN 71	Error is detected in eeprom or in eeprom management	Controller works using Deafult parameters	continuous	
Motor temperat - MDI CAN 65	Traction motor temperature sensor is opened (if digital) or has overtaken the threshold of 150°C (if analog)	The maximum current is reduced to half and speed is reduced	continuous	
Thermic sens ko - MDI CAN 61	The output of the controller thermal sensor is out of range.	The maximum current is reduced to half and speed is reduced	continuous	
Check up needed	Maintenance time is reached			
Data acquisition	Maximum current adjustment procedure is in progress (NOTE: this procedure has to be done only by Zapi test department)	Traction is stopped	stand-by	Traction request
Tiller open - MDI CAN 51	The truck is in stby with tiller switch opened for more than 30s	LC opens	standby	Valve or pump or traction request
Current gain - MDI CAN 92	The Maximum current gain parameters are the default values, which means the maximum current adjustment procedure has not been carried out yet	Controller works, but with low maximum current	start-up, stanby	
Waiting for node - MDI CAN 68	A Canbus network node is in alarm condition. uC is waiting for it to resolve its error condition.		continuous	



Error code	Description	Effect	Machine status when the test is done	Restart procedure
Drv. Shor. EV1 dri - MDI CAN 74	EV1 on/off valve drivers shorted (always ON)	On/off valves stopped	start-up, stby	valve on/off request
Drv. Shor. EV2 - MDI CAN 74	EV2 on/off valve driver shorted (always ON)	On/off valves stopped	start-up, stby	valve on/off request
Drv. Shor. EV3 - MDI CAN 74	EV3 on/off valve driver shorted (always ON)	On/off valves stopped	start-up, stby	valve on/off request
Pump I NO zero - MDI CAN 56	Pump chopper current sensor feedback is out of permitted stby range	Pump motor stopped	start-up, stby	pump request
Pump I=0 ever - MDI CAN 52	Pump current feedback is always 0A even when pump motor is running	Pump motor stopped	pump function	pump request
Cont. Drv. Ev1 - MDI CAN 75	Driver of Ev1 is open, not able to close	Ev1 stopped	during Ev1 function	valve Ev1 request
Cont. Drv. Ev2 - MDI CAN 75	Driver of Ev2 is open, not able to close	Ev2 stopped	during Ev2 function	valve Ev2 request
Cont. Drv. Ev3 - MDI CAN 75	Driver of Ev3 is open, not able to close	Ev3 stopped	during Ev3 function	valve Ev3 request
Pump Vacc not OK - MDI CAN 89	The pump accelerator value is higher than the minimum value recorded, and the lift/lower switches are open	Pump stopped	Continuous	Pump request
Sens. Mot. Temp. KO - MDI CAN 67	The motor temperature sensor is damaged	Performance highly reduced	Continuous	Key-on recycle
Vacc out range - MDI CAN 85	The voltage on CNC#4 is out of the parameters range	Traction stopped	Continuous	Program VACC
Stall rotor - MDI CAN 11	The traction rotor is stuck or the encoder is not working	Traction stopped	Continuous	Key-on recycle
EVP driver open - MDI CAN 48	The EVP driver is damaged or the EVP coil impedance is too low	EVP stopped	Continuous	Key-on recycle
Many pump reqs - MDI CAN 49	There are too many pump requests at the same time	Pump stopped	Continuous	Remove request
Pump inc start - MDI CAN 79	Incorrect pump starting sequence	Pump stopped	start-up, stand-by	Pump request
Pump Vacc range - MDI CAN 90	The voltage on CNC#9 is out of the parameters range	Pump stopped, EVP stopped	Continuous	Pump request
Param. Restore - MDI CAN 13	A parameters set restore was made since the last keyoff	No effect	start-up	Traction, pump or EVP request
Wait mot. P. still - MDI CAN 63	The software waits for the motor pump to stop	Valve, pump, traction stopped, LC opened, Eb applied	start-up	None

---

## 12.4 Analysis and troubleshooting of warnings

1) "SLIP PROFILE"

Cause:

There is an error on the choice of the parameters of the slip profile.

Troubleshooting:

Check in the hardware setting menu the value of those parameters.

2) "FORW+BACK"

Cause:

This alarm occurs when both the travel demands (Fwd and Bwd) are active at the same time.

Troubleshooting:

Check the wiring of the Fwd and Rev travel demand inputs (use the readings in the TESTER to facilitate the troubleshooting). Check the microswitches for failures.

A failure in the logic is possible too. So, when you have verified the travel demand switches are fine working and the wiring is right, it is necessary to replace the controller.

3) "INCORRECT START"

Cause:

This is a warning for an incorrect starting sequence.

Troubleshooting:

The possible reasons for this alarm are (use the readings in the TESTER to facilitate the troubleshooting):

A) A travel demand active at key on

B) Presence man sensor active at key on

Check the wirings. Check the micro-switches. It could be also an error sequence made by the operator. A failure in the logic is possible too; so when all of the above conditions were checked and nothing was found, replace the controller.

4) "VACC NOT OK"

Cause:

The test is made at key-on and after 20sec that both the travel demands have been turned off. This alarm occurs if the ACCELERATOR reading in the TESTER menu' is 1,0V higher than PROGRAM VACC min acquisition when the accelerator is released.

Troubleshooting:

Check the mechanical calibration and the functionality of the potentiometer.

5) "TH. PROTECTION"

Cause:

This alarm occurs when the temperature of the base plate is higher than 85°. Then the maximum current decreases proportionally with the temperature increases from 85° up to 105°. At 105° the Current is limited to 0 Amps.

Troubleshooting:

Improve the air cooling of the controller. If the alarm is signalled when the controller is cold, the possible reasons are a thermal sensor failure or a failure in the logic card. In this case, it is necessary to replace the controller.

- 6) "BATTERY LOW"  
Cause:  
It occurs when the battery charge is calculated being less than or equal to 10% of the full charge and the BATTERY CHECK setting is other than 0 (refer to SET OPTION menu).  
Troubleshooting:  
Get the battery charged. If it doesn't work, measure with a voltmeter the battery voltage and compare it with the value in the BATTERY VOLTAGE parameter. If they are different adjust the value of the ADJUST BATTERY function.
- 7) "EEPROM KO"  
Cause:  
It's due to a HW or SW defect of the non-volatile embedded memory supporting the controller parameters. This alarm does not inhibit the machine operations, but the truck will work with the default values.  
Troubleshooting:  
Try to execute a CLEAR EEPROM operation (refer to Console manual). Switch the key off and on to check the result. If the alarm occurs permanently, it is necessary to replace the controller. If the alarm disappears, the previously stored parameters will have been replaced by the default parameters.
- 8) "MOTOR TEMPERATURE"  
Cause:  
This warning occurs when the temperature sensor is opened (if digital) or has overtaken the threshold of 150°C (if analog).  
Troubleshooting:  
Check the thermal sensor inside the motor (use the MOTOR TEMPERATURE reading in the TESTER menu); check the sensor ohmic value and the sensor wiring. If the sensor is OK, improve the air cooling of the motor. If the warning is present when the motor is cool, then the problem is inside the controller.
- 9) "THERMIC SENS. KO"  
Cause:  
The output of the controller thermal sensor is out of range.  
Troubleshooting:  
This type of fault is not related to external components; replace the controller.
- 10) "CHECK UP NEEDED"  
Cause:  
This is just a warning to call for the time programmed maintenance.  
Troubleshooting:  
It is just enough to turn the CHECK UP DONE option to level ON after the maintenance is executed.
- 11) "DATA ACQUISITION"  
Cause:  
Acquisition of the current gains.  
Troubleshooting:  
The alarm ends when the acquisition is done.
- 12) "TILLER OPEN"  
Cause:  
Warning: when the tiller is released, after a fixed period of time of standby (30 seconds) the main contactor open.  
Troubleshooting:

At the next travel request the warning disappear.

13) "CURRENT GAIN"

Cause:

The Maximum current gain parameters are at the default values, which means the maximum current adjustment procedure has not been carried out yet.

Troubleshooting:

Ask the assistance of a Zapi technician to do the correct adjustment procedure of the current gain parameters.

14) "WAITING FOR NODE"

Cause:

The controller receives from the CAN the message that another controller in the net is in fault condition; as a consequence the ACEX / COMBIACX controller itself cannot enter an operative status, but has to WAIT for the other controller coming out from the fault status.

15) "COIL SHOR. EV"

Cause:

One of the electrovalves EV coil is shorted.

Troubleshooting:

Check if there is a short or low impedance between the negative of the EV coil and +BATT. Otherwise the controller is damaged and it must be replaced.

16) "DRV. SHOR. EV1"

Cause:

Electrovalve EV1 driver is shorted.

Troubleshooting:

Check if there is a short or a low impedance between the negative of one of those coils and -BATT. Otherwise the driver circuit is damaged and the controller must be replaced.

17) "DRV. SHOR. EV2"

Cause:

Electrovalve EV2 driver is shorted.

Troubleshooting:

Check if there is a short or a low impedance between the negative of this coil and -BATT. This warning occurs also if the external load is not present and the parameter EV2 in the "Set Options" menu is set "PRESENT", in this case the warning disappears setting the EV2 parameter "ABSENT". Otherwise the driver circuit is damaged and the controller must be replaced.

18) "DRV. SHOR. EV3"

Cause:

Electrovalve EV3 driver is shorted.

Troubleshooting:

Check if there is a short or a low impedance between the negative of this coil and -BATT. This warning occurs also if the external load is not present and the parameter EV3 in the "Set Options" menu is set "PRESENT", in this case the warning disappears setting the EV3 parameter "ABSENT". Otherwise the driver circuit is damaged and the controller must be replaced.

19) "CONT. DRV. EV"

Cause:

One or more on/off valve drivers is not able to drive the load (cannot close).

Troubleshooting:

The device or its driving circuit is damaged, replace the controller.

20) "PUMP I NO ZERO"

Cause:

In standby condition (pump motor not driven), the feedback coming from the current sensor in the pump chopper gives a value out of a permitted range, because the pump current is not zero.

Troubleshooting:

This type of fault is not related to external components; replace the controller.

21) "PUMP I=0 EVER"

Cause:

This test is carried out when the pump motor is running, and it verifies that the current feedback sensor is not constantly stuck to 0.

Troubleshooting:

- A) Check the motor connection, that there is continuity. If the motor connection is opened, the current cannot flow, so the test fails and the error code is displayed.
- B) If everything is ok for what it concerns the motor, the problem could be in the current sensor or in the related circuit.

22) "CONT. DRV. EV1"

Cause:

The EV1 valve driver is not able to drive the load (cannot close).

Troubleshooting:

The device or its driving circuit is damaged, replace the controller.

23) "CONT. DRV. EV2"

Cause:

The EV2 valve driver is not able to drive the load (cannot close).

Troubleshooting:

The device or its driving circuit is damaged, replace the controller.

24) "CONT. DRV. EV3"

Cause:

The EV3 valve driver is not able to drive the load (cannot close).

Troubleshooting:

The device or its driving circuit is damaged, replace the controller.

25) "PUMP VACC NOT OK"

Cause:

The minimum of the lift potentiometer is not correctly set.

Troubleshooting:

It is suggested to repeat a "PROGRAM VACC" procedure.

26) "SENS. MOT. TEMP. KO"

Cause:

- A) The motor temperature sensor is not correctly connected to D3.
- B) The motor temperature sensor is damaged.

Troubleshooting:

- Check the correct connection of the motor temperature sensor.
- If the current sensor is correctly connected, replace it.
- If the problem persist, it is due to the controller.

27) "VACC OUT RANGE"

Cause:

The voltage on CNC#4 is outside of the parameters' range.

Troubleshooting:

Please re-acquire the VACC parameters with a PROGRAM VACC procedure.

28) "STALL ROTOR"

Cause:

The traction rotor is stuck or the encoder signal is not correctly received by the controller.

Troubleshooting:

Please check if the sign of FREQUENCY and ENCODER on the tester menu are the same and different than zero during a traction request.

29) "EVP DRIVER OPEN"

Cause:

The EVP driver is damaged or the EVP coil impedance is too low.

Troubleshooting:

Please check the EVP coil impedance.

If the EVP impedance is OK, the problem is inside the controller.

30) "MANY PUMP REQS"

Cause:

More than one pump functions were requested at the same time.

Troubleshooting:

Just one pump function at a time can be requested. Please reset all the requests and try again.

31) "PUMP INC START"

Cause:

This is a warning for a pump incorrect starting sequence.

Troubleshooting:

The possible reasons for this alarm are:

A) Pump request active at keyon.

B) Pump request active without man presence.

Check the wirings. Check the micro-switches. It could also be an error sequence made by the operator. A failure logic is possible too. When all of the above conditions were checked and nothing was found, replace the controller.

32) "PUMP VACC RANGE"

Cause:

The voltage on CNC#9 is outside of the parameters range.

Troubleshooting:

If the EVP TYPE parameter is set to ANALOG, please acquire again the values of MIN LOWER and MAX LOWER.

If the controller is in Combiacx configuration and the PROPORTION. LIFT parameter is set to ON, please acquire again also the values of MIN LIFT and MAX LIFT.

33) "PARAM RESTORE"

Cause:

This warning appears when the controller restored the default values.

Troubleshooting:

If a CLEAR EEPROM was made before the last keyon-recycle, this warning just means that the EEPROM was correctly cleared. A travel demand or a pump

request cancel the alarm.

If this alarm appears at keyon without any CLEAR EEPROM request by the operator, there could be a problem inside the controller.

34) "WAIT MOT.P. STILL"

Cause:

If TRUCK TYPE option is set to LEVEL = 1, the software expects the voltage on -P output to be at a "steady state" value, before switching the LC on.

If the voltage is different, it could be due to the fact that the motor connected to -P is not still. For this reason, the software waits 30 seconds for the voltage to be at the "steady state" value (and for the pump motor to be still).

After this time, the software assumes that the problem is not due to the fact that the pump motor is not still, and show the "PUMP VMN NOT OK" alarm (see in the alarms chapter).

Troubleshooting:

If the motor connected to -P is still moving, just wait for it to be still.

If not, in 30 seconds the alarm "PUMP VMN NOT OK" will appear. Please see the alarms chapter.

# 13 RECOMMENDED SPARE PARTS

Part number	Description
C29508	SW 180 24V Single Pole Contactor
C29522	SW 180 48V Single Pole Contactor
C12359	Connector Minifit 6 pins Female
C12414	Connector Minifit 8 pins Female
C12500	Connector Minifit 10 pins Female
C12403	Connector Minifit 14 pins Female

Part number	Description	Version
C16604	Protected 100A strip fuse	ACEX 36/48V
C16529	Protected 125A strip fuse	ACEX 24V
C16502	Protected 160A strip fuse	ACEX PW 24/36/48V
C16591	Protected 175A strip UL fuse	
C16504	Protected 300A strip fuse	COMBIACX 24/36/48V
C16587	Protected 300A strip UL fuse	
C16505	Protected 355A strip fuse	COMBIACX PW 24/36/48V
C16588	Protected 350A strip UL fuse	
C16520	10A 20mm control circuit fuse	All



# 14 PERIODIC MAINTENANCE TO BE REPEATED AT TIMES INDICATED

Check the wear and condition of the Contactors' moving and fixed contacts. Electrical Contacts should be checked every **3 months**.

Check the Foot pedal or Tiller microswitch. Using a suitable test meter, confirm that there is no electrical resistance between the contacts by measuring the volt drop between the terminals. Switches should operate with a firm click sound. Microswitches should be checked every **3 months**.

Check the Battery cables, cables to the inverter, and cables to the motor. Ensure the insulation is sound and the connections are tight. Cables should be checked every **3 months**.

Check the mechanical operation of the pedal or tiller. Are the return springs ok. Do the potentiometers wind up to their full or programmed level. Check every **3 months**.

Check the mechanical operation of the Contactor(s). Moving contacts should be free to move without restriction. Check every **3 months**.

Checks should be carried out by qualified personnel and any replacement parts used should be original. Beware of NON ORIGINAL PARTS. The installation of this electronic controller should be made according to the diagrams included in this Manual. Any variations or special requirements should be made after consulting a Zapi Agent. The supplier is not responsible for any problem that arises from wiring methods that differ from information included in this Manual.

During periodic checks, if a technician finds any situation that could cause damage or compromise safety, the matter should be brought to the attention of a Zapi Agent immediately. The Agent will then take the decision regarding operational safety of the machine.

Remember that Battery Powered Machines feel no pain.

**NEVER USE A VEHICLE WITH A FAULTY ELECTRONIC CONTROLLER.**



**IMPORTANT NOTE ABOUT WASTE MANAGEMENT:**

***This controller has both mechanical parts and high-density electronic parts (printed circuit boards and integrated circuits). If not properly handled during waste processing, this material may become a relevant source of pollution. The disposal and recycling of this controller has to follow the local laws for these types of waste materials.***

***Zapi commits itself to update its technology in order to reduce the presence of polluting substances in its product.***

---