

CTI 2500-RIO-A
RS485 REMOTE BASE CONTROLLER
INSTALLATION AND OPERATION GUIDE
Version 2.0

CTI Part # 062-00366-020



**Copyright © 2008 Control Technology Inc.
All rights reserved.**

This manual is published by Control Technology Inc., 5734 Middlebrook Pike, Knoxville, TN 37921. This manual contains references to brand and product names which are trade names, trademarks, and/or registered trademarks of Control Technology Inc. Siemens® and SIMATIC® are registered trademarks of Siemens AG. Other references to brand and product names are trade names, trademarks, and/or registered trademarks of their respective holders.

DOCUMENT DISCLAIMER STATEMENT

Every effort has been made to ensure the accuracy of this document; however, errors do occasionally occur. CTI provides this document on an “as is” basis and assumes no responsibility for direct or consequential damages resulting from the use of this document. This document is provided without express or implied warranty of any kind, including but not limited to the warranties of merchantability or fitness for a particular purpose. This document and the products it references are subject to change without notice. If you have a comment or discover an error, please call us toll-free at 1-800-537-8398 or email us at sales@controltechnology.com.

REVISION HISTORY		
V1.0	03/20/08	Original Issue
	07/25/07	Corrected errors in LED display chart
V2.0	03/20/08	Updated for 2500-RIO-A and redundancy support

PREFACE

This *Installation and Operation Guide* provides reference information for the CTI 2500-RIO-A RS485 Remote Base Controller. The information in this manual is directed to individuals who will be installing the module and configuring it for use with a CTI 2500 Series™ or Simatic® 505 Processor.

We assume you are familiar with the installation and operation of:

2500 Series™ programmable controllers

Please refer to the appropriate SIMATIC® user documentation for specific information on SIMATIC® 505 programmable controllers and I/O modules.

USAGE CONVENTIONS

NOTE:

Notes alert the user to special features or procedures.

CAUTION:

Cautions alert the user to procedures that could damage equipment.

WARNING:

Warnings alert the user to procedures that could damage equipment and endanger the user.

TABLE OF CONTENTS

CHAPTER 1. DESCRIPTION	1
1.1. Introduction	1
1.2. Communication Ports	2
1.2.1. Serial Port	2
1.2.2. I/O Port	2
CHAPTER 2. INSTALLATION	3
2.1. Installation Planning	3
Choosing Remote I/O Media	3
Selecting a Remote Base Address	3
Setting Module Hardware Options	3
Connecting to Remote I/O Cable	3
2.2. Power Requirements	3
2.3. Unpacking the Module	4
2.4. Configuring the Module	4
Setting the RS232 Port Baud Rate	4
Setting Remote Base Controller Station Address	5
Setting the Output State on Communication Loss	5
2.5. Physical Installation	6
2.6. Connecting to the RS232 Port	6
2.7. Connecting the Remote I/O Cable	7
2.8. Operation of LED Display	8
APPENDIX A. REMOTE I/O INSTALLATION GUIDELINES.....	9
Cable Layout Planning	9
Cable Selection	9
Cable Lengths	10
Bus termination	11
Laying Cables Outside of Control Cabinets	12
SPECIFICATIONS	13
General	13
Ports	13
Environmental	13
LIMITED PRODUCT WARRANTY.....	14
REPAIR POLICY	15

CHAPTER 1. DESCRIPTION

1.1. Introduction

The CTI 2500-RIO-A RS485 Remote Base Controller is a member of Control Technology's family of I/O modules compatible with programmable controllers from Siemens® and CTI.

The 2500-RIO-A RS485 Remote Base Controller (RBC) allows a 2500 Series™ I/O base to function as a remote base. The 2500-RIO-A is intended to be a replacement for the Siemens® 505-6851-A RBC. It provides the following functions:

- Compatible with CTI 2500 Series™ and Simatic® 505® CPUs.
- Can be used in currently-available CTI and Siemens® 4, 8, 11, and 16-slot bases
- Supports communication speeds 1Mbits/sec and maximum cable distance of 1000 meters
- LED display which shows error and status codes
- Front panel thumbwheel switch for setting the station address
- On-board RS232 port which can be used for PLC programming and configuration.

The 2500-RIO-A resides in 2500 Series™ base. It installs in the second slot from the left, adjacent to the power supply module. When used in a 2500-R11-A Redundant Base, two 2500-RIO-A units can be installed in the third and fourth slots from the left, adjacent to the second power supply.

Do not install this module into a normal I/O slot, as damage can occur.



Figure 1. 2500-RIO-A Front Panel

1.2. Communication Ports

The 2500-RIO-A RS485 RBC has two communication ports on the front panel.

1.2.1. Serial Port

The RS232 port is provided to interface to PLC programming and configuration tools such as TISOFT™. A standard 9-pin PC-compatible RS232 serial cable is used to connect to the programming device or modem. The port pinout is provided in *Section 2.6* of this manual.

1.2.2. I/O Port

The I/O Port connects the 2500-RIO-A to a SIMATIC® 505 compatible RS485 Remote I/O channel. This enables the remote CPU to control the I/O modules in the base where the RBC is located.

The Remote I/O Port interface is a 9-pin D-Shell connector as detailed in *Section 2.7* of this manual. Recommended guidelines for planning, selection, and installation of Remote I/O system is included in Appendix A.

CHAPTER 2. INSTALLATION

The installation of the Model 2500-RIO-A RS485 Remote Base Controller consists of the following steps:

- 1) Planning the installation
- 2) Verifying power requirements
- 3) Unpacking and configuring the module
- 4) Physical installation
- 5) Connecting cables
- 6) Checking the module operation

2.1. Installation Planning

Choosing Remote I/O Media

The 2500-RIO-A attaches directly to the RS485 Remote I/O cable using a DB9 connector. We recommend using cable designed specifically for RS485 systems, such as Belden 3105A. See Appendix A for information related to cable specifications, layout, and installation.

Selecting a Remote Base Address

Before proceeding, you must determine what address you will assign to the RBC. Remote Base addresses range from 1 to 15. In CTI 2500 Series™ and Simatic® 505® systems, address 0 is reserved for the local base where the CPU is installed. Note that each Remote Base on the Remote I/O channel must have a unique address. If two RBCs are installed in a 2500-R11-A Redundant Base, they must both be set to the same address.

Setting Module Hardware Options

The RBC includes a hardware setting for selecting the state of the base discrete outputs in the event of a loss of communication with the CPU. The module can be configured to set all outputs off, or to leave outputs at their last states. If two RBCs are installed in a 2500-R11-A Redundant Base, they must both have the same configuration.

Connecting to Remote I/O Cable

The Remote I/O connector should be wired as shown in Section 2.7.

2.2. Power Requirements

The CTI 2500-RIO-A module consumes 2.5 watts of +5 VDC power from the backplane. Before installing the RBC, verify that your mounting base power budget can accommodate the required power. A good tool for performing the verification is the CTI Replacement Guide and Power Calculator, available from our website at

<ftp://ftp.controltechnology.com/public/Download/tools/>

2.3. Unpacking the Module

Open the shipping carton and remove the special anti-static bag that contains the module. After discharging any static build-up, remove the module from the static bag. Do not discard the static bag. Always use this bag for protection against static damage when the module is not inserted into the I/O base.

CAUTION:
The components on the 2500-RIO-A module printed circuit card can be damaged by static electricity discharge. To prevent this damage, the module is shipped in a special anti-static bag. Static control precautions should be followed when removing the module from the bag and when handling the printed circuit card during configuration.

2.4. Configuring the Module

There are three steps to configuring the module and making it fully operational:

1. Setting the RS232 Port baud rate
2. Setting the Remote Base Controller address
3. Setting the output state on communication loss (Freeze Jumper)

Figure 2 indicates the location of the RS232 port baud rate selection switches, the RBC station address thumbwheel, and Freeze Jumper. The remainder of this section describes the function of the individual settings.

Setting the RS232 Port Baud Rate

Switches SW1-SW4 are used for setting the baud rate of the RS-232 serial port. The supported baud rates are shown in the following table. All other switch combinations are invalid.

Baud Rate	SW1	SW2	SW3	SW4
19200	1	1	0	1
9600	1	1	1	1
2400	0	1	1	1
1200	1	0	1	1
300	0	0	1	1

Figure 2. Switch Locations

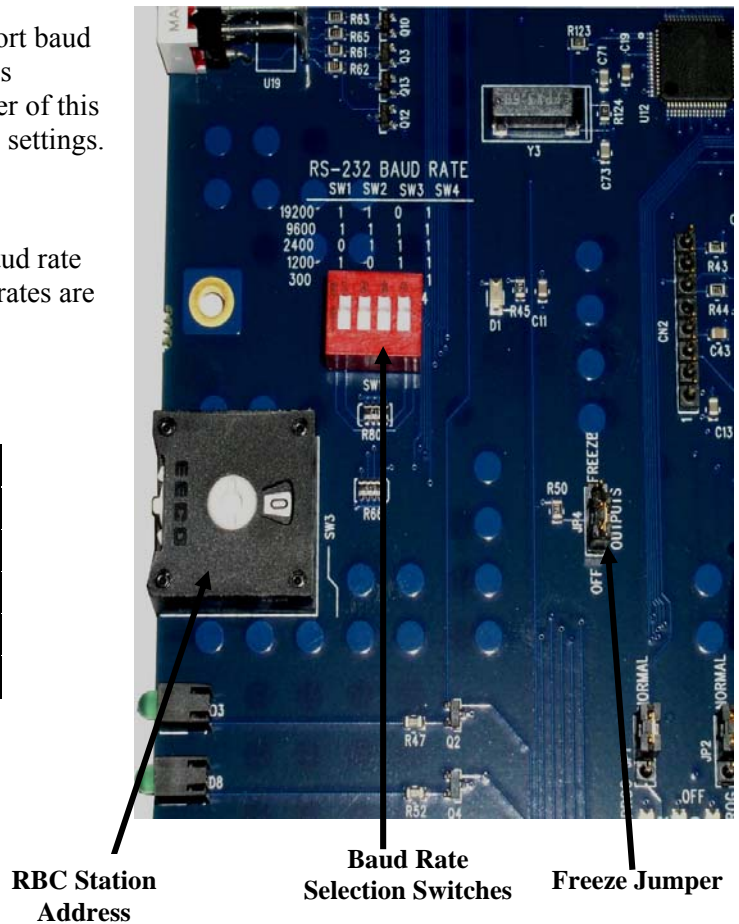

Setting Remote Base Controller Station Address

A thumbwheel switch is provided to set the base address to the 2500-RIO-A for Remote I/O station identification. A maximum of 15 remote bases can be connected to the CTI 2500 Series™ CPU or Siemens® 545/555/575 CPU.

NOTE:

When connecting the 2500-RIO-A to a CTI 2500 Series™ CPU or Siemens® 545/555/575 CPU, only addresses between 1 and 15 are valid. Each installed 2500-RIO-A must have a unique station number.

Care should be taken to prevent circumstances which cause the CPU to lose communication with the 2500-RIO-A while the system is operating. Loss of communication between the CPU and RBC will cause the base to be logged off from the CPU. This can cause intermittent process operation.

WARNING:

The following events will cause loss of communication with the 2500-RIO-A and result in the base being logged off from the CPU.

- 1) Duplication of the station address between RBC's attached to the same CPU (except in dual-media applications).**
- 2) Changing the thumbwheel switch station address while the system is operating.**

These events could cause unpredictable process operation and result in damage to equipment and/or serious injury to personnel.

When a base is logged off, the CPU zeroes all image register input points associated with the base and all outputs go to the value determined by the installed output module. Discrete outputs turn OFF (0) and Analog/Word outputs are set according to the Zero/Hold Last Value settings in each particular module. Your program can monitor the CPU Status Words to detect this condition and control the outputs from other remote bases as appropriate for the application. Details on the Status Words and programming examples can be found in the SIMATIC® 545/555/575 Programming Reference User Manual.

Setting the Output State on Communication Loss

When I/O channel communication to a remote base is lost, the state of the discrete outputs is determined by the selection made on the 2500-RIO-A jumper JP1 (Off/Freeze). Figure 2 shows the location of the jumper on the 2500-RIO-A.

NOTE:

The 2500-RIO-A ships with the FREEZE jumper in the OFF setting. If the jumper JP1 is missing from the board, the 2500-RIO-A defaults to the OFF setting.

For discrete output modules, the state of the outputs is determined solely by the position of the Off/Freeze jumper JP1 on the 2500-RIO-A.

For analog/word output modules, the state of the outputs is influenced not only by the position of the Off/Freeze jumper but by the output module's (Zero/Hold Last Value) selection, if the module has that option. See the table below.

RBC Off/Freeze Selection	Analog/Word Module Zero/Hold Selection	Analog/Word Output State
Off	Zero	Zero*
Off	Hold Last Value	Last Value
Off	No selection	Last Value
Freeze	Zero	Last Value
Freeze	Hold Last Value	Last Value
Freeze	No selection	Last Value

*see the user manual of your analog/word output module for details

Notice that the FREEZE option on the RBC overrides the Zero selection on the analog/word output module; likewise, when Hold Last Value is selected on the analog/word output module, that selection overrides the OFF option on the RBC jumper.

WARNING:
If the RBC fails or loses power during system operation, all outputs will turn OFF(0) regardless of the Freeze Jumper setting. This could result in damage to equipment and/or serious injury to personnel.

2.5. Physical Installation

To insert the module into the I/O base, hold the top and bottom of the bezel and slide the module carefully into the slot, pushing it all the way into the base. If you have inserted the module correctly, you will feel a slight increase in resistance as the module mates with the base backplane connector. Once the module is fully seated in the slot, tighten the captive screws at the top and bottom to hold the module in place. To remove the module from the I/O base, loosen the captive screws, and then pull the module from the base. Take care not to damage the connector at the back of the module when inserting or removing the module.

2.6. Connecting to the RS232 Port

The RS232 port is provided to interface to PLC programming and configuration tools such as TISOFT™. The use of this port is optional. A standard 9-pin PC RS232 serial cable can be used to connect to the programming device or modem. The port details are shown in *Figure 3*. Note that the serial port on the standby unit in a redundant RBC pair is inoperative. This is normal – the CPU makes no attempt to communicate with the serial port of the standby RBC. The standby unit is the one displaying a “C” on the front panel LED display.

9-Pin D-Shell Male Connector
Compatible with standard PC Serial Port

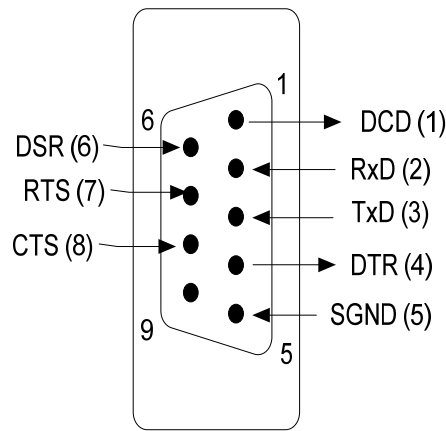

Figure 3. RS232 Serial Port

2.7. Connecting the Remote I/O Cable

The I/O Port connects the 2500-RIO-A to a SIMATIC® 505 compatible RS485 Remote I/O channel. This enables the remote CTI 2500 Series™ or Simatic® 505® CPU to control the I/O modules in the base where the RBC is located.

The Remote I/O Port interface is a 9-pin D-Shell connector with pinout as shown in *Figure 3*. Recommending wiring for the Remote I/O cabling is detailed in Siemens® 545/555/575 System Manual. *Figure 4* shows the pinout for the I/O Port.

9-Pin D-Shell Female Connector

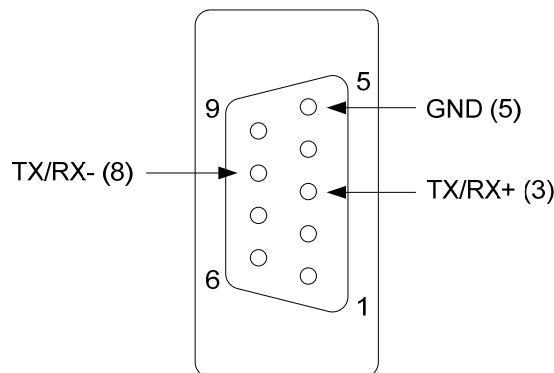

Figure 4. Remote I/O Port

2.8. Operation of LED Display

The LED Display is used to indicate the status of the 2500-RIO-A Remote Base Controller as shown in the following table:

Display	Definition	Communications to RBC	Comment / Action
0	Module Ready	OK	Fully Operational and online with CPU.
1	Diagnostics Failure	None	Serious malfunction. Place system in safe state and contact CTI Technical Support.
2	Module Mismatch	OK	I/O modules installed do not match the expected configuration in the CPU.
3	I/O Communications timeout	Failed	There is no communication with the CPU. Place the system in a safe state. Check power, cabling, and connection to the CPU.
4	Ram Parity Error	Failed	Serious malfunction. Place system in safe state and contact CTI Technical Support.
5	Standby, No Configuration	None	Standby RBC in dual-media application is not configured. Configure module.
6	Address Mismatch	OK	Dual-media RBC's must have identical station address. If addresses are equal, contact CTI Technical Support.
7	Communications OK, No Configuration	OK	2500-RIO-A is not configured. Configure RBC in CPU.
8	Watchdog timeout	Failed	Serious malfunction. Place system in safe state and contact CTI Technical Support.
blank	No Code Displayed	None	Serious condition. 2500-RIO-A is not operational. If power to base is OK, contact CTI Technical Support.
C	Standby unit configured	OK	Standby unit of a redundant pair is configured and communicating

Following power up of a redundant RBC pair, the unit on the left becomes the primary and displays a "0". The unit on the right becomes the standby unit and displays a "C".

APPENDIX A. REMOTE I/O INSTALLATION GUIDELINES

These Remote I/O Installation Guidelines are based on standard RS485 wiring practices. See Chapter 6 of the SIMATIC® 505 545/555/575 System Reference Manual for further details.

The Remote I/O cable system consists of a main trunk line and drop lines which connect the CPU/Local Base and Remote Base(s) to the trunk line by means of terminal blocks as shown in Figure 5.

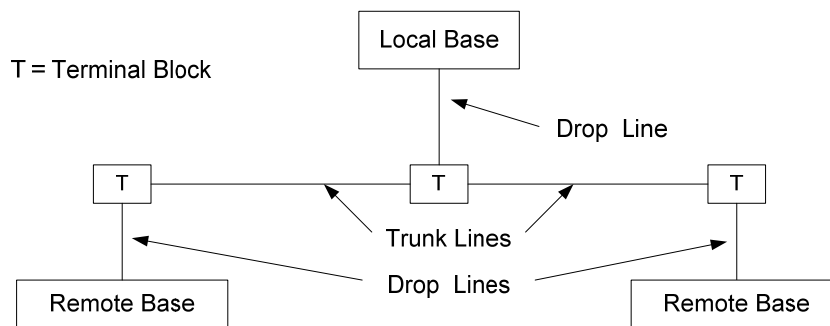

Figure 5. Remote I/O Installation

Cable Layout Planning

Use the following guidelines for planning the Remote I/O cable routing and locations:

- The ideal cable installation is a single, unbranched trunk line with short drop lines and termination resistor at each end
- Maximum length of a drop line should not exceed 33 feet (10 m)
- Drop lines less than 3.3 feet (1 m) do not count toward cable length calculations
- The total length of all drop lines should be much less than the length of the trunk line
- When multiple bases must be located in close proximity, connect all bases in a “daisy-chain” arrangement with a single drop line.

Cable Selection

Data transfer in the Remote I/O systems is based on a symmetrical RS485 bus system using shielded twisted pair cable. The cable shield is used to improve the immunity to electromagnetic interference. The ideal cable provides low signal attenuation for long trunk lines and flexibility for ease of installation. The recommended cable should include the characteristics as shown in the following table.

Cable Characteristic	Recommended	Belden® 3105A
Conductors	18AWG to 22AWG uniform twisted-pair	2-conductors, 22AWG, .030 in (7.5mm), 7x30 stranded
Shielding	100% shield coverage	100% coverage with 90% copper braid plus drain wire
Characteristic Impedance	100 Ω to 150 Ω	120 Ω
Capacitance	< 50 pF/m	11 pF/ft (36 pF/m)
DC Resistance	Resistance of installed length < characteristic impedance	14.7 Ω /1000 ft (48.2 Ω /km)
Attenuation	< 1.0 dB/100 ft (1.0 dB/ 30 m)	0.5 dB/100 ft (0.5 db/30 m) @ 1MHz
Velocity of Propagation	> 65%	78%
Operating Temperature	0 to +60 °C	-20 to +60 °C

Cable Lengths

Maximum permissible cable length is dependent on cable characteristics and number of terminal blocks used in the installation. Terminal blocks are used to connect drop lines and/or extend Remote I/O cable trunk line. The following table contains the maximum recommended cable length (Trunk Length + Drop Lines) for Belden® 3105A cable. It is possible to have longer cable runs if larger diameter wire is used.

Number of Installed Drop Lines	Maximum Cable Length in Feet (Meters)
	Belden 3105A
2-5	2200 (670)
6	2133 (650)
7	2067 (630)
8	2000 (610)
9	1933 (589)
10	1867 (569)
11	1800 (548)
12	1733 (528)
13	1667 (508)
14	1600 (488)
15	1533 (467)
16	1467 (447)
17	1400 (427)

Cable trunk length is measured from the CPU to the most distant base.

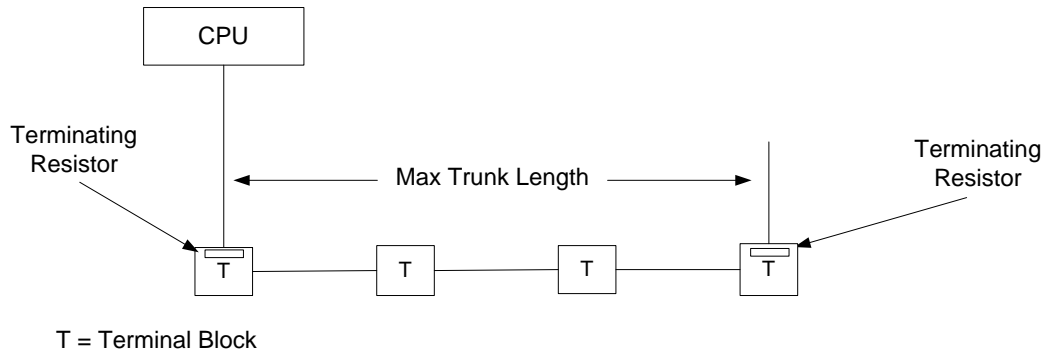

Figure 6. Trunk Length Measurement

By using a T-configuration as shown in *Figure 7*, the maximum trunk length can be extended to twice the length shown in the table on the previous page.

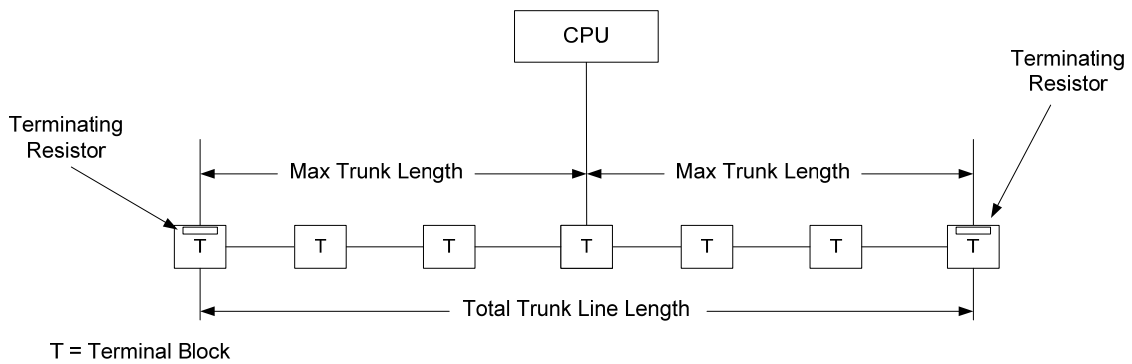

Figure 7. T-Connection Trunk Length

Bus termination

In order to minimize cable reflections and ensure a defined noise level on the data lines, the data transfer cable **MUST** be terminated at both ends with a terminating resistor approximating the characteristic impedance of the cable. For Belden® 3105A cable, a termination resistor value of 120 ohms should be connected across the TX/RX+ and TX/RX- signal lines.

Cable Routing and Layout Guidelines

Cables containing the following	should be routed
Bus signals, e.g. Remote I/O Data signals for PCs, programming devices, printers etc. Screened analog inputs Unscreened DC voltages (<= 60V) Screened process signals (<= 25 V) Unscreened AC voltages (<= 25V) Coaxial cables for monitors	in the same cable loom or cable duct
DC voltages from 60 V to 400 V (unscreened) AC voltages from 25V to 400 V (unscreened)	in separate cable looms or cable ducts without minimum spacing requirements
DC and AC voltages > 400 V (unscreened) Telephone cables For areas with explosion hazard	in separate cable looms or cable ducts without minimum spacing requirements

Laying Cables Outside of Control Cabinets

All cable ducts should be constructed of electrically conducting material and connected to functional ground at regular intervals. Cables should not be subject to mechanical loads which exceed the manufacturer's specifications. If this cannot be avoided, additional protective measures should be taken, such as laying the cables in a steel pipe or rugged metal duct. The pipe or duct should then be grounded at regular intervals and protected against corrosion.

SPECIFICATIONS

General

Module Size: Double-Wide

Backplane Power Consumption: 2.5 watts

Compatibility: CTI 2500 Series™ and Simatic® 505® CPU's
All currently-available CTI and Siemens® 505 4-, 8-, 11-, and 16-slot bases
Single and Dual-Media configurations

Display: Shows RBC status and error codes

Output State Selection: Determines state of outputs when I/O channel communication is lost:

OFF All outputs are turned off
FREEZE All outputs hold their last value

Hardware User Configuration Options:

RS232 Serial Port baud rate (dipswitch)
RBC Station Address (thumbwheel)

Diagnostic Data:

RBC Status Indication in CPU Status Word and Front Panel LED Display

Ports

Remote I/O: 9-Pin D-Shell Female Connector

RS232 Serial: 9-Pin D-Shell Male Connector, PC compatible pinout

Environmental

Operating Temperature: 0° to 60° C (32° to 185° F)

Storage Temperature: -40° to 85° C (-40° to 185° F)

Humidity: 5% to 95%, non-condensing

Agency Approvals Pending: UL, ULC, CE, Class I Division 2 Hazardous Location

Shipping Weight: 1.5 lb. (0.68 Kg)

LIMITED PRODUCT WARRANTY

For product Warranty information, please see our standard product warranty at

<http://www.controltechnology.com/support/warranty/>

REPAIR POLICY

In the event that the Product should fail during or after the warranty period, a Return Material Authorization (RMA) number can be requested orally or in writing from CTI main offices. Whether this equipment is in or out of warranty, a Purchase Order number provided to CTI when requesting the RMA number will aid in expediting the repair process. The RMA number that is issued and your Purchase Order number should be referenced on the returning equipment's shipping documentation. Additionally, if the product is under warranty, proof of purchase date and serial number must accompany the returned equipment. The current repair and/or exchange rates can be obtained by contacting CTI's main office at 1-800-537-8398.

When returning any module to CTI, follow proper static control precautions. Keep the module away from polyethylene products, polystyrene products and all other static producing materials. Packing the module in its original conductive bag is the preferred way to control static problems during shipment. Failure to observe static control precautions may void the warranty. For additional information on static control precautions, contact CTI at 1-800-537-8398.