

---

# ACCLAIM

## ART-4

All rights reserved.

Any improvement and changes to specifications,  
design and this manual, may be made at any time  
without prior notice.

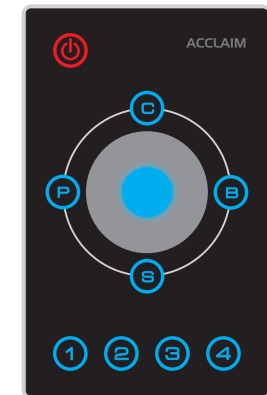

## INSTRUCTIONS MANUAL

Please read this manual carefully and thoroughly before operating this unit.

# CONTENT

Product Description .....	1
Unpacking .....	1
Control Panel and Functions .....	2
Rear Panel View .....	3
Operation Guide .....	4~8
1. ON/OFF .....	4
2. Built-in Program .....	5
3. Brightness .....	5
4. Speed .....	5
5. Color .....	6
5.1 Recording Color .....	6
5.2 Playback Color .....	6
5.3 Setting Fadetime for Color Exchange .....	6
6. SCENE .....	7
6.1 Recording SCENE .....	7
6.2 Playback SCENE .....	7
6.3 SCENE Record Lock/Unlock .....	7
7. Key Tone .....	8
8. Default Setting .....	8
Physical Dimensions .....	9
Technical Specification .....	9

# Physical Dimensions

EU version

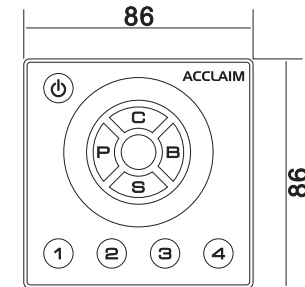

US version

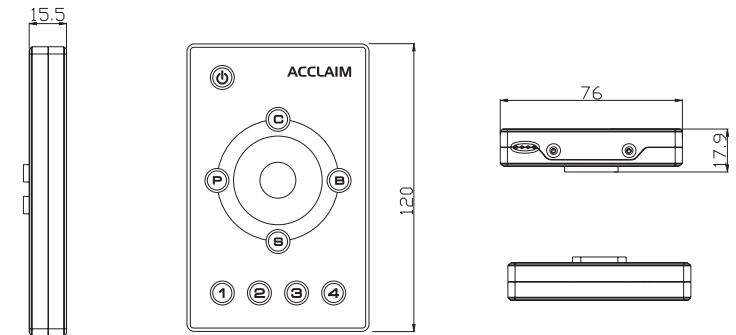

# Technical Specification

Power Supply .....	DC 12-24V
Loading.....	2A per channel, 6A in total
Housing .....	Polycarbonate
DMX out .....	4-pin green terminal
Power in & PWM out .....	6-pin green terminal
Operation Temperature .....	0 degC to +40 degC
Storage Temperature .....	-20 degC to + 70 degC
Weight .....	US 150g / EU 100g
Dimensions .....	EU 86(L) x86(W) x15.5(H)mm US 76(L) x120(W) x15.5(H)mm

---

## Operation Guide

### 7. Key Tone

To turn on or turn off key tone, keep the four figure keys--"1", "2", "3" and "4" touched simultaneously until all keys flash momentarily once to confirm the setting, then release them.

With key tone ON, when you rotate the touch toggle to the maximum or minimum value, the key click disappears.

With key tone OFF, when you rotate the touch toggle to the maximum or minimum value, all keys flash repeatedly 3 times.

### 8. Default Setting

Touch "P" key and "B" key simultaneously and hold on for about 10s until all keys flash once to resume default setting. All the settings by the user are deleted. The fadetime for color change and power ON/OFF is 2 seconds, and the recorded scenes will be replaced by default setting.

---

## Product Description

Thank you for purchasing our digital product ART-4. You now hold a premiere LED controller with DMX 512/PWM output. Its compact and portable design is convenient to mount and easy to operate for users. It's key features consist of as the following:

- Touch interface
- DMX 512/PWM output  
ART-4 uses RGB three channels, 2A per channel, 6A in total.  
Red is controlled by channel 1, 4, 7...  
Green is controlled by channel 2, 5, 8...  
Blue is controlled by channel 3, 6, 9...
- LED indicator to display the current output
- Four function menus
- To record and play back upto 4 scenes and 4 colors
- To set fadetime for Power on/off and color exchange in the range of 0 to 4s
- To assign key tone ON/OFF
- To select input voltage in DC12-24V according to the output loading voltage
- Function memory and power failure protection
- EU and US versions optional

## Unpacking

Check for transport damage.

You should be in possession of the following items:

- 1 ART-4
- 1 User manual

Every ART-4 has been tested at the factory before shipping to you. Please spend a few minutes inspecting the package. Should you discover any transport damage after unpacking the equipment, inform the hauler immediately. Never connect a damaged device. You may also contact your supplier.

## Control Panel and Functions

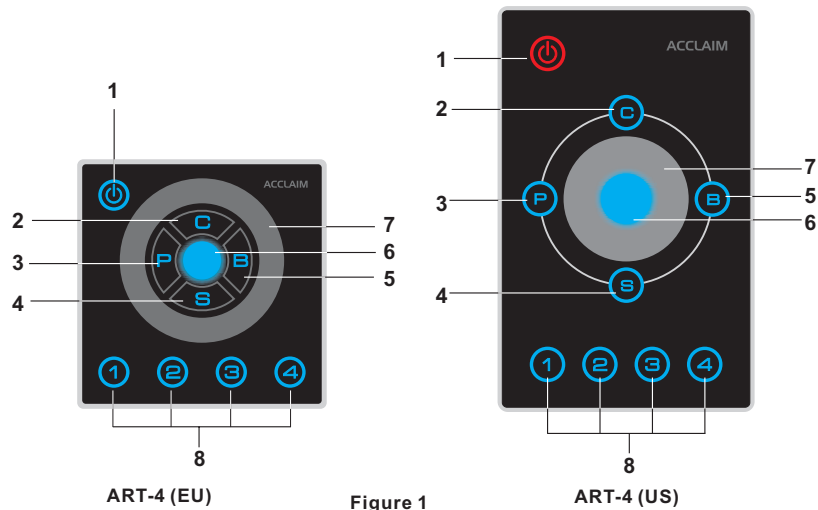

Figure 1

### 1. Power key

Used to power on/off ART-4.

### 2. C key (color)

Used to select color.

### 3. P key (program)

Used to select Built-in program.

### 4. S key (speed)

Used to adjust speed.

### 5. B key (brightness)

Used to adjust brightness.

### 6. Output Indicator

Used to display the current output.

### 7. Touch toggle

Used to adjust color, brightness and speed, and select built-in programs.

### 8. Figure keys (1~4)

Used to record scene and color, as well as set fadetime.

## Operation Guide

### 6. SCENE

#### 6.1 Recording SCENE

Up to 4 scenes can be recorded and played back in this mode. Each figure key corresponds to one scene. The procedure to record a scene is described below:

- Touch "P" or "S" key to enable Auto Mode, the key clicks and the LED indicator lights up.
- Rotate the touch toggle to select the built-in program or adjust the speed.
- Touch any of the figure keys to which you wish to record the scene, and hold on for more than 2 seconds.
- All indicators flash momentarily once to indicate the current parameters (including the built-in program and the value of speed and brightness) have been recorded and saved into the key.
- Repeat step a~d to save more scenes to the other 3 figure keys.

#### 6.2 Playback SCENE

Touch "P" or "S" key to enable Auto Mode. Then touch the corresponding button of 1~4 to raise the scene which has been stored in it. The LED indicator lights up and it starts to display the recorded scene.

#### 6.3 SCENE Record Lock/Unlock

To lock scene record, touch "S" key and "P" key simultaneously and hold on for about 10 seconds. At this time, the "S" key is not valid. Besides, the figure keys 1~4 can play back saved scenes only, but can not record scenes.

To unlock scene record, touch "P" key and "S" key and hold on for about 10 seconds until all keys flash once.

#### \* NOTE:

Each figure key can have a color, or a scene, or both elements recorded.

# Operation Guide

## 5. Color

Touch "C" key to enable Color Menu, the key clicks and the indicator lights up. Then rotate the touch toggle to adjust the RGB value until you get the desired color.

### 5.1 Recording Color

Up to 4 colors can be recorded in manual mode. Each figure key corresponds to one color. The procedure to record a color is described below:

- Touch "C" key to enable Manual Mode, the key clicks and the indicator is lit.
- Rotate the touch toggle to adjust RGB value until you get desired color.
- Touch any of the figure keys to which you wish to record the color, and hold on for more than 2 seconds.
- All indicators flash momentarily once to indicate the current parameters, including the value of color and brightness, have been saved into the key.
- Repeat step a~d to save more colors to the other 3 figure keys.

### 5.2 Playback Color

Touch "C" key to enable Manual Mode. Then touch the corresponding button of 1~4 to raise the color which you've stored in the key. The LED indicator lights up and it starts to display the recorded color.

### 5.3 Setting Fadetime for Color Exchange

To set the fadetime for color exchange, you take the following procedures:

- Touch "C" key and hold on for 5 seconds till all LED indicators flash once. Then release the key and the "C" key flashes repeatedly.
- Touch any one of these keys--1, 2, 3, 4, P, C, B or S.
- All indicators flash momentarily once to confirm the setting.
- The existing mode ends and changes to normal mode automatically.

Different keys represent different fadetime. The table2 details the fadetime information.

Table 2

Keys	1	2	3	4	P/C/B/S
Fadetime	1s	2s	3s	4s	0s (no fade time)

## Rear Panel View

ART-4 features one group DMX OUT with 4-pin terminal connector, one group POWER IN & PWM OUT with 6-pin terminal connector. The configuration of the terminal is as the following (figure 2):

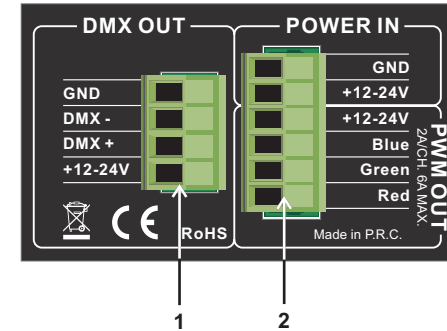

Figure 2

1. DMX OUT: 4-pin terminal

2. PWM OUT & POWER IN: 6-pin terminal

---

# Operation Guide

## 1. ON/OFF

ART-4 can be connected to a DC power at any voltage from 12V to 24V. When the indicator of POWER button lights up, the unit powers on and resumes the output setting of last time.

In normal mode, to touch POWER key and hold on for 2s, ART-4 switches to the state of standby. At this time, the output is shut down. Touch the power key once again and hold on for 2s, the unit is powered on.

### Setting Shortcut for Power ON/OFF

- ▶ Touch "P" key and "Power" key simultaneously and hold on for about 10 seconds until all keys flash momentarily once.
- ▶ Touch "Power" key once, ART-4 changes to standby condition. Directly touch any key on the panel, ART-4 starts up.
- ▶ To delete power shortcut, touch "P" key and "Power" key simultaneously and hold on for about 10 seconds until all keys flash once.

### Setting Fadetime for Power ON/OFF

To set power on/off fadetime, follow the procedures below:

- ▶ Touch "Power" key and hold on for 5 seconds till all LED indicators flash once. Then release the Power key and the key flashes repeatedly.
- ▶ Touch any one of these keys--1, 2, 3, 4, P, C, B or S.
- ▶ All indicators flash momentarily once to confirm the setting.
- ▶ The existing mode ends and changes to normal mode automatically.

Different keys represent different fadetime. The table1 details the fadetime information.

Table 1

Keys	1	2	3	4	P/C/B/S
Fadetime	1s	2s	3s	4s	0s (no fade time)

---

# Operation Guide

## 2. Built-in Program

Press "P" key to enable Built-in Program Menu, the key clicks and the indicator is lit. Then rotate the touch toggle to select a desired built-in pattern. There are 10 built-in programs and Auto Program for user selection ("Auto Program" is the sequential running of these 10 built-in programs).

The process of selecting the built-in programs produces clicks and each click will activate one program.

## 3. Brightness

Touch "B" key to enable Brightness Menu, the key clicks and the indicator lights up. Then rotate the touch toggle to adjust brightness as you wish. In clockwise, the brightness increases; In anti-clockwise, the brightness decreases.

**NOTE:** The value of brightness can be adjusted in the range of 0 to 255.

## 4. Speed

Press "S" key to enable Speed Menu, the key clicks and the indicator lights up. Then rotate the touch toggle to adjust the speed of running built-in programs in the range of 0.2s~10min. In clockwise, the speed will increase; In anti-clockwise, the speed will decrease.

When you rotate the toggle to reach 10min, the click disappears and all the four figure keys flash repeatedly. Then you select the speed which you wish by pressing any of the figure keys. Different figure keys stand for different speed -- "1" for 10min, "2" for 20min, "3" for 30min and "4" for 40min.

**\* NOTE:**

In the process of adjusting brightness and speed, the toggle produces clicks. However, the click disappears when the toggle reaches the maximum /minimum value.