



Intel[®] ICH Family Real Time Clock (RTC) Accuracy and Considerations under Test Conditions

Application Note – AP-728

October 2007



Information in this document is provided in connection with Intel® products. No license, express or implied, by estoppel or otherwise, to any intellectual property rights is granted by this document. Except as provided in Intel's Terms and Conditions of Sale for such products, Intel assumes no liability whatsoever, and Intel disclaims any express or implied warranty, relating to sale and/or use of Intel products including liability or warranties relating to fitness for a particular purpose, merchantability, or infringement of any patent, copyright or other intellectual property right. Intel products are not intended for use in medical, life saving, or life sustaining applications.

Intel may make changes to specifications and product descriptions at any time, without notice.

Designers must not rely on the absence or characteristics of any features or instructions marked "reserved" or "undefined." Intel reserves these for future definition and shall have no responsibility whatsoever for conflicts or incompatibilities arising from future changes to them.

The Intel® ICH family may contain design defects or errors known as errata which may cause the product to deviate from published specifications. Current characterized errata are available on request.

Contact your local Intel sales office or your distributor to obtain the latest specifications and before placing your product order.

Intel and the Intel logo are trademarks or registered trademarks of Intel Corporation or its subsidiaries in the United States and other countries.

*Other names and brands may be claimed as the property of others.

Copyright © 2001–2007 Intel Corporation

Contents

1	Background – External RTC Circuit	5
2	RTC External Battery Connection	8
3	RTC External Circuit.....	10
	3.1 RTC External Capacitor Values	11
	3.2 RTC Signals	12
	3.2.1 Signals on RTCX1 and RTCX2 Pins	12
	3.2.2 VBIAS.....	14
	3.2.3 SUSCLK.....	14
	3.3 RTC Accuracy	14
	3.3.1 RTC Voltage.....	14
	3.3.2 External Capacitance Load	15
	3.3.3 RTC Circuit Layout Considerations	15
	3.3.4 Environmental Conditions	15
	3.4 RTC Accuracy Determination and Frequency Measurement Technique.....	15
	3.4.1 Using Timekeeping Baseline Device.....	15
	3.4.2 Using the Time Interval Analyzer	16
4	Influences Under Environmental Stress	18
5	Optimizations for Stress Testing	20
6	Conclusion.....	22

Figures

1-1	Input and Output of the Intel® ICHn RTC Circuit.....	5
1-2	Intel® ICH1/2/3 RTC External Circuit	5
1-3	Intel® ICH4 RTC External Circuit	6
1-4	Intel® ICH5/6/7/8 RTC External Circuit	6
1-5	Intel® ICH9 RTC External Circuit	7
3-1	External and Internal Circuitry for the RTC Oscillator	10
3-2	Clock Input Connection to X1, X2 Pins When Not Using Internal RTC.....	10
3-3	Example OP-Amp Configuration	13
3-4	Screen-Capture of RTCX1 and RTCX2 Signals on Scope	13
3-5	TIA Menu.....	16



Revision History

Rev.	Draft/Changes	Date
001	<ul style="list-style-type: none">Initial Release	March 2001
002	<ul style="list-style-type: none">General updates	August 2001
003	<ul style="list-style-type: none">ICH4 updates	May 2002
004	<ul style="list-style-type: none">ICH5 updates	June 2003
005	<ul style="list-style-type: none">ICH6 update. Also changed RTCRST# RC for ICH4-6	June 2004
006	<ul style="list-style-type: none">ICH7 update.	April 2005
007	<ul style="list-style-type: none">ICH8 update	May 2006
008	<ul style="list-style-type: none">ICH9 update	October 2007

Background – External RTC Circuit 1

Intel® chipsets using an Intel® ICHn family component use a crystal circuit to generate a low-swing 32 kHz input sine wave. This input is amplified and driven back to the crystal circuit via the RTCX2 signal. Internal to the ICHn (any member of the ICH family), the RTCX1 signal is amplified to drive internal logic as well as generate a free running full swing clock output for system use. This output pin of the ICHn is called SUSCLK. This is illustrated in Figure 1-1.

Figure 1-1. Input and Output of the Intel® ICHn RTC Circuit

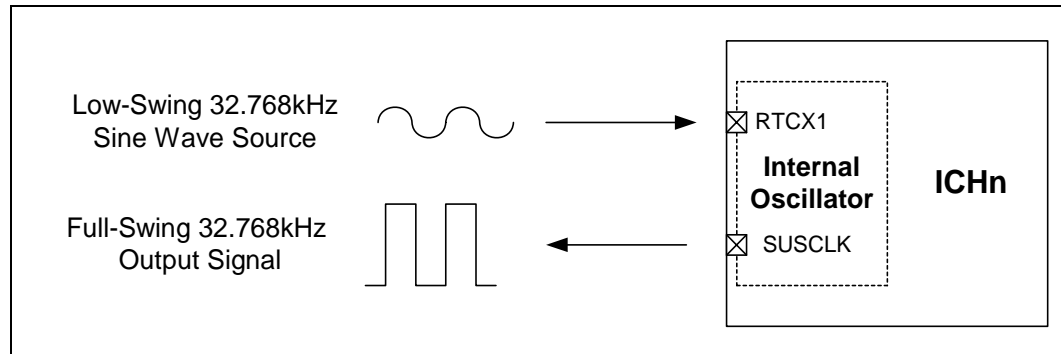

The low-swing 32.768 kHz clock source is generated by a circuit implemented on the motherboard (external to the ICHn component). The schematic is illustrated in Figure 1-2.

Figure 1-2. Intel® ICH1/2/3 RTC External Circuit

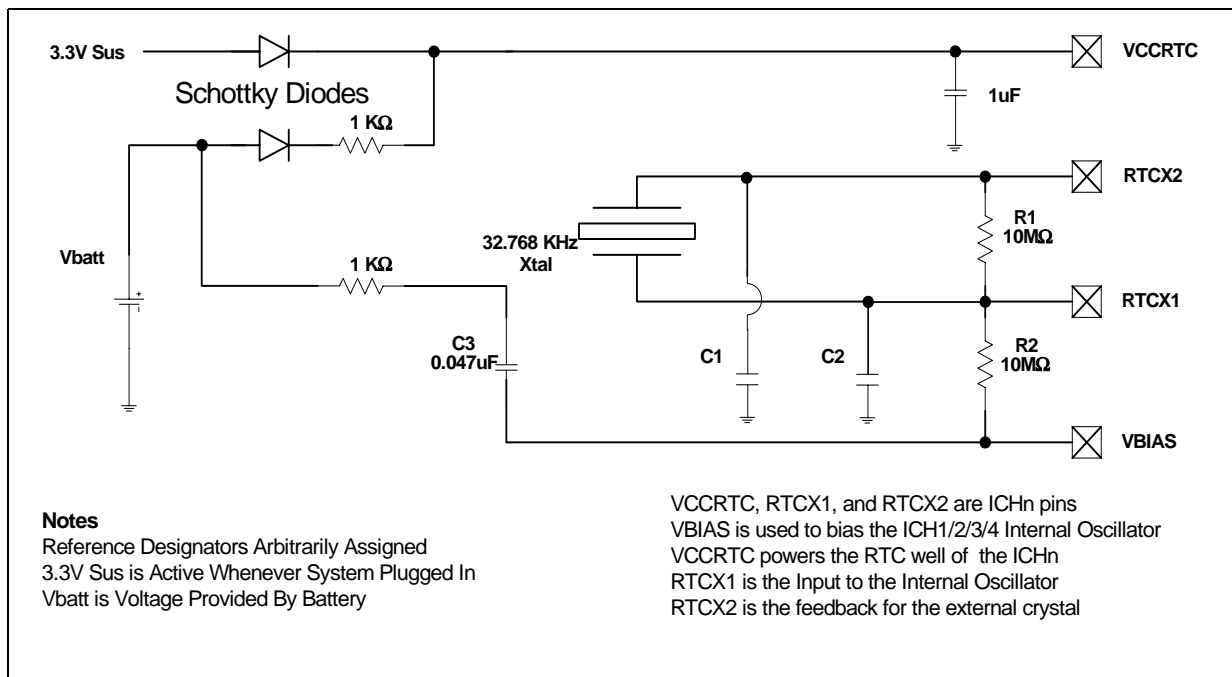

Figure 1-3. Intel® ICH4 RTC External Circuit

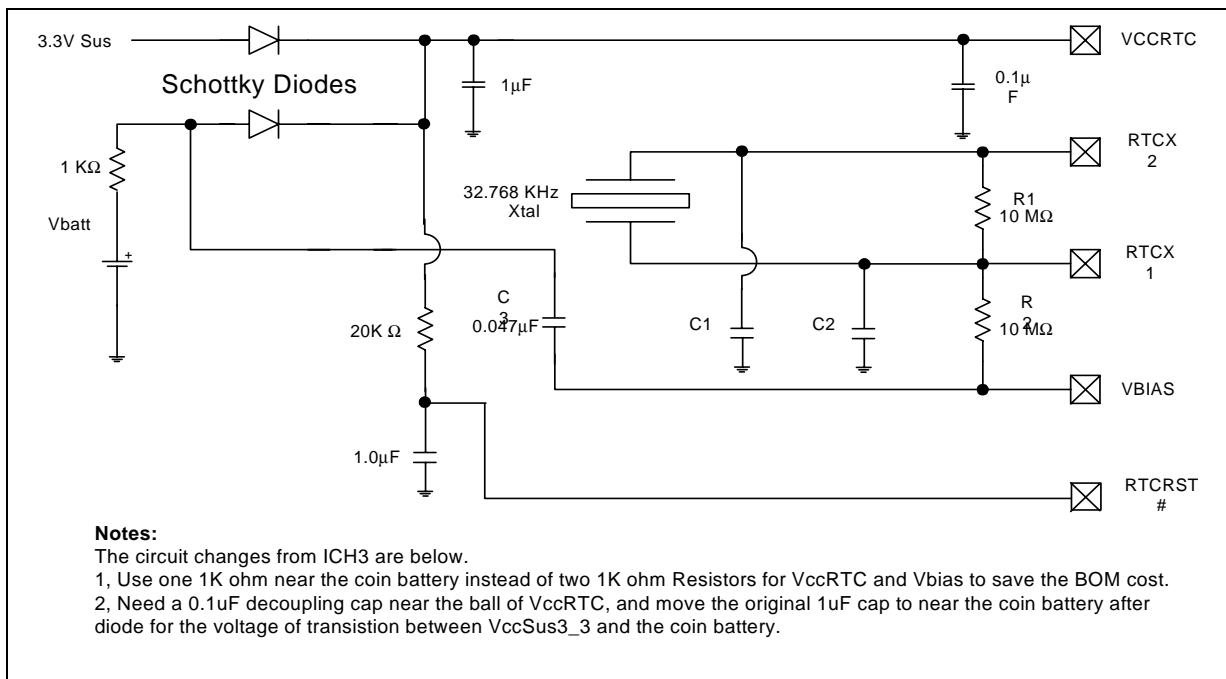

Figure 1-4. Intel® ICH5/6/7/8 RTC External Circuit

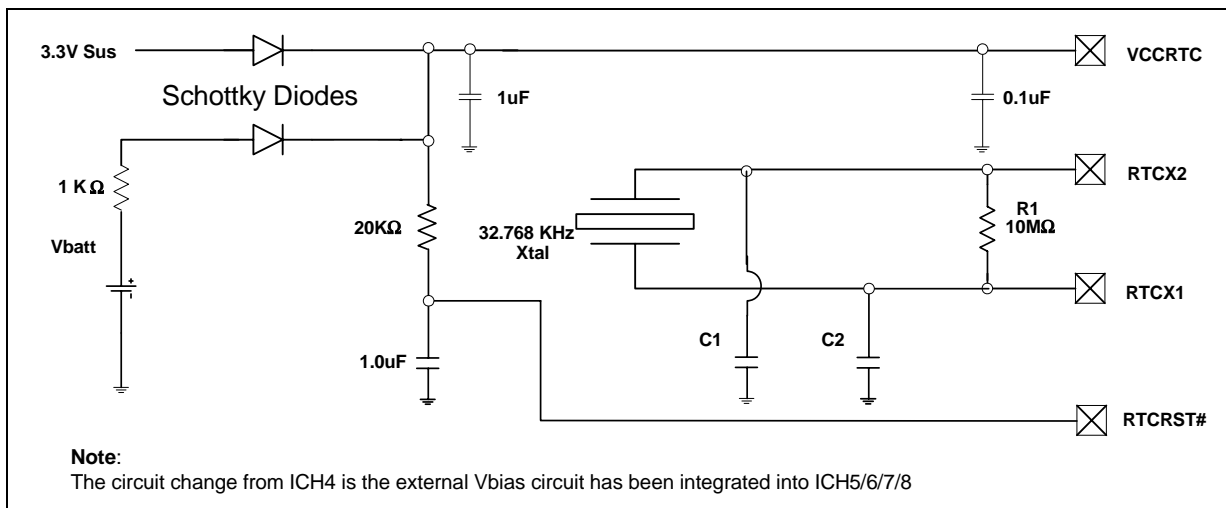
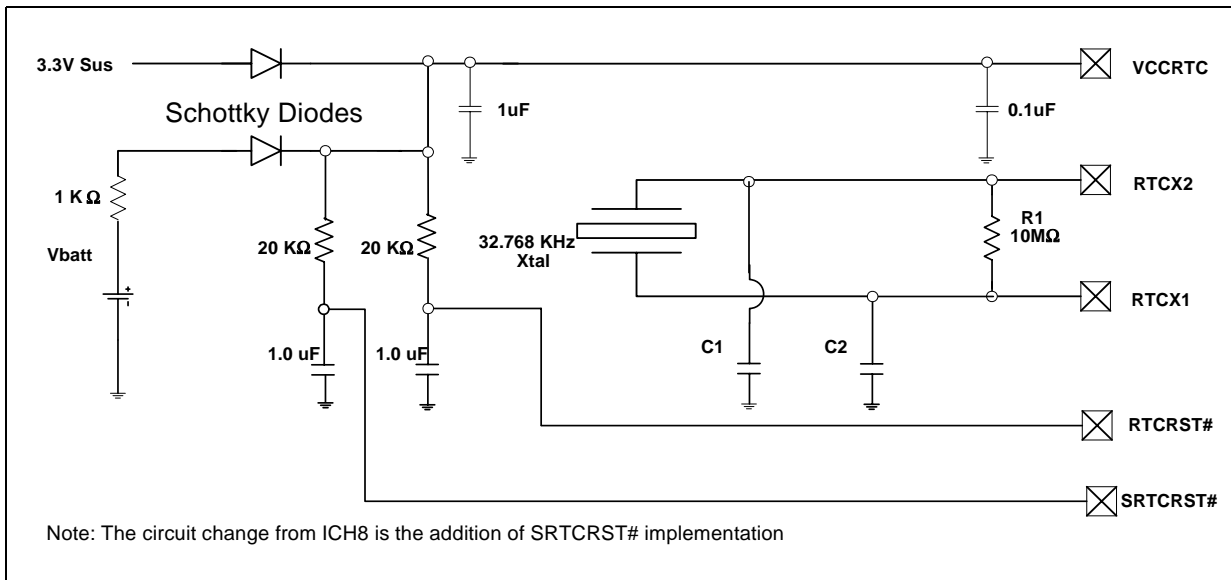

Figure 1-5. Intel® ICH9 RTC External Circuit

The crystal network employs R1, C1, and C2 to generate the 32.768 kHz sine wave. Actual values for these components are dependent on the crystal component specification, trace lengths on the motherboard, and the crystal's load capacitance.

For ICH9, the SRTCST# signal is used to reset the manageability register bits in the RTC well when the on board battery is removed. The external capacitor and the external resistor between SRTCST# and VccRTC are to create an RC time delay, such that SRTCST# will go high some time after the battery voltage is valid. The RC time delay should be in the range of 18 ms – 25 ms.

RTC External Battery Connection

2

The RTC module requires an external battery connection to maintain its functionality and its RAM while the ICHn is not powered by the system.

The recommended batteries are: Duracell 2032, 2025, or 2016, which can give many years of operation.

Batteries are rated by storage capacity. The battery life can be calculated by dividing the capacity by the average current required. For **example**, if the battery storage capacity is 170 mAh (assumed usable) and the average current required is 5 μ A, the battery life will be at least:

$$170,000 \mu\text{Ah} / 5 \mu\text{A} = 34,000 \text{ h} = 3.88 \text{ years.}$$

The voltage of the battery can affect the RTC accuracy. VccRTC must be greater than the min voltage specification at all times to ensure the accuracy of the RTC clock and correctly storing RTC SRAM data. Please refer to specific component datasheet for VccRTC min voltage value.

The battery must be connected to the ICHn via isolation diode circuit. The diode circuit allows the ICHn's RTC-well to be powered by the battery when the system power is not available, but by the system power when it is available. To do this, the diodes are set to be reverse biased when the system power is not available. [Figure 1-2](#), [Figure 1-3](#), and [Figure 1-4](#) have the example of a diode circuitry that is used.

As noted, a standby power supply should be used in desktop and mobile system to provide continuous power to the RTC when available, which will significantly increase the RTC battery life.

§



RTC External Circuit

3

The ICH_n module requires an external oscillating source of 32.768 kHz connected on RTCX1 and RTCX2 pins. Figure 3-1 represents the internal and external circuitry that comprise the oscillator of the RTC.

Figure 3-1. External and Internal Circuitry for the RTC Oscillator

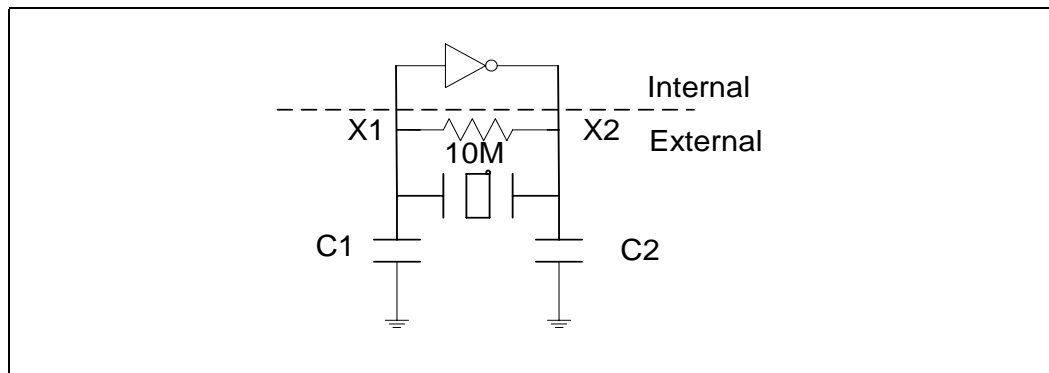

C1, C2 are the required external capacitors that affect the accuracy of the RTC. Choose the right capacitor value for C1 and C2, and the tolerance should be less than or equal to 5%; both are important to maintain RTC accuracy. Section 3.1 presents some guidelines for choosing these values.

Note: Even if the ICH_n internal RTC is not used, it is still necessary to supply clock input to X1 of the ICH_n because other signals are gated off that clock in suspend modes. In this case, an oscillator or a single clock input can be used to drive into X1 with X2 left as no connect; please refer to specific component datasheet for RTC X1 input voltage max value. Figure 3-2 illustrates the connection. However, this is not a validated or supported configuration.

Figure 3-2. Clock Input Connection to X1, X2 Pins When Not Using Internal RTC

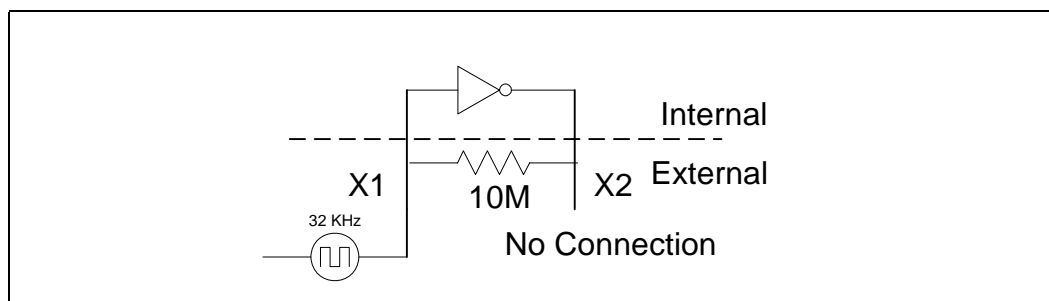

3.1 RTC External Capacitor Values

To maintain the RTC's accuracy, the external capacitor values should be chosen to provide the manufacturer's specified load capacitance (C_{load}) for the crystal when combined with the parasitic capacitance of the circuits traces, socket (if used), package, and ICHn input capacitances. The following equation can be used to choose the external capacitance values:

$$C_{load} = [(C1 + C_{in1} + C_{trace1}) * (C2 + C_{in2} + C_{trace2})] / [(C1 + C_{in1} + C_{trace1} + C2 + C_{in2} + C_{trace2})] + C_{parasitic}$$

Where:

- C_{load} = Crystal's load capacitance. This value can be obtained from Crystal's specification.
- C_{in1} , C_{in2} = input capacitances at RTCX1, RTCX2 pins of the ICHn. These values can be obtained in the ICHn's data sheet.
- C_{trace1} , C_{trace2} = Trace length capacitances measured from the Crystal terminals to RTCX1, RTCX2 pins. These values depend on the characteristics of board material, the width of signal traces and the length of the traces. The typical value of this capacitance is approximately equal to:

$$C_{trace} \approx \text{trace length} * 2 \text{ pF/inch}$$

- $C_{parasitic}$ = Crystal's parasitic capacitance. This capacitance is created by the existence of electrode plates and the dielectric constant of the crystal blank inside the crystal part. Refer to the crystal's specification to obtain this value.

Ideally, C1 and C2 can be chosen such that $C1 = C2$. Using the equation of C_{load} above, the value of C1/C2 can be calculated to give the best accuracy (closest to 32.768 kHz) of the RTC circuit at room temperature. However, C2 can be chosen such that $C2 > C1$. Then C1 can be trimmed to obtain 32.768 kHz.

In certain conditions, both C1/C2 values can be shifted away from the **theoretical values** (calculated values from the above equation) to obtain the closest oscillation frequency to 32.768 kHz. When C1 and C2 values are smaller than the theoretical values, the RTC oscillation frequency will be higher.

The following example will illustrate the use of the practical values for C1 and C2, in the case that theoretical values can not ensure the accuracy of the RTC in a low temperature condition:

Example 1:

According to a required 12 pF load capacitance of a typical crystal that is used with the ICHn, the calculated values of $C1 = C2$ is 18 pF at room temperature (25 °C) to yield a 32.768 kHz oscillation.

At 0 °C the frequency stability of crystal gives -23 ppm (assumed that the circuit has 0 ppm at 25 °C). This makes the RTC circuit oscillate at 32.767246 kHz instead of 32.768 kHz.

If the values of C1 and C2 are chosen to be 6.8 pF instead of 18 pF, this will make the crystal oscillate at a higher frequency at room temperature (+23 ppm) but this configuration of C1 and C2 makes the circuit oscillate closer to 32.768 kHz at 0 °C. The 6.8 pF value of C1 and C2 is the **practical value**.

Note that the temperature dependency of crystal frequency is a parabolic relationship (ppm / degree squared). The effect of the crystal's frequency when operating at 0 °C (25 °C below room temperature) is the same when operating at 50 °C (25 °C above room temperature).

The values of C1 and C2, calculated from the equation above are only the theoretical values. Ideally, these values will be the same as practical values. However, the values of C1 and C2 should be chosen based on the values that give the best accuracy of the RTC circuit. In every specific board design, these practical values may be slightly different from theoretical values.

3.2 RTC Signals

3.2.1 Signals on RTCX1 and RTCX2 Pins

The RTC oscillation signal is a sinusoidal signal that provides a 32.768 kHz frequency to the ICHn. This is a small analog signal with peak-to-peak voltage about 200 mV– 500 mV. The voltage swing on RTCX2 will be slightly larger than the voltage swing on RTCX1, since RTCX2 signal is amplified through the internal inverter of the ICHn.

The RTC circuit oscillates with extremely low bias current ($I_{ccRTC} \leq 5 \mu\text{A}$ —refer to specific component datasheet for I_{ccRTC} maximum value); therefore, this signal is very sensitive to the environmental conditions such as board residue (solder flux, dust), humidity, etc. For example, touching directly on this circuit may cause leakage that can completely attenuate the oscillation signal and make the RTC oscillation stop.

Measuring RTCX1 and RTCX2 is accomplished only by using the following technique to minimize any measurement equipment loading effects.

1. Configure an Analog Devices AD823* (AD823AN) or equivalent Op Amp with very high input impedance (on the order of $10E12 - 10E14$), as a unity gain follower as shown below. Note: This may be different depending on the Op-Amp used. See [Figure 3-3](#) for an illustration.
2. The conductor between the signal being measured and the Op Amp input must be less than 4 mm with a direct connection preferable. The VS+ must be connected to a voltage source that is on all the time, such as an external supply or a 9 V battery.
3. Collect the RTC electrical characteristics:
 - a. Place an oscilloscope probe with sufficient ground reference on the Op-Amp output. The oscilloscope should be configured for 100 mV/DIV and 20 μs /DIV with a trigger set to approximately 200 mV, or until capture is obtained. Record the RTCX1 Vpp. Optional data can be captured such as: DC Offset of RTCX1 and 2 Vpp of RTCX2, DC level for VBIAS, and I_{ccRTC} .

Figure 3-3. Example OP-Amp Configuration

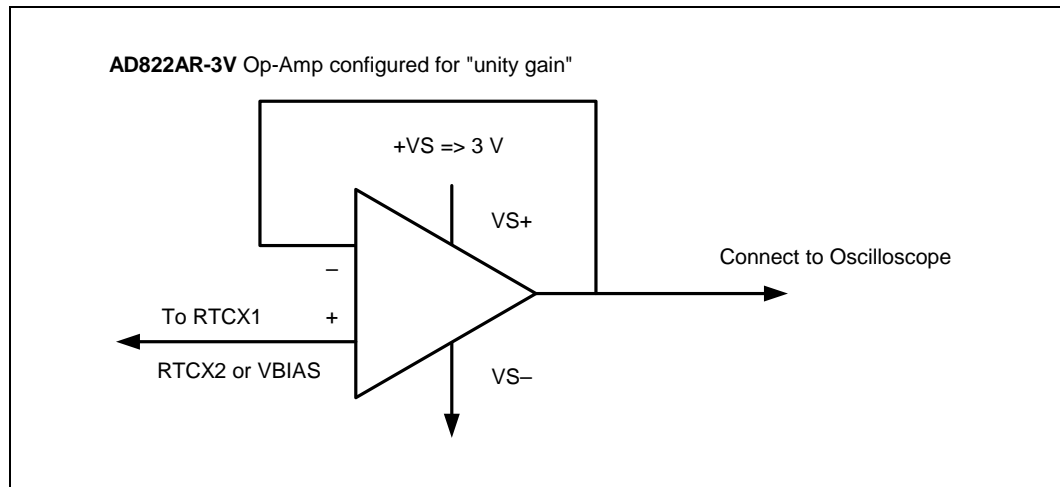
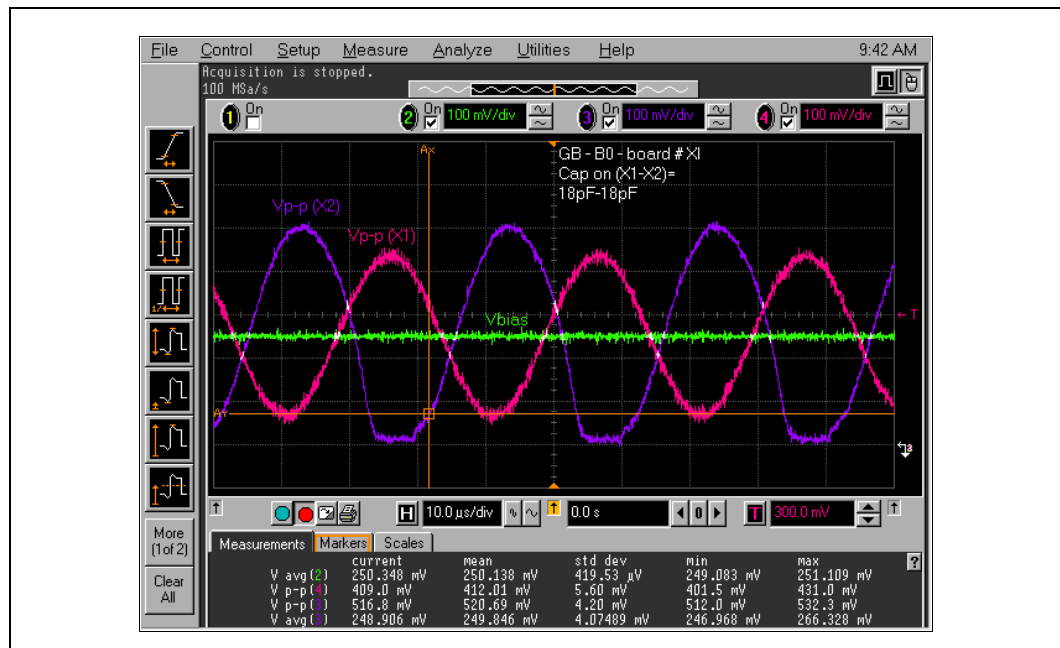

Figure 3-4 shows an example of a screen capture on the RTCX1 and RTCX2 signals:

Figure 3-4. Screen-Capture of RTCX1 and RTCX2 Signals on Scope



3.2.2 VBIAS

ICH5/6/7/8 has integrated the external Vbias circuit. The external Vbias circuit is only required for ICH1/2/3/4.

For ICH1/2/3/4, VBIAS is a DC voltage level that is necessary for biasing the RTC oscillator circuit. This DC voltage level is filtered out from the RTC oscillation signal by the RC network of R2 and C3 (see [Figure 1-2](#) and [Figure 1-3](#)). Therefore, it is a self-adjusted voltage. Board designers should not manually bias the voltage level on VBIAS. Checking the VBIAS voltage level is used for testing purposes only to determine the right bias condition of the RTC circuit.

VBIAS should be at least 200 mV DC on ICH1/2/3/4. The RC network of R2 and C3 will filter out most of AC signal that exist on this pin, however, the noise on this pin should be kept minimal in order to ensure the stability of the RTC oscillation.

Probing VBIAS requires the same technique as probing the RTCX1, RTCX2 signals (using Op-Amp)

VBIAS is also very sensitive to environmental conditions.

3.2.3 SUSCLK

SUSCLK is a square wave-form signal output from the RTC oscillation circuit. Depending on the quality of the oscillation signal on RTCX1 (largest voltage swing), SUSCLK duty cycle can be between 30-70%. If the SUSCLK duty cycle is beyond 30%–70% range, it indicates a poor oscillation signal on RTCX1 and RTCX2.

SUSCLK can be probed directly using a normal probe (50 Ω input impedance probe) and is the appropriate signal to check the RTC frequency to determine the accuracy of the ICHn's RTC Clock (see [Section 3.4.2](#) for details).

3.3 RTC Accuracy

This ICHn RTC circuit is a low current circuit designed to provide accurate time keeping service, at an extremely low current consumption (I_{ccRTC}) a maximum of 5 or 6 μA (please refer to specific component datasheet for I_{ccRTC} max value). As a result, this circuit is subject to adverse influences, which must be addressed or understood to ensure the best possible RTC accuracy.

The RTC accuracy can be affected by the following primary factors:

3.3.1 RTC Voltage

The RTC accuracy can be affected by the voltage of battery. In general, when the battery voltage decays, the RTC accuracy also decreases. High accuracy (less than ± 10 ppm which does not include Crystal's tolerance) can be obtained when V_{ccRTC} is larger than the min voltage specification. For example: 20 ppm is equivalent with 1.728 sec error in one day.

$$\begin{aligned} \text{PPM} &= ((F_o - 32.7680) / 32.768) * 10^6 \\ 1 \text{ day} &= 24 \text{ hours/day} * 60 \text{ min/hour} * 60 \text{ sec/min} = 86400 \text{ sec} \\ 20 \text{ ppm} * 1 \text{ day} (86400 \text{ sec}) &= (20 * 86400) / 1000000 = 1.728 \text{ sec} \end{aligned}$$

3.3.2 External Capacitance Load

The external capacitance load values are combined with the external capacitor values, the capacitance of the circuit's trace, socket, and package. These values should be matched to the actual load capacitance required of the crystal used for the RTC accuracy. Refer to [Section 3.1](#) for guidelines to calculate the external capacitance.

3.3.3 RTC Circuit Layout Considerations

Since the RTC circuit is very sensitive and requires high accuracy oscillations, reasonable care must be taken during the layout and routing of the RTC circuit. Some recommendations are:

- Reduce trace capacitance by minimizing the RTC trace length. ICHn requires a trace length less than 1 inch on each branch (from crystal's terminal to RTCXn pin). Routing the RTC circuit should be kept simple to reduce the trace length measurement and increase accuracy on calculating trace capacitances. Trace capacitance depends on the trace width and dielectric constant of board's material. On FR-4, a 5-mil trace has approximately 2 pF per inch.
- Trace signal coupling must be reduced. Avoid routing PCI signals or noisy periodic signals close and parallel to RTCX1, RTCX2, and VBIAS.
- Ground referencing is highly recommended.

3.3.4 Environmental Conditions

The crystal temperature itself will impact the RTC accuracy. The deviation from room temperature will reduce the RTC accuracy unless this factor is compensated by using the practical configuration of C1, C2 value (See [Section 3.1](#) for details).

Condensation from humidity can also affect the RTC accuracy due to leakage on RTC signals (see [Section 3.2](#) for details).

Note: The heat will damage the Crystal when reworking the boards. Follow the specification of Crystal to set the right temperature for operation.

3.4 RTC Accuracy Determination and Frequency Measurement Technique

The accuracy of RTC clock can be determined by many different methods. Two common methods for checking RTC accuracy are:

- Using timekeeping-baseline-device (via BIOS and system NVRAM)
- Using Time-Interval-Analyzer on SUSCLK signal

3.4.1 Using Timekeeping Baseline Device

Accuracy of the baseline device is crucial to determining RTC accuracy. The use of a watch or clock is not sufficiently accurate for 25 ppm range accuracy over the periods used during these tests. It is required that a Global Positioning System device (GPS) be used instead. A GPS contains a clock that is reset at acquisition time to an extremely accurate time. Over time though, the GPS

time will drift like any other clock. For this reason the GPS should be reset, powered on outside and allowed to synchronize, within 15 minutes of either setting time on motherboard or using it for a standard readout.

3.4.2 Using the Time Interval Analyzer

Using an Agilent-TIA (Time Interval Analyzer) is a very accurate way of measuring the RTC frequency. This tool can measure the 32.768 kHz frequency of the RTC with a tolerance typically less than ± 20 mHz (mili-Hertz).

It is ideal to use this equipment to determine the configurations of the fork tuning capacitors C1 and C2 which are described in [Section 3.1](#). This is to get the most accurate frequency on the RTC circuit.

The following is a description of how to use an Agilent-TIA to calculate the frequency of the RTC circuit:

1. The frequency of RTC oscillator can be monitored on the SUSCLK signal of the ICHn. Locate SUSCLK signal on the board and connect this signal to the probe of Agilent-TIA with a properly connected ground pin.
2. Run the Agilent-E1743A program. Target frequency should be set to 32.768 kHz.(Refer to Agilent-TIA user manual for more information on how to setup the equipment.)
3. On TIA menu, click on “Measure/View Setup,” the setup dialog box will appear as shown in [Section 3-5](#)

Figure 3-5. TIA Menu

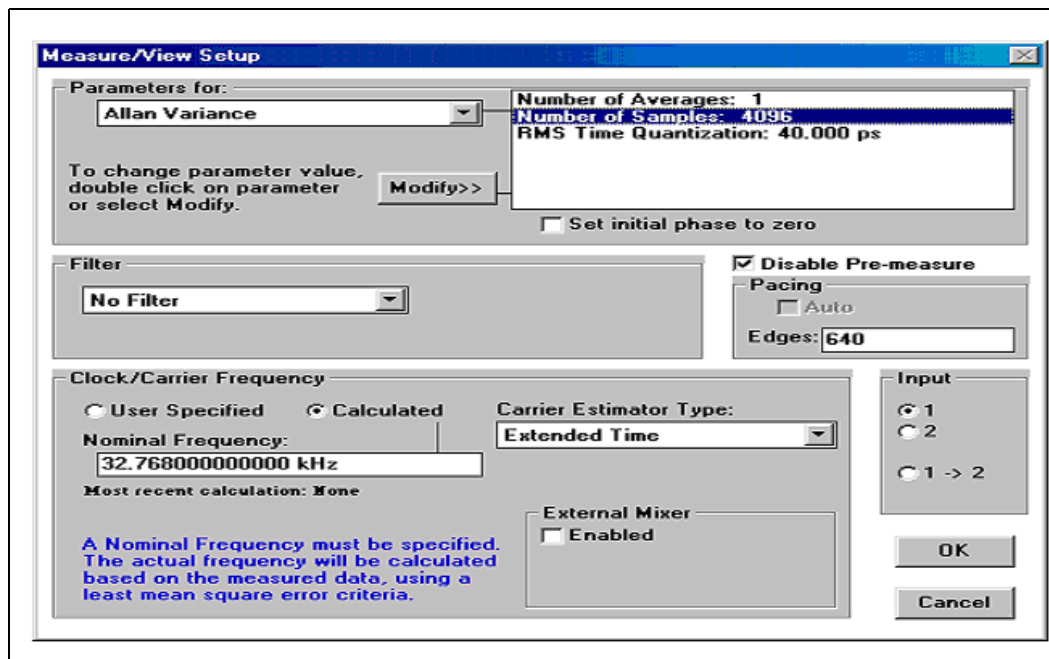

The pacing number is the number of clock edges that the TIA will count before it capture for each time stamp. Depending on the TIA memory size, the number of samples varies (1024, 4096, etc.), chose the largest number possible. The measured frequency (F_0) will be calculated based upon the average period of all samples. This is the frequency of the RTC clock. The following formula is used to calculate the PPM:

$$\text{PPM} = [|(F_0 - 32.768 \text{ kHz})| / (32.768 \text{ kHz})] * 10E6$$

§

Influences Under Environmental Stress 4

Crystal Characteristics: Typical 32.768 kHz crystals have an operating temperature ceiling of 60 °C, thus limit the test temperature accordingly. In addition, the temperature coefficient of these crystals can cause time-loss of approximately 3 sec/day at 60 °C.

Fork Capacitor Tuning: The timekeeping of the RTC is dependent on the RTCX1 input voltage swing. Oscillation that is marginal may result in failure to meet Vih of this input and thus “ticks” of the clock may be missed resulting in time-loss. Optimum Vpp of this RTCX1 signal is achieved by accurately matching the crystal’s C-load specification (typically 12 pF).

Board Leakage: Since this circuit operates at such low current, it is very sensitive to sources of leakage on the motherboard. Manufacturing residue can cause leakage as well as condensation on the board encountered during temperature and/or humidity testing.

Timekeeping Baseline Device: Time of motherboards is typically compared to a baseline device, like a watch or other baseline clock device believed to be accurate. The case is that most timekeeping devices like this are not sufficiently accurate. This can cause an additional source of error.

§



Optimizations for Stress Testing

5

To obtain the best RTC accuracy in environmental stress conditions, the above listed factors can be optimized. While there is little that can be done to change crystal characteristics, there are opportunities to maximize the oscillator voltage swing and to minimize board leakage; described below:

Fork Capacitor Tuning: The fork capacitors (C1/C2) must be chosen to provide the greatest V_{pp} (of RTCX1) yet still providing the best accuracy. This is typically accomplished by laboratory analysis and is specific to each motherboard (see [Section 3.1](#) for details). Analysis of several motherboards has shown that 18 pF is optimum for many designs. This analysis is accomplished by monitoring SUSCLK accuracy with extremely sensitive measurement equipment that can measure frequency to a PPM range of less than 2 ppm. The SUSCLK output is monitored (and IccRTC may be monitored) for various configurations of fork caps. All this can be accomplished at room/ambient conditions. The goal is to obtain a capacitor choice that provides greatest V_{pp} **and** the best accuracy.

Board Leakage: Care must be made to ensure that there is no manufacturing residue left on the motherboard when performing environmental stress testing. Consider a solder paste containing less flux which is an organic acid that becomes conductive in moisture. Ensure cleaning after the solder process, especially for water soluble flux. Pay careful attention to underneath discrete components of the RTC circuit and the ICH_n package.

Another source of leakage is condensation which may occur on the motherboard during an environmental stress test. This absolutely must be prevented. Choice of a non-condensing chamber profile can ensure that dew-points are not encountered. An acceptable profile is listed below, showing both temperature and relative humidity (%RH) requirements. There must be sufficient air flow in the chamber to prevent temperature spots, which could also cause condensation. The key to preventing condensation is not allowing temperature to ramp when the board is exposed to humidity. As the air temperature rises, while there is moisture in the air, the board will always be cooler than the air temperature thereby causing condensation.

Non-Condensing Temperature/Humidity Profile:

1. Hold at ambient (25 °C/25%RH) for 30 minutes.
2. Ramp temperature at a constant rate to a maximum of 60 °C over at least 30 minutes while maintaining 25%RH.
3. Ramp up %RH at a constant rate to a maximum of 85% over at least 2 hours while maintaining temperature set in step 2.
4. Hold at sustained temp/RH for user defined time.
5. Ramp down %RH at a constant rate to 25% over at least 2 hours while maintaining temperature set in step 2.
6. Ramp down temperature at a constant rate to 25 °C over at least 30 minutes while maintaining 25% RH.
7. Jump back to Step 1 **n** times.

RTC Accuracy Determination Device: Use appropriate device to check the accuracy of the RTC clock (see [Section 3-4](#) for details). §



Conclusion

6

The ICHn's RTC external oscillator is an extremely sensitive circuit because it operates at a very small current. Care must be taken when working with this circuit.

To ensure the accuracy of ICHn RTC circuit for each specific board design and RTC circuit layout, the external load capacitance should be optimized by choosing correct values of the tuning fork capacitors C1/C2.

The occurrence of time-loss under environmental stress conditions is dependent on motherboard factors (cleanliness, discrete component characteristics, layout, fork capacitor values), and condensation. If time-loss is observed on your system, check all of the sources of inaccuracy listed in this document to improve immunity of the internal ICHn oscillator to time loss.