

Océ TDS100

User manual





Océ-Technologies B.V.

Trademarks

Products in this manual are referred to by their trade names. In most, if not all cases, these designations are claimed as trademarks or registered trademarks of their respective companies.

Copyright

© 2005, Océ-Technologies B.V. Venlo, The Netherlands

All rights reserved. No part of this work may be reproduced, copied, adapted, or transmitted in any form or by any means without written permission from Océ.

Océ-Technologies B.V. makes no representation or warranties with respect to the contents hereof and specifically disclaims any implied warranties of merchantability or fitness for any particular purpose.

Further, Océ-Technologies B.V. reserves the right to revise this publication and to make changes from time to time in the content hereof without obligation to notify any person of such revision or changes.

Notes for the reader

Introduction

This manual helps you to use the Océ TDS100. The manual contains a description of the Océ TDS100 and guidelines to use and operate the Océ TDS100. There are also tips to increase your knowledge of the Océ TDS100 and to help you manage the workflow even better.

Definition

Attention Getters

Parts of this manual require your special attention. These parts provide important, additional information or are about the prevention of damage to your properties.

Note, Attention and Caution

The words **Note**, **Attention** and **Caution** indicate these important parts.

- The word **Note** comes before additional information about the correct operation of the Océ TDS100 or before a hint.
- A part marked with **Attention** contains information to prevent damage to items, for example the Océ TDS100 or a file.
- A part marked with **Caution** contains information to prevent personal injury.

Safety information

The safety information for this product is included in a separate manual with the title **Safety manual**. This manual is part of the documentation set that you received with your product.

Contents

Notes for the reader 3

Chapter 1

Introduction to the Océ TDS100

The documentation set 8

The configurations 9

The components 10

The operator panel of the automatic 1 roll and 2 roll feed configuration 12

The operator panel of the sheet feed, multi copy configuration 16

The operator panel of the sheet feed, single copy configuration 19

Chapter 2

Use the Océ TDS100

Turn on and off the Océ TDS100 22

Turn on and off the optional dew preventer 24

Copy on a media roll (automatic roll feed) 25

Copy on cut sheet media (manual sheet feed) 27

Adjust leading and trailing strips 29

Improve the copy quality of dark and light originals 32

Check the copy quality with a test strip 33

Straighten the edge of a media roll 34

Chapter 3

Maintain the Océ TDS100

Understand message codes 36

Add toner 38

Clear an original jam 41

Clear a media jam 43

Replace a media roll 46

Clean the transparent plate 51

Appendix A

Overview and tables 53

Default values 54

Product specifications 55

Supported original types and sizes 56

Supported media types and sizes 57

Appendix B**Miscellaneous 59**

Reader's comment sheet 60

Addresses of local Océ organisations 62

Chapter 1

Introduction to the Océ TDS100



The documentation set

Introduction

This manual is a part of a documentation set. The following table displays the complete list.

Overview of the complete documentation set

Document	Publication medium	Contents
Safety manual	Paper book	<ul style="list-style-type: none">■ Instructions for safe use.■ Safety data sheets.
Quick reference guide	Paper book	<ul style="list-style-type: none">■ A short description on how to operate the Océ TDS100.
User manual	CD-ROM	<ul style="list-style-type: none">■ A complete description on how to operate and maintain the Océ TDS100.

Note: Visit Océ on the internet at www.oce.com for more information.

The configurations

Introduction

The Océ TDS100 is a wide format copier to copy large drawings. The Océ TDS100 is available in four different configurations. The following table displays these configurations with their functions and options.

Functions and options per configuration

Configuration	Functions	Options
Sheet feed, single copy	<ul style="list-style-type: none">■ Manual sheet feed■ Single copy■ Original length measuring■ Reproduction scale 1:1.	<ul style="list-style-type: none">■ Stand■ A1 shelves and stand.
Sheet feed, multi copy	<ul style="list-style-type: none">■ Manual sheet feed■ Multi copy■ Trailing strip■ Original length measuring■ Reproduction scale 1:1.	<ul style="list-style-type: none">■ Stand■ A1 shelves and stand■ 1-roll upgrade kit■ 2-roll upgrade kit■ Dew preventer.
Automatic 1 roll feed	<ul style="list-style-type: none">■ Automatic 1-roll media feed■ Multi copy■ Manual sheet feed■ Trailing strip■ Leading strip■ Test strip■ Original length measuring■ Reproduction scale 1:1.	<ul style="list-style-type: none">■ 2-roll upgrade kit■ Dew preventer. <p>This configuration comes default with a stand.</p>
Automatic 2 roll feed	<ul style="list-style-type: none">■ Automatic 2-roll media feed■ Multi copy■ Manual sheet feed■ Trailing strip■ Leading strip■ Test strip■ Original length measuring■ Reproduction scale 1:1.	<ul style="list-style-type: none">■ Dew preventer. <p>This configuration comes default with a stand.</p>

[1] The Océ TDS100 configurations

The components

Introduction

The following illustration displays the most complete configuration of the Océ TDS100, the automatic 2 roll feed configuration. Some options may not be available on your TDS100 due to the differences between the configurations.

Illustration

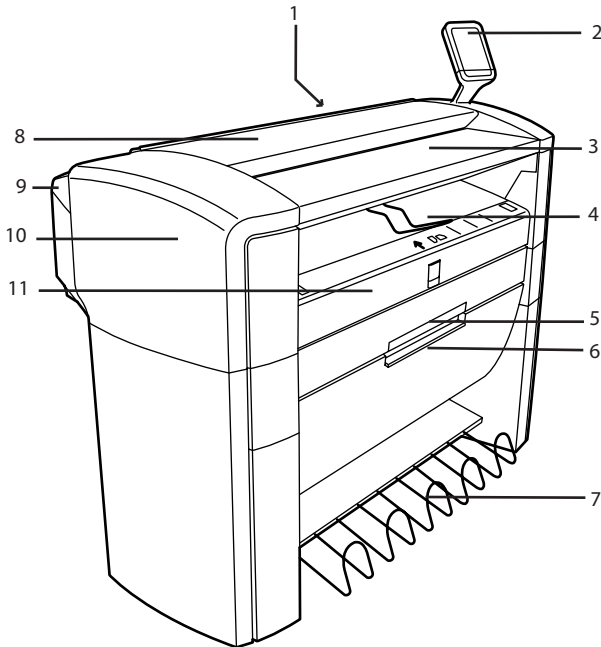

[1] The automatic 2 roll feed configuration of the Océ TDS100

The components and functions of the Océ TDS100

Nr.	Component	Function
1	On / off switch	Turn on and off the Océ TDS100. Note: The on / off switch is not visible in the illustration.
2	Operator panel	Set up, start and control the copy jobs.

Nr.	Component	Function
3	Original feed table	Feed the original.
4	Manual feed table	Feed the media manually.
5	Roll 1 (drawer)	Feed the media automatically from roll 1.
6	Roll 2 (door)	Feed the media automatically from roll 2.
7	Integrated receiving tray	Receive the copies.
8	Top cover	Give access to the transparent plate.
9	Fuser cover	Give access to the fuser. Note: <i>The fuser is not visible in the illustration.</i>
10	Left cover	Give access to the fill opening of the toner reservoir, the waste toner bag and to the handle of the fuser cover.
11	Middle cover	Give access to the underside of the manual feed table.

Note: *Some items may not be available on your Océ TDS100 due to the differences between the configurations.*

The operator panel of the automatic 1 roll and 2 roll feed configuration

Introduction

You can identify your configuration by its operator panel. The following illustration displays the operator panel of the 1 roll and 2 roll configuration.

Illustration

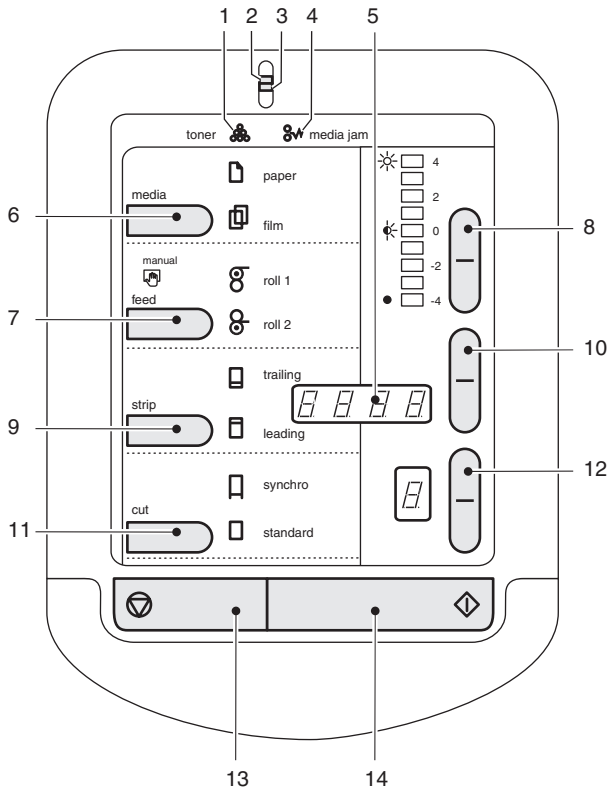

[2] The operator panel of the automatic 1 roll feed and 2 roll feed configuration

The indicators

Nr.	Indicator	Function
1	'Toner'	Indicate that the Océ TDS100 has run out of toner.
2	Green light	Indicate that the copier is ready. A blinking green light indicates that the copier runs a copy job.
3	Red light	Indicate that an error has occurred.
4	'Media jam'	<ul style="list-style-type: none"> ■ Indicate that the original or copy media has jammed. ■ Indicate that the media roll is empty for a 1 roll and 2 roll configuration. ■ Indicate that you can remove the cut off strip
5	Display	<ul style="list-style-type: none"> ■ Display the media size when you change a roll. ■ Display the strip length when you add or remove a strip. ■ Display a message code. ■ Display the length of the original when you copy manually on cut sheet media

The keys and their functions

Nr.	Key	Function
6	'Media'	Select the media type of the copy. Select one of the following. <ul style="list-style-type: none"> ■ 'Paper' ■ 'Film'
7	'Feed'	Select the media feed method. Select one of the following. <ul style="list-style-type: none"> ■ 'Roll 1' ■ 'Roll 2' (2 Roll configuration only) <ul style="list-style-type: none"> ■ 'Manual'

Nr.	Key	Function
8	Exposure	<p>Adjust the exposure.</p> <p>Use the exposure setting to correct the background of the copy. You can adjust the exposure from -4 up to +4. A negative value darkens the copy, a positive value lightens the copy.</p>
9	'Strip'	<p>Select the edge for the strip.</p> <p>Select one of the following.</p> <ul style="list-style-type: none"> ■ 'Trailing' <p>Use the adjustment key to set the trailing strip length from -100 up to +40 mm / -2.75" up to +1.75". A positive value adds a strip, a negative value removes a strip.</p> <ul style="list-style-type: none"> ■ 'Leading' <p>Use the adjustment key to set the leading strip length from -100 up to +100 mm / -2.75 - +2.75". A positive value adds a strip, a negative value removes a strip.</p> <p>(see '<i>Adjust leading and trailing strips</i>' on page 29).</p>
10	Adjustment key	<ul style="list-style-type: none"> ■ Adjust the strip length. ■ Adjust the media size for a new roll. ■ Adjust the media size for the standard cut size.
11	'Cut'	<p>Select the cut method.</p> <ul style="list-style-type: none"> ■ 'Synchro' enables you to cut the copy to the same size as the original. ■ 'Standard' enables you to cut the copy to the same size as a standard size. Use the adjustment key to set the standard size.
12	Copies	<p>Adjust the number of copies.</p> <p>You can select a number of copies from 1 up to 9.</p>

Nr.	Key	Function
13	Stop	<ul style="list-style-type: none"> <li data-bbox="580 140 1024 228">■ When you press the stop key while the copier runs a copy job, the copy job will stop. <li data-bbox="580 236 1024 323">■ When you press the stop key once while you set up a copy job, the number of copies returns to 1. <li data-bbox="580 331 1024 419">■ When you press the stop key twice while you set up a copy job, the default values return.
14	Start	Start the copy job.

The operator panel of the sheet feed, multi copy configuration

Introduction

You can identify your configuration by its operator panel. The following illustration displays the operator panel of the multi copy configuration.

Illustration

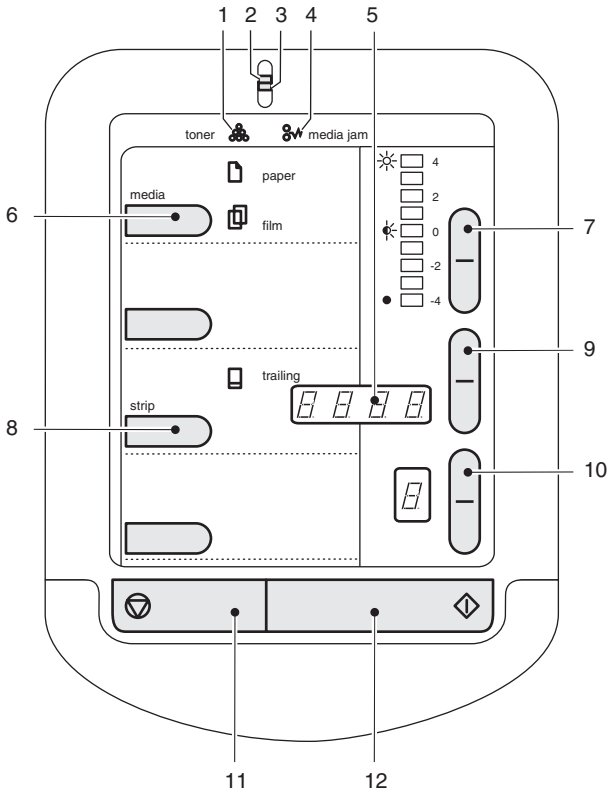

[3] The operator panel of the sheet feed, multi copy configuration

The indicators

Nr.	Indicator	Function
1	'Toner'	Indicate that the Océ TDS100 has run out of toner.
2	Green light	Indicate that the copier is ready. A blinking green light indicates that the copier runs a copy job.
3	Red light	Indicate that an error has occurred.
4	'Media jam'	■ Indicate that the original or copy media has jammed.
5	Display	■ Display the strip length when you add a trailing strip. ■ Display a message code. ■ Display the length of the original when you copy manually on cut sheet media manually

The keys

Nr.	Key	Function
6	'Media'	Select the media type of the copy. Select one of the following. ■ 'Paper' ■ 'Film'
7	Exposure	Adjust the exposure. Use the exposure setting to correct the background of the copy. You can adjust the exposure from -4 up to +4. A negative value darkens the copy, a positive value lightens the copy.

Nr.	Key	Function
8	'Strip'	<p>Select a trailing strip. Select one of the following.</p> <ul style="list-style-type: none"> ■ 'Trailing' Use the adjustment key to set the trailing strip length from -100 up to +40 mm / -2.75" up to +1.75". A positive value adds a strip, a negative value removes a strip. ■ 'Leading' Use the adjustment key to set the leading strip length from -100 up to +100 mm / -2.75 - +2.75". A positive value adds a strip, a negative value removes a strip. (see '<i>Adjust leading and trailing strips</i>' on page 29).
9	Adjustment	Adjust the strip length.
10	Copies	<p>Adjust the number of copies. You can select a number of copies from 1 up to 9.</p>
11	Stop	<ul style="list-style-type: none"> ■ When you press the stop key while the copier runs a copy job, the copy job will stop. ■ When you press the stop key once while you set up a copy job, the number of copies returns to 1. ■ When you press the stop key twice while you set up a copy job, the default values return.
12	Start	Start the copy job.

The operator panel of the sheet feed, single copy configuration

Introduction

You can identify your configuration by its operator panel. The following illustration displays the operator panel of the single copy configuration.

Illustration

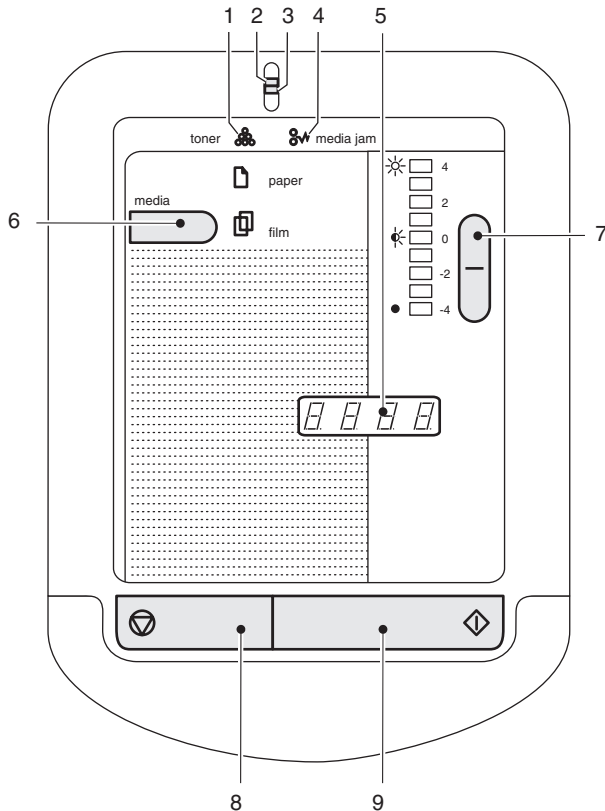

[4] The operator panel of the sheet feed, single copy configuration

The indicators

Nr.	Indicator	Function
1	'Toner'	Indicate that the Océ TDS100 has run out of toner.
2	Green light	Indicate that the copier is ready. A blinking green light indicates that the copier runs a copy job.
3	Red light	Indicate that an error has occurred.
4	'Media jam'	■ Indicate that the original or copy media has jammed.
5	Display	■ Display a message code. ■ Display the length of the original when you copy manually on cut sheet media manually

The keys

Nr.	Key	Function
6	'Media'	Select the media type of the copy. Select one of the following. ■ 'Paper' ■ 'Film'
7	Exposure	Adjust the exposure. Use the exposure setting to correct the background of the copy. You can adjust the exposure from -4 up to +4. A negative value darkens the copy, a positive value lightens the copy.
8	Stop	■ When you press the stop key while the copier runs a copy job, the copy job will stop. ■ When you press the stop key twice while you set up a copy job, the default values return.
9	Start	Start the copy job.

Chapter 2

Use the Océ TDS100



Turn on and off the Océ TDS100

Introduction

When you turn on the Océ TDS100, you can use the Océ TDS100 immediately. After you finished your copy job, you can leave the Océ TDS100 on, because the Océ TDS100 turns into the sleep mode within two minutes. The power use is very low in the sleep mode. You can recognise the sleep mode when only the green light on the operator panel illuminates and the other indicators are off.

The Océ TDS100 activates from the sleep mode when you do one of the following.

- Feed an original
- Feed the media manually
- Push a key on the operator panel
- Open a roll unit.

Illustration

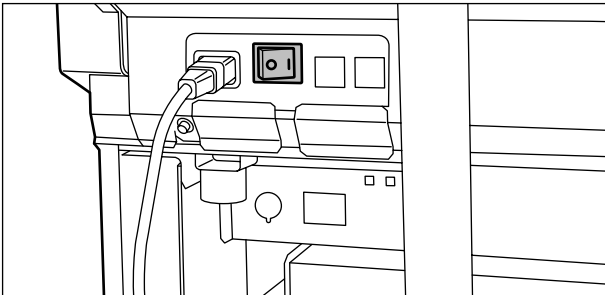

[5] The On / off switch at the back of the Océ TDS100

How to turn on the Océ TDS100

1. Set the On / off switch at the back of the Océ TDS100 to position 1.

Result

The green light at the operator panel illuminates and indicates that the Océ TDS100 is in sleep mode.

How to turn off the Océ TDS100

1. Set the On / off switch at the back of the Océ TDS100 to position 0.

Result

The green light of the On / off switch is off and the green light at the operator panel is off.

Turn on and off the optional dew preventer

Introduction

You are advised to use the optional dew preventer in an extreme humid environment to improve the copy quality in this condition.

Illustration

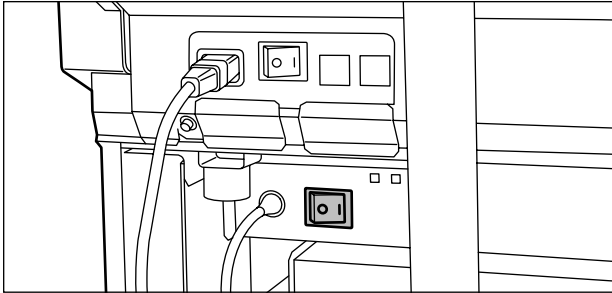

[6] The On / off switch of the dew preventer

How to turn on the dew preventer

1. Set the On / off switch at the back of the dew preventer to position 1.

Result

The green light of the On / off switch is on.

How to turn off the dew preventer

1. Set the On / off switch at the back of the dew preventer to position 0.

Result

The green light of the On / off switch is off.

Copy on a media roll (automatic roll feed)

Introduction

You can make the copies automatically on the 1 roll and 2 roll configuration.

The main steps of every automatic copy-job are the following.

1. Feed the original
2. Set up your copy job at the operator panel
3. Press the green start button.

Before you begin

Turn on the Océ TDS100.

(see 'Turn on and off the Océ TDS100' on page 22).

Attention: Feed strongly curled originals carefully, because the Océ TDS100 pulls in the original.

How to copy automatically

1. Place the original centrally and face down on the original feed table. The Océ TDS100 moves the original to the back.

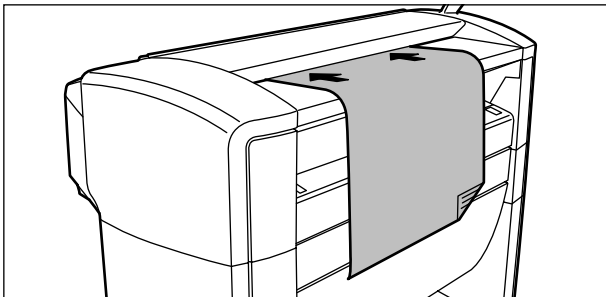

[7] Feed the original centrally and face down

2. Set up your copy job at the operator panel
 - Use the 'Media' key to select the media type to copy on.
When you press the media key, one of the following situations occur.
 - The selected media and corresponding roll illuminates. The operator panel displays the size of the media roll. If the size of the media roll is not correct, you need to replace the media roll (see '*Replace a media roll*' on page 46).
 - You can not select the media, because the requested media is not loaded. You need to replace a media roll (see '*Replace a media roll*' on page 46).
 - If both media rolls of the 2 roll configuration contain the same media, use the 'Feed' key to select the roll with the correct size.
 - Use the exposure key to correct the background of the copy.
(see '*Improve the copy quality of dark and light originals*' on page 32).
 - Use the 'Strip' key and adjustment key to add or remove a leading or trailing strip.
(see '*Adjust leading and trailing strips*' on page 29).
 - Use the 'Cut' key to select the cut method.
 - Use the copies key to set the number of copies.
3. Press the green start button to start the copy job.

Result

The Océ TDS100 runs the copy job with automatic media feed.

Copy on cut sheet media (manual sheet feed)

Introduction

You can make the copies manually on all configurations.

The main steps of every manual copy-job are the following.

1. Feed the original
2. Feed the cut sheet
3. Set up your copy job at the operator panel
4. Press the green start button.

Before you begin

Turn on the Océ TDS100.

(see 'Turn on and off the Océ TDS100' on page 22).

Attention: Feed strongly curled originals carefully, because the Océ TDS100 pulls in the original.

How to copy manually

1. Place the original centrally and face down on the original feed table
The Océ TDS100 moves the original to the back.

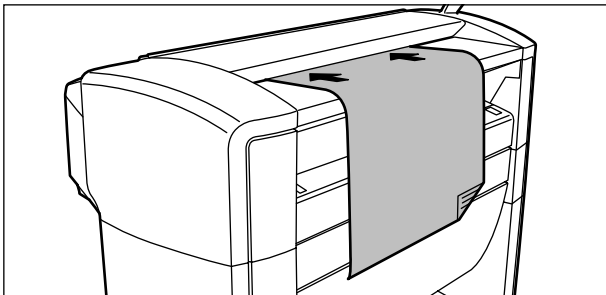

[8] Feed the original centrally and face down

2. Place the cut sheet media centrally and face up on manual feed table

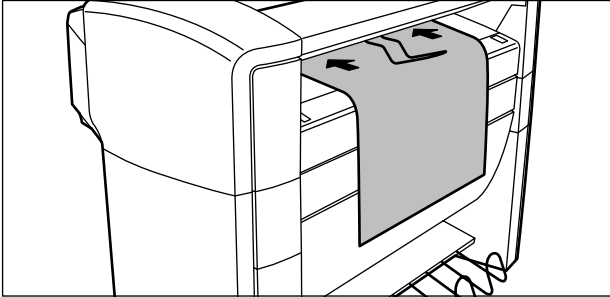

[9] Feed the cut sheet media centrally

The operator panel illuminates 'Manual' and displays the length of the original.

3. Set up your copy job at the operator panel
 - Use the 'Media' key to select the media type to copy on
 - Use the exposure key to correct the background of the copy.
(see '*Improve the copy quality of dark and light originals*' on page 32).
 - Use the 'Strip' key and adjustment key to add or remove a leading or trailing strip ¹.
(see '*Adjust leading and trailing strips*' on page 29).
 - Use the copies key to set the number of copies ¹
4. Press the green start button to start the copy job.

Note: ¹ Not available on the single copy configuration.

Result

The Océ TDS100 runs the copy job with manual media feed.

Adjust leading and trailing strips

Introduction

Both originals and copies can contain a strip to file it. The Océ TDS100 allows you to handle strips as follows.

- Remove a strip
- Add a strip.

You can adjust the following strips.

- Leading strip.
A leading strip is at the beginning of the original where you feed the original (see figure 10 on page 30).
- Trailing strip.
A trailing strip is at the end of the original, the loosen end (see figure 11 on page 30).

When to do

Use the strip function to do the following.

- When you need to copy an original with a strip to a copy without a strip, remove a strip
- When you need to copy an original without a strip to a copy with a strip, add a strip.

Attention: *When you remove a strip, make sure that you copied all the required information.*

How to add or remove a leading strip

1. Place the original centrally and face down on the original feed table.
The Océ TDS100 moves the original to the back.

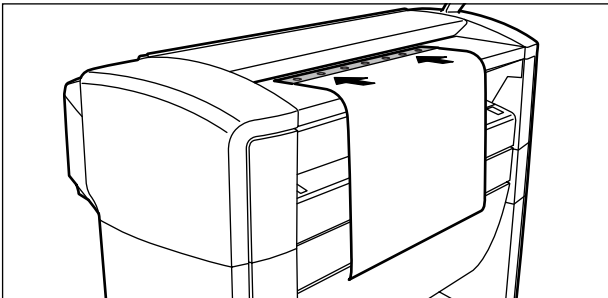

[10] Feed the original with leading strip centrally and face down

2. Use the 'Strip' key to select 'Leading'
3. Use the adjustment key to add or remove a leading strip
A positive value adds a strip, a negative value removes a strip
4. Press the green start button to start the copy job.

How to add or remove a trailing strip

1. Place the original centrally and face down on the original feed table.
The Océ TDS100 moves the original to the back.

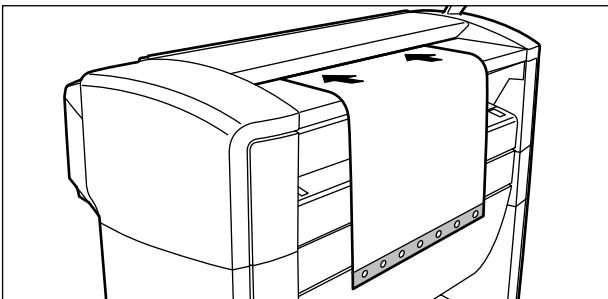

[11] Feed the original with trailing strip centrally and face down

2. Use the 'Strip' key to select 'Trailing'
3. Use the adjustment key to add or remove a trailing strip.
A positive value adds a strip, a negative value removes a strip.
4. Press the green start button to start the copy job.

Result

The Océ TDS100 adds or removes a leading or a trailing strip.

Improve the copy quality of dark and light originals

Introduction

You can use the exposure setting to improve the copy quality of a dark or light original.

How to correct a dark original

1. Use the exposure key to select a value between 0 and +4 to lighten the copy.

How to correct a light original

1. Use the exposure key to select a value between 0 and -4 to darken the copy.

Result

The copy has a clear background with a sharp image.

Check the copy quality with a test strip

Introduction

Before you start your copy job, you can check the result of your settings on the copy quality with a test strip.

Attention: *If the original contains a filing strip, make sure that the filing strip is at the trailing edge (see 'Adjust leading and trailing strips' on page 29).*

How to make a test strip

1. Place the original centrally and face down on the original feed table. The Océ TDS100 moves the original to the back.

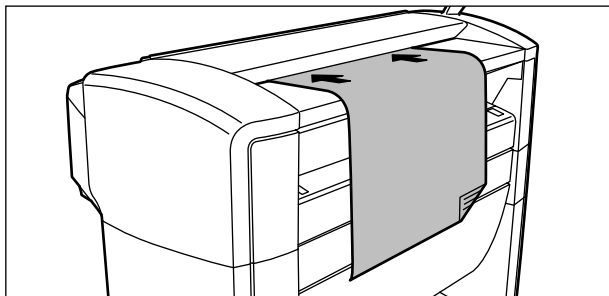

[12] Feed the original centrally and face down

2. Press the 'Cut' key to select 'Standard'
3. Press the upper side of the adjustment key
The text 'TEST' appears on the display.
4. Press the green start button to copy a strip.

Result

The Océ TDS100 copies only a strip of the original.

Straighten the edge of a media roll

Introduction

You can use the 'Cut' function to make the edge of a roll straight.

Before you begin

Remove the original from the original feed table.

How to cut the edge of a roll

1. Use the 'Feed' key to select a roll
2. Use the 'Cut' key to select 'Standard'
3. Press the upper side of the adjustment key.
The text 'TEST' appears on the display.
4. Press the green start button to cut the edge of the roll.
The message code 'E 3' appears on the display to indicate that you need to remove the cut off strip.
5. Open the drawer to remove the cut off strip
6. If the drawer does not contain the cut off strip, open the middle cover and remove the cut off strip
7. Close the middle cover if necessary
8. Close the drawer.

Result

The edge of the roll is straight.

Chapter 3

Maintain the Océ TDS100



Understand message codes

Introduction

The Océ TDS100 displays a message code when the copier is not ready to use. The following table shows a summary of the messages codes, the possible cause and the action to take.

What the message code describes

Code	Possible cause	Action
E 0	■ The original is jammed	■ Clear the original jam (see ' <i>Clear an original jam</i> ' on page 41)
	■ The media feed stopped during a copy job	■ Clear the media jam (see ' <i>Clear a media jam</i> ' on page 43)
	■ The red stop key was pushed during a copy job.	■ Clear the original jam (see ' <i>Clear an original jam</i> ' on page 41) ■ Clear the media jam (see ' <i>Clear a media jam</i> ' on page 43)
E 1	■ The manual feed table is open.	■ Open the middle cover and lift the manual feed table (see figure 19 on page 44)
E 2	■ The copy media is too short.	■ Use longer cut sheet media
E 3	■ The media is jammed	■ Check the media feed (see ' <i>Clear a media jam</i> ' on page 43)
	■ The cut off strip is not removed.	■ Remove the cut off strip (see ' <i>Straighten the edge of a media roll</i> ' on page 34)

Code	Possible cause	Action
E 4	<ul style="list-style-type: none"> ■ The drawer with roll 1 or the door in front of roll 2 was opened during a copy job 	<ul style="list-style-type: none"> ■ Close the drawer or the door ■ Clear the original jam (see '<i>Clear an original jam</i>' on page 41) ■ Clear the media jam (see '<i>Clear a media jam</i>' on page 43)
E 5	<ul style="list-style-type: none"> ■ The media roll is empty 	<ul style="list-style-type: none"> ■ Replace the media roll (see '<i>Replace a media roll</i>' on page 46)

Add toner

Introduction

The Océ TDS100 illuminates the toner low indicator when the toner level is low.

When the toner low indicator illuminates, you need to do the following.

- Add toner
- Replace the waste toner bag.

Note: *If you ignore the toner low indicator, the copy quality will decrease.*

When to do

Add toner and replace the waste toner bag when the toner low indicator illuminates. You can finish your copy job before you add the toner and replace the waste toner bag.

Before you begin

Shake the toner bottle thoroughly.

Attention: *Use TDS100 toner only.*

How to add toner and replace the waste toner bag

1. Loosen the nut at the left back side.
Open the left cover.

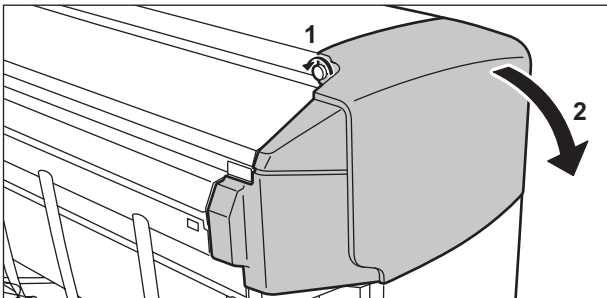

[13] Open the left cover

2. Before you open the bottle, shake the bottle thoroughly.
Put the toner bottle in the bottle holder.
Turn the bottle clockwise to fasten the bottle

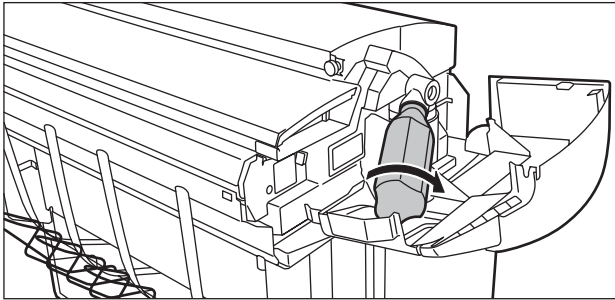

[14] Fasten the bottle

3. Turn the bottle in the vertical position

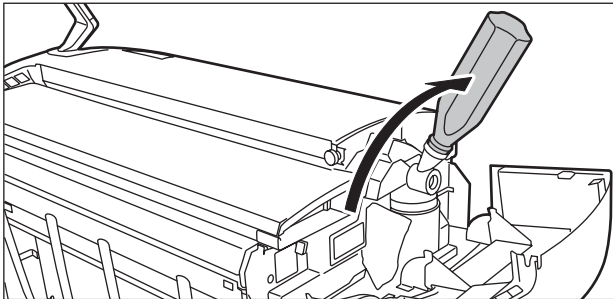

[15] Turn the bottle

The toner flows into the Océ TDS100.

4. Wait until the bottle is empty
Return the bottle into the original position
5. Turn the bottle anticlockwise to loosen the bottle from the bottle holder
6. Pull the waste toner bag from its holder.
Close the waste toner bag.

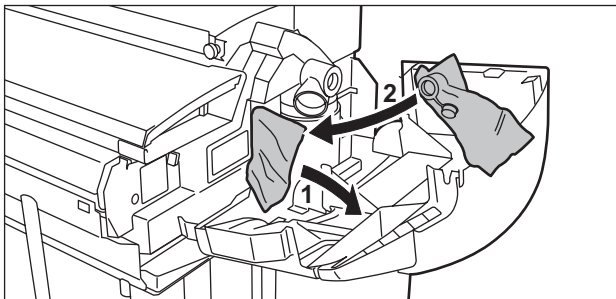

[16] Remove and close the waste toner bag

7. Slide the new waste toner bag over the holder
8. Close the left cover and tighten the nut at the left back side.

Result

The toner level of the Océ TDS100 is high, the toner low indicator is off and the wasted toner bag is removed. The Océ TDS100 is ready to copy.

Clear an original jam

Introduction

The media jam indicator blinks and the message code 'E 0' displays to indicate that an original jam occurred. The type of original determines how to clear the original jam. The types of originals are divided into the following.

- Fragile originals
- Normal originals.

When to do

You need to clear an original jam in the following situations.

- The original is jammed
- The media feed stopped during the copy job
- The red stop key was pushed during a copy job.

How to remove a fragile original

1. Pull the top cover towards you and lift the top cover to open it.

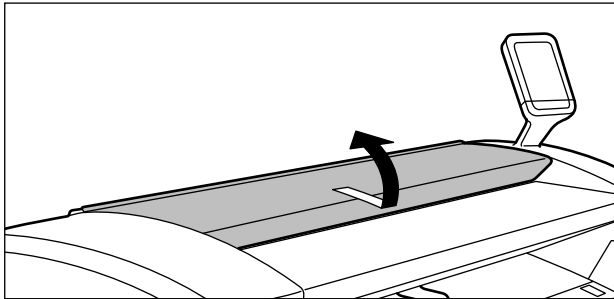

[17] Open the top cover

2. Remove the original
3. Lower and push the top cover backwards until you hear or feel a click
4. Check on a media jam also and clear the media jam if necessary.
(see 'Clear a media jam' on page 43)

How to remove a normal original

1. Pull the original carefully with two hands toward you
2. Check on a media jam also and clear the media jam if necessary.
(see 'Clear a media jam' on page 43)

Result

The original jam is cleared and the media indicator is off. The Océ TDS100 is ready to copy.

Clear a media jam

Introduction

The media jam indicator blinks and the message code 'E 3' displays to indicate that a media jam occurred. A media jam can occur in one of the following sections

- The manual media feeder
- The fuser section.

When to do

You need to clear a media jam in the following situations.

- The media roll feed is jammed
- The manual cut sheet feed is jammed
- The red button was used during a copy job.

How to remove the media from the manual feeder

1. Open the middle cover

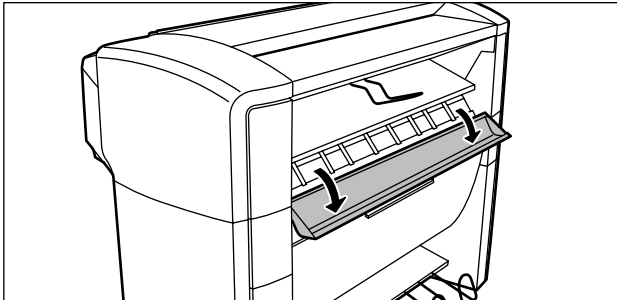

[18] Open the middle cover

2. Press the two handles at the underside of the manual feed table to lower the manual feed table

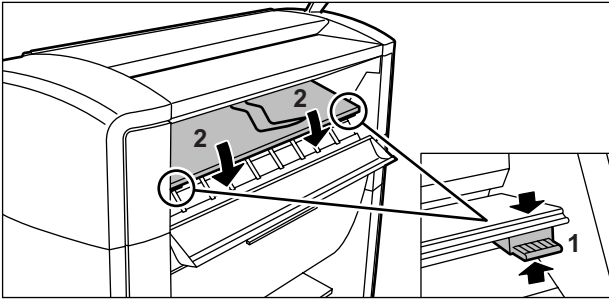

[19] Lower the manual feed table

3. Remove the jammed media carefully
4. Lift the manual feed table until you hear or feel a click
5. Close the middle cover
6. Check on an original jam also and clear the original jam if necessary.(see 'Clear an original jam' on page 41)

How to remove the media from the fuser section

Caution: *The fuser section can be hot.*

Attention: *The jammed media can contain loose toner.*

1. Turn off the Océ TDS100
2. Loosen the nut at the left back side.
Open the left cover.

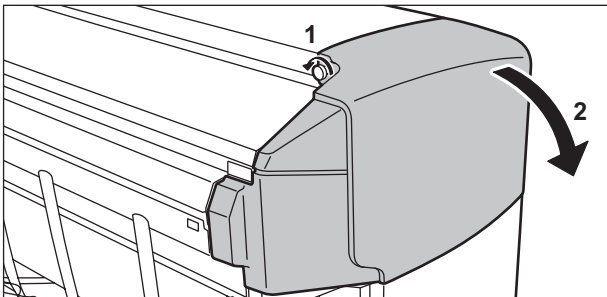

[20] Open the left cover

3. Lift the green handle and open the fuser unit

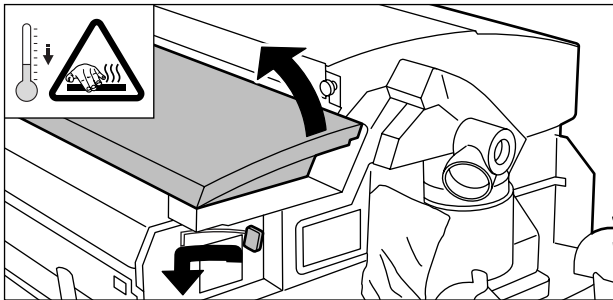

[21] Open the fuser unit

4. Remove the jammed media carefully
Note: *Make sure that you remove all jammed media.*
5. Lift the green handle and close the fuser unit

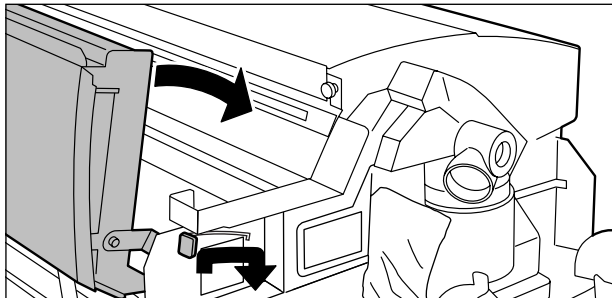

[22] Close the fuser cover

6. Close the left cover.
Tighten the nut at the left back side.
7. Check on an original jam also and clear the original jam if necessary
(see ‘*Clear an original jam*’ on page 41)
8. Turn on the Océ TDS100.

Result

The media jam is cleared and the media indicator is off. The Océ TDS100 is ready to copy.

Replace a media roll

Introduction

The media jam indicator blinks and the message code 'E 5' displays to indicate that a media roll is empty. When you replace a media roll, you need to check or set the following before you close the roll section.

- The media type
- The roll number
- The media size.

When to do

You need to replace the media roll in the following situations.

- The media jam indicator indicates that the media roll is empty
- You want to use another media type or size.

How to replace roll 1

1. Pull the handle of the drawer to open the drawer with roll 1

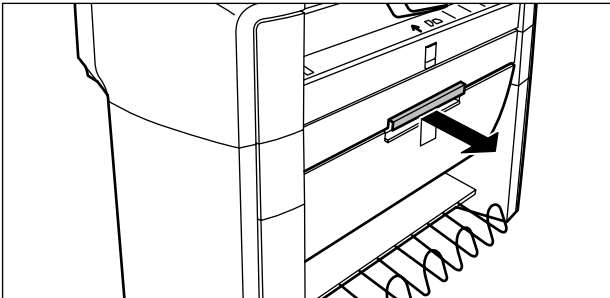

[23] Open the drawer with roll 1

2. Remove the roll holder from the drawer

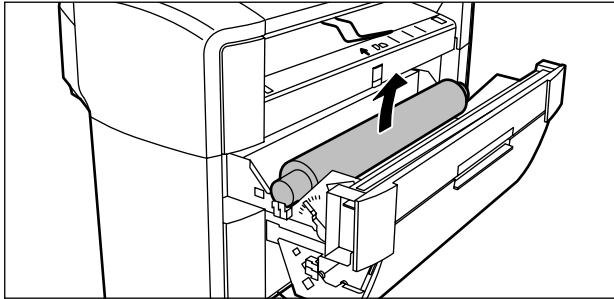

[24] Remove the roll holder

3. Press the knob of the roll holder to remove the old media roll from the roll holder

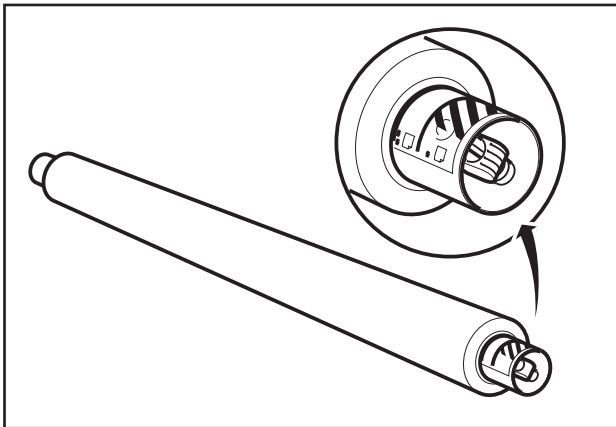

[25] Press the knob of the roll holder

4. Press the knob of the roll holder and slide the roll holder into the new roll.
Press the knob of the roll holder to align the new roll with the correct media size on the roll holder.
5. Place the roll holder with the new media roll in the drawer.
Make sure you put the loose end of the media roll in the correct position.

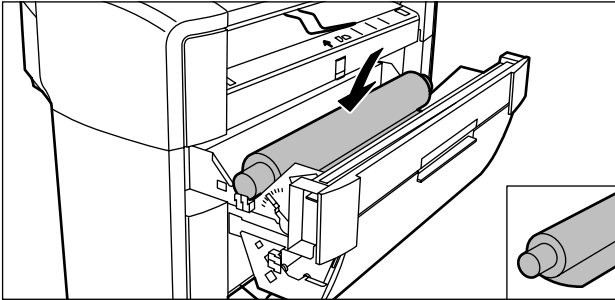

[26] Place the roll holder in the drawer

6. Feed the media as far as the wheels.
Turn the wheels to feed the media as far as the arrow on the sticker.

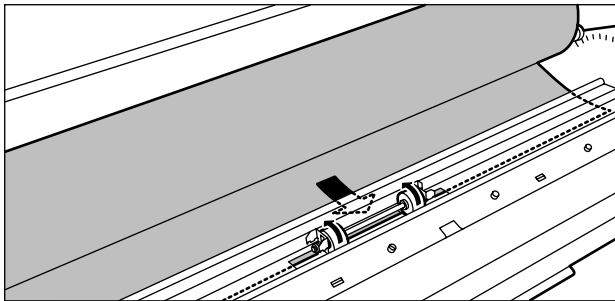

[27] Make sure you feed the media as far as the arrow on the sticker

7. Use the 'Media' key to select the media type of the new roll
Note: Use 'Paper' for all media except for polyester film, use 'Film' for polyester film.
8. Use the 'Feed' key to select 'Roll 1'
9. Use the adjustment key to select the media size of the new roll
10. Close the drawer with roll 1.

How to replace media roll 2

1. Lift and turn the door in front of roll 2

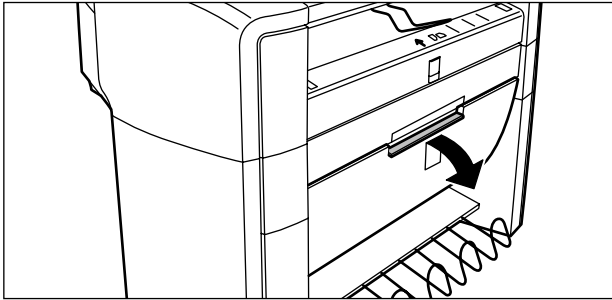

[28] Open the door in front of roll 2

2. Remove the roll holder
3. Press the knob of the roll holder to remove the old media roll from the roll holder

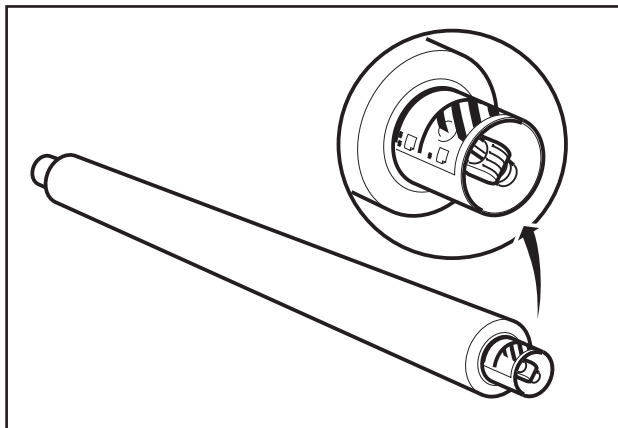

[29] Press the knob of the roll holder

4. Press the knob of the roll holder and slide the roll holder into the new roll.
Press the knob of the roll holder to align the new roll with the correct media size on the roll holder.
5. Place the roll holder with the new media roll in the drawer.
Make sure you put the loose end of the media roll in the correct position.

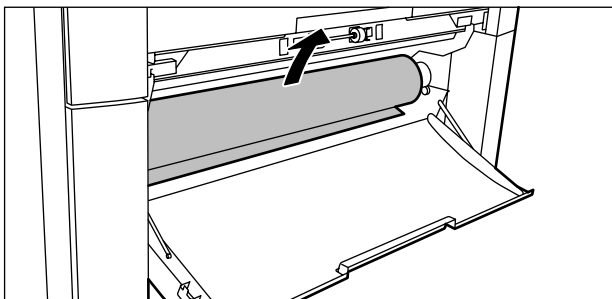

[30] Place the roll holder

6. Feed the media as far as the wheels.
Turn the wheels to feed the media as far as the arrow on the sticker.

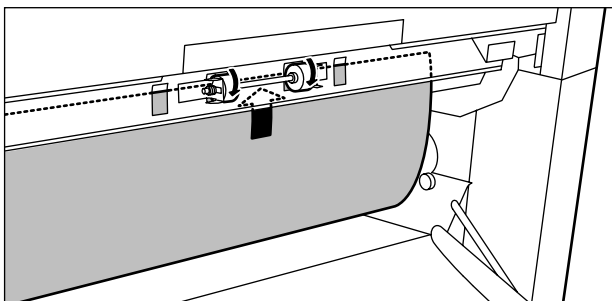

[31] Make sure you feed the media as far as the arrow on the sticker

7. Use the 'Media' key to select the media type of the new roll
Note: Use 'Paper' for all media except for polyester film, use 'Film' for polyester film.
8. Use the 'Feed' key to select 'Roll 2'
9. Use the adjustment key to select the media size of the new roll
10. Close the door in front of roll 2.

Result

The media roll is replaced.

Clean the transparent plate

Introduction

You need to keep the transparent plate clean. A dirty transparent plate causes a decreased copy quality.

When to do

Clean the transparent plate when you have spots on the copies that are not on the original.

Required tools

'Océ cleaner A', part of cleaning kit with codenumber 1068117.

2 lint-free cloths

Attention: Use 'Océ cleaner A' to reach the best results.

Attention: Make sure you do not damage the sensor at the centre of the transparent plate.

How to clean the transparent plate

1. Turn off the Océ TDS100
2. Pull the top cover towards you and lift the top cover to open it.

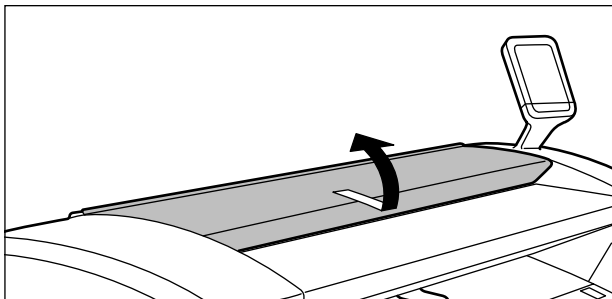

[32] Open the top cover

3. Clean the transparent plate with a lint-free cloth and a small quantity of the cleaner

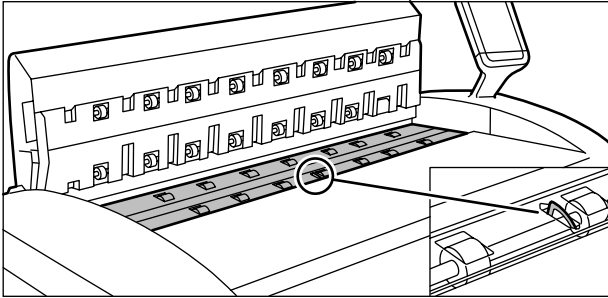

[33] Do not damage the sensor at the centre of the transparent plate

4. Dry the transparent plate with another lint-free cloth
5. Clean the white plate
6. Lower and push the top cover backwards until you hear or feel a click
7. Turn on the Océ TDS100.

Result

The transparent plate is clean and the copy shows no spots.

Appendix C

Overview and tables



Default values

Introduction

The default values of the settings are active in the following situations.

- Turn on the Océ TDS100
- Use the Océ TDS100 after sleep mode
- Press the red stop key twice.

The default values of the settings of the sheet feed, single copy configuration

Setting	Value
Media	Paper
Exposure	0

The default values of the settings of the sheet feed, multi copy configuration

Function	Value
Media	Paper
Exposure	0
Strip	Off
Copies	1

The default values of the settings of the automatic 1 roll and 2 roll feed configurations

Function	Value
Media	Roll 1
Feed	Paper
Exposure level	0
Strip	Off
Cut	Synchro
Copies	1

Product specifications

Product specifications

Feature	Specification
Copy process	Dry indirect electrostatic Organic photo conductor Closed binary toner system Instant heating system
Warm-up time	None
Copy speed	3 metres per minute
Maximum media width	914 mm (36")
Scale	1:1 +/- 0.5% valid for A0 or 48" and smaller

[2] The product specifications of the Océ TDS100

The validity of the product specifications

The recommended operating environment is 30 - 60 % relative humidity and 20 - 27 °C temperature. The operating environment is 20 - 60 % relative humidity and 17 - 30 °C temperature

Note: *The performance and copy quality is not guaranteed outside the recommended operating environment.*

Supported original types and sizes

Overview of supported original types and sizes

Parameter	Minimum value	Recommended maximum value
Width	210 mm (8.5")	1000 mm (40")
Length	279 mm (10")	3000 mm (10") (maximum value: 30 m)
Length in retention		1200 mm (48")
Thickness	0.05 mm	1.5 mm
Weight	60 g/m ²	120 g/m ² (maximum value: 210 g/m ²)

[3] The supported original types and sizes of the Océ TDS100

Overview of the conditions of the originals

Topic	Recommendation
Curl	Feed curled originals extra careful. When the diameter of a curl is less than 50 mm, use a carrier sheet.
Paste up	Make sure that paste up's are completely pasted on all edges or use a carrier sheet
Filing strip	Filing strips are allowed on all edges, the maximum diameter of the hole is 36 mm
Border	Use a carrier sheet when the border is damaged, contains reinforcement strips with holes bigger than 36 mm, or punching holes
Fold	Shadows of the folds may be visible on the copy
Fragile or thin media	Use a carrier sheet

[4] The conditions of the originals

Supported media types and sizes

Introduction

Océ systems and materials are matched for optimal quality and performance. You are therefore recommended to use only approved Océ materials in the Océ TDS100. A full list of Océ materials is suitable for use in the Océ TDS100. The list includes plain paper, transparent paper, coloured papers and different polyester films is available from your Océ representative.

Attention: *Do not store the media in an environment with a high humidity, high temperature, direct sunlight or dust. Keep the media in the original package as much as possible to ensure optimal copy quality.*

Attention: *Feed curled media with the curl face down to prevent damage to the drum section.*

Caution: *Do not use metalbased or conductive media to prevent injury to a person.*

Overview of recommended media

Media or parameter	Recommended type or size
Plain paper	75 g/m ²
Transparent paper	110/115 g/m ²
Vellum	20 lbs
Polyester film	3.5/4.5 mil
ECO papers	75/80 g/m ²
Opaque paper	75 g/m ²
Width	Minimum 297 mm / 11", maximum 914 mm / 36"
Length	Minimum 420 mm / 17", maximum any easy to manage size

[5] The recommended media types of the Océ TDS100

Overview of supported media

The copy quality on the supported media can be less than on the recommended media.

Media	Supported type	Remark
Plain paper	100/110 g/m ²	
Transparent paper	60 g/m ² 80/85 g/m ² 90/95 g/m ²	
Vellum	16 lbs	
Clear polyester film	4 mil	
Contrast film	3.5 mil	
Contrast paper	135 g/m ²	Guaranteed up to 50% RH
Opaque paper	110 g/m ²	Guaranteed up to 50% RH
Fluor paper	90 g/m ²	
Pastel paper	80 g/m ²	

[6] The supported media types of the Océ TDS100.

Appendix D

Miscellaneous



Reader's comment sheet

Questions

Have you found this manual to be accurate?

- Yes
- No

Were you able to operate the product, after reading this manual?

- Yes
- No

Does this manual provide sufficient background information?

- Yes
- No

Is the format of this manual convenient in size, readability and arrangement (page layout, chapter order, etc.)?

- Yes
- No

Could you find the information you were looking for?

- Always
- Most of the times
- Sometimes
- Not at all

What did you use to find the required information?

- Table of contents
- Index

Are you satisfied with this manual?

- Yes
- No

Thank you for evaluating this manual.

If you have other comments or concerns, please explain or suggest improvements overleaf or on a separate sheet.

Comments:

Date:

This reader's comment sheet is completed by:
(If you prefer to remain unknown, please do fill in your occupation)

Name:

Occupation:

Company:

Phone:

Address:

City:

Country:

Please return this sheet to:

Océ-Technologies B.V.
For the attention of ITC User Documentation.
P.O. Box 101,
5900 MA Venlo
The Netherlands

Send your comments by E-mail to: itc-userdoc@oce.nl

For the addresses of local Océ organisations see: <http://www.oce.com>

Addresses of local Océ organisations

<p>Océ-Australia Ltd. P.O. Box 363 Ferntree Gully MDC Vic 3165 Australia http://www.oce.com.au/</p>	<p>Océ-Osterreich GmbH Postfach 95 1233 Vienna Austria http://www.oce.at/</p>
<p>Océ-Belgium N.V./S.A. J. Bordetlaan 32 1140 Brussel Belgium http://www.oce.be/</p>	<p>Océ-Brasil Comércio e Indústria Ltda. Av. das Nações Unidas, 11.857 Brooklin Novo São Paulo-SP 04578-000 Brasil http://www.oce-brasil.com.br/</p>
<p>Océ-Canada Inc. 4711 Yonge Street, Suite 1100 Toronto, Ontario M2N 6K8 Canada http://www.oce.ca/</p>	<p>Océ Office Equipment (Beijing) Co., Ltd. Xu Mu Cheng Chaoyang District Beijing 100028 China http://www.oce.com.cn</p>
<p>Océ-Czech Republic ltd. Hanusova 18 140 21 Praha 4 Czech Republic http://www.oce.cz/</p>	<p>Océ-Danmark a/s Vallensbækvej 45 2605 Brøndby Denmark http://www.oce.dk/</p>
<p>Océ Finland OY Tallberginkatu 2 A, PL 163 00180 Helsinki Finland http://www.oce.fi</p>	<p>Océ-France S.A. 32, Avenue du Pavé Neuf 93161 Noisy-le-grand, Cedex France http://www.oce.fr/</p>

<p>Océ-Deutschland GmbH Solinger Straße 5-7 45481 Mülheim/Ruhr Germany http://www.oce.de/</p>	<p>Océ-Hong Kong and China head office 12/F 1202 The Lee Gardens 33 Hysan Avenue Causeway Bay Hong Kong http://www.oce.com.hk/</p>
<p>Océ-Hungaria Kft. 1241 Budapest Pf.: 237 Hungary http://www.oce.hu/</p>	<p>Océ-Ireland Ltd. 3006 Lake Drive Citywest Business Campus Saggart Co. Dublin Ireland</p>
<p>Océ-Italia S.p.A. Strada Padana Superiore 2/B 20063 Cernusco sul Naviglio (MI) Italia http://www.oce.it/</p>	<p>Océ Japan Corporation 3-25-1, Nishi Shinbashi Minato-Ku Tokyo 105-0003 Japan http://www.cejapan.co.jp/</p>
<p>Océ-Belgium S.A. Rue Astrid 2/A 1143 Luxembourg-Belair http://www.oce.lu/indexfr.htm</p>	<p>Océ Malaysia Sdn. Bhd. #3.01, Level 3, Wisma Academy Lot 4A, Jalan 19/1 46300 Petalig Jaya Selangor Darul Ehsan Malaysia www.ocemal.com.my</p>
<p>Océ-Mexico S.A. de C.V. Prolongación Reforma 1236, 4to Piso Col. Santa Fé, Del. Cuajimalpa C.P. 05348 México, D.F. México www.oceusa.com</p>	<p>Océ-Norge A.S. Postboks 4434 Nydalen Gjerdrums vei 8 0403 Oslo Norway http://www.oce.no</p>

<p>Océ-Poland Ltd. Sp.z o.o. ul. Bitwy Warszawskiej 1920 r. nr. 7 02-366 Warszawa Poland http://www.oce.com.pl</p>	<p>Océ-Lima Mayer, S.A. Av. José Gomes Ferreira, 11 Piso 2 - Miraflores 1497-139 Algés Portugal</p>
<p>Océ Singapore Pte Ltd. 190 MacPherson Road #03-00 Wisma Gulab Singapore 348548</p>	<p>Océ Printing Systems (PTY) Ltd. P.O.Box 629 Rivonia 2128 South Africa</p>
<p>Océ España SA Business Park Mas Blau Osona, 2 08820 El Prat de Llobregat Barcelona Spain http://www.oce.es</p>	<p>Océ-Svenska AB P.O. Box 754 S-191 27 Sollentuna Sweden http://www.oce.se</p>
<p>Océ-Schweiz AG Sägereistrasse 10 CH8152 Glattbrugg Schweiz http://www.oce.ch</p>	<p>Océ (Thailand) Ltd. B.B. Building 16/Floor 54 Asoke Road Sukhumvit 21 Bangkok 10110 Thailand</p>
<p>Océ-Nederland B.V. P.O.Box 800 5201 AV 's-Hertogenbosch The Netherlands http://www.ocenl.nl/</p>	<p>Océ (UK) Limited Océ House Chatham Way Brentwood, Essex CM14 4DZ United Kingdom http://www.oce.co.uk</p>
<p>Océ North America Inc. 5450 North Cumberland Avenue Chicago, IL 60656 USA www.oceusa.com</p>	

Note: *The web site <http://www.oce.com> gives the current addresses of the local Océ organisations and distributors.*

Note: *The addresses of local Océ organisations for information about the Wide Format Printing Systems and the Production Printing Systems can be different from the addresses above. Refer to the web site <http://www.oce.com> for the addresses you need.*

Index

A

- add toner 38
- adjustment key (1 & 2 roll configuration) 12
- adjustment key (multi copy configuration) 16
- automatic feed copy 25

B

- background compensation 32

C

- clean the transparent plate 51
- clear a media jam 43
- clear an original jam 41
- components overview 10
 - fuser cover 10
 - integrated receiving tray 10
 - left cover 10
 - manual feed table 10
 - middle cover 10
 - on / off switch 10
 - operator panel 10
 - original feed table 10
 - roll 1 (drawer) 10
 - roll 2 (door) 10
 - top cover 10
- configurations 9
- configurations overview 9
- copy on a media roll 25
- copy on cut sheet 27
- copy quality
 - make a test strip 33
 - set the exposure 32
- copy with automatic feed 25
- copy with manual feed 27
- cut 34

- cut (method, 1 & 2 roll configuration) 12
- cut length (1 & 2 roll configuration) 12

D

- dark original 32
- default settings 54
- default values 54
- display (1 & 2 roll configuration) 12
- display (multi copy configuration) 16
- display (single copy configuration) 19
- documentation set 8

E

- e codes 36
- edge 34
- exposure 32
- exposure (1 & 2 roll configuration) 12
- exposure (multi copy configuration) 16
- exposure (single copy configuration) 19

F

- feed (method, 1 & 2 roll configuration) 12
- functions overview 9
- fuser cover 10

G

- green light (1 & 2 roll configuration) 12
- green light (multi copy configuration) 16
- green light (single copy configuration) 19

I

- integrated receiving tray 10

J

- jam
 - media jam 43
 - original jam 41

L

- leading strip 29
- left cover 10
- light original 32

M

- manual feed copy 27
- manual feed table 10
- media
 - recommended media types 57
 - set media size 46
 - set media type 46
 - supported media sizes 57
 - supported media types 57
- media (type, 1 & 2 roll configuration) 12
- media (type, multi copy configuration) 16
- media (type, single copy configuration) 19
- media jam 43
- media jam indicator (1 & 2 roll configuration) 12
- media jam indicator (multi copy configuration) 16
- media jam indicator (single copy configuration) 19
- media roll 46
- media sizes 57
- media types 57
- message codes
 - e 0 36
 - e 1 36
 - e 2 36
 - e 3 36
 - e 4 36
 - e 5 36
- message codes overview 36
- middle cover 10

N

- number of copies (1 & 2 roll configuration) 12
- number of copies (multi copy configuration) 16

O

- on / off switch 10, 22
- operator panel 10
- operator panel 1 & 2 roll configuration 12
 - adjustment key 12
 - cut (method) 12
 - cut length 12
 - display 12
 - exposure 12
 - feed (method) 12
 - green light 12
 - media (type) 12
 - media jam indicator 12
 - number of copies 12
 - red light 12
 - start 12
 - stop 12
 - strip 12
 - strip length 12
 - toner indicator 12
- operator panel multi copy configuration 16
 - adjustment key 16
 - display 16
 - exposure 16
 - green light 16
 - media (type) 16
 - media jam indicator 16
 - number of copies 16
 - red light 16
 - start 16
 - stop 16
 - strip 16
 - strip length 16
 - toner indicator 16
- operator panel single copy configuration 19
 - display 19
 - exposure 19
 - green light 19
 - media (type) 19
 - media jam indicator 19

red light 19
start 19
stop 19
toner indicator 19
options overview 9
original feed table 10
original jam 41
original sizes 56
original types 56

P

product specifications 55

R

red light (1 & 2 roll configuration) 12
red light (multi copy configuration) 16
red light (single copy configuration) 19
replace a media roll 46
roll 1 (drawer) 10
roll 2 (door) 10

S

specifications 55
start (1 & 2 roll configuration) 12
start (multi copy configuration) 16
start (single copy configuration) 19
stop (1 & 2 roll configuration) 12
stop (multi copy configuration) 16
stop (single copy configuration) 19
strip
 adjust a leading strip 29
 adjust a trailing strip 29
strip (1 & 2 roll configuration) 12
strip (multi copy configuration) 16
strip length (1 & 2 roll configuration) 12
strip length (multi copy configuration) 16
supported original sizes 56
supported original types 56

T

test strip 33
toner 38
toner indicator (1 & 2 roll configuration) 12
toner indicator (multi copy configuration) 16
toner indicator (single copy configuration) 19
top cover 10
trailing strip 29
transparent plate 51
turn on and off 22

W

waste toner bag 38

