



Full HD Multi-Stream Compact Dome IP Camera

LP200



User's Manual

Ver 4.17

Table of Contents

1. Overview	3
1.1 Features	3
1.2 Package Contents	4
1.3 Dimensions	5
1.4 Connectors	6
2. Camera Cabling	7
2.1.1 Indoor Camera	7
3. System Requirements	9
4. Access Camera	10
5. Setup Video Resolution	14
6. Configuration Files Export/ Import	21
7. Menu Tree	22
7.1 Home Page	23
7.1.1 Function Items on Home Page	23
7.1.2 Function Differences between Models	26
7.2 System	27
7.2.1 System	27
7.2.2 Security	29
7.2.3 Network	34
7.2.4 DDNS	39
7.2.5 Mail	39
7.2.6 FTP	40
7.2.7 HTTP	40
7.2.8 Application (Compact Fixed Dome Excluded)	41
7.2.9 Motion Detection	45
7.2.10 Tampering	52
7.2.11 Storage Management (Local Recording)	55
7.2.12 Recording (Local Recording)	57
7.2.13 File Location (Snapshots and Web Recording)	58
7.2.14 Iris Adjustment (Fixed Focal Lens Excluded)	58
7.2.15 View Log File	58
7.2.16 View User Information	59
7.2.17 View Parameters	59
7.2.18 Factory Default	60
7.2.19 Software Version	60
7.2.20 Software Upgrade	61
7.2.21 Maintenance	62

7.3	Streaming	63
7.3.1	Video Format (Video Resolution and Rotate Type)	63
7.3.2	Video Compression	64
7.3.3	Video OCX Protocol.....	65
7.3.4	Video Frame Rate.....	66
7.3.5	Video Mask	66
7.3.6	Audio (Audio Mode and Bit Rate Settings)	67
7.4	Camera.....	68
7.4.1	Exposure Setting	68
7.4.2	White Balance Setting	70
7.4.3	Picture Adjustment.....	71
7.4.4	Backlight	71
7.4.5	Digital Zoom.....	72
7.4.6	IR Function (Compact Fixed Dome Excluded)	72
7.4.7	WDR Function	73
7.4.8	Noise Reduction	73
7.4.9	TV System Setting	73
7.5	Pan Tilt	74
7.5.1	Preset	74
7.5.2	Sequence	76
7.5.3	Pan/Tilt Control.....	77
7.6	Logout	78
	Appendix A: Technical Specifications.....	79
	Appendix B: Delete the Existing DC Viewer	81
	Appendix C: Setup Internet Security	82
	Appendix E: Install UPnP Components	83

1. Overview





Supported with both H.264 and MJPEG standard, the product series not only features in superior Full HD resolution for real-time streaming at 25/30 fps, but also supplies a full D1 720p real-time Analog stream. With more computing power, the IP Camera will provide more flexibility for users and system managers.

1.1 Features

- Progressive Scan CMOS Sensor
- Dual Streams, Full HD real-time + D1 real-time
- H.264 and MJPEG compression
- Motion Detection
- Privacy Masks
- WDR
- Smart Picture Quality/3DNR
- Tampering Alarm
- Day/Night (ICR)
- Micro SD support
- Weatherproof Dongle Cable (Optional)
- Weatherproof (IP66 international)
- Micro SD support (Optional)
- Security Torx against tampering
- ONVIF Support

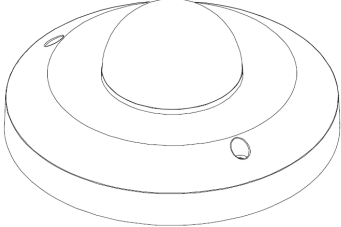
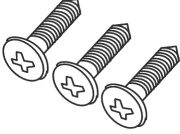
1.2 Package Contents

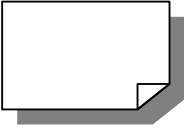
Please check the package contains the following items listed below.

 <p>Indoor Camera/ Rugged Camera (with Cable)</p>	 <p>Self-tapping screws (x3)</p>	 <p>Plastic Anchors (x3)</p>	 <p>Security Torx</p>
 <p>Quick Guide</p>	 <p>CD</p>		



NOTE: The type of the supplied self-tapping screws is mainly for softer substrate/material installation such as wood. For other installation environment such as cement wall, it is required to pre-drill and use plastic anchors before fastening the supplied self-tapping screw on the wall.

1.3 Dimensions

The IP Camera's dimensions are shown below.

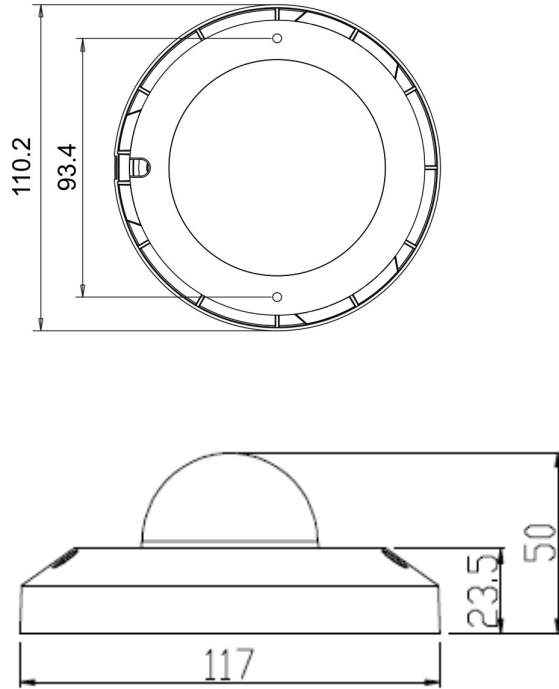

1.4 Connectors

The diagram below shows the IP Dome Camera's reset button and various adjusting screws. Definition for each will be given as follows.

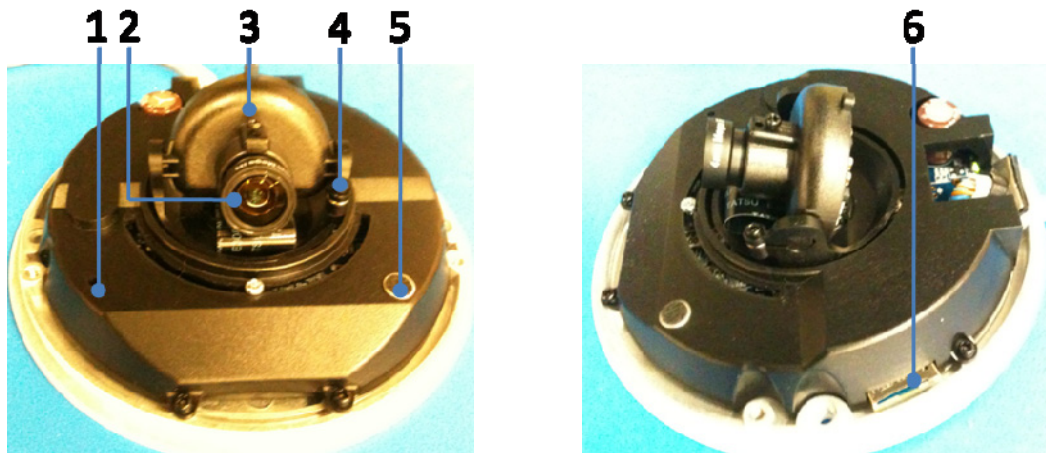

Designation		Description
1	Reset Button	Restore to default setting; press the button with a proper tool
2	Lens	Rotate the lens right/left to adjust focus
3	Focus Fixed Screw	Loosen the screw to adjust the lens
4	Tilt Fixed Screw	Loosen the screw to adjust tilt angle
5	Microphone	For Audio
6	Micro SD Card Slot	For video recording storage

2. Camera Cabling

Please follow the instructions below to complete IP Camera connection.

2.1.1 Indoor Camera

PoE Connection

Connect the one end of the Ethernet cable to the network port on the camera, and the other end to Power Sourcing Equipment (PSE) like hubs or routers.

3. System Requirements

To perform the IP Camera via web browser, please ensure your PC is in good network connection, and meet system requirements as described below.

Items	System Requirement
Personal Computer	1. Intel® Pentium® M, 2.16 GHz or Intel® Core™2 Duo, 2.0 GHz 2. 2 GB RAM or more
Operating System	Windows VISTA/ Windows XP/ Windows 7
Web Browser	Microsoft Internet Explorer 6.0 or later Firefox Chrome Safari
Network Card	10Base-T (10 Mbps) or 100Base-TX (100 Mbps) operation
Viewer	ActiveX control plug-in for Microsoft IE

4. Access Camera

For initial access to the IP Camera, users can search the camera through the installer program: DeviceSearch.exe, which can be found in “DeviceSearch” folder in the supplied CD.

Device Search Software Setup

Step 1: Double click on the program Device Search.exe. After its window appears, click on the <Device Search> button on the top side.

Step 2: The security alert window will pop up. Click on <Unblock> to continue.

Device Search

Step 3: Click on <Device Search> again, and all the finding IP devices will be listed in the page. The IP Camera’s default IP address is: **192.168.0.250**.

Step 4: Double click or right click and select <Browse> to access the camera directly via web browser.

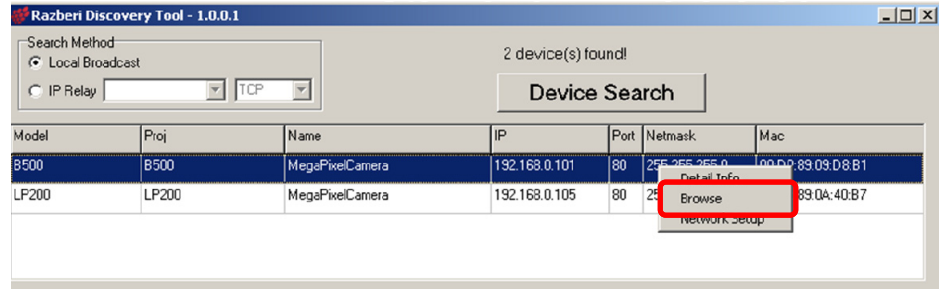

Step 5: Enter the default username and password.

The default Administrator login ID and password:

Login ID	Password
Admin	1234



NOTE: Login ID and password are case sensitive.



NOTE: It is strongly advised that the administrator’s password be altered for security concerns. Refer to System Menu for

further details.

Additionally, users can change the IP Camera's network property, either DHCP or Static IP, directly in the device finding list. Refer to the following section for changing the IP Camera's network property.

Example of Changing the IP Camera Network Property to DHCP:

Step 1: In the finding device list, click on the desired IP Camera to change its network property. Record the IP Camera's MAC address for future identification. On the selected item, right click and select "Network Setup."



Step 2: The "Network Setup" page will pop up. Select "DHCP," and press "Apply" button down the page.

Step 3: Click on <OK> on the Note of setting change. Wait for one minute before continuing.

Step 4: Click on the <Device Search> button to search all the devices. Then select the IP Camera with the correct MAC address. Double click on the IP Camera, and the login window will pop up.

Step 5: Enter User name and Password to access the IP Camera.

Installing DC Viewer Software Online

For the initial access to the IP Camera, a client program, DC Viewer, will be automatically installed to your PC when connecting to the IP Camera.

If the Web browser doesn't allow DC Viewer installation, please check the Internet security settings or ActiveX controls and plug-ins settings (refer to [Section: Setup Internet Security](#)) to continue the process.

The Information Bar (just below the URL bar) may come out and ask for permission to install the ActiveX Control for displaying video in browser. Right click on the Information Bar and select <Install ActiveX Control...> to allow the installation.

The download procedure of DC Viewer software is specified as follows.

Step 1: In the DC Viewer installation window, click on <Next> to start installation.

Step 2: The status bar will show the installation progress. After the installation is completed, click on <Finish> to exit the installation process.

Step 3: Click on <Finish> to close the DC Viewer installation page.

Once the DC Viewer is successfully installed, the IP Camera's Home page will be able to correctly display as the figure below.

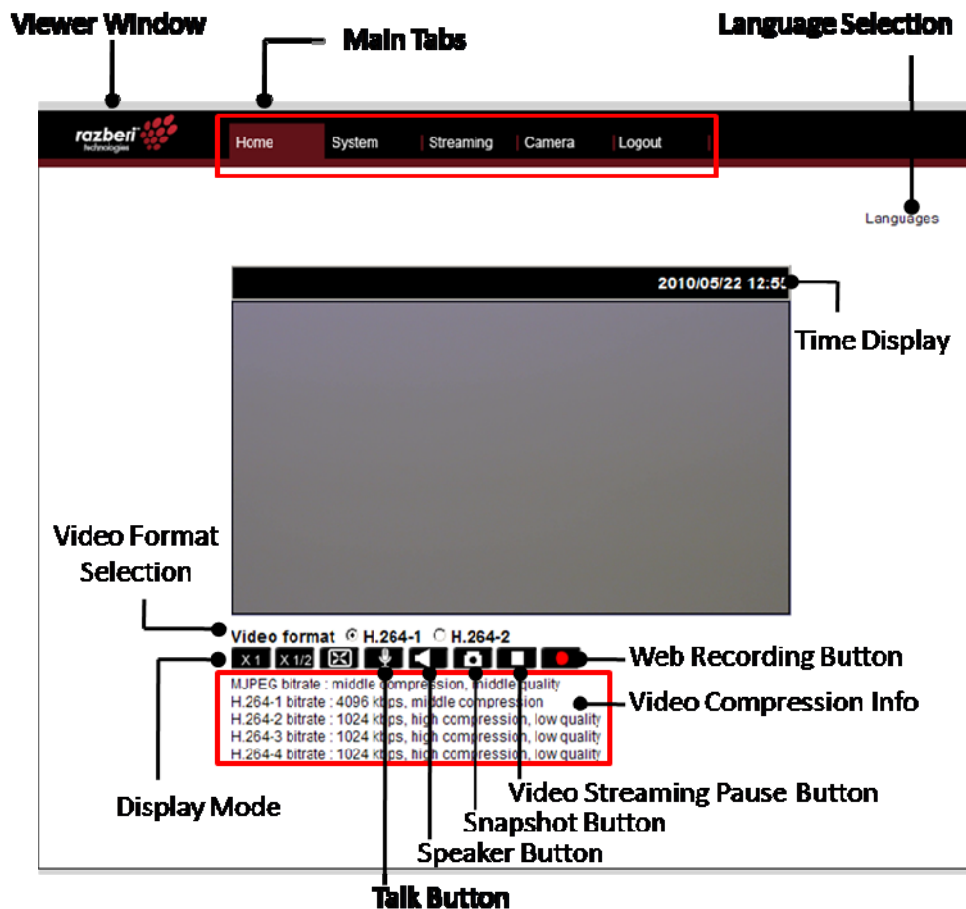

Image and Focus Adjustment

The image displays on the Home page when successfully accessing to the IP Camera. Adjust zoom and focus as necessary to produce a clear image.



Note: Please refer to [Full HD Multiple Streams IP Camera Menu Tree](#) for more button function detail.

5. Setup Video Resolution

Users can setup Video Resolution on the Video Format page of the user-friendly browser-based configuration interface.

Video Format can be found under this path: **Streaming> Video Format**.

The screenshot displays the Razberi Technologies web interface for configuring video settings. The navigation menu at the top includes 'Home', 'System', 'Streaming', 'Camera', and 'Logout'. The 'Streaming' menu item is highlighted with a red box. Below the navigation, the 'Video Format' page title is also highlighted with a red box. The main content area is titled 'Video Format' and contains several sections:

- Video Resolution:** A dropdown menu is set to 'H.264 + H.264'. Below it, 'H.264-1 format' is set to '1920 x 1080 (30 fps)' and 'H.264-2 format' is set to '720 x 480 (30 fps)'. 'BNC support' is set to 'Yes'. A 'Save' button is present.
- Note:** A note states: 'Image attachment by FTP or E-mail will be available only while MJPEG streaming is selected.'
- Text Overlay Settings:** Includes checkboxes for 'Include date', 'Include time', and 'Include text string'. A text input field is provided for the text string. A 'Save' button is present.
- Video Rotate Type:** A dropdown menu is set to 'Normal video'. A 'Save' button is present.
- GOV Settings:** Includes input fields for 'H.264-1 GOV Length' (60), 'H.264-2 GOV Length' (60), 'H.264-3 GOV Length' (30), and 'H.264-4 GOV Length' (30). A 'Save' button is present.
- H.264 Profile:** Includes dropdown menus for 'H.264-1' (Main profile), 'H.264-2' (Main profile), 'H.264-3' (Main profile), and 'H.264-4' (Main profile). A 'Save' button is present.

Click on <Save> to confirm the setting.

2M Model

- **Video Format**

Under Video Resolution section, select a preferred resolution setting.
The available Video Resolution for MJPEG & H.264 format includes:

H.264 + H.264		
H.264-1	H.264-2	BNC SUPPORT
1920 x 1080 (15fps)	1280 x 720 (30fps)*	-
	1024 x 768 (30fps)	-
	800 x 600 (30fps)	-
	720 x 480 (30fps)	-
	640 x 480 (30fps)	-
	352 x 240 (30fps)	-
1280 x 1024 (30fps)	1280 x 1024 (15fps)	-
	1280 x 720 (15fps)	-
	1024 x 768 (15fps)	-
	800 x 600 (30fps)	-
	720 x 480 (30fps)	-
	640 x 480 (30fps)	-
	352 x 240 (30fps)	-
1280 x 720 (30fps)	1280 x 720 (30fps)	-
	1024 x 768 (30fps)	-
	800 x 600 (30fps)	-
	720 x 480 (30fps)	-
	640 x 480 (30fps)	-
	352 x 240 (30fps)	-
1024 x 768 (30fps)	1024 x 768 (30fps)	-
	800 x 600 (30fps)	-
	720 x 480 (30fps)	-
	640 x 480 (30fps)	-
	352 x 240 (30fps)	-
800 x 600 (30fps)	800 x 600 (30fps)	-
	720 x 480 (30fps)	-
	640 x 480 (30fps)	-
	352 x 240 (30fps)	-

720 x 480 (30fps)	720 x 480 (30fps)	-
	640 x 480 (30fps)	-
	352 x 240 (30fps)	-
640 x 480 (30fps)	640 x 480 (30fps)	-
	352 x 240 (30fps)	-
352 x 240 (30fps)	352 x 240 (30fps)	-
H.264 + MJPEG		
H.264	MJPEG	BNC SUPPORT
1920 x 1080 (15fps)	1280 x 720 (30fps)	-
	1024 x 768 (30fps)	-
	800 x 600 (30fps)	-
	720 x 480 (30fps)	-
	640 x 480 (30fps)	-
	352 x 240 (30fps)	-
1280 x 1024 (30fps)	1280 x 1024 (15fps)	-
	1280 x 720 (15fps)	-
	1024 x 768 (15fps)	-
	800 x 600 (30fps)	-
	720 x 480 (30fps)	-
	640 x 480 (30fps)	-
	352 x 240 (30fps)	-
1280 x 720 (30fps)	1280 x 720 (30fps)	-
	1024 x 768 (30fps)	-
	800 x 600 (30fps)	-
	720 x 480 (30fps)	-
	640 x 480 (30fps)	-
	352 x 240 (30fps)	-
1024 x 768 (30fps)	1024 x 768 (30fps)	-
	800 x 600 (30fps)	-
	720 x 480 (30fps)	-
	640 x 480 (30fps)	-
	352 x 240 (30fps)	-
800 x 600 (30fps)	800 x 600 (30fps)	-
	720 x 480 (30fps)	-
	640 x 480 (30fps)	-
	352 x 240 (30fps)	-

720 x 480 (30fps)	720 x 480 (30fps)	-
	640 x 480 (30fps)	-
	352 x 240 (30fps)	-
640 x 480 (30fps)	640 x 480 (30fps)	-
	352 x 240 (30fps)	-
352 x 240 (30fps)	352 x 240 (30fps)	-
MJPEG Only		
MJPEG		BNC SUPPORT
	1920 x 1080 (15fps)	-
	1280 x 1024 (30fps)	-
	1280 x 720 (30fps)	-
	1024 x 768 (30fps)	-
	800 x 600 (30fps)	-
	720 x 480 (30fps)	-
	640 x 480 (30fps)	-
	352 x 240 (30fps)	-
H.264 Only		
H.264		BNC SUPPORT
	1920 x 1080 (15fps)	-
	1280 x 1024 (30fps)	-
	1280 x 720 (30fps)	-
	1024 x 768 (30fps)	-
	800 x 600 (30fps)	-
	720 x 480 (30fps)	-
	640 x 480 (30fps)	-
	352 x 240 (30fps)	-

(*) Default

Click on <Save> to confirm the setting.

2M Real-time Model

- **Video Format**

Under Video Resolution section, select a preferred resolution setting.
The available Video Resolution for MJPEG & H.264 format includes:

H.264 + H.264		
H.264-1	H.264-2	BNC SUPPORT
1920 x 1080 (30fps)	720 x 480 (30fps)*	-
	640 x 480 (30fps)	-
	352 x 240 (30fps)	-
1920 x 1080 (15fps)	1920 x 1080 (15fps)	-
	1280 x 1024 (30fps)	-
	1280 x 720 (30fps)	-
	1024 x 768 (30fps)	-
	800 x 600 (30fps)	-
1280 x 1024 (30fps)	1280 x 1024 (15fps)	-
	1280 x 720 (30fps)	-
	1024 x 768 (30fps)	-
	800 x 600 (30fps)	-
	720 x 480 (30fps)	-
	640 x 480 (30fps)	-
	352 x 240 (30fps)	-
1280 x 720 (30fps)	1280 x 720 (30fps)	-
	1024 x 768 (30fps)	-
	800 x 600 (30fps)	-
	720 x 480 (30fps)	-
	640 x 480 (30fps)	-
	352 x 240 (30fps)	-
1024 x 768 (30fps)	1024 x 768 (30fps)	-
	800 x 600 (30fps)	-
	720 x 480 (30fps)	-
	640 x 480 (30fps)	-
	352 x 240 (30fps)	-
800 x 600 (30fps)	800 x 600 (30fps)	-
	720 x 480 (30fps)	-
	640 x 480 (30fps)	-
	352 x 240 (30fps)	-

720 x 480 (30fps)	720 x 480 (30fps)	-
	640 x 480 (30fps)	-
	352 x 240 (30fps)	-
640 x 480 (30fps)	640 x 480 (30fps)	-
	352 x 240 (30fps)	-
352 x 240 (30fps)	352 x 240 (30fps)	-
H.264 + MJPEG		
H.264	MJPEG	BNC SUPPORT
1920 x 1080 (30fps)	720 x 480 (30fps)	-
	640 x 480 (30fps)	-
	352 x 240 (30fps)	-
1920 x 1080 (15fps)	1920 x 1080 (15fps)	-
	1280 x 1024 (30fps)	-
	1280 x 720 (30fps)	-
	1024 x 768 (30fps)	-
	800 x 600 (30fps)	-
1280 x 1024 (30fps)	1280 x 1024 (15fps)	-
	1280 x 720 (30fps)	-
	1024 x 768 (30fps)	-
	800 x 600 (30fps)	-
	720 x 480 (30fps)	-
	640 x 480 (30fps)	-
	352 x 240 (30fps)	-
1280 x 720 (30fps)	1280 x 720 (30fps)	-
	1024 x 768 (30fps)	-
	800 x 600 (30fps)	-
	720 x 480 (30fps)	-
	640 x 480 (30fps)	-
	352 x 240 (30fps)	-
1024 x 768 (30fps)	1024 x 768 (30fps)	-
	800 x 600 (30fps)	-
	720 x 480 (30fps)	-
	640 x 480 (30fps)	-
	352 x 240 (30fps)	-

800 x 600 (30fps)	800 x 600 (30fps)	-
	720 x 480 (30fps)	-
	640 x 480 (30fps)	-
	352 x 240 (30fps)	-
720 x 480 (30fps)	720 x 480 (30fps)	-
	640 x 480 (30fps)	-
	352 x 240 (30fps)	-
640 x 480 (30fps)	640 x 480 (30fps)	-
	352 x 240 (30fps)	-
352 x 240 (30fps)	352 x 240 (30fps)	-
MJPEG Only		
MJPEG		BNC SUPPORT
	1920 x 1080 (30fps)	-
	1280 x 1024 (30fps)	-
	1280 x 720 (30fps)	-
	1024 x 768 (30fps)	-
	800 x 600 (30fps)	-
	720 x 480 (30fps)	-
	640 x 480 (30fps)	-
	352 x 240 (30fps)	-
H.264 Only		
H.264		BNC SUPPORT
	1920 x 1080 (30fps)	-
	1280 x 1024 (30fps)	-
	1280 x 720 (30fps)	-
	1024 x 768 (30fps)	-
	800 x 600 (30fps)	-
	720 x 480 (30fps)	-
	640 x 480 (30fps)	-
	352 x 240 (30fps)	-

(*) Default

Click on <Save> to confirm the setting.

6. Configuration Files Export/ Import

To export/ import configuration files, users can access the Maintenance page on the user-friendly browser-based configuration interface.

The Maintenance setting can be found under this path: **System> Maintenance**.

Users can export configuration files to a specified location and retrieve data by uploading an existing configuration file to the IP Camera.

Export

Users can save the system settings by exporting the configuration file (.bin) to a specified location for future use. Click on the <Export> button, and the popup File Download window will come out. Click on <Save> and specify a desired location for saving the configuration file.

Upload

To copy an existing configuration file to the IP Camera, please first click on <Browse> to select the configuration file, and then click on the <Upload> button for uploading.

7. Menu Tree

There are six main tabs including <Home>, <System>, <Streaming>, <Camera>, <Pan Tilt> and <Logout> on the Home Page.

Home

Users can monitor live video of the targeted area.

System setting

The administrator can set host name, system time, root password, network related settings, etc. Further details will be interpreted in chapter [System](#).

Streaming setting

The administrator can modify video resolution and rotate type and select audio compression mode in this page.

Camera setting

Users can adjust various camera parameters, including <Exposure>, <White Balance>, <Picture Adjustment>, <Backlight>, <Digital Zoom>, <IR Function>, <WDR Function>, <Noise Reduction> and <TV System>.

Pan Tilt setting

Users can activate the pan/ tilt function and select the RS-485 protocol which the Pan Tilt Head uses in the <Pan/ Tilt Control> page.



NOTE: Pan Tilt function is only available for 10x/ 18x Zoom AF IP Camera and Box Camera. (DC12V/ AC24V/PoE Model)

Logout

Click on the tab to re-login the IP Camera with another username and password.

7.1 Home Page

Click on the tab <Home> to access the Home Page. There are several function buttons on the Home page. Detailed information of each item is as described in the following chapter.

7.1.1 Function Items on Home Page

Multiple Languages Support

Multiple languages are supported, including German, English, French, Italian, Korean, Simplified Chinese, Traditional Chinese, Russian, etc. for the viewer window interface.

Digital Zoom Control

In the full screen mode, users can implement digital PTZ by rotating the mouse wheel (for zoom in/ out), and drag the mouse into any direction.

Screen Size Adjustment

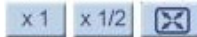

Image display size can be adjusted to x1/2 and full screen.

Talk button



(on/off)

Talk function allows the local site to talk to the remote site. Click on the button to switch it to on/off. Please refer to [Security: Add user > Talk/Listen](#) for further details. This function is only open to “User” who has been granted this privilege by the Administrator.

Speaker button



(on/off)

Click on the <Speaker> button to mute/activate the audio.



NOTE: This function is only available for User who has granted this privilege by the Administrator.

Snapshot button



Click on the button and the JPEG snapshots will automatically be saved in the appointed place. The default place of saving snapshots is: C:\. To change the storage location, please refer to [File Location](#) for further details.



NOTE: For users with Windows 7 operating system, it is required to log on as an Administrator to implement the Snapshot function.

Video Streaming Pause /Restart button   (pause/restart)

Click on the <stop> button to disable video streaming, the live video will be displayed as black. Click on the <restart> button to show the live video again.



Web Recording button   (on/off)

Click on the <Recording> button and the Live View through the web browsing will be directly recorded to the specific location on the local hard drive, which could be configured in the <File Location> page. The default storage location for the web recording is: C:\. Please refer to [File Location](#) for further details.





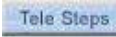
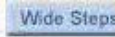

NOTE: For users with Windows 7 operating system, it is required to log on as an Administrator to implement the Web Recording function.

Zoom Adjustment





- **Tele/Wide buttons**  
Hold the <Tele/Wide> button, and implement continuous zoom adjustment.
- **Tele/Wide Steps buttons**  
Click on the <Tele/Wide Steps> buttons will lead zoom to be shifted toward Tele/Wide sides in user-defined range, which can be selected from the drop-down menu.

Manual Focus Adjustment

- **Manual button** 
Click on the <Manual> button, and users can adjust focus manually via the Near/Far buttons at the right side of Manual button.
- **Near/Far buttons**  
Hold the <Near/Far> button, and implement continuous focus adjustment.
- **Near/Far Steps buttons**  
Click on the <Near/Far> buttons will lead focus to be altered toward Near/Far sides in user-defined range, which can be selected from the drop-down menu.

Auto Focus (AF) Adjustment

The AF mode can be defined as of automatic, zoom triggered and one-push.

- **Auto (Continuous AF)** 
In this mode, the camera will keep in focus automatically and continuously regardless of zoom changes or any view changes.
- **Zoom AF (Zoom Trigger AF)** 
In this mode, AF is activated at the time when zoom is adjusted.
- **Push AF** 
The one-push AF function is for fixing the focus on the target in a shot using AF. Once click on the button, AF will be implemented.
- **Reset button** 
Click on the <Reset> button, and the camera lens will be calibrated at full wide end and infinity focus at once.

7.1.2 Function Differences between Models

Below table tells the model differences you will find on the home page. “√” indicates functions can be found on the model you bought. “A-F” each indicates a model type, “a-b” indicate different lens as shown below:

- A. Full HD Multiple Streams Box IP Camera
- B. 10x/18x Zoom AF IP Camera
- C. Full HD Multiple Streams Vandal Proof Fixed Dome IP Camera
- D. Full HD Multiple Streams Lightweight Fixed Dome IP Camera
- E. Full HD Multiple Streams IR Bullet IP Camera
- F. Full HD Multiple Streams Compact Fixed Dome IP Camera

* **a.** Vari-focal Lens; **b.** Motorized Lens; **c.** Fixed-focal Lens

Model Function		A	B	C		D		E			F
				a	b	a	b	a	b	c	
Multiple Language		√	√	√	√	√	√	√	√	√	√
Digital Zoom Control		√	√	√	√	√	√	√	√	√	√
Screen Size Adjustment		√	√	√	√	√	√	√	√	√	√
Talk (On/Off)		√	√	√	√	√	√	√	√	-	-
Speaker (On/Off)		√	√	√	√	√	√	√	√	√	√
Snapshot		√	√	√	√	√	√	√	√	√	√
Video Streaming Pause/ Restart		√	√	√	√	√	√	√	√	√	√
Web Recording (On/Off)		√	√	√	√	√	√	√	√	√	√
Zoom Adjustment	Tele/ Wide	-	√	-	√	-	√	-	√	-	-
	Tele Steps/ Wide Steps	-	-	-	√	-	√	-	√	-	-
	Reset	-	-	-	√	-	√	-	√	-	-
	Manual	-	√	-	-	-	-	-	-	-	-
Manual Focus Adjustment	Near/ Far	-	√	-	√	-	√	-	√	-	-
	Near Steps/ Far Steps	-	-	-	√	-	√	-	√	-	-
	Reset	-	-	-	√	-	√	-	√	-	-
	Auto	-	√	-	-	-	-	-	-	-	-
Auto Focus Adjustment	Zoom AF	-	√	-	-	-	-	-	-	-	-
	Push AF	-	√	-	√	-	√	-	√	-	-

7.2 System

Under the tab <**System**>, there are submenus including: <System>, <Security>, <Network>, <DDNS>, <Mail>, <FTP>, <HTTP>, <Application>, <Motion Detection>, <Tampering>, <Storage Management>, <Recording>, <File Location>, <Iris Adjustment>, <View Log File>, <View User Information>, <View Parameters>, <Factory Default>, <Software Version>, <Software Upgrade>, and <Maintenance>.



NOTE: The System configuration page is only accessible by the Administrator.

7.2.1 System

The System Setting can be found under the path: **System> System**.

Host Name

The name is for camera identification. If alarm function (refer to [Application](#)) is enabled and is set to send alarm message by Mail/FTP, the host name entered here will display in the alarm message. The maximum length of the Host Name is 30 characters.

Time Zone

Select the time zone you are in from the drop-down menu.

Enable Daylight Saving Time

To enable DST, please check the item and then specify time offset and DST duration. The format for time offset is [hh:mm:ss]; for instance, if the amount of time offset is one hour, please enter "01:00:00" into the field.

Sync With Computer Time

Select the item, and video date and time display will synchronize with the PC's.

Manual

The Administrator can set video date, time and day manually. Entry format should be identical with that shown next to the enter fields.

Sync with NTP server

Network Time Protocol (NTP) is an alternate way to synchronize your camera's clock with a NTP server. Please specify the server you wish to synchronize in the enter field. Then select an update interval from the drop-down menu. For further information about NTP, please refer to the web site: www.ntp.org.

7.2.2 Security

The Security setting can be found under this path: **System> Security**.

Click on the Security category, there will be a drop-down menu with tabs including <User>, <HTTPS>, <IP Filter>, and <IEEE 802.1X>.

7.2.2.1 User

The User setting can be found under this path: **System> Security> User**.

Admin Password

Change the administrator's password by inputting the new password in both text boxes. The input characters/numbers will be displayed as dots for security purposes. After clicking on <Save>, the web browser will ask the Administrator for the new password for accessing. The maximum length of the password is 14 characters.



NOTE: The following characters are valid: A-Z, a-z, 0-9, !#\$%&'-.@^_~.

Add user

Type the new user's name and password and click on <Add> to add the new user. User name can be up to 16 characters, and the maximum length of the password is 14 characters. The new user will be displayed in the user name list. There is a maximum of twenty user accounts. Each user can be assigned the privileges of “**Camera control**”, “**Talk**” and “**Listen**”.

- **I/O access**
This item supports fundamental functions that enable users to view video when accessing to the camera.
- **Camera control**
This item allows the appointed User to change camera parameters on the Camera Setting page.
- **Talk/Listen**
Talk and Listen functions allow the appointed user in the local site (PC site) communicating with, for instance, the administrator in the remote site.

Manage User

- **Delete user**

To delete a user, pull down the user list, and select the user name you wish to delete. Then click on <Delete> to remove it.

- **Edit user**

Pull down the user list and select a user name. Click on <Edit> to edit the user's password and privilege.



NOTE: It is required to enter the User password as well as check the function items which will be available for the user. When finished, click on <Save> to modify the account authority.

7.2.2.2 HTTPS

The HTTPS setting can be found under this path: **System> Security> HTTPS**.

<HTTPS> allows secure connections between the IP Camera and web browser using <Secure Socket Layer (SSL)> or <Transport Layer Security (TLS)>, which ensure camera settings or Username/ Password info from snooping. It is required to install a self-signed certificate or a CA-signed certificate for implementing <HTTPS>.

To use HTTPS on the IP Camera, a HTTPS certificate must be installed. The HTTPS certificate can be obtained by either creating and sending a certificate request to a Certificate Authority (CA) or creating a self-signed HTTPS certificate, as described below.

Create Self-signed Certificate

Before a CA-issued certificate is obtained, users can create and install a self-signed certificate first.

Click on <Create> button under “Create self-signed certificate” and provide the requested information to install a self-signed certificate for the IP Camera. Please refer to the last part of this section: [Provide the Certificate Information](#) for more details.



NOTE: The self-signed certificate does not provide the same high level of security as when using a CA-issued certificate.

Install Signed Certificate

Click on the <Create Certificate Request> button to create and submit a certificate request in order to obtain a signed certificate from CA.

Provide the request information in the create dialog. Please refer to the following [Provide the Certificate Information](#) for more details.

When the request is complete, the subject of the Created Request will be shown in the field. Click on <Properties> below the Subject field, copy the PEM-formatted request and send it to your selected CA.

When the signed certificate is returned, install it by uploading the signed certificate.

Provide the Certificate Information

To create a Self-signed HTTPS Certificate or a Certificate Request to CA, please enter the information as requested:

	Create Self Signed Certificate	Create Certificate Request
Country	√	√
State or Province	√	√
Locality	√	√
Organization	√	√
Organizational Unit	√	√
Common Name	√	√
Valid Day	√	-

- **Country**
Enter a 2-letter combination code to indicate the country the certificate will be used in. For instance, type in "US" to indicate United States.
- **State or province**
Enter the local administrative region.
- **Locality**
Enter other geographical information.
- **Organization**

Enter the name of the organization to which the entity identified in “Common Name” belongs.

- **Organization Unit**

Enter the name of the organizational unit to which the entity identified in “Common Name” belongs.

- **Common Name**

Indicate the name of the person or other entity that the certificate identifies (often used to identify the website).

- **Valid days**

Enter the period in days (1~9999) to indicate the valid period of certificate.

Click on <OK> to save the Certificate Information after complete.

7.2.2.3 IP Filter

The IP Filter setting can be found under this path: **System> Security> IP Filter**.

Using the IP filter, access to the IP Camera can be restricted by denying/allowing specific IP addresses.

- **Enable IP Filter**

Check the box to enable the IP Filter function. Once enabled, the listed IP addresses (IPv4) will be allowed/ denied access to the IP Camera.

Select <Allow> or <Deny> from the drop-down list and click on the <Apply> button to determine the IP Filter behavior.

- **Add/ Delete IP Address**

Input the IP address and click on the <Add> button to add a new filtered address.

The Filtered IP Addresses list box shows the currently configured IP addresses. Up to 256 IP address entries may be specified.

To remove an IP address from the list, please select the IP and then click on the <Delete> button.

7.2.2.4 IEEE 802.1X

The IEEE 802.1X setting can be found under this path: **System> Security> IEEE 802.1X.**

The IP Camera is allowed to access a network protected by 802.1X/EAPOL (Extensible Authentication Protocol over LAN).

Users need to contact with the network administrator for gaining certificates, user IDs and passwords

CA Certificate

The CA certificate is created by the Certification Authority for the purpose of validating itself. Upload the certificate for checking the server's identity.

Client Certificate/ Private Key

Upload the Client Certificate and Private Key for authenticating the IP Camera itself.

Settings

- **Identity**
Enter the user identity associated with the certificate. Up to 16 characters can be used.
- **Private Key Password**
Enter the password (maximum 16 characters) for your user identity.

Enable IEEE 802.1X

Check the box to enable IEEE 802.1X.

Click on <Save> to save the IEEE 802.1X/ EAP- TLS setting.

7.2.3 Network

The Network setting can be found under this path: **System> Network**.

Click on the <Network> category, there will be a drop-down menu with tabs including <Basic>, <QoS>, <SNMP>, and <UPnP>.

7.2.3.1 Basic

The Basic setting can be found under this path: **System> Network> Basic**.

Users can choose to connect to the IP Camera with fixed or dynamic (DHCP) IP address. The IP Camera also provides PPPoE support for users who connect to the network via PPP over Ethernet (PPPoE).

General

- **Get IP address automatically (DHCP)**

The camera's default setting is <Use fixed IP address>. Please refer to User's Manual for login with the default IP address.

If select <Get IP address automatically>, after the IP Camera restarts, users can search it through the installer program: DeviceSearch.exe, which can be found in "DeviceSearch" folder in the supplied CD.



NOTE: Please make the record of the IP Camera's MAC address, which can be found in the label of the camera, for identification in the future.

- **Use fixed IP address**

To setup static IP address, select <Use fixed IP address> and move the cursor to the IP address blank and insert the new IP address, ex. 192.168.7.123; then go to the Default gateway (explained later) blank and change the setting, ex. 192.168.7.254. Click on <Save> to confirm the new setting.

When using static IP address to login to the IP Camera, users can access it either through "DeviceSearch" software (refer to User's Manual) or input the IP address in the URL bar and click on <Enter>.

➤ IP address

- This is necessary for network identification.
- Subnet mask
It is used to determine if the destination is in the same subnet. The default value is “255.255.255.0”.

 - Default gateway
This is the gateway used to forward frames to destinations in different subnet. Invalid gateway setting will fail the transmission to destinations in different subnet.

 - Primary DNS
Primary DNS is the primary domain name server that translates hostnames into IP addresses.

 - Secondary DNS
Secondary DNS is a secondary domain name server that backups the primary DNS.

Use PPPoE

For the PPPoE users, enter the PPPoE Username and Password into the fields, and click on the <Save> button to complete the setting.

Advanced

- **Web Server port**
The default web server port is 80. Once the port is changed, the user must be notified the change for the connection to be successful. For instance, when the Administrator changes the HTTP port of the IP Camera whose IP address is 192.168.0.100 from 80 to 8080, the user must type in the web browser “<http://192.168.0.100:8080>” instead of “<http://192.168.0.100>”.

- **RTSP port**
The default setting of RTSP Port is 554; the setting range is from 1024 to 65535.

- **MJPEG over HTTP port**
The default setting of MJPEG over HTTP Port is 8008; the setting range is from 1024 to 65535.

- **HTTPS port**

The default setting of HTTPS Port is 443; the setting range is from 1024 to 65535.



NOTE: Be aware to choose the different port from the one set for the web server port.

IPv6 Address Configuration

With IPv6 support, users can use the corresponding IPv6 address for browsing. Enable IPv6 by checking the box and click on <Save> to complete the setting.

7.2.3.2 QoS

The QoS (Quality of Service) setting can be found under this path: **System> Network> QoS**.

QoS allows providing differentiated service levels for different types of traffic packets, which guarantees delivery of priority services especially when network congestion occurs. Adapting the Differentiated Services (DiffServ) model, traffic flows are classified and marked with DSCP (DiffServ Codepoint) values, and thus receive the corresponding forwarding treatment from DiffServ capable routers.

DSCP Settings

The DSCP value range is from 0 to 63. The default DSCP value is 0, which means DSCP is disabled. The IP Camera uses the following QoS Classes: Video, Audio and Management.

- **Video DSCP**

The class consists of applications such as MJPEG over HTTP, RTP/RTSP and RTSP/HTTP.

- **Audio DSCP**

This setting is only available for the IP Cameras that support audio.

- **Management DSCP**

The class consists of HTTP traffic: Web browsing.



NOTE: To enable this function, please make sure the switches/ routers in the network support QoS.

7.2.3.3 **SNMP**

The SNMP (Simple Network Management Protocol) setting can be found under this path: **System> Network> SNMP**.

With Simple Network Management Protocol (SNMP) support, the IP Camera can be monitored and managed remotely by the network management system.

SNMP v1/ v2

- **Enable SNMP v1/ v2**
Select the version of SNMP to use by checking the box.
- **Read Community**
Specify the community name that has read-only access to all supported SNMP objects. The default value is “public”.
- **Write Community**
Specify the community name that has read/write access to all supported SNMP objects (except read-only objects). The default value is “write”.

Traps for SNMP v1/ v2

Traps are used by the IP Camera to send messages to a management system for important events or status changes.

- **Enable Traps**
Check the box to activate trap reporting.
- **Trap address**
Enter the IP address of the management server.
- **Trap community**
Enter the community to use when sending a trap message to the management system.

Trap Option

- **Warm Start**
A Warm Start SNMP trap signifies that the SNMP device, i.e. IP Camera, performs software reload.

Click on <Save> button when complete.

7.2.3.4 UPnP

The UPnP setting can be found under this path: **System> Network> UPnP**.

UPnP Setting

- **Enable UPnP**

When the UPnP is enabled, whenever the IP Camera is presented to the LAN, the icon of the connected IP Cameras will appear in My Network Places to allow for direct access.



NOTE: To enable this function, please make sure the UPnP component is installed on your computer. Please refer to [Install UPnP components](#) for UPnP component installation procedure.

- **Enable UPnP port forwarding**

When the UPnP port forwarding is enabled, the IP Camera is allowed to open the web server port on the router automatically.



NOTE: To enable this function, please make sure that your router supports UPnP and it is activated.

- **Friendly name**

Set the name for the IP Camera for identity.

7.2.4 DDNS

The DDNS setting can be found under this path: **System> DDNS**.

Dynamic Domain Name System (DDNS) allows a host name to be constantly synchronized with a dynamic IP address. In other words, it allows those using a dynamic IP address to be associated to a static domain name so others can connect to it by name.

Enable DDNS

Check the item to enable DDNS.

Provider

Select one DDNS host from the provider list.

Host name

Enter the registered domain name in the field.

Username/E-mail

Enter the username or e-mail required by the DDNS provider for authentication.

Password/Key

Enter the password or key required by the DDNS provider for authentication.

7.2.5 Mail

The Mail setting can be found under this path: **System> Mail**.

The Administrator can send an e-mail via Simple Mail Transfer Protocol (SMTP) when motion is detected. SMTP is a protocol for sending e-mail messages between servers. SMTP is a relatively simple, text-based protocol, where one or more recipients of a message are specified and the message text is transferred.

Two sets of SMTP can be configured. Each set includes SMTP Server, Account Name, Password and E-mail Address settings. For SMTP server, contact your network service provider for more specific information.

7.2.6 FTP

The FTP setting can be found under this path: **System> FTP**.

The Administrator can set as sending alarm message to a specific File Transfer Protocol (FTP) site when motion is detected. Users can assign alarm message to up to two FTP sites. Enter the FTP details, which include server, server port, user name, password and remote folder, in the fields.

Click on <Save> when finished.

7.2.7 HTTP

The HTTP setting can be found under this path: **System> HTTP**.

A HTTP Notification server can listen for notification messages from IP Cameras by triggered events. Enter the HTTP details, which include server name (for instance, <http://192.168.0.1/admin.php>), user name, and password in the fields. <Alarm> triggered and <Motion Detection> notifications can be sent to the specified HTTP server.

Click on <Save> when finished.



Please refer to: [Application> Send HTTP notification/ Motion Detection](#) for HTTP Notification settings.

7.2.8 Application (Compact Fixed Dome Excluded)

The Application setting can be found under this path: **System> Application**.

The IP Camera equips one alarm input and one relay output for cooperating with alarm system to catch events' images. Refer to alarm pin definition below to connect alarm devices to the IP Camera if needed.

Alarm Pin Definition

Please refer to [User's Manual](#) for Alarm Pin Definition to connect the alarm devices.

Alarm Switch

The Administrator can enable or disable the alarm function.

Alarm Type

Select an alarm type, <Normal close> or <Normal open>, that corresponds with the alarm application.

Alarm Output

Define alarm output signal <high> or <low> as the normal alarm output status according to the current alarm application.

Triggered Action (Multi-option)

The Administrator can specify alarm actions that will take when the alarm is triggered. All options are listed as follows:

- **Enable Alarm Output**
Select the item to enable alarm relay output.
- **IR Cut Filter**
Select the item and the camera's IR cut filter (ICR) will be removed (on) or blocked (off) when alarm input is triggered.



Note: The IR Function (Refer to [IR Function](#)) could not be set as <Auto> mode if this triggered action is enabled.

- **Send Alarm Message by FTP/E-Mail**

The Administrator can select whether to send an alarm message by FTP and/or E-Mail when an alarm is triggered.

- **Upload Image by FTP**

Select this item and the Administrator can assign a FTP site and configure various parameters. When the alarm is triggered, event images will be uploaded to the appointed FTP site.

<Pre-trigger buffer> function allows users to check what happened to cause the trigger. The <Pre-trigger buffer> frame rate could be pre-determined.

On the other hand, <Post-trigger buffer> is for users to upload certain amount of images after the alarm input is triggered.

Check the box <Continue image upload> to upload the triggered images during certain time or keep uploading until the trigger is off. Select <Upload for __sec> and enter the duration in the blank. The images of the duration will be uploaded to FTP when the alarm input is triggered. The setting range is from 1 to 9999 seconds. Select <Upload during the trigger active> to make the images keep being uploaded to FTP during the trigger active until the alarm is released. Set the Image frequency as the upload frame rate. The setting range is from 1 frame to 15 frames.



NOTE: Make sure FTP configuration has been completed. Refer to [FTP](#) for further details.

- **Record Stream to SD Card**

Select the item and the alarm-triggered recording will be saved into your Micro SD card.

Pre-trigger buffer recording function allows users to check what happened to cause the trigger. The pre-trigger buffer time range is from 1 to 3 seconds.

Select <Upload for __ sec> to set the recording duration after alarm is triggered. The setting range is from 1 to 99999 seconds.

Select <Upload during the trigger active> to record the triggered video until the trigger is off.



NOTE: Please make sure the local recording (with Micro SD/SDHC card) is activated so that this function can be implemented. Refer to [Recording](#) for further details.

- **Upload Image by E-Mail**

Select this item and the Administrator can assign an e-mail address and configure various parameters. When the alarm input is triggered, event images will be sent to the appointed e-mail address.

<Pre-trigger buffer> function allows users to check what happened to cause the trigger. The <Pre-trigger buffer> frame rate could be pre-determined.

On the other hand, <Post-trigger buffer> is for users to upload certain amount of images after alarm input is triggered.

Check the box <Continue image upload> to upload the triggered images during certain time or keep uploading until the trigger is off. Select <Upload for __sec> and enter the duration in the blank. The images of the duration will be uploading by E-mail when the alarm input is triggered. The setting range is from 1 to 9999 seconds. Select <Upload during the trigger active> to make the images keep being uploaded to E-mail during the trigger active until the alarm is released. Set the Image frequency as the upload frame rate. The setting range is from 1 frame to 15 frames.



NOTE: Make sure SMTP configuration has been completed. Refer to [Mail](#) for further details.

- **Send HTTP notification**

Check this item, select the destination HTTP address, and specify the parameters for event notifications by <Alarm> triggered. When an alarm is triggered, the notification can be sent to the specified HTTP server.

For instance, if the custom parameter is set as " [action=1&group=2](#)", and the HTTP server name is " [http://192.168.0.1/admin.php](#)", the notification will be sent to HTTP server as " [http://192.168.0.1/admin.php?action=1&group=2](#)" when alarm is triggered.

File Name

Enter a file name in the blank, ex. image.jpg. The uploaded image's file name format can be set in this section. Please select the one that meets your requirements.

- **Add date/time suffix**

File name: imageYYMMDD_HHNNSS_XX.jpg

Y: Year, M: Month, D: Day

H: Hour, N: Minute, S: Second

X: Sequence Number

- **Add sequence number suffix (no maximum value)**

File name: imageXXXXXXXX.jpg

X: Sequence Number

Add sequence number suffix (limited value)

File Name: imageXX.jpg

X: Sequence Number

The file name suffix will end at the number being set. For example, if the setting is up to "10," the file name will start from 00, end at 10, and then start all over again.

- **Overwrite**

The original image in the FTP site will be overwritten by the new uploaded file with a static filename.

Save

After complete all the settings mentions above, please click on <Save> button to save all the settings in this page.

7.2.9 Motion Detection

The Motion Detection setting can be found under this path: **System> Motion Detection**.

Motion Detection function allows detecting suspicious motion and triggering alarms when motion volume in the detected area reaches/exceeds the determined sensitivity threshold value.

In the Motion Detection setting page, there is a frame (**Motion Detection Window**) displayed on the Live Video Pane as the figure below. The Motion Detection Window is for defining the motion detection area. To change the size of the Motion Detection Window, move the mouse cursor to the edge of the frame and draw it outward/inward. Moving the mouse to the center of the frame can shift the frame to the intended location.



Up to 10 Motion Detection Windows can be set. Click on the <add> button under the Live Video Pane to add a Motion Detection Window. To cancel a Motion Detection Window, move the mouse cursor to the selected Window, and click on the <delete> button.

If Motion Detection function is activated, the pop-off window (Motion) with indication of motion will be shown.



When motion is detected, the signals will be displayed on the Motion window as shown below.



Motion Detection

Users are able to turn on/off Motion Detection. Default setting is Off.

Motion Detection Setting

Users could adjust various parameters of Motion Detection in this section.

- **Sampling pixel interval [1-10]:**

The default value is 1. If the value is set as 3, it means within the detection region, system will take one sampling pixel for every 3 pixels by each row and each column (refer to the figure below).

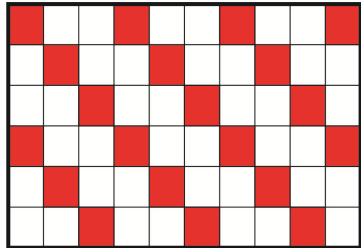

- **Detection level [1-100]:**

The default level is 10. The item is to set detection level for each sampling pixel; the smaller the value, the more sensitive it is.

- **Sensitivity level [1-100]:**

The default level is 80, which means if 20% or more sampling pixels are detected differently, system will detect motion. The bigger the value, the more sensitive it is. Meanwhile, when the value is bigger, the red horizontal line in the motion indication window will be lower accordingly.

- **Time interval (sec) [0-7200]:**

The default interval is 10. The value is the interval between each detected motion.

Triggered Action (Multi-option)

The Administrator can specify alarm actions that will take when motion is detected. All options are listed as follows:

- **Enable Alarm Output**

Check the item and select the predefined type of alarm output to enable alarm relay output when motion is detected.

- **Record stream to SD Card**

Select this item and the Motion Detection recording will be stored in Micro SD/ SDHC card when motion is detected.

Pre-trigger buffer recording function allows users to check what happened to cause the trigger. The pre-trigger buffer time range is from 1 to 3 seconds.

Select <Upload for __ sec> to set the recording duration after motion event occurs. The setting range is from 1 to 99999 seconds.

Select <Upload during the trigger active> to record the triggered video until the trigger is off.



NOTE: Please make sure the local recording (with Micro SD/ SDHC card) is activated so that this function can be implemented. Refer to [Recording](#) for further details.

- **Send Alarm Message by FTP/E-Mail**

The Administrator can select whether to send warning messages by FTP and/or E-Mail when motion is detected.

- **Upload Image by FTP**

Select this item and the Administrator can assign a FTP site and configure various parameters. When motion is detected, event images will be uploaded to the appointed FTP site.

<Pre-trigger buffer> function allows users to check what happened to cause the trigger. The <Pre-trigger buffer> frame rate could be pre-determined.

On the other hand, <Post-trigger buffer> is for users to upload certain amount of images after motion event occurs.

Check the box <Continue image upload> to upload the triggered images during certain time or keep uploading until the trigger is off. Select <Upload for __sec> and enter the duration in the blank. The images of the duration will be uploaded to FTP when the motion event occurs. The setting range is from 1 to 9999 seconds. Select <Upload during the trigger active> to make the images keep being uploaded to FTP during

the trigger active until the event stops. Set the Image frequency as the upload frame rate. The setting range is from 1 frame to 15 frames.



NOTE: Make sure FTP configuration has been completed. Refer to [FTP](#) for further details.

- **Upload Image by E-Mail**

Select this item and the Administrator can assign an e-mail address and configure various parameters. When motion is detected, event images will be sent to the appointed e-mail address.

<Pre-trigger buffer> function allows users to check what happened to cause the trigger. The <Pre-trigger buffer> frame rate could be pre-determined.

On the other hand, <Post-trigger buffer> is for users to upload certain amount of images after the motion event occurs.

Check the box <Continue image upload> to upload the triggered images during certain time or keep uploading until the trigger is off. Select <Upload for __sec> and enter the duration in the blank. The images of the duration will be uploading by E-mail when the motion event occurs. The setting range is from 1 to 9999 seconds. Select <Upload during the trigger active> to make the images keep being uploaded to E-mail during the trigger active until the event stops. Set the Image frequency as the upload frame rate. The setting range is from 1 frame to 15 frames.



NOTE: Make sure SMTP configuration has been completed. Refer to [Mail](#) for further details.

- **Send HTTP notification**

Check this item, select the destination HTTP address, and specify the parameters for event notifications by <Motion Detection> triggered. When an alarm is triggered, the notification can be sent to the specified HTTP server.

For instance, if the custom parameter is set as” [action=1&group=2](#)”, and the HTTP server name is” [http://192.168.0.1/admin.php](#)”, the notification

will be sent to HTTP server as” <http://192.168.0.1/admin.php?action=1&group=2>” when alarm is triggered.

File Name

The uploaded image's filename format can be set in this section. Please select the one that meets your requirements.

Save

Click on the <Save> button to save all the Motion Detection settings mentioned above.

7.2.10 Tampering

The Tampering setting can be found under this path: **System> Tampering**.

Tampering Alarm function helps the IP Camera against tampering such as deliberate redirection, blocking, paint spray, and lens cover, etc through video analysis and reaction to such events by sending out notifications or uploading snapshots to the specified destination(s).

Detection of camera tampering is achieved by measuring the differences between the older frames of video (which are stored in buffers) and more recent frames.

Tampering Alarm

Users are able to turn on/off Tampering Alarm function in Tampering Alarm setting page. The default setting is Off.

Tampering Duration

Minimum Tampering Duration is the time for video analysis to determine whether camera tampering has occurred. Minimum Duration could also be interpreted as defining the Tampering threshold; longer duration represents higher threshold. Settable Tampering Duration time range is from 10 to 3600 seconds. The Default value is 20 seconds.

Triggered Action (Multi-option)

The Administrator can specify alarm actions that will take when tampering is detected. All options are listed as follows:

- **Enable Alarm Output**
Check the item and select the predefined type of alarm output to enable alarm output when tampering is detected.
- **Record stream to SD Card**
Select this item and the Tampering Alarm recording will be stored in Micro SD/ SDHC card when tampering is detected.

Pre-trigger buffer recording function allows users to check what happened to cause the trigger. The pre-trigger buffer time range is from 1 to 3 seconds.

Select <Upload for __ sec> to set the recording duration after tampering occurs. The setting range is from 1 to 99999 seconds.

Select <Upload during the trigger active> to record the triggered video until the trigger is off.



NOTE: Please make sure the local recording (with Micro SD/SDHC card) is activated so that this function can be implemented. Refer to [Recording](#) for further details.

- **Send Alarm Message by FTP/E-Mail**

The Administrator can select whether to send an alarm message by FTP and/or E-Mail when tampering is detected.

- **Upload Image by FTP**

Select this item and the Administrator can assign a FTP site and configure various parameters. When tampering is detected, event images will be uploaded to the appointed FTP site.

<Pre-trigger buffer> function allows users to check what happened to cause the trigger. The <Pre-trigger buffer> frame rate could be pre-determined.

On the other hand, <Post-trigger buffer> is for users to upload certain amount of images after tampering is triggered.

Check the box <Continue image upload> to upload the triggered images during certain time or keep uploading until the trigger is off. Select <Upload for __sec> and enter the duration in the blank. The images of the duration will be uploaded to FTP when tampering is triggered. The setting range is from 1 to 9999 seconds. Select <Upload during the trigger active> to make the images keep being upload to FTP during the trigger active until the tampering stops. Set the Image frequency as the upload frame rate. The setting range is from 1 frame to 15 frames.



NOTE: Make sure FTP configuration has been completed. Refer to [FTP](#) for further details.

- **Upload Image by E-Mail**

Select this item and the Administrator can assign an e-mail address and configure various parameters. When tampering is detected, event images will be sent to the appointed e-mail address.

<Pre-trigger buffer> function allows users to check what happened to cause the trigger. The <Pre-trigger buffer> frame rate could be pre-determined.

On the other hand, <Post-trigger buffer> is for users to upload certain amount of images after tampering occurs.

Check the box <Continue image upload> to upload the triggered images during certain time or keep uploading until the trigger is off. Select <Upload for __sec> and enter the duration in the blank. The images of the duration will be uploading by E-mail when tampering is triggered. The setting range is from 1 to 9999 seconds. Select <Upload during the trigger active> to make the images keep being upload to E-mail during the trigger active until tampering stops. Set the Image frequency as the upload frame rate. The setting range is from 1 frame to 20 frames.



NOTE: Make sure SMTP configuration has been completed. Refer to [Mail](#) for further details.

- **Send HTTP notification**

Check this item, select the destination HTTP address, and specify the parameters for HTTP notifications. When the Tampering Alarm is triggered, the HTTP notifications can be sent to the specified HTTP server.

For instance, if the custom parameter is set as” [action=1&group=2](#)”, and the HTTP server name is” [http://192.168.0.1/admin.php](#)”, the notification will be sent to HTTP server as” [http://192.168.0.1/admin.php?action=1&group=2](#)” when alarm is triggered.

File Name

The uploaded image’s filename format can be set in this section. Please select the one that meets your requirements.

Save

Click on the <Save> button to save all the Tampering Alarm settings mentioned above.

7.2.11 Storage Management (Local Recording)

The Storage Management setting can be found under this path: **System> Storage Management**.

Users can implement local recording to the Micro SD/SDHC card up to 32GB. This page shows the capacity information of the Micro SD card and a recording list with all the recording files saved on the memory card. Users can also format the SD card and implement automatic recording cleanup through the setting page.

To implement Micro SD card recording, please go to the <Recording> page (refer to [Recording](#)) for activation.



NOTE: Please format the Micro SD/SDHC card when using for the first time. Formatting will also be required when a memory card already being used on one camera and later transferred to another camera with different software platform.

Device information

When users insert the Micro SD/SDHC card, the card information such as the memory capacity and status will be shown at Device Information section.

For the memory card being successfully installed, its status shall be shown at <Device information> section in the Storage Management page.

Device setting

Click on the <Format> button to format the memory card.

Disk cleanup setting

Users can enable automatic recordings cleanup by specifying the time and storage limits

Recording List

Each video file on the Micro SD/SDHC card will be listed in the Recording list as shown below. The maximum file size is 60 MB (60 MB per file).

When the recording mode is set as “Always” (consecutive recording) and the Micro SD/ SDHC card recording is also allowed to be enabled by events triggered, once events occur, the system will immediately implement events recording to the memory card. Then the IP Camera will return to the regular recording mode after events recording.

- **Remove**

To remove a file, select the file first, and then click on the <Remove> button.

- **Sort**

Click on the <Sort> button, and the files in the Recording list will be listed in name and date order.



NOTE: The capital letter A/M/R/T appears in the very beginning of name denotes the sort of the recording: A stands for Alarm; M stands for Motion; R stands for regular recording, and T stands for Tampering.

- **Download**

To open/download a video clip, select the file first, and then click on the <download> button below the Recording list field. The selected file window will pop up. Click on the AVI file to directly play the video in the player or download it to a specified location.

7.2.12 Recording (Local Recording)

The Recording setting can be found under this path: **System> Recording**.

In the Recording setting page, users can specify the recording schedule that fits the present surveillance requirement.

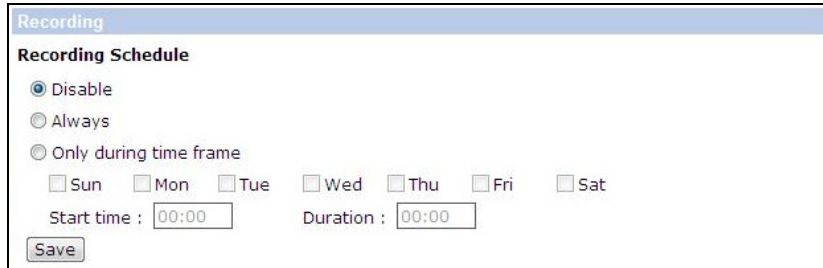

The screenshot shows a web interface for configuring the recording schedule. It is titled "Recording" and has a sub-section "Recording Schedule". There are three radio button options: "Disable" (selected), "Always", and "Only during time frame". Under "Only during time frame", there are checkboxes for each day of the week: Sun, Mon, Tue, Wed, Thu, Fri, and Sat. Below these are two input fields: "Start time : 00:00" and "Duration : 00:00". A "Save" button is located at the bottom left of the form.

Activating Micro SD/SDHC Card Recording

Two types of schedule mode are offered: Always and Time Frame setting. Users can setup the time frame to fit the recording schedule or choose <Always> to activate Micro SD/SDHC Card Recording all the time.

Please click on the <Save> button for confirming the schedule mode.

Terminating Micro SD/SDHC Card Recording

Select <Disable> to terminate the recording function.

7.2.13 File Location (Snapshots and Web Recording)

The File Location setting can be found under this path: **System> File Location**.

Users can specify a storage location on the PC or in the hard drive for the snapshots and live video recording. The default setting is: C:\. Once confirm the setting, click on <Save>, and all the snapshots and web recording will be saved in the designate location.



NOTE: Please make sure the selected file path contains valid characters such as letters and numbers.



NOTE: For users with Windows 7 operating system, it is required to log on as an Administrator to implement the Snapshot and Web Recording function.

7.2.14 Iris Adjustment (Fixed Focal Lens Excluded)

The Iris Adjustment function can be found under this path: **System> Iris Adjustment**.

For users who use Auto-iris lens, when it is required to implement iris adjustment, please refer to the Iris adjustment procedure in the setting page to adjust iris.

7.2.15 View Log File

The View Log File function can be found under this path: **System> View Log File**.

Click on the tab to view the system log file. The content of the file provides useful information about connections after system boot-up.

7.2.16 View User Information

The View User Information function can be found under this path: **System> View User Information**.

The Administrator can view each added user's login information and privileges (refer to [Security](#)).

View User Login Information

All the users in the network will be listed in the <User information> zone as shown below:

User: 4321

It indicates that one user's login username is "User", and the password is "4321".

View User Privilege

Click on <get user privacy> at the bottom of the page, and the Administrator can view each user's privileges as shown below:

User: 1:1:0:1

1:1:0:1= I/O access : Camera control : Talk : Listen (refer to [Security](#))

Therefore, it denotes the user is granted privileges of I/O access, Camera control and Listen.

7.2.17 View Parameters

The View Parameters function can be found under this path: **System> View Parameter**.

Click on this item to view the entire system's parameter setting such as Camera Settings, Mask Information and Network Information.

7.2.18 Factory Default

The Factory Default setting can be found under this path: **System> Factory Default**.

Users can follow the instructions on this page to reset the IP Camera to factory default setting if needed.

Set Default

Click on the <Set Default> button to recall the factory default settings. Then the system will restart in 30 seconds.



NOTE: The IP address will be restored to default.

Reboot

Click on the <Reboot> button, and the system will restart without changing current settings.

7.2.19 Software Version

The Software Version can be found under this path: **System> Software Version**.

The current software version is displayed in the software version page.

7.2.20 Software Upgrade

The Software Upgrade setting can be found under this path: **System> Software Upgrade**.



NOTE: Make sure the upgrade software file is available before carrying out software upgrade.

The procedure of software upgrade is as below:

Step 1. Click on “Browse” and select the binary file to be uploaded, ex. ulmage_userland.



NOTE: Do not change the upgrade file name, or the system will fail to find the file.

Step 2. Pull down the upgrade binary file list and select the file “ulmage+userland.img”

Step 3. Click on the <Upgrade> button. The system will check whether the upgrade file exists or not first, and then begin to upload the upgrade file. Subsequently, the upgrade status bar will display on the page. When it runs to 100%, the upgrade process is finished.

After the upgrade process is finished, the viewer will return to Home page.

Step 4. Close the video browser.

Step 5. Start <Control Panel> on your PC, and then double click on <Add or Remove Programs>. In the <Currently install programs> list, select <DCViewer> and click on the button “Remove” to uninstall the existing DC Viewer.

Step 6. Open a new web browser, re-login the IP Camera, and then allow the automatic download of DC Viewer.

7.2.21 Maintenance

The Maintenance setting can be found under this path: **System> Maintenance**.

Users can export configuration files to a specified location and retrieve data by uploading an existing configuration file to the IP Camera.

Export

Users can save the system settings by exporting the configuration file (.bin) to a specified location for future use. Click on the <Export> button, and the popup File Download window will come out as shown below. Click on <Save> and specify a desired location for saving the configuration file.

Upload

To copy an existing configuration file to the IP Camera, please first click on <Browse> to select the configuration file, and then click on the <Upload> button for uploading.

7.3 Streaming

Under the tab <**Streaming**>, there are submenus including: <Video Format>, <Video Compression>, <Video OCX Protocol>, <Video Frame Rate>, <Video Mask>, and <Audio>.

In the Streaming submenus, the Administrator can configure specific video resolution, video compression mode, video protocol, audio transmission mode, etc. Further details of these settings will be specified in the following sections.

7.3.1 Video Format (Video Resolution and Rotate Type)

The Video Format setting can be found under this path: **Streaming> Video Format**.

Video Format

Under Video Resolution section, the available video resolution formats are including MJPEG and H.264. Please refer to the User's Manual for more combination details.

Click on <Save> to confirm the setting.

Text Overlay Settings

Users can select the items to display data including date/time/text on the live video pane. The maximum length of the string is 20 alphanumeric characters.

Click on <Save> to confirm the Text Overlay setting.

Video Rotate Type

Users can change video display type if necessary. Selectable video rotate types include Normal, Flip, Mirror, 90 degree clockwise, 180 degree rotate and 90 degree counterclockwise.

The following is descriptions for different video rotate type.

- **Flip**
If select <Flip>, the image will be rotated vertically.
- **Mirror**
If select <Mirror>, the image will be rotated horizontally.
- **90 Degree counter-/clockwise**
Selecting <90 Degree Counter-/clockwise> will make the image 90° counter-/clockwise inversed.
- **180 Degree Rotate**
Selecting <180 Degree> will make the image 180° inversed.

Click on <Save> to confirm the setting.

GOV Settings

Users can set the GOV length to determine the frame structure (I-frames and P-frames) in a video stream for saving bandwidth. The setting range is from 2 to 64. Default value is 60, which means there's one I-frame every 60 frames. Longer GOV length means lower I-frame frequency. Click on <Save> to confirm the GOV setting.

7.3.2 Video Compression

The Video Compression setting can be found under this path: **Streaming> Video Compression**.

Users can select a proper MJPEG/H.264 compression mode in the video compression page depending on the application.

MJPEG Q (Quality) factor

Higher value implies higher bit rates and higher visual quality. The default setting of MJPEG Q factor is 35; the setting range is from 1 to 70.

H.264-1/ H.264-2 bit rate

The default setting of H.264-1/H.264-2 is 4096/1024 kbps; the setting range for H.264-1 is from 64 to 8192 kbps and for H.264-2 is from 64 to 2048 kbps.

Display Compression Information

Users can also decide whether to display compression information on the Home page.

CBR Mode Setting

The CBR (Constant Bit Rate) mode could be the preferred bit rate mode if the bandwidth available is limited. It is important to take account of image quality while choosing to use CBR mode.

Click on <Save> to confirm the setting.

7.3.3 Video OCX Protocol

The Video OCX Protocol setting can be found under this path: **Streaming> Video OCX Protocol**.

In the Video OCX protocol setting page, users can select RTP over UDP, RTP over TCP, RTSP over HTTP or MJPEG over HTTP, for streaming video over the network. In the case of multicast networking, users can select the Multicast mode.

Video OCX protocol setting options include:

- **RTP over UDP / RTP over RTSP(TCP) / RTSP over HTTP / MJPEG over HTTP**
- **Multicast Mode**
Enter all required data, including <Multicast IP Address>, <H.264 Video Port>, <MJPEG Video Port>, <Audio Port> and <TTL> into each blank.

Click on <Save> to confirm the setting.

7.3.4 Video Frame Rate

The Video Frame Rate setting can be found under this path: **Streaming> Video Frame Rate**.

Video frame rate is for setting the frames per second (fps) if necessary.

MJPEG/ H.264-1/ H.264-2 Frame Rate

The default setting of MJPEG/H.264-1/H.264-2 Frame Rate is 30 fps; the setting range is from 1 to 30.

Click on <Save> to confirm the setting.



NOTE: Lower frame rate will decrease video smoothness.

7.3.5 Video Mask

The Video Mask setting can be found under this path: **Streaming> Video Mask**.

Active Mask Function

- **Add a Mask**

Check a Video Mask checkbox, and a red frame will come out in the Live Video pane at the right side. Use the mouse to drag and drop to adjust the mask's size and place it on the target zone.



NOTE: It is suggested to set the Video Mask twice bigger than the object.

- **Cancel a Mask**

Uncheck the checkbox of the Video Mask meant to be deleted, and the selected mask will disappear from the Live Video pane instantly.

Mask Setting

- **Mask color**

The selections of Mask color include red, black, white, yellow, green, blue, cyan, and magenta. Click on <Save> to confirm the setting.

7.3.6 Audio (Audio Mode and Bit Rate Settings)

The Audio Mode setting can be found under this path: **Streaming> Audio**. In the Audio page, the Administrator can select one transmission mode and audio bit rate.

Transmission Mode

- **Full-duplex (Talk and Listen simultaneously)**
In the Full-duplex mode, the local and remote sites can communicate with each other simultaneously, i.e. both sites can speak and be heard at the same time.
- **Half-duplex (Talk or Listen, not at the same time)**
In the Half-duplex mode, the local/remote site can only talk or listen to the other site at a time.
- **Simplex (Talk only)**
In the Talk only Simplex mode, the local/remote site can only talk to the other site.



NOTE: This function is not available for Compact Fixed Dome.

- **Simplex (Listen only)**
In the Listen only Simplex mode, the local/remote site can only listen to the other site.
- **Disable**
Select the item to turn off the audio transmission function.

Server Gain Setting

Set the audio input/output gain levels for sound amplification. The audio gain values are adjustable from 1 to 6. The sound will be turned off if the audio gain is set to "Mute".

Bit Rate

Selectable audio transmission bit rate include 16 kbps (G.726), 24 kbps (G.726), 32 kbps (G.726), 40 kbps (G.726), uLAW (G.711) and ALAW (G.711). Both uLAW and ALAW signify 64 kbps but in different compression formats. Higher bit rate

will let higher audio quality and require bigger bandwidth. Click on <Save> to confirm the setting.

7.4 Camera

Under the tab <Camera>, there are submenus including: <Exposure>, <White Balance>, <Picture Adjustment>, <Backlight>, <Digital Zoom>, <IR Function>, <WDR Function>, <Noise Reduction>, and <TV System>.

7.4.1 Exposure Setting

The Exposure Setting can be found under this path: **Camera> Exposure**.

The exposure is the amount of light received by the image sensor and is determined by the width of lens diaphragm opening, the amount of exposure by the sensor (shutter speed) and other exposure parameters. With this item, users can define how the Auto Exposure function works.

Each exposure mode is specified as follows:

- **Auto Iris (Fixed Focal Lens Excluded)**

In this mode, the exposure gives priority to the auto iris. The minimum shutter speed can be set from 1 (1/1.5) to 1/30 (1/25) sec. AGC (Auto Gain Control) will function automatically according to the light conditions of the subject.



NOTE: This function is not available for Fixed Focal Lens Models.

- **Auto Shutter Mode**

This function is to control the shutter speed and adjust the iris automatically according to the light intensity. It is also effective if a fixed iris lens is being used. The minimum shutter speed range is configurable from 1 (1/1.5) to 1/500 (1/425) sec.

- **Shutter Priority Mode**

This function is to set the shutter speed at a specified speed. The range is configurable from 1/30 (1/25) to 1/500 (1/425) sec.

Manual Mode

- **Fixed Shutter Mode**

In this mode, fixed shutter speed could be selected from the dropdown menu. The shutter speed range is from 1/10000 to 1 (1/1.5) sec. with 19 (18) options. Users could select suitable shutter speed according to the environmental illumination.

7.4.2 White Balance Setting

The White Balance Setting can be found under this path: **Camera> White Balance**.

A camera needs to find reference color temperature, which is a way of measuring the quality of a light source, for calculating all the other colors. The unit for measuring this ratio is in degree Kelvin (K). Users can select one of the White Balance Control modes according to the operating environment. The following table shows the color temperature of some light sources for reference.

Light Sources	Color Temperature in K
Cloudy Sky	6,000 to 8,000
Noon Sun and Clear Sky	6,500
Household Lighting	2,500 to 3,000
75-watt Bulb	2,820
Candle Flame	1,200 to 1,500

AWB (Auto White Balance)

The Auto Balance White mode is suitable for environment with light source having color temperature in the range roughly from 2700 ~ 7800K.

ATW Mode (Auto Tracking White Balance)

With Auto Tracking White Balance function, the white balance in a scene will be automatically adjusted while temperature color is changing. The ATW Mode is suitable for environment with light source having color temperature in the range roughly from 2500 ~ 10000K.

Manual Mode

In this mode, users can change the White Balance value manually. Users can select a number between 0 ~127 of “Rgain/ Bgain” item to gain the red/ blue illuminant on the Live Video Pane.

Click on <√> to confirm the new setting.

7.4.3 Picture Adjustment

The Picture Adjustment can be found under this path: **Camera> Picture Adjustment.**

Brightness

Users can adjust the image's brightness by adjusting the item. Please select ranging from -12 to +13. To increase video brightness, select a bigger number. Click on <√> to confirm the new setting.

Sharpness

Increasing the sharpness level can make the image looked sharper; especially enhance the object's edge. Please select ranging from +0 to +15. Click on <√> to confirm the new setting.

Contrast

Camera image contrast level is adjustable; please select ranging from -6 to +19. Click on <√> to confirm the new setting.

Saturation

Camera image saturation level is adjustable; please select ranging from -6 to +19. Click on <√> to confirm the new setting.

Hue

Camera image hue level is adjustable; please select ranging from -12 to +13. Click on <√> to confirm the new setting.

7.4.4 Backlight

The Backlight Setting can be found under this path: **Camera> Backlight.**

The Backlight Compensation function prevents the center object from being too dark in surroundings where excessive light is behind the center object. Click on <√> to confirm the new setting.

7.4.5 Digital Zoom

The Digital Zoom Setting can be found under this path: **Camera> Digital Zoom**.

The camera's digital zoom is adjustable from x2 to x8. Click on <√> to confirm the new setting.

7.4.6 IR Function (Compact Fixed Dome Excluded)

The IR Function Setting can be found under this path: **Camera> IR Function**.

Auto/On/Off Mode

With the IR cut filter, the Camera can still catch clear image at night time or in low light conditions.

For the camera with the built-in IR LED module, there will be three additional IR function modes (Light Sensor/ Light On/ Light Off) as follows:

Light Sensor Mode

IR LED lights will be turned on/off depending on the light sensor.

Light On Mode

In this mode, IR LED lights will be always on.

Light Off Mode

In this mode, IR LED lights will be always off.

Smart Mode

The Smart Mode enhances the monochrome/night mode stability in the scenario that IR illumination is dominant. In this mode, when the external IR illuminator is turned on, the IR cut filter of the IP Camera will keep open (i.e. monochrome/night mode), preventing the camera from returning to the color/day mode when IR illumination is dominant.

Additionally, for the models with built-in IR LED module, the day/night IR switching mechanism will depend on the ambient light level instead of the light sensor (Light sensor mode) on the IR LED module.

Click on <√> to confirm the new setting.

7.4.7 WDR Function

The WDR Function Setting can be found under this path: **Camera> WDR Function**.

The Wide Dynamic Range (WDR) function is for solving high contrast or changing light issues so that enhances better video display. The WDR is adjustable from Low, Mid to Hi. Higher level of WDR represents wider dynamic range, so that the IP Camera can catch a greater scale of brightness. Click on <√> to confirm the new setting.

7.4.8 Noise Reduction

The Noise Reduction Setting can be found under this path: **Camera> Noise Reduction**.

The IP Camera provides multiple <Noise Reduction> options for delivering optimized image quality especially in extra low-light conditions.

Different level options for 3D Noise Reduction (3DNR) include Low, Mid and High. Higher level of 3DNR generates relatively enhanced noise reduction.

The proprietary Smart Picture Quality (SPQ) video processing method could drastically minimize motion blur and reduce noise especially in low-light environment. The combination of SPQ and 3DNR at different level further yields exceptional video performance in various conditions.

The Noise Reduction function is configurable with the following options: 3DNR Low, 3DNR Mid, 3DNR Hi, SPQ, SPQ + 3DNR Low, SPQ + 3DNR Mid, to SPQ + 3DNR Hi.

Click on <√> to confirm the new setting.

7.4.9 TV System Setting

The TV System Setting can be found under this path: **Camera> TV System**.

Select the video format that matches the present TV system. Click on <√> to confirm the new setting.

7.5 Pan Tilt

Under the tab <Pan Tilt>, there are submenus including: <Preset>, <Sequence>, and <Pan/ Tilt Control>.



NOTE: Pan Tilt function is only available for 10x/ 18x Zoom AF IP Camera and Box Camera (DC12V/ AC24V/PoE Model).

With RS-485 support, the IP Camera is capable of working with a Pan Tilt Head for pan and tilt control. Before implementing pan/tilt control, please ensure the Pan & Tilt Head is correctly connected to the IP Camera's RS-485 port.

Pin Definition for IP Camera's RS-485 Port

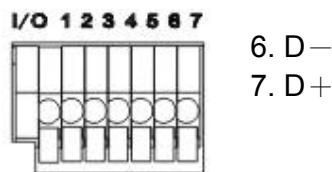

7.5.1 Preset

The Preset Setting can be found under this path: **Pan Tilt> Preset**.



NOTE: Before setting this function, users must enable the Pan/ Tilt Control first. Please refer to [Pan/ Tilt Control](#) for more details.

There are up to 127 preset points that can be set in the Preset setup page. Please follow the steps below to set and run preset points.

Preset Points Setup

- Step 1.** Move the camera to the desired position by moving the mouse cursor onto the screen, one left click on mouse, and then dragging the red arrow to pan/tilt. Users may adjust the zoom position as well.
- Step 2.** Once a Preset Point is defined, please assign a number (between 1 and 127) and enter it into the input field.

Step 3. Click on the <√> button to save the defined preset point.

Preset Run

Type the Preset Point number into the Preset field, click on the  button, and the camera will turn to the appointed point.

7.5.2 Sequence

The Sequence Setting can be found under this path: **Pan Tilt> Sequence**.

The Sequence function supports totally eight Sequence Lines; each Sequence Line consists of up to 64 Preset Points. Please refer to the instructions below to program a Sequence Line.



NOTE: Before setting this function, users must pre-define at least two Preset Points.

Sequence Setting

- **Sequence Line**

Please select the number of Sequence Line to be set from the drop-down list.

- **Sequential Preset Points Setting**

Please setup each Preset Point of the programmed Sequence Line in order, assigning a Preset Point from the “NO” list for the specified number of Preset Point and entering Dwell Time (0~255 sec.) into the corresponding fields.

- **Sequence Reset**

To reset the sequence setting of each line, please click on the <Reset> button in the right top corner of the setup page. And then click on the <Set> button on the left to refresh the page in order to enter the new settings.

When finishing the sequential Preset Points setting, please click on the button <Save> in the top of the Sequence setting menu.

Sequence Run

Select the specified Sequence Line from the drop-down list, click on the  button, and then the camera will start moving forward each scene sequentially as programmed.

To view the camera executing a Sequence Line in full screen mode, please move the cursor onto the live view pane, right-click and left-click to select “fullscreen”. Then users can view the camera navigation in full screen.

To stop running the Sequence Line, simply move the cursor to the live view pane and move the camera in any direction.

7.5.3 Pan/Tilt Control

The Pan/Tilt Control Setting can be found under this path: **Pan Tilt> Pan/Tilt Control**.

Users can activate the pan/ tilt function and select the RS-485 protocol which the Pan Tilt Head uses in the Pan/ Tilt Control page.

Pan/ Tilt Control

Users can enable or disable the Pan/ Tilt Control.

Click on <Save> to confirm the setting.

RS-485 Protocol Type

Protocol and Baud rate type options include:

- **DSCP (9600)**
- **PelcoD (2400)**
- **PelcoD (4800)**
- **PelcoD (9600)**
- **PelcoP (2400)**
- **PelcoP (4800)**
- **PelcoP (9600)**

Click on <Save> to confirm the setting

Move the camera to the desired position by moving the mouse cursor onto the screen, one left click on mouse, and then dragging the red arrow to pan/tilt.

7.6 Logout

Click on the tab <Logout> on the top of the page, and the login window will pop up. This enables log in with another user name.

Appendix A: Technical Specifications

Camera		2M	2M Real-time
Image Sensor		1/2.7" Progressive CMOS	
Effective Pixels		1920(H) x 1080(V)	
Minimum Illumination	Color	0.1 lux @ F1.5	
Shutter Speed		1~ 1/10000 sec.	
White Balance		Manual / AWB/ ATW	
Lens			
Fixed Lens		F 1.5 / f = 4.0 mm	
FOV		78°	
Operation			
Video Compression		H.264/ MJPEG	
Video Streaming		Simultaneous H.264 1080p (13/15 fps) + MJPEG 720p (25/30 fps)	Simultaneous H.264 1080p (25/30 fps) + MJPEG D1 (25/30 fps)
		Simultaneous H.264 1080p (13/15 fps) + H.264 720p (25/30 fps)	Simultaneous H.264 1080p (25/30 fps) + H.264 D1 (25/30 fps)
Resolution	H.264	Full HD 1080p/ SXGA/ HD720p/ XGA/ SVGA/ D1/ VGA/ CIF	
	MJPEG		
Image Setting	Brightness	Manual	
	Exposure	Auto/Manual	
	Sharpness	Manual	
	Contrast	Manual	
	White Balance	Auto/Manual	
	Saturation	Manual	
	Hue	Manual	
	Backlight Compensation	On/Off	
	Digital Zoom	Support	
	WDR	On/Off	
	3D Noise Reduction	On/Off	
	Motion detection	On/Off	
	Privacy Mask	On/Off	
	Privacy Mask Type	Color	
Tampering Alarm	On/Off		
Audio	One-way Audio*	Mic in	

	Compression	G.711/G.726
Event Notification		HTTP, FTP, SMTP
Multiple Languages		English, French, German, Italian, Korean, Simplified Chinese, Traditional Chinese, Russian,
Network		
Interface		10/100Mbps Ethernet (RJ-45)
Protocol		IPv4/ v6, TCP/IP, UDP, RTP, RTSP, HTTP, HTTPS, ICMP,FTP, SMTP, DHCP, PPPoE, UPnP, IGMP, SNMP, QoS, and ONVIF
Password Levels		User and Administrator
Security		HTTPS, IP Filter, IEEE 802.1X
Internet Browser		Internet Explorer (6.0+), Chrome, Firefox, Safari
User Account		20
Mechanical		
Lens Mounting		M12 Board Lens
Connectors	Ethernet	RJ-45
	Micro SD*	Micro SDHC 32GB support
General		
Operating Temperature		-10°C ~ 50°C (14°F~122°F)
		Humidity: 10% to 90%, no condensation
Power Source		PoE
Power Consumption		3.5 W
Weatherproof	Rugged Camera	IP66
Regulatory		CE, FCC, RoHS Compliant
Dimension		∅ 110.2 x 47.7 mm (∅ 4.3 x 1.9 in.)
Weight		180g (0.40 lb)

(*) Optional

Appendix B: Delete the Existing DC Viewer

For users who have installed the DC Viewer in the PC previously, please first remove the existing DC Viewer from the PC before accessing to the IP Camera.

Deleting the DC Viewer

In the Windows <Start Menu>, activate <Control Panel>, and then double click on <Add or Remove Programs>. In the <Currently installed programs> list, select <DCViewer> and click on the button <Remove> to uninstall the existing DC Viewer.

Deleting Temporary Internet Files

To improve browser performance, it is suggested to clean up the all the files in the Temporary Internet Files.

The procedure is as follows:

Step 1: Click on the <Tools> tab on the menu bar and select <Internet Options>.

Step 2: Click on the <Delete> button under <Browsing history> section. Then click on the <Delete Files> button under the <Temporary Internet files> section.

Step 3: A confirmation window will pop up. Click on <Yes> to start deleting the files.

Appendix C: Setup Internet Security

If ActiveX control installation is blocked, please either set Internet security level to default or change ActiveX controls and plug-ins settings.

Internet Security Level: Default

Step 1: Start the Internet Explorer (IE).

Step 2: Click on the <Tools> tab on the menu bar and select <Internet Options>.

Step 3: Click on the <Security> tab, and select <Internet> zone.

Step 4: Down the page, click on the <Default Level> button and click on <OK> to confirm the setting. Close the browser window, and restart a new one later to access the IP Camera.

ActiveX Controls and Plug-ins Settings

Step 1: Repeat **Steps 1~3** of the previous section above.

Step 2: Down the page, click on the <Custom Level> button to change ActiveX controls and plug-ins settings. The Security Settings window will pop up.

Step 3: Under <ActiveX controls and plug-ins>, set **ALL** items (as listed below) to <Enable> or <Prompt>. Please note that the items vary by IE version.

ActiveX controls and plug-ins settings:

1. Allow previously unused ActiveX controls to run without prompt.
2. Allow Scriptlets.
3. Automatic prompting for ActiveX controls.
4. Binary and script behaviors.
5. Display video and animation on a webpage that does not use external media player.
6. Download signed ActiveX controls.
7. Download unsigned ActiveX controls.
8. Initialize and script ActiveX controls not marked as safe for scripting.
9. Run ActiveX controls and plug-ins.
10. Script ActiveX controls marked safe for scripting.

Step 4: Click on <OK> to accept the settings and close the Security Settings window.

Step 5: Click on <OK> to close the Internet Options screen.

Step 6: Close the browser window, and restart a new one later to access the IP Camera.

Appendix E: Install UPnP Components

Please follow the instructions below to install UPnP components on Windows Vista/ Windows XP/ Windows 7.

Step 1: In the Windows, go to <Start Menu>, click on <Control Panel>, and then double click on <Add or Remove Programs>.

Step 2: Click on <Add/ Remove Windows Components> in the Add or Remove Programs page.

Step 3: Select <Networking Services> from the Components list in the Windows Components Wizard window, and then click on <Details>.

Step 4: Select <UPnP User Interface> in the Networking Services' subcomponents list and then click on <OK>.

Step 5: Click on <Next> in the Windows Components Wizard window.

Step 6: Click on <Finish> to complete installation.

Razberi Technologies
1628 Valwood Pkwy #148
Carrollton, TX 75006
P.469-828-3380
www.razberi.net