

Compact Disc Player

Operating Instructions



***CDP-CX270
CDP-CX90ES***

WARNING

To prevent fire or shock hazard, do not expose the unit to rain or moisture.

To avoid electrical shock, do not open the cabinet. Refer servicing to qualified personnel only.



This symbol is intended to alert the user to the presence of uninsulated "dangerous voltage" within the product's enclosure that may be of sufficient magnitude to constitute a risk of electric shock to persons.



This symbol is intended to alert the user to the presence of important operating and maintenance (servicing) instructions in the literature accompanying the appliance.

INFORMATION

This equipment has been tested and found to comply with the limits for a Class B digital device, pursuant to Part 15 of the FCC Rules. These limits are designed to provide reasonable protection against harmful interference in a residential installation. This equipment generates, uses, and can radiate radio frequency energy and, if not installed and used in accordance with the instructions, may cause harmful interference to radio communications. However, there is no guarantee that interference will not occur in a particular installation. If this equipment does cause harmful interference to radio or television reception, which can be determined by turning the equipment off and on, the user is encouraged to try to correct the interference by one or more of the following measures:

- Reorient or relocate the receiving antenna.
- Increase the separation between the equipment and receiver.
- Connect the equipment into an outlet on a circuit different from that to which the receiver is connected.
- Consult the dealer or an experienced radio/TV technician for help.

CAUTION

You are cautioned that any changes or modification not expressly approved in this manual could void your authority to operate this equipment.

Owner's Record

The model and serial numbers are located at the rear of the unit. Record the serial number in the space provided below. Refer to them whenever you call upon your Sony dealer regarding this product.

Model No. _____
Serial No. _____

This equipment is intended for home entertainment purposes only. The warranty shall be invalidated if used in commercial environments, such as by disc jockeys, etc., even within the Warranty Period.

Welcome!

Thank you for purchasing the Sony Compact Disc Player. Before operating the unit, please read this manual thoroughly and retain it for future reference.

About This Manual

The instructions in this manual are for models CDP-CX270 and CDP-CX90ES.

Conventions

- Instructions in this manual describe the controls on the player. You can also use the controls on the remote if they have the same or similar names as those on the player.
- The following icons are used in this manual:



Indicates that you can do the task using the remote.



Indicates hints and tips for making the task easier.

TABLE OF CONTENTS

Getting Started

Unpacking	4
Hooking Up the System	4
Controlling Another CD Player (Player Control)	6
Inserting CDs	8

Playing a CD	10
--------------------	----

Playing CDs

Using the Front Panel Display	12
Using the On-Screen Display	13
Locating a Specific Disc	13
Sorting Out Discs in Three Ways (Sort)	14
Specifying the Next Disc to Play	16
Locating a Specific Track or a Point in a Track	16
Playing Repeatedly	17
Playing in Random Order (Shuffle Play)	18
Creating Your Own Program (Program Play)	18
Playing Alternately (X-Fade Play)	21
Playing Using a Timer	22
Using a Sony Receiver With the On-Screen Display Control Function	22

Storing Information About CDs (Custom Files)

What You Can Do With the Custom Files	23
Labeling Discs (Disc Memo)	23
Grouping Discs (Group File)	26
Storing Custom File Information Using a Keyboard	28
Storing Specific Tracks (Delete File)	28
Storing Your Favorite Tracks (Hit List)	29

Additional Information

Precautions	30
Notes on CDs	30
Troubleshooting	31
Specifications	31

Index	Back cover
-------------	------------

Unpacking

Check that you received the following items:

- Audio cord (1)
- Video cord (1)
- Remote commander (remote) (1)
- Sony SUM-3 (NS) batteries (2)
- CD booklet holders (2) and label (1)

💡 How to use the CD booklet holder

The CD booklet holder helps you locate the discs easily. After you have inserted discs into the player, you can put the CD booklet (which comes with a CD) into the supplied holder. Put two CD booklets facing back to back into a pocket. Stick the number label on each pocket, matching the number of the disc slot where you have inserted the disc. You can put up to 200 CD booklets into the holders.

Inserting batteries into the remote

You can control the player using the supplied remote. Insert two R6 (size AA) batteries by matching the + and - on the batteries. When using the remote, point it at the remote sensor  on the player.

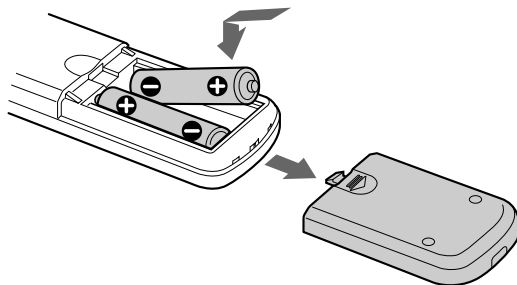

💡 When to replace batteries

With normal use, the batteries should last for about six months. When the remote no longer operates the player, replace all the batteries with new ones.

Notes

- Do not leave the remote near an extremely hot or humid place.
- Do not drop any foreign object into the remote casing, particularly when replacing the batteries.
- Do not expose the remote sensor to direct sunlight or lighting apparatuses. Doing so may cause a malfunction.
- If you do not use the remote for an extended period of time, remove the batteries to avoid possible damage from battery leakage and corrosion.

Hooking Up the System

Overview

This section describes how to hook up the CD player to a TV and an amplifier. Be sure to turn off the power of each component before making the connections.

When connecting to an amplifier with a video input jack

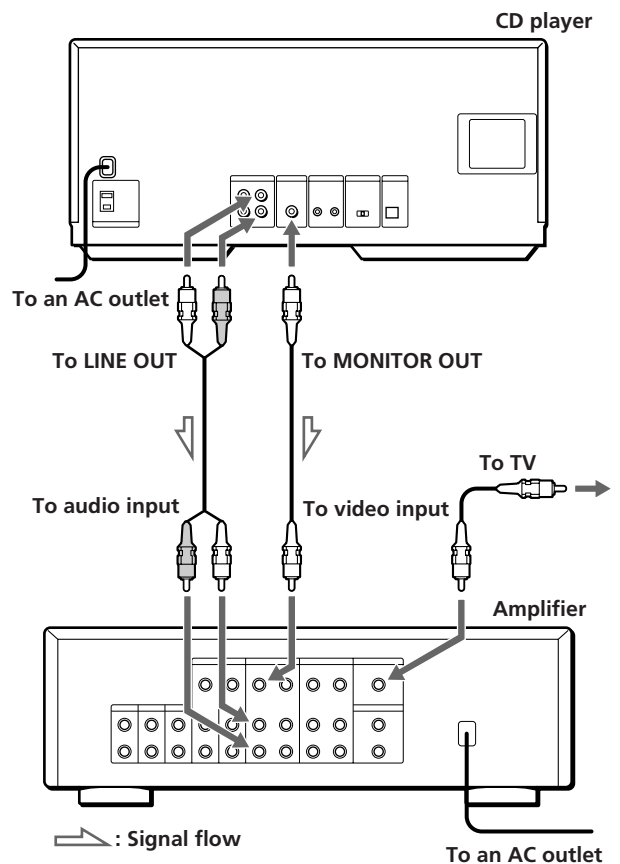

When connecting to an amplifier without a video input jack

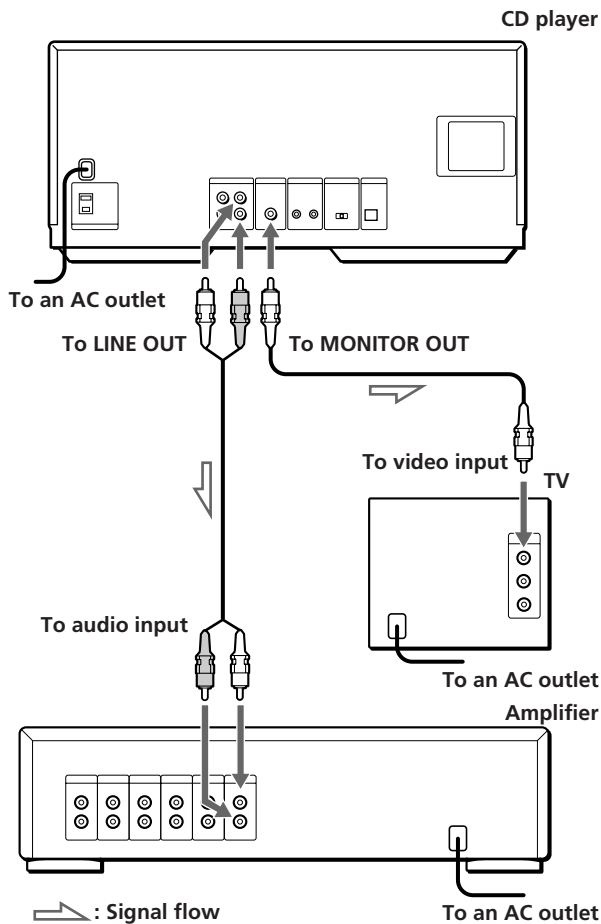

What cords will I need?

Audio cord (1) (supplied)

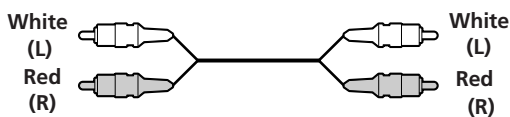

Video cord (1) (supplied)



Hookups

When connecting the cords, be sure to match the color-coded plugs to the appropriate jacks on the components: Yellow (video) to Yellow, Red (right) to Red and White (left) to White. Be sure to make connections firmly to avoid hum and noise.

When connecting to an amplifier with a video input jack

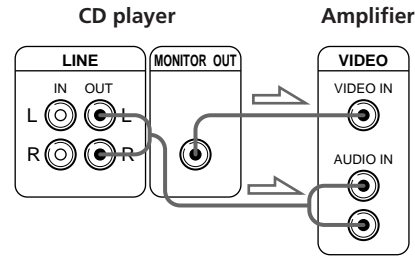

When connecting to an amplifier without a video input jack

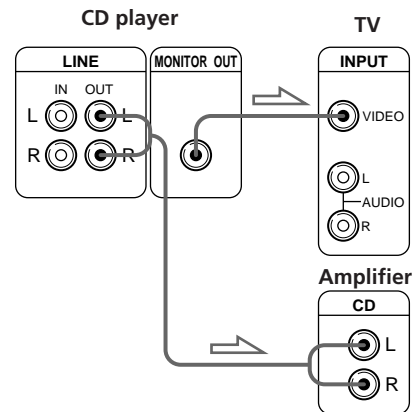

- **If you have a Sony receiver (amplifier) equipped with the CONTROL A1 jack**

Be sure to connect the player to the VIDEO 2 jacks on the receiver (amplifier). When making this connection, leave the COMMAND MODE of the player to CD2 which is set at the factory.

If you further connect the player and the receiver (amplifier) via the CONTROL A1 jacks with the CONTROL A1 cord (not supplied), you can use the Automatic Function Selection feature between these components. For details, refer to the supplementary "CONTROL-A1 Control System" instructions and the instructions supplied with the receiver (amplifier).

- **If you have a Sony receiver (amplifier) with the On-Screen Display Control function**

You can control the player using the on-screen display and the remote supplied with the receiver.

For details, see page 22.

Getting Started

- If you have a digital component such as a digital amplifier, D/A converter, DAT or MD

Connect the component via the DIGITAL OUT (OPTICAL) connector using an optical cable (not supplied). Take off the cap and plug in the optical cable.

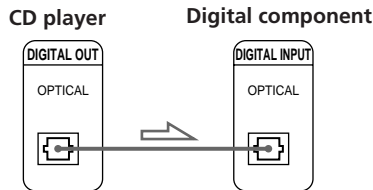
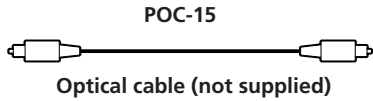

Note

When you connect via the DIGITAL OUT (OPTICAL) connector, noise may occur when you play CD software other than music, such as a CD-ROM.

💡 When using another Sony CD player together with this player

You can make the supplied remote effective only for this player.

- When using a player equipped with the COMMAND MODE selector:
Leave the COMMAND MODE selector of this player to CD2 which is set at the factory and that of another player to CD1 or CD3. Then set the CD1/2/3 switch on the remote supplied for each player accordingly.
- When using a player not equipped with the COMMAND MODE selector:
The command mode of the player without the COMMAND MODE selector is set to CD1. Leave the COMMAND MODE selector of this player and the CD1/2/3 switch on the remote to CD2.

Connecting the AC power cord

Connect the AC power cord to a wall outlet.

Note on placement

Be sure to place the player on a horizontal surface. If the player is slanted, it may cause a malfunction or damage the player.

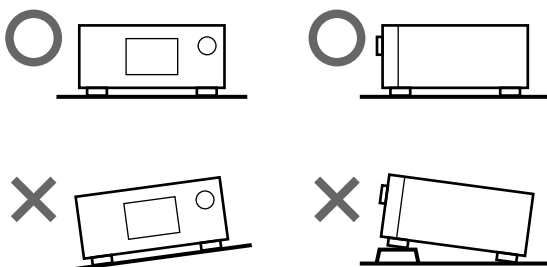

Controlling Another CD Player (Player Control)

If you have a Sony CD player equipped with the CONTROL A1 jack, you can control that player as the second player with this unit. After connecting the second player, you can select either player by simply pressing the PLAYER SELECT button and enjoy playing the discs inserted in both players. Be sure to turn off the power of each player before making this connection.

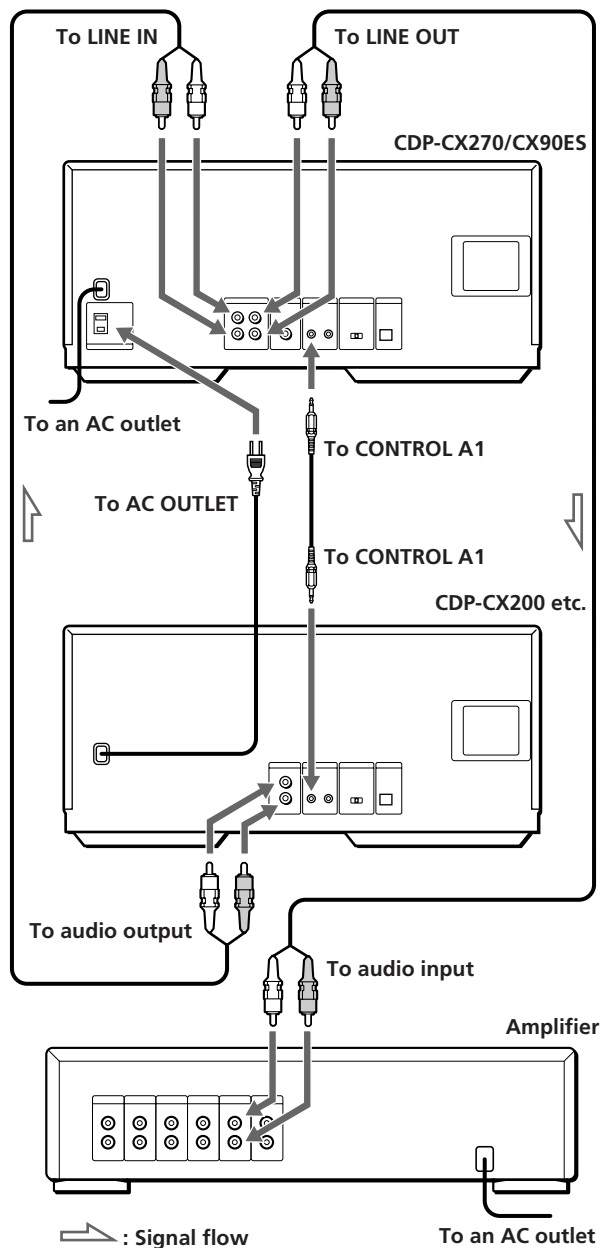

What cords will I need?

- Audio cord (1) (supplied with the player to be connected)
- CONTROL A1 cord (1) (not supplied)

1 Connect the players with the audio cord (see also "Hookups" on page 5).

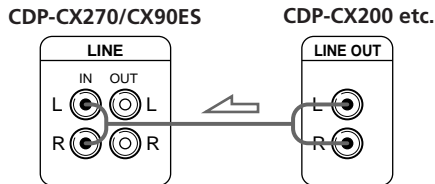

2 Connect the players with the CONTROL A1 cord.

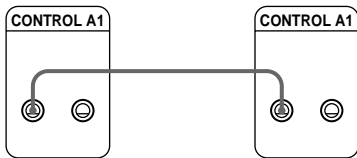

For details on this connection, refer to the supplementary "CONTROL-A1 Control System" instructions.

3 Set the COMMAND MODE selector of each player.
Leave the COMMAND MODE of this player set to CD2, and set that of the second player to CD3

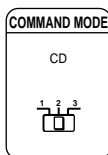

4 Connect the AC power cord of the second player to AC OUTLET on the rear of this player.

When you turn on both players and this player detects the second player, "REMOTE" appears in the second player's display.

You cannot operate the second player using the controls on the second player while "REMOTE" appears in the second player's display.

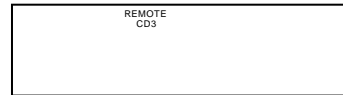

While the second player is selected, "2nd PLAYER" appears in this player's front panel display.

Note

Do not connect a player other than a Sony CD player equipped with the CONTROL A1 jacks to the LINE IN jacks of this player. If you do, a loud noise may occur and damage the speakers.

💡 You can connect the CD player CDP-CX153 as the second player

Connect the CONTROL A1 jack of this player and the CONTROL A jack of the CDP-CX153. For details, refer to the supplementary "CONTROL-A1 Control System" instructions.

Note that you cannot use the X-Fade Play function (see page 21) when connecting the CDP-CX153.

Inserting CDs

You can insert up to 200 discs into this player.

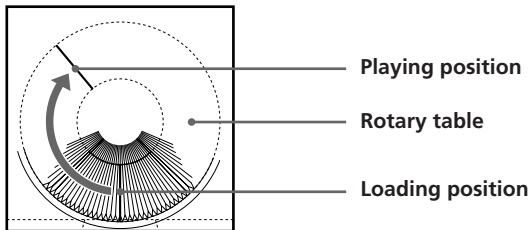
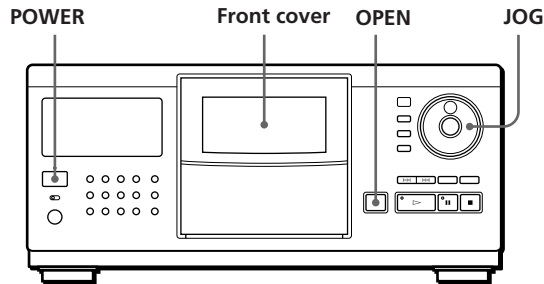

- 1 Press POWER to turn on the player.
- 2 Press OPEN.

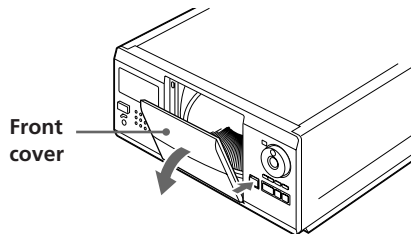

- 3 Turn the JOG dial until you find the disc slot where you want to insert a disc, while checking the disc number (written beside every five slots and also indicated in the display).

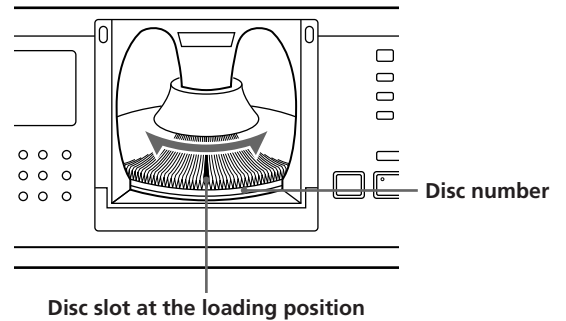

The disc number at the loading position appears in the front panel display.* If you have labeled the disc with disc title (see page 23), the disc title appears instead of the disc number. As you turn the JOG dial, the disc number or the disc title changes.

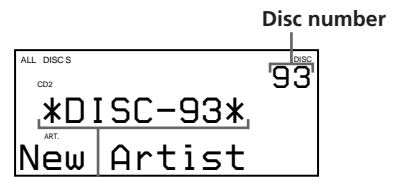

Disc number or disc title

* If you have already inserted discs, the disc number at the playing position appears. When you turn the JOG dial, the displayed disc number changes to the one at the loading position.

- 4 Insert a disc with the label side facing right.

Notes

- Make sure you have inserted the disc into each slot at a right angle to the rotary table. If the disc is not put in straight, it may damage the player or the disc.
- Make sure the rotary table comes to a complete stop before inserting or removing discs.

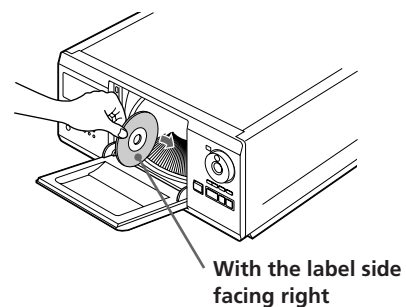

After inserting the disc, you can replace the disc number with the original disc title (see “Labeling Discs” on page 23) to locate it easily when you start playing.



- 5 Repeat Steps 3 and 4 to insert more discs.
- 6 Close the front cover by pushing up the cover until it clicks.

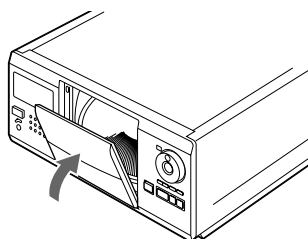

The rotary table turns and the disc slot at the loading position is set to the playing position. Always keep the front cover closed except when you insert or remove discs.

The supplied CD booklet holders help you locate a disc

You can store up to 200 CD booklets. Insert a booklet and stick the number label on the film of a pocket and the booklet so that you can locate the disc easily.

Notes

- When you insert an 8 cm (3-inch) CD, be sure to attach a Sony CSA-8 adaptor (not supplied) to the disc.
Do not insert an empty 8 cm (3-inch) CD adaptor (CSA-8). It may damage the player.
- **Do not attach anything such as seals or sleeves to discs. It may damage the player or the disc.**
- If you drop a disc into the player and the disc won't go into the slot correctly, consult your nearest Sony dealer.
- When transporting the player, remove all discs from the player.

Removing CDs

After following Steps 1 through 3 of “Inserting CDs” on page 8, remove the discs. Then close the front cover.

Note

The disc being played does not come to the loading position if you open the front cover during playback. (The disc number flashes in the display.)

If you want to remove the disc being played, press ENTER in the center of the JOG dial after opening the front cover. The disc comes to the loading position. Remove the disc after the rotary table comes to a complete stop.

Playing a CD

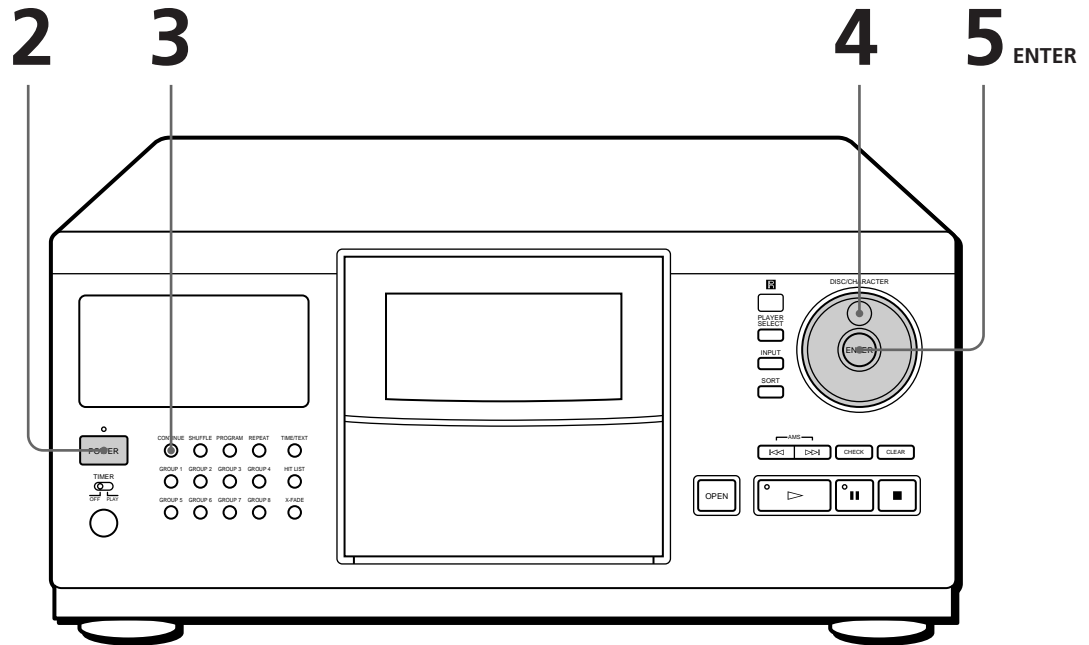

- See pages 4–6 for hookup information.
- Make sure you have inserted the discs correctly as indicated on page 8.
- You can play all tracks on a disc or on all discs in the original order (Continuous Play). When connected to the second player, you can play the discs in this player and the ones in the second player consecutively (see page 6).

You can turn on the player by pressing the POWER switch on the remote

- 1 Turn on the amplifier and select the CD player position.
- 2 Press POWER to turn on the player.
- 3 Press CONTINUE to select ALL DISCS or 1 DISC Continuous Play mode.
Each time you press CONTINUE, “ALL DISCS” or “1 DISC” appears in the front panel display.

When you select	The player plays
ALL DISCS	All discs in the player consecutively according to the selected sorting method (see “Sorting Out Discs in Three Ways” on page 14). Empty disc slots are skipped.
1 DISC	Only one disc you have selected

- 4 Turn the JOG dial until the disc number or the disc title (see “Labeling Discs” on page 23) you want appears in the front panel display to select the first disc (ALL DISCS) or the disc you want (1 DISC).

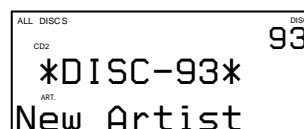



- 5** Press ENTER to start playing.
 The selected disc is set to the playing position, and the player plays all the discs from the selected one (ALL DISCS) or all the tracks once (1 DISC).
 Adjust the volume on the amplifier.

💡 When you turn off the player
 The player remembers the last playing disc and the play mode [Continuous, Shuffle (see page 18) or Program (see page 18)]. When you turn on the player again, therefore, the player is ready to play the same disc in the same play mode.

To stop playback

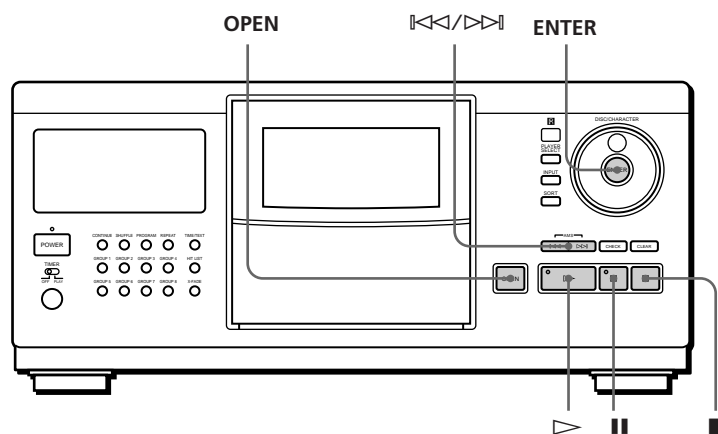
Press ■.



To	Press
Pause	
Resume playing after pause	or ▷
Go to the next disc 	DISC SKIP + once. Hold down the button to skip discs.
Go back to the preceding disc 	DISC SKIP - once. Hold down the button to skip discs.
Go to the next track	▷▷
Go back to the preceding track	◁◁
Stop playing and remove the disc	OPEN and then ENTER. The disc comes to the loading position.

Using the Front Panel Display

You can check information about the disc using the front panel display.

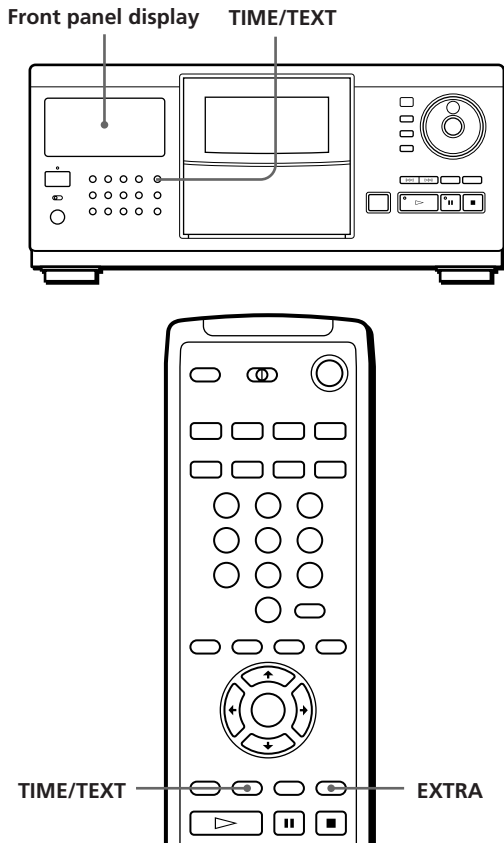

Display information before you start playing

The front panel display shows the current disc title and artist name. If you have not labeled the disc, the disc number and "New Artist" appear instead of the Disc Memo information (see "Labeling Discs" on page 23). When you press the TIME/TEXT button, you can check the total number of tracks and total playing time of the disc.

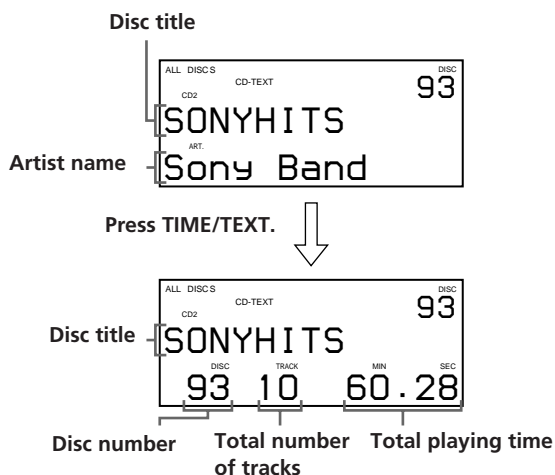

Display information while playing a disc

Each time you press the TIME/TEXT button, the front panel display shows the current disc information as shown below.

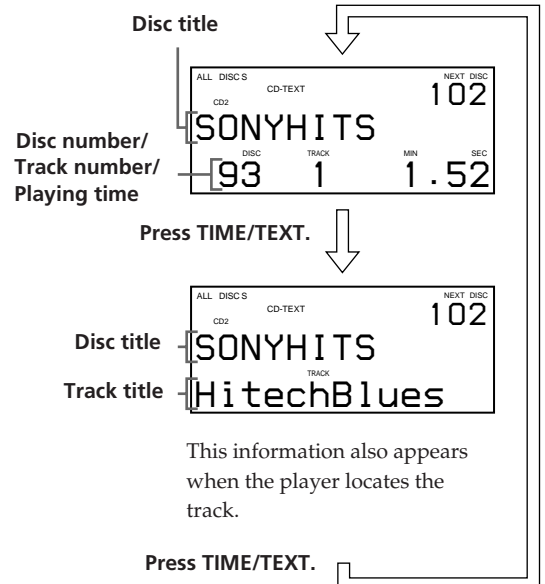

If you have not labeled the track (see "Labeling each track" on page 24), the front panel display information does not change when you press the TIME/TEXT button.

If you have CD-TEXT discs

CD-TEXT discs have information, such as the disc titles or artist names, memorized in a blank space on the discs where there is no information on normal discs. The CD-TEXT information (disc title, artist name and track title) will be stored as the Disc Memo automatically, so you can check that information in the same way as shown above.

To play disc highlights

Some CD-TEXT discs have a feature to play only the highlights of the discs.

Press EXTRA in the stop mode. The player starts playing the disc highlights in Continuous Play mode. The indicator on the ▷ button flashes while playing disc highlights.

If you press the EXTRA button while selecting a disc without this feature, "NO HIGHLIGHT" appears in the front panel display.

- You can cancel playing disc highlights by pressing the ▷ or ◀▶ buttons on the remote.
- You can play the previous or next highlight on the disc by pressing the ◀◀/▶▶ buttons (AMS, see page 16).
- You can repeat disc highlights (see page 17).

Press REPEAT. The player repeats all the highlights on the disc. During Repeat 1 mode, the player repeats only the current highlight.

Using the On-Screen Display

If you connect the player to your TV as indicated on pages 4 and 5, you can control the player while checking information with the on-screen display on the TV screen.

After connecting the player and TV, select the video input on the TV. If you have a Sony TV, you can select the video input by pressing the TV/VIDEO button on the supplied remote.

Display information while playing a disc

The on-screen display shows the current disc information stored in the Custom Files (see page 23) and playing time of the track.

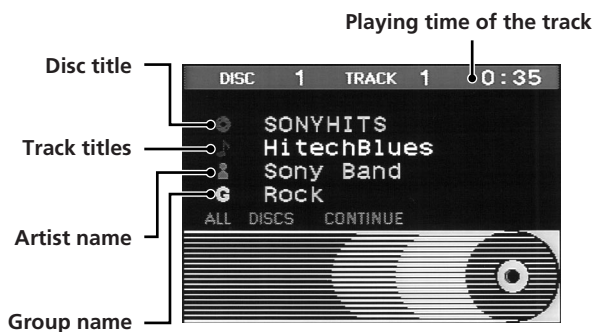

Display information while controlling the player

The on-screen display shows information useful for each operation.



The following icons are used in the on-screen display.

When the on-screen display shows	It means
↑/↓/←/→	You can select the items using the ↑/↓/←/→ buttons on the remote
[H]	The track is stored in the Hit List (see page 29)
[T]	The disc is CD-TEXT disc
②	The disc is inserted in the second player

You can adjust the on-screen display position on the TV screen

While the front cover is open, press TIME/TEXT then press ↑/↓/←/→ on the remote to adjust the position.

Locating a Specific Disc

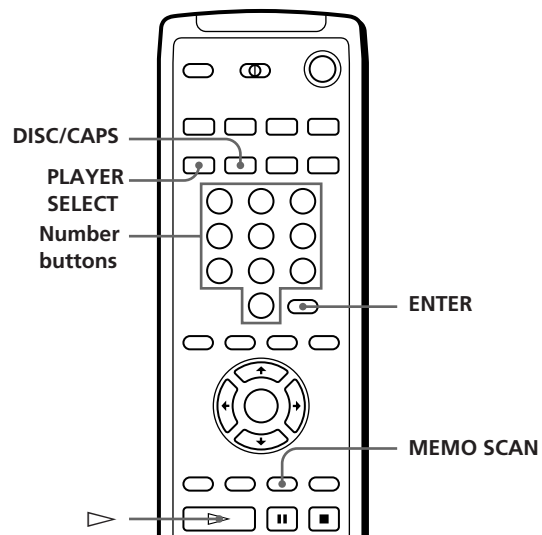
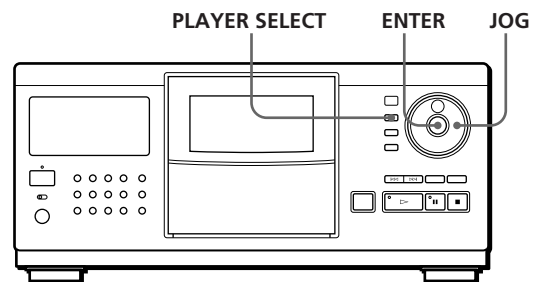

Selecting a disc on the player

Turn the JOG dial until the disc number or disc title (see page 23) you want appears in the front panel display. Press ENTER to start play.

Selecting a disc directly using the remote

- 1 Press DISC/CAPS.
- 2 Press the number button of the disc.
Example: To enter number 35
Press 3, then 5.
To enter number 100
Press 1, then 0 twice.
- 3 Press ENTER to start play.

Selecting a disc when connected to the second player

- 1 Press **PLAYER SELECT** to select the player in which the disc you want is inserted.
When you select the second player, "2nd PLAYER" appears in the front panel display.
- 2 Select the disc you want following the procedure in "Selecting a disc on the player" or "Selecting a disc directly using the remote."

Locating a disc by scanning each disc title (Memo Scan) 

You can locate a disc you want to play quickly by scanning the disc titles (see page 23) in the front panel display and start playing.
Note that you cannot use this function in ALL DISCS Shuffle Play mode.

- 1 Press **MEMO SCAN**.
"MEMO SCAN" appears and the disc titles scroll in the front panel display.
To cancel Memo Scan
Press **MEMO SCAN** again.
- 2 Press **▷** when the disc title of the disc you want to play appears.
The disc is set to the playing position, and the player starts playing.
In Program Play mode, the disc will be added to the end of the program if you press the **ENTER** button instead of the **▷** button.

Note
If "NO ENTRY" appears in the front panel display, no disc has been labeled with disc titles. Try the Memo Scan function again after labeling the discs with disc titles (see page 23).

Sorting Out Discs in Three Ways (Sort)

When locating discs, you can select three sorting methods, by disc number, disc title and artist name.

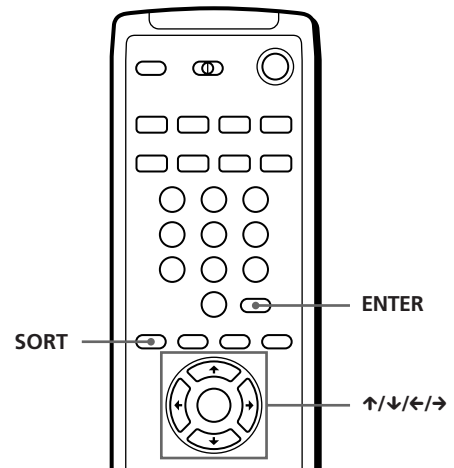
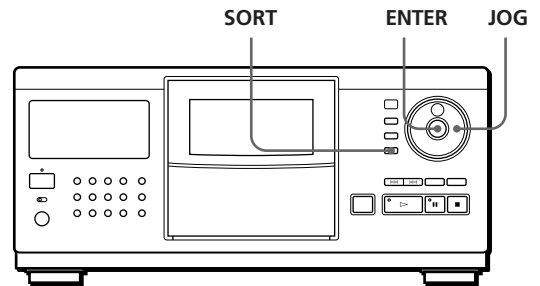

Each time you press the **SORT** button, the sorting method changes as shown below.

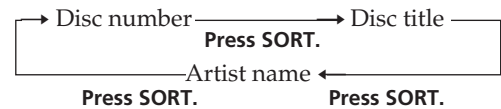

When you sort by	The display shows the discs in
Disc number	Numerical order of the disc numbers
Disc title*	Alphabetical order of the disc titles
Artist name*	Alphabetical order of the artist names

* Label discs to sort them by disc titles and artist names (see "Labeling Discs" on page 23).

When locating a disc by disc number

- 1 Press SORT repeatedly to select the sorting method.

Front panel display

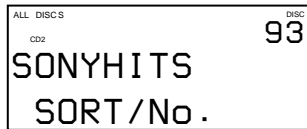

On-screen display

The on-screen display shows disc titles from disc number 91.

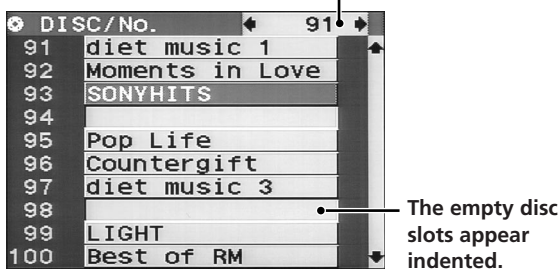

- 2 Turn the JOG dial (when using the remote, press \uparrow/\downarrow repeatedly) to select the disc you want. When using the remote, you can skip every 10 discs by pressing the \leftarrow/\rightarrow buttons.
- 3 Press ENTER to start playing the disc. The disc number being played is highlighted in the on-screen display.

When locating a disc by disc title

You can search a disc title by specifying the first character of the disc title. When you specify a character, the disc titles starting with the character appear.

- 1 Press SORT repeatedly to select the sorting method.

Front panel display



On-screen display

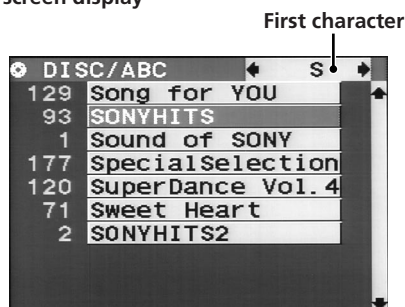

- 2 Press \leftarrow/\rightarrow on the remote repeatedly to select the first character of the disc title you want.

Front panel display



Each time you press the \leftarrow/\rightarrow buttons, you can select alphabets and then numbers. The characters which have not been used as the first character of disc titles will be skipped and the next one will appear.

Notes

- When searching disc titles, blanks before the first character in the disc title are ignored.
- When searching disc titles, upper and lower case characters cannot be differentiated.

- 3 Turn the JOG dial (when using the remote, press \uparrow/\downarrow repeatedly) to select the disc you want.
- 4 Press ENTER to start playing the disc.

When locating a disc by artist name

You can locate a disc by artist name. When you specify an artist name, the disc titles of the artist appear.

- 1 Press SORT repeatedly to select the sorting method.

Front panel display



On-screen display

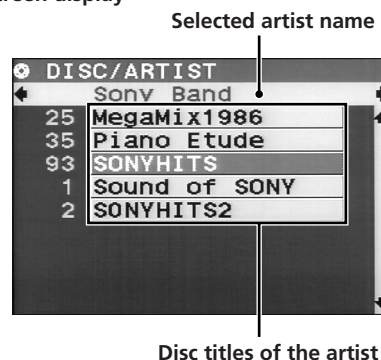

(Continued)

- 2 Press ←/→ on the remote repeatedly to select the artist name.
- 3 Turn the JOG dial (when using the remote, press ↑/↓ repeatedly) to select the disc you want.
- 4 Press ENTER to start playing the disc.

Specifying the Next Disc to Play

You can specify the next disc to play while playing a disc in Continuous or 1 DISC Shuffle Play mode.

While playing a disc, turn the JOG dial until the disc number or disc title (see page 23) you want appears in the front panel display.

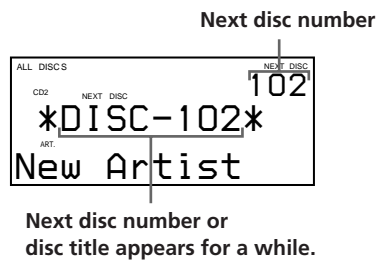

After the current disc is played, the next disc you have specified starts playing.

If you want to skip to the next disc right away, press ENTER while playing the current disc.



To cancel the disc you have specified

Press CONTINUE twice.

Locating a Specific Track or a Point in a Track

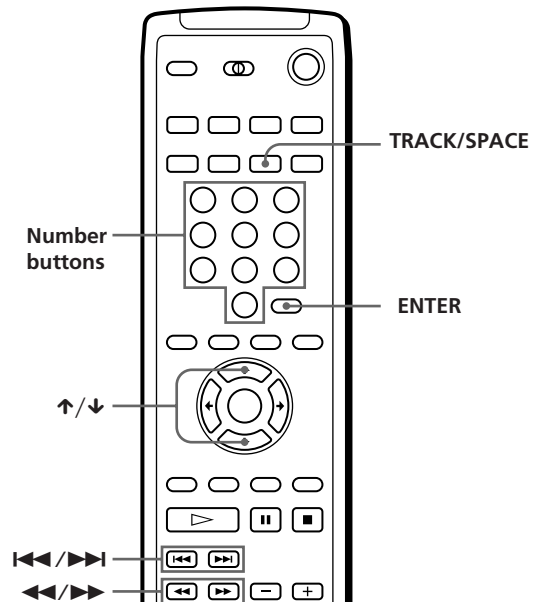
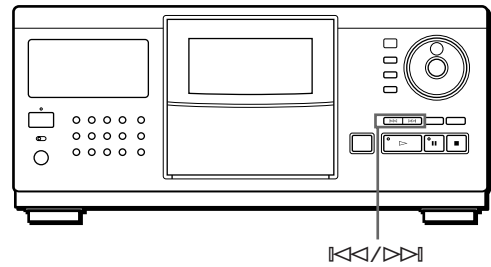
You can quickly locate any track while playing a disc using the ⏮/⏭ (AMS: Automatic Music Sensor) buttons or number buttons on the remote. You can also locate a specific point in a track while playing a disc.



To locate	Press
the next or succeeding tracks	▷▷ repeatedly until you find the track
the current or preceding tracks	◁◁ repeatedly until you find the track
a specific track directly 	TRACK/SPACE, the number button of the track, and then ENTER. When you locate a track with a number over 10, press the tens digit first, then the ones digit.
a point in a track while monitoring the sound 	▶▶ (forward) or ◀◀ (backward) and hold down until you find the point
a point in a track quickly by observing the display 	▶▶ (forward) or ◀◀ (backward) and hold down until you find the point during pause. You will not hear the sound during the operation.

Note

If "OVER" appears in the front panel display, the disc has reached the end while you were pressing the ▶▶ button. Press ◀◀ or |◁◁ to go back.

Checking the track titles using the on-screen display 

After labeling tracks (see page 24), you can select the track you want before you start playing while checking the track titles.

- 1 Press TRACK/SPACE.



The track titles stored in Delete File appear indented (see "Storing Specific Tracks" on page 28).

- 2 Press ↑/↓ to select the track you want.
- 3 Press ENTER to start playing the track. The track number being played is highlighted in the on-screen display.

Playing Repeatedly

You can play discs/tracks repeatedly in any play mode.

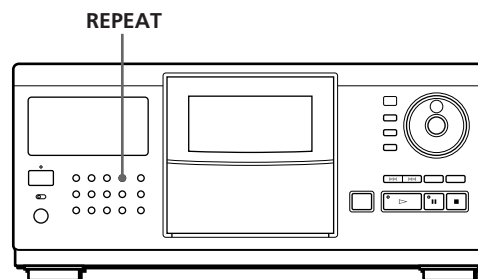

Press REPEAT while playing a disc. "REPEAT" appears in the front panel display. The player repeats the discs/tracks as follows:

When the disc is played in	The player repeats
ALL DISCS Continuous Play (page 10)	All tracks on all discs
1 DISC Continuous Play (page 10)	All tracks on the current disc
ALL DISCS Shuffle Play (page 18)	All tracks on all discs in random order
1 DISC Shuffle Play (page 18)	All tracks on the current disc in random order
Program Play (page 18)	The same program

To cancel Repeat Play

Press REPEAT repeatedly until "REPEAT OFF" appears in the front panel display.

Repeating the current track (Repeat 1)

You can repeat only the current track.

While the track you want is being played, press REPEAT repeatedly until "REPEAT 1" appears in the front panel display.

Playing in Random Order (Shuffle Play)

You can have the player “shuffle” the tracks and play in random order. The player shuffles all the tracks on all discs or on the disc you specified.

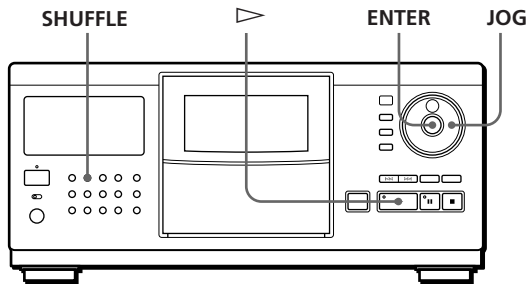

- 1 Press SHUFFLE to select ALL DISCS or 1 DISC Shuffle Play mode. Each time you press SHUFFLE, “ALL DISCS” or “1 DISC” appears in the front panel display.

When you select	The player plays
ALL DISCS	All tracks on all discs in random order. When connected to the second player, the player selects the tracks from both this player and the second player.
1 DISC	All tracks on the selected disc in random order

- 2 When you want to specify the disc for 1 DISC Shuffle Play, turn the JOG dial until the disc number or disc title (see page 23) you want appears in the front panel display.
- 3 Press ENTER or ▷. ALL DISCS or 1 DISC Shuffle Play starts. “[CD]” appears in the front panel display while the player is “shuffling” the discs or the tracks.

To cancel Shuffle Play
Press CONTINUE.

You can start Shuffle Play while playing
Press SHUFFLE, and Shuffle Play starts from the current track.

You can directly select a disc for 1 DISC Shuffle Play See “Selecting a disc directly using the remote” on page 13.

You can go to the next disc during 1 DISC Shuffle Play
Press DISC SKIP +.

You can specify the next disc to play during 1 DISC Shuffle Play
Turn the JOG dial to specify the next disc. After all the tracks on the current disc are played in random order, the next disc starts playing. If you want to skip to the next disc right away, press ENTER while playing the current disc.

Notes

- You cannot specify the next disc to play during ALL DISCS Shuffle Play.
- Even if you press the ■ button or turn off the player during ALL DISCS Shuffle Play, the player remembers which discs/tracks were played and which were not. Therefore, if you want to start ALL DISCS Shuffle Play again from the beginning, be sure to repeat the procedure from Step 1.

Creating Your Own Program (Program Play)

You can arrange the order of the tracks and/or discs to create three different programs and the programs are stored automatically. A program can contain up to 32 “steps” — one “step” may contain a track or a whole disc.

You can also create programs by different procedure using the remote. You can use both the front panel and the on-screen display information when programming in either procedure.

Creating a program on the player

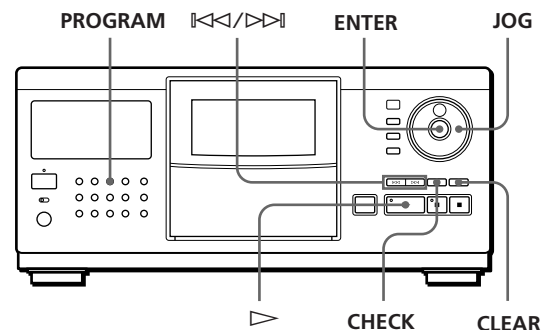

- 1 Press PROGRAM until the program number you want (PROGRAM 1, 2 or 3) appears in the front panel display.
If a program is already stored in the selected program number, the last step of the program appears in the front panel display. When you want to erase the whole program, hold down CLEAR until "ALL CLEAR" appears in the front panel display (see page 20).
- 2 Turn the JOG dial until the disc number you want appears in the front panel display.



- 3 To program a whole disc, skip this step. Press ◀◀/▶▶ until the track number you want appears in the front panel display.

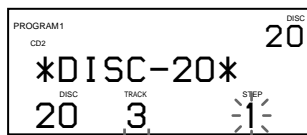

Track number

- 4 Press ENTER or PROGRAM.

The track being programmed

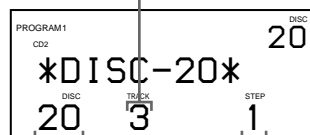

The disc being programmed

Playing order

- 5 To program other discs/tracks, do the following:

To program	Repeat Steps
Other discs	2 and 4
Other tracks on the same disc	3 and 4
Other tracks on other discs	2 through 4

- 6 Press ▷ to start Program Play.

To cancel Program Play

Press CONTINUE.

- 💡 **The programs remain even after Program Play ends**
When you press the ▷ button, you can play the same program again.

- 💡 **When you press PROGRAM during Continuous or Shuffle Play**
The program will be played after the current track.

- 💡 **The programs remain until you erase them**
If you replace discs, the programmed disc and track numbers remain. So, the player plays only the existing disc and track numbers. However, the disc and track numbers that are not found in the player or on the disc are deleted from the program, and the rest of the program is played in the programmed order.

- 💡 **When connected to the second player, you can program tracks/discs of both players in the same program**
When selecting a disc, press PLAYER SELECT repeatedly until "2nd PLAYER" appears in the front panel display. Then select the disc you want to program.

Creating a program using the remote

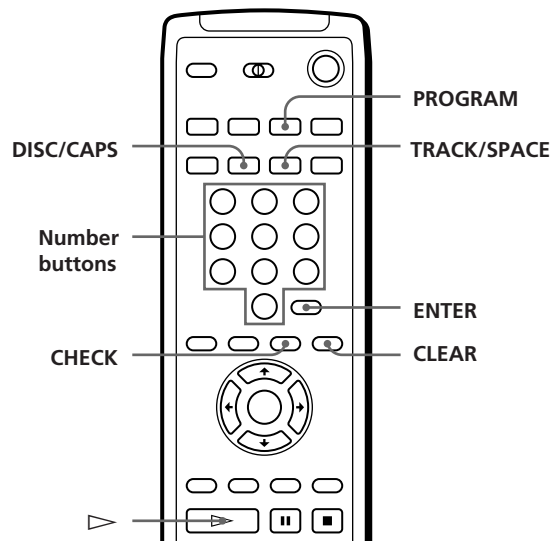

- 1 Press PROGRAM until the program number you want (PROGRAM 1, 2 or 3) appears in the front panel display.
- 2 Press DISC/CAPS.

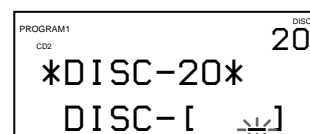

(Continued)

- 3** Press the number button of the disc.

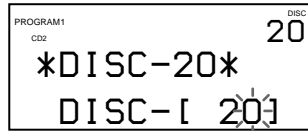

- 4** To program a whole disc, skip this step and go to Step 6. Press TRACK/SPACE.

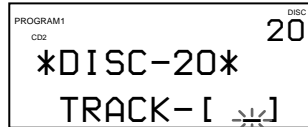

- 5** Press the number button of the track.

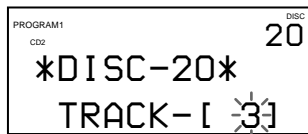

- 6** Press ENTER.

The track being programmed

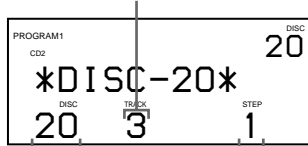

The disc being programmed

Playing order

- 7** To program other discs/tracks, do the following:

To program	Repeat Steps
Other discs	2, 3 and 6
Other tracks on the same disc	4 through 6
Other tracks on other discs	2 through 6

- 8** Press \triangleright to start Program Play.

To cancel Program Play

Press CONTINUE.

Checking the programmed order

You can check your program before or after you start playing.

Press CHECK.

Each time you press this button, the front panel display shows the disc and track numbers of each step in the programmed order. (When a whole disc is programmed as one step, "ALL" appears instead of the track number.) After the last step in the program, the front panel display shows "END" and returns to the original display.

Changing the programmed order

You can change your program before you start playing.

To	You need to
Erase a track or disc	Press CHECK until the track or disc you do not want appears in the front panel display, then press CLEAR
Erase the last track or disc in the program	Press CLEAR. Each time you press the button, the last track or disc will be cleared.
Add tracks or discs to the end of the program	Follow the programming procedure
Change the whole program completely	Hold down CLEAR until "ALL CLEAR" appears in the front panel display to erase the whole program, then create a new program following the programming procedure

Erasing the programs stored in memory

- 1 Press PROGRAM repeatedly in the stop mode until the program number (PROGRAM 1, 2 or 3) you want to erase appears in the front panel display.
- 2 Hold down CLEAR until "ALL CLEAR" appears in the front panel display.

Creating programs while checking the on-screen display information

While creating programs

You can select the discs/tracks by checking the titles. While selecting a disc, the on-screen display shows the disc titles in the order of the disc number.



While selecting a track, the on-screen display shows the track titles.

Disc number and disc title

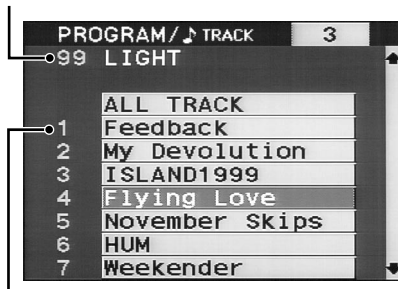

Track number

When checking the programs

The on-screen display shows the disc and track numbers of each step in the programmed order.

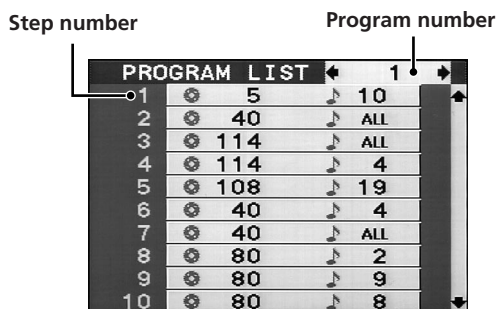

The program number (1, 2 or 3) you are checking appears in the upper right corner of the on-screen display.

Playing Alternately (X-Fade Play)

When you connect the second player (see page 6), you can play the discs/tracks in this player and those in the second player alternately in Continuous Play and Shuffle Play modes.

Each time the current player changes to the other player, the sound from both players is mixed. The current player ends play by fading out, and the other player starts play by fading in.

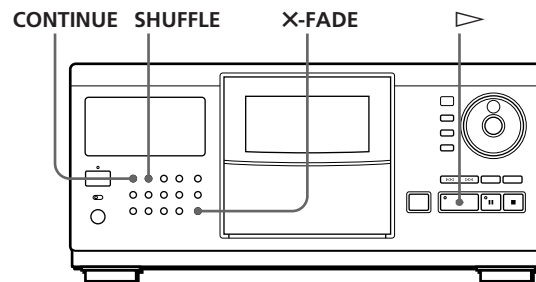

- 1 Press CONTINUE or SHUFFLE to select the play mode you want.
- 2 Press X-FADE. "X-FADE" appears in the front panel display and the X-FADE button lights up.
- 3 Press ▷ to start playing.

When you select	The player alternately plays
ALL DISCS Continuous Play (page 10)	Tracks of all discs from each player in the order of the disc number
1 DISC Continuous Play (page 10)	Tracks on the selected discs from each player
ALL DISCS Shuffle Play (page 18)	Tracks of all discs from each player in random order
1 DISC Shuffle Play (page 18)	Tracks on the selected discs from each player in random order

The player automatically selects the repeat mode when X-Fade Play starts. So, the play doesn't stop if the player has played all the discs/tracks in one player ahead of the other player.

(Continued)

To cancel X-Fade Play

Press X-FADE again.

Notes

- You cannot use the Sort and Group Play functions during X-Fade Play.
- During X-Fade Play, the PLAYER SELECT, INPUT and ENTER buttons and the JOG dial do not work.
- You cannot use the X-Fade Play function when connected to the CD player CDP-CX153.

Playing Using a Timer

You can start playing a disc at any time you want by connecting a timer (not supplied). Please also refer to the instructions for the timer if you need help.

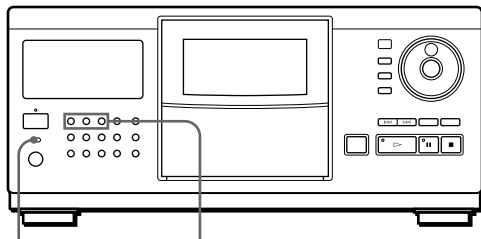

TIMER Play mode buttons

- 1** Press one of the play mode buttons to select the play mode you want.
- 2** Set TIMER on the player to PLAY.
- 3** Set the timer to the time you want.
The player turns off. When the set time comes, the player turns on and starts playing.
- 4** After you are finished using the timer, set TIMER on the player to OFF.

Using a Sony Receiver With the On-Screen Display Control Function

If you have a Sony receiver (amplifier) with the on-screen display control function, you can control the player using the remote supplied with the receiver (amplifier).

- 1** Connect the player to the VIDEO jack on the receiver (amplifier), and register the IR code of the jack to which this player is connected as "CONTROL A1/CD2."
- 2** Click LIST on the on-screen display using the remote supplied with the receiver (amplifier). The on-screen display changes to the CD player information display.
- 3** Click EXIT to return to the receiver (amplifier) information display.

For details on this function, refer to the instructions supplied with the receiver (amplifier).

Notes

- When the CD player information display does not fit inside the receiver's (amplifier's) on-screen display control panel, adjust the position using the GRAPHIC POSITION function on the receiver (amplifier).
- The CD player information display may return to the receiver (amplifier) information display while playing discs, depending on the connected receiver (amplifier).
- There might be a difference between the remote's sensitivity (FEELING) with the CD player information display and the receiver (amplifier) information display.

Storing Information About CDs (Custom Files)

What You Can Do With the Custom Files

The player can store four types of information called "Custom Files" for each disc. Once you have stored Custom Files for a disc, the player automatically recalls what you have stored whenever you select the disc. Note that Custom Files will be erased if you do not use the player for about one month.

You can store this information:

When you use	You can
Disc Memo (page 23)	Label discs with disc and track titles* and artist names using up to 16 characters for each entry
Group File (page 26)	Group discs in up to eight groups to locate them easily
Delete File (page 28)	Delete unwanted tracks and store only the tracks you want
Hit List (page 29)	Store the tracks you play frequently

* You can label up to 16 tracks.

Where are Custom Files stored?

Custom Files are stored not on the disc, but in the player's memory. It means you cannot use Custom Files when you play the disc on another player.

If you replace discs you have filed in the Custom Files

The Custom File information you have stored remains, since each Custom File information is assigned to each slot. Erase all Custom Files (Disc Memo, Delete File, Group File and Hit List) of the old disc, then file the new disc information in the Custom Files.

Erasing all Custom Files of all discs

Turn off the player. While holding down CLEAR, press POWER to turn on the player. "ALL ERASE" appears in the front panel display, and all Custom Files will be erased after a while.

Erasing all Custom Files of a disc

Select the disc you want to clear. While holding down CLEAR, press INPUT.

💡 When you select a CD-TEXT disc

- The CD-TEXT information (disc title, artist name and track titles) is stored as the Disc Memo automatically. If an entry has more than 16 characters, the first 16 characters are stored (see also page 12). When you replace a disc with a CD-TEXT disc, the CD-TEXT information replaces the Custom File for the old disc automatically. You cannot change the Disc Memo for a CD-TEXT disc.
- You can group CD-TEXT discs in the same way as normal discs.
- If you connect a second player that can read the CD-TEXT information, the CD-TEXT information is stored as the Disc Memo automatically when you select a CD-TEXT disc in that player. However, if the second player is the CDP-CX250, artist names cannot be stored.

💡 When storing the Disc Memo and Group File information

You might find it difficult to input all the track and disc information of 200 discs using the controls on the player or the remote. To make the task easier, you can use an IBM-compatible PC keyboard (see "Storing Custom File information using a keyboard" on page 28).

Labeling Discs (Disc Memo)

You can store the disc title, artist name and track titles of each disc using up to 16 characters for each entry, and have the player display the Disc Memo each time you select the discs/tracks.

💡 You can label discs while the front cover is open

Labeling discs with disc titles

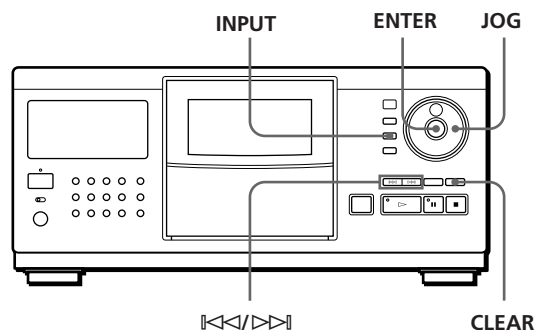

- Turn the JOG dial to select the disc. When you label a disc with the front cover closed, the disc number of the disc at the playing position appears. When you label a disc with the front cover open, the disc number at the loading position appears.

(Continued)

Storing Information About CDs (Custom Files)

- 2 Press INPUT.
- 3 Turn the JOG dial until "DISC MEMO" appears in the front panel display, then press ENTER. The flashing cursor (◀) appears.
- 4 Turn the JOG dial until the character you want appears in the front panel display. The cursor disappears and the first space for the disc title flashes. As you turn the JOG dial clockwise, the characters appear in the following order. Turn the JOG dial counterclockwise to go back to the previous character.

(space) A B C D E F G H I J K L M N O P Q R S T U
V W X Y Z a b c d e f g h i j k l m n o p q r s t u v w
x y z 0 1 2 3 4 5 6 7 8 9 ! " # \$ % & ' () * + , - . / : ; <
= > ? @ [\] ^ _ ` { | } ~



- 5 Press ENTER to select the character. The selected character lights up, and the flashing cursor appears to indicate the next space to be input.



If you have made a mistake

Press CLEAR and begin again by inputting the correct characters.

- 6 Repeat Steps 4 and 5 to input more characters.

If you want to input other Disc Memo information (artist name or track titles) of the same disc sequentially

Press ENTER repeatedly until the cursor goes to the space for the item you want, and you can input the information.

- 7 Press INPUT to store the disc title. The disc title lights up in the front panel display.



Repeat Steps 1 through 7 to assign disc titles to other discs.

Labeling discs with artist names

- 1 Turn the JOG dial to select the disc.
- 2 Press INPUT.
- 3 Turn the JOG dial until "ARTIST NAME" appears in the front panel display, then press ENTER. "New Artist" flashes in the front panel display.
- 4 Press ENTER. The flashing cursor (◀) appears.
- 5 Input the artist name following Steps 4 through 7 in "Labeling discs with disc titles" on page 23.

💡 You can select the artist name without inputting when labeling another disc by the same artist

After pressing the ENTER button in Step 3 above, turn the JOG dial. As you turn the JOG dial, the front panel display shows the artist names which have been assigned to other discs. Press ENTER to select the artist name for the current disc.

If you correct the artist name, all discs by the same artist will be corrected.

Labeling each track

- 1 Turn the JOG dial to select the disc.
- 2 Press INPUT.
- 3 Turn the JOG dial to select the track, then press ENTER. The flashing cursor (◀) appears.
- 4 Input the track title following Steps 4 through 7 in "Labeling discs with disc titles" on page 23.

Labeling discs/tracks using the remote

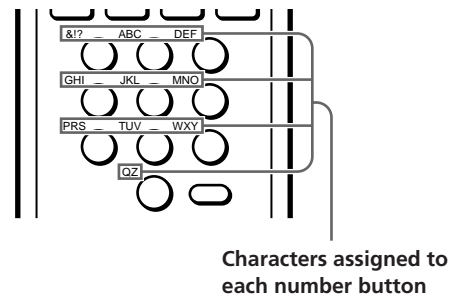
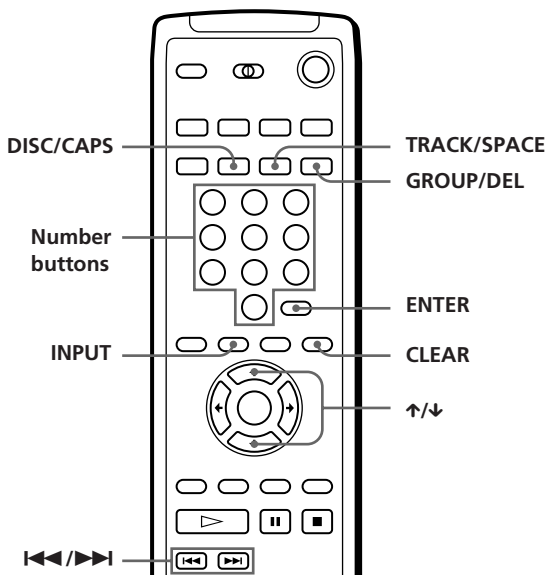

Example: To select the letter E
Press the number button 3 twice.

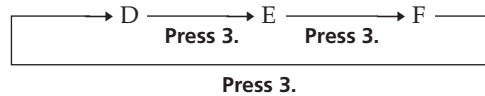

To insert a space, press TRACK/SPACE once.
To input a number, press DISC/CAPS twice in Step 4, then press the number button you want.
To input symbols, press the number button 1 repeatedly until the symbol you want appears in the front panel display.

- 1** Select a disc following Steps 1 and 2 in “Selecting a disc directly using the remote” on page 13, then press ENTER.
- 2** Press INPUT.
- 3** Press \uparrow/\downarrow repeatedly until the item you want (DISC MEMO, ARTIST NAME or the track number) appears in the front panel display, then press ENTER.
When you select ARTIST NAME, press ENTER again.
The flashing cursor (\blacktriangleleft) appears.
- 4** Press DISC/CAPS to find the letter type you want. Each time you press the button, the letter type changes cyclically among capital letters (AB), lower case letters (ab) and numbers (12). The selected letter type appears in the upper right corner of the front panel display.
- 5** Press the number button corresponding to the character you want (indicated beside each number button).
The cursor disappears and the first space for the Disc Memo flashes.
Each time you press the button, the character changes cyclically among the ones indicated beside the button.
- 6** Press ENTER to select the character.
The selected character lights up, and the flashing cursor appears to indicate the next space to be input.
You can also go to the next space by pressing other number buttons.
- 7** Repeat Steps 4 through 6 to input more characters.
If you want to assign the other information (disc title, artist name or track titles) to the same disc, repeat Steps 2 through 7.
- 8** Press INPUT to store the Disc Memo.
The Disc Memo lights up in the front panel display.
Repeat Steps 1 through 8 to assign Disc Memos to other discs.
You can change the disc to which you want to assign Disc Memo by pressing the \leftarrow/\rightarrow buttons in Step 3.



You can select the artist name without inputting when labeling another disc by the same artist

After pressing the ENTER button in Step 3 above, press the \leftarrow/\rightarrow buttons until the artist name you want appears in the front panel display. Press ENTER to select the artist name for the current disc.

Storing Information About CDs (Custom Files)

 If you have made a mistake while inputting a character

To correct a character which has been input

- 1 Press **◀** or **▶** until the cursor moves next to the incorrect character.



- 2 Press **GROUP/DEL** to delete the incorrect character.



- 3 Input the correct character.



To correct the character currently being input

- 1 Press **GROUP/DEL** to delete the incorrect character.
- 2 Input the correct character.

To insert a character between the input characters

Press **◀** or **▶** until the cursor moves next to the point you want to insert, then input the character.

Erasing the Disc Memo

- 1 Select the disc whose Disc Memo you want to erase.
- 2 Press **INPUT**.
- 3 Turn the **JOG** dial (when using the remote, press **↑/↓**) until the item you want to clear (disc title, artist name or track title) appears in the front panel display, then press **ENTER**.
- 4 Press **CLEAR**.
The Disc Memo disappears.
- 5 Press **INPUT**.

Grouping Discs (Group File)

You might find that too many discs make it hard to find the disc you want. This player has a feature that lets you classify discs into eight groups and label each group with category etc. using up to 16 characters (Group Memo). One disc can be put into only one group.

Once you classify discs, you can enjoy Continuous, Shuffle or Repeat Play only within a certain group (Group Play).

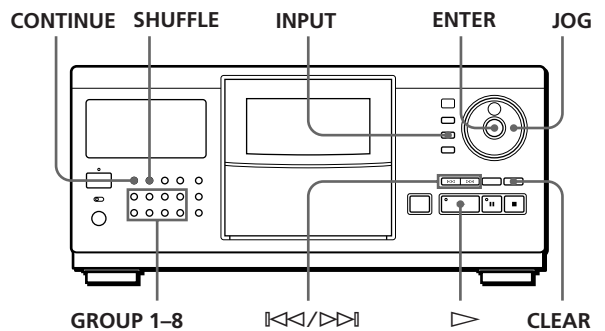

Putting discs into groups

- 1 Press **CONTINUE** or **SHUFFLE** before you start playing.
- 2 Turn the **JOG** dial to select the disc which you want to put into a group.
- 3 Press **INPUT**.
- 4 Turn the **JOG** dial until "GROUP FILE" appears in the front panel display, then press **ENTER**.
If the disc has not been put into any group, "NOT FILED" appears in the front panel display.
- 5 Turn the **JOG** dial until the group number you want (e. g., **GROUP 1**) appears in the front panel display.



Storing Information About CDs (Custom Files)

- 6** Press ENTER to select the group.
The group file indication lights up in the front panel display and the flashing cursor (◀) appears to indicate the first space for the Group Memo.
- 7** Input the group name (Group Memo) following Steps 4 through 6 in "Labeling discs with disc titles" on page 23.
- 8** Press INPUT to store the Group Memo.

Erasing the Group Memo

- 1** Follow Steps 1 through 4 in "Putting discs into groups" to select the Group Memo you want to erase.
- 2** Press CLEAR.
- 3** Press INPUT.

Playing discs in a group (Group Play)

You can enjoy Continuous or Shuffle Play within a group.



- 1** Press CONTINUE or SHUFFLE to select the play mode you want before you start playing.

When you select	The player plays
ALL DISCS Continuous Play	All tracks on all discs in the group consecutively
1 DISC Continuous Play	All tracks on the specified disc in the group consecutively
ALL DISCS Shuffle Play	All tracks on all discs in the group in random order
1 DISC Shuffle Play	All tracks on the specified disc in the group in random order

- 2** Press one of the GROUP 1-8 buttons to select the group and press ▷.
Group Play starts from the disc which is the most upward number and located closest to the playing position. If the disc at the playing position is put into the selected group, the play starts from that disc.

You can specify the first disc to play when starting Group Play

After selecting the group, turn the JOG dial to select the disc, then press ENTER.

 **You can start Group Play using the remote** 
Before you start playing, press GROUP/DEL, the number button of the group you want to play, then ENTER.

Note

If "NO ENTRY" appears in the front panel display, no disc has been put into the selected group.

Deleting discs from a group

- To delete a disc from a group
 - 1 Follow Steps 1 through 4 in "Putting discs into groups" on page 26 to select the disc.
 - 2 Turn the JOG dial (when using the remote, press ← repeatedly) until "NOT FILED" appears in the front panel display, then press ENTER.
 - 3 Press INPUT.
- To delete all discs from a group at once
Press one of the GROUP 1-8 buttons you want to clear, then press CLEAR for more than one second.

Checking the Group File information using the on-screen display

You can check the Group Memos and disc titles stored in each group.

Checking the Group Memos

Press GROUP/DEL.

The on-screen display shows all the Group Memos.



Checking the disc titles in each group

After pressing GROUP/DEL, press the number button of the group you want.



Storing Information About CDs (Custom Files)

Storing Custom File Information Using a Keyboard

You can store the Disc Memo and Group File for one disc sequentially using an IBM-compatible PC keyboard* for USA (not supplied).

* Power consumption must be 120 mA or less.

Keyboard jack

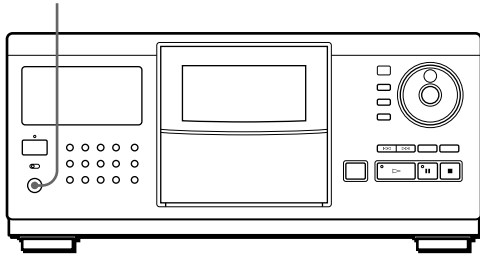

- 1 Connect a keyboard to the keyboard jack on the front panel of the player.

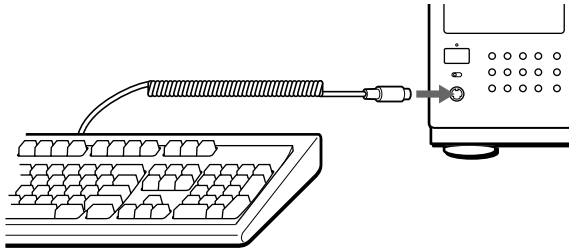

- 2 After selecting the disc you want on the player, press the Enter key.
- 3 Press the cursor keys (↑/↓) to select the item you want (disc title, artist name, group file or track title).

- **When you select ARTIST NAME**
“New Artist” appears in the on-screen display. Press the ENTER key and go to Step 4.
If the same artist name has been assigned to other discs, press the cursor keys (←/→) repeatedly until the artist name you want appears in the on-screen display, then press the ENTER key. In this case, skip Step 4.
- **When you select GROUP FILE**
Press the cursor keys (←/→) until the group number you want appears in the on-screen display, then press the ENTER key.

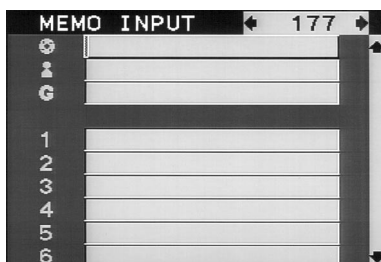

- 4 Input the characters you want, then press the ENTER key.
To input the other information, repeat Steps 3 and 4.

- 5 Press the Esc key to store the information.



You can delete all characters of selected item

While holding down the Shift key, press the Delete key.

Notes

- If the cursor keys do not work correctly and you cannot complete the task using the keyboard, disconnect the keyboard then reconnect it to the player.
- If the keyboard is not the USA model, the characters may be input differently from those on the keys.

Storing Specific Tracks (Delete File)

You can delete unwanted tracks and store only the tracks you want. When you select the disc containing a Delete File, you can play only the remaining tracks.

CONTINUE SHUFFLE

JOG

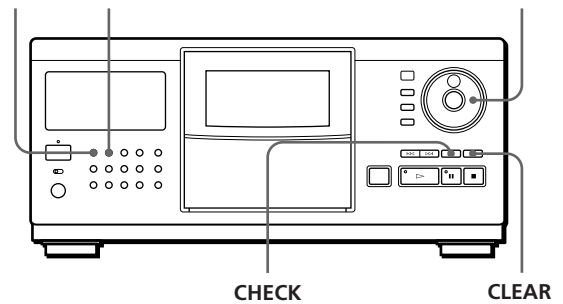

- 1 Press CONTINUE or SHUFFLE before you start playing.
- 2 Turn the JOG dial to select the disc.
- 3 Press CHECK repeatedly until the track you want to delete appears in the front panel display.

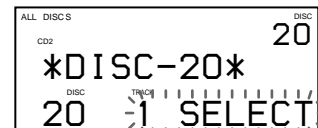

- 4 Press CLEAR.
“DELETE FILE” appears, and “DELETE” flashes in the front panel display.



If you want to recover the track, press CLEAR again.

- Repeat Steps 3 and 4 to delete more tracks.

You can recover all the tracks you have deleted
Press CHECK, then hold down CLEAR until "ALL SELECT" appears in the front panel display.

Note

The deleted tracks are skipped even in the Shuffle or Program Play mode (when the whole disc containing a Delete File is programmed as one step).

Storing Your Favorite Tracks (Hit List)

You can store the tracks you play frequently and select those tracks immediately by checking the track numbers or titles (see page 24) in the Hit List. You can put up to 50 tracks in the Hit List.

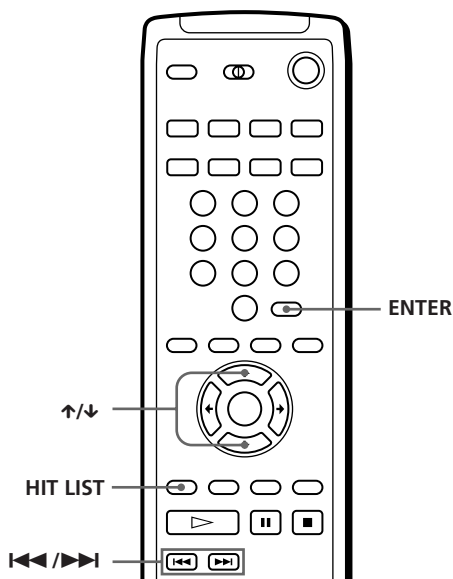
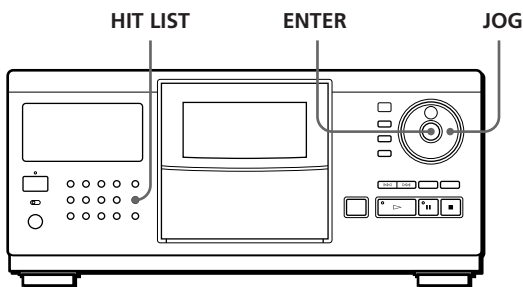

Putting tracks into the Hit List

Press HIT LIST while playing your favorite track. "LIST IN" appears in the front panel display.

Playing tracks in the Hit List

- Press HIT LIST before you start playing. "HIT LIST " appears in the front panel display.
- Turn the JOG dial or press ⏮/⏭ until the track you want appears in the front panel display. When using the remote, press ↑/↓.
- Press ENTER to start playing the track.

You can check the tracks in the Hit List using the on-screen display

When you press the HIT LIST button, the on-screen display shows the tracks in the Hit List.

Hit List			
1	5	10	
2	147	7	
3	147	1	
4	147	5	
5	40	8	
6	80	1	
7	80	9	
8	120	12	
9	120	7	
10	5	1	

Notes

- You cannot arrange the order of the tracks in the Hit List.
- The track you select in Step 2 will be listed as the first track in the Hit List.
- If you input the 51st track into the Hit List, the 50th track will be replaced.

Precautions

On safety

- Caution — The use of optical instruments with this product will increase eye hazard.
- Should any solid object or liquid fall into the cabinet, unplug the player and have it checked by qualified personnel before operating it any further.

On power sources

- Before operating the player, check that the operating voltage of the player is identical with your local power supply. The operating voltage is indicated on the nameplate at the rear of the player.
- The player is not disconnected from the AC power source (mains) as long as it is connected to the wall outlet, even if the player itself has been turned off.
- If you are not going to use the player for a long time, be sure to disconnect the player from the wall outlet. To disconnect the AC power cord (mains lead), grasp the plug itself; never pull the cord.
- AC power cord must be changed only at the qualified service shop.

On placement

- Place the player in a location with adequate ventilation to prevent heat build-up in the player.
- Do not place the player on a soft surface such as a rug that might block the ventilation holes on the bottom.
- Do not place the player in a location near heat sources, or in a place subject to direct sunlight, excessive dust or mechanical shock.

On operation

- If the player is brought directly from a cold to a warm location, or is placed in a very damp room, moisture may condense on the lenses inside the player. Should this occur, the player may not operate properly. In this case, leave the player turned on for about an hour until the moisture evaporates.

On adjusting volume

- Do not turn up the volume while listening to a portion with very low level inputs or no audio signals. If you do, the speakers may be damaged when a peak level portion is played.

On cleaning

- Clean the cabinet, panel and controls with a soft cloth slightly moistened with a mild detergent solution. Do not use any type of abrasive pad, scouring powder or solvent such as alcohol or benzine.

On transportation

- When transporting the player, press OPEN then remove all the discs from the player and turn the power off.

If you have any questions or problems concerning your player, please consult your nearest Sony dealer.

Notes on CDs

On handling CDs

- To keep the disc clean, handle the disc carefully.
- Do not stick paper or tape on the disc.

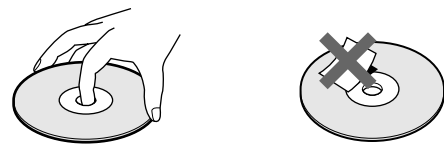

Not this way

- Do not expose the disc to direct sunlight or heat sources such as hot air ducts, nor leave it in a car parked in direct sunlight as there can be considerable rise in temperature inside the car.
- After removing a disc from the disc slot, store the disc in its case.

On cleaning

- Before playing, clean the disc with a cleaning cloth. Wipe the disc from the center out.

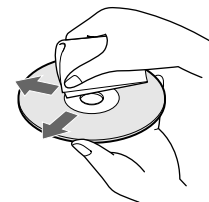

- Do not use solvents such as benzine, thinner, commercially available cleaners or anti-static spray intended for vinyl LPs.

Troubleshooting

If you experience any of the following difficulties while using the player, use this troubleshooting guide to help you remedy the problem. Should any problem persist, consult your nearest Sony dealer.

There is no sound.

- ➔ Check that the player is connected securely.
- ➔ Make sure you operate the amplifier correctly.

The CD does not play.

- ➔ There is no CD in a slot (“–NO DISC–” appears).
Insert a CD.
- ➔ Insert the CD with the label side facing right.
- ➔ Clean the CD (see page 30).
- ➔ Moisture has condensed inside the player. Press OPEN and leave the player turned on for about an hour (see page 30).

The remote does not function.

- ➔ Remove obstacles in the path of the remote and the player.
- ➔ Point the remote at the remote sensor  on the player.
- ➔ Replace all the batteries in the remote with new ones if they are weak.
- ➔ Set the CD 1/2/3 switch on the remote according to the position of the COMMAND MODE selector displayed in the front panel display (see page 6).

The player functions incorrectly.

- ➔ The microcomputer chips may be operating incorrectly. Disconnect the AC power cord, then reconnect it to the wall outlet to reset the player.

“Error” appears in the front panel display.

- ➔ Consult your nearest Sony dealer.

Specifications

Compact disc player

Laser	Semiconductor laser ($\lambda = 780 \text{ nm}$) Emission duration: continuous
Laser output	Max 44.6 μW^* * This output is the value measured at a distance of 200 mm from the objective lens surface on the Optical Pick-up block with 7 mm aperture.
Frequency response	20 Hz to 20 kHz $\pm 0.3 \text{ dB}$
Dynamic range	More than 98 dB
Harmonic distortion	Less than 0.0027%

Outputs

	Jack type	Maximum output level	Load impedance
LINE OUT	Phono jacks	2 V (at 50 kilohms)	Over 10 kilohms
DIGITAL OUT (OPTICAL)	Optical output connector	-18 dBm	Wave length: 660 nm
MONITOR OUT	Phono jack	1 Vp-p	75 ohms, unbalanced, sync negative

General

Power requirements	120 V AC, 60 Hz
Power consumption	19 W
Dimensions (approx.) (w/h/d)	When the front cover is closed 430 × 198.5 × 477 mm (17 × 7 7/8 × 18 7/8 in.) incl. projecting parts When the front cover is open 430 × 198.5 × 600 mm (17 × 7 7/8 × 23 5/8 in.) incl. projecting parts
Mass (approx.)	9.6 kg (21 lbs 2 oz)

Supplied accessories

- Audio cord (2 phono plugs – 2 phono plugs) (1)
- Video cord (1)
- Remote commander (remote) (1)
- Sony SUM-3 (NS) batteries (2)
- CD booklet holders (2)
- Label (1)

Design and specifications are subject to change without notice.

Index

A, B

- AMS 16
- Automatic Music Sensor 16

C

- CD-TEXT 12
- Connecting 4
- Continuous Play 10
- Controlling another CD player 6
- X-Fade Play 21
- Custom Files
 - Delete File 28
 - Disc Memo 23
 - Group File 26
 - Hit List 29
 - what you can do with 23

D

- Delete File 28
- Disc Memo 23

E, F

- Erasing
 - Custom Files 23
 - Delete File 29
 - Disc Memo 26
 - Group File 27
 - Group Memo 27
 - programs 20

G

- Group File 26
- Group Memo 26
- Group Play 27

H

- Handling CDs 30
- Hookups
 - overview 4

I

- Inserting CDs 8

J, K

- JOG dial 8

L

- Labeling
 - discs with disc titles 23
 - discs with artist names 24
 - each track 24
- Locating
 - a specific track 16
 - a specific point 16

- by monitoring 17
- by observing the display 17
- directly 17
- discs 13
- using AMS 17

M, N

- Memo Scan 14

O

- On-screen display 13

P, Q

- Playback
 - Continuous Play 10
 - X-Fade Play 21
 - Group Play 27
 - Program Play 18
 - Repeat Play 17
 - Shuffle Play 18
 - using a timer 22
- Player Control 6
- Program
 - changing 20
 - checking 20
 - erasing 20

R

- Remote control 4
- Repeating 17
- Rotary table 8

S

- Searching. *See* Locating
- Selecting a disc 13
- Shuffle Play
 - on all discs 18
 - on one disc 18
- Sorting out discs 14
 - by disc number 15
 - by disc title 15
 - by artist name 15
- Specifying the next disc 16
- Storing
 - information about CDs 23
 - specific tracks 28
 - your favorite tracks 29

T

- Timer Play 22
- Total playing time 12
- Troubleshooting 31

U, V, W, X, Y, Z

- Unpacking 4
- Using a Sony receiver 22

Names of controls

Buttons

- CHECK 20, 28
- CLEAR 20, 28
- CONTINUE 10
- X-FADE 21
- DISC/CAPS 13, 19, 25
- DISC SKIP 11
- ENTER 11
- EXTRA 12
- GROUP/DEL 26, 27
- GROUP 1-8 27
- HIT LIST 29
- INPUT 23, 26
- MEMO SCAN 14
- Number 13
- OPEN 8
- PLAYER SELECT 14
- PROGRAM 19
- REPEAT 17
- SHUFFLE 18
- SORT 14
- TIME/TEXT 12
- TRACK/SPACE 17, 20
- ⏪/⏩ 17
- ▷ 11
- ⏸ 11
- 11
- ◀◀/▶▶ 17
- ↑/↓/←/→ 14, 17, 25, 29

Switches

- CD1/2/3 6
- POWER 10
- TIMER 22
- TV/VIDEO 13

Jacks

- CONTROL A1 6
- LINE IN 6
- LINE OUT 5
- MONITOR OUT 5

Connector

- DIGITAL OUT (OPTICAL) 6

Others

- AC OUTLET 6
- COMMAND MODE selector 7
- Disc slots 8
- Front cover 8
- Front panel display 12
- JOG dial 8, 10
- Rotary table 8
- Ⓜ 4