

# OD4 Conditioning Module

---



user manual



# 1.0: Index

<b>Section</b>	<b>Title</b>	<b>Page</b>	<b>Section</b>	<b>Title</b>	<b>Page</b>
1.0	Index . . . . .	1	4.6.1	Voltage Connections. . . . .	10
2.0	Safety Information . . . . .	2	4.6.2	Current Connections . . . . .	11
3.0	Introduction . . . . .	4	4.7	Using an EMC Cable Gland . . . . .	12
3.1	OD4 Mk2 Enhancements . . . . .	4	5.0	Setting up the Transducer and OD4 . . .	13
4.0	Installation . . . . .	5	5.1	Links Explained . . . . .	14
4.1	Mounting . . . . .	5	5.2	Basic Procedure . . . . .	15
4.2	Operational Environment . . . . .	6	5.3	Sensitivity and the X2, X4,DIV2 Links . . . .	19
4.2.1	Residential, Commercial & Light Industrial Environments . . . . .	6	6.0	Half-Bridge Version. . . . .	20
4.2.2	Industrial Environments . . . . .	6	7.0	Specifications . . . . .	20
4.3	Electrical Connections . . . . .	7	7.1	Electrical . . . . .	20
4.4	Connecting the Transducer . . . . .	9	7.2	Mechanical and Connections . . . . .	22
4.5	Connecting the Power Supply . . . . .	10	7.3	Environmental. . . . .	22
4.6	Connecting the Signal Out . . . . .	10	7.4	Notes . . . . .	.23
1.0 Index				Return Of Goods	
				Solartron Sales Offices	

# 2.0: Safety Information

---

## Terms in this Manual

**WARNING** statements identify conditions or practices that could result in personal injury or loss of life.

**CAUTION** statements identify conditions or practices that could result in damage to the equipment or other property.

## Symbols in this manual



This symbol indicates where applicable cautionary or other information is to be found.

## WARNINGS:

### Do not operate in explosive atmosphere

To avoid explosion, do not operate this equipment in an explosive atmosphere.

### Safety Critical Environments

This equipment is not intended for use in a safety critical environment.

## CAUTION:

### Low Voltage

This equipment operates at below the SELV and is therefore outside the scope of the Low Voltage Directive.

This equipment is designed to work from a low voltage DC supply. Do not operate this equipment outside of specification.

## 2.0: Safety Information

---

### CAUTION:

#### Electrostatic Discharge

This equipment is susceptible to **ESD** (Electrostatic Discharge) when being installed or adjusted, or whenever the case cover is removed. To prevent ESD related damage, handle the conditioning electronics by its case and do not touch the connector pins. During installation, follow the guidelines below.

- Ensure all power supplies are turned off.
- If possible, wear an ESD strap connected to ground. If this is not possible, discharge yourself by touching a metal part of the equipment into which the conditioning electronics is being installed.
- Connect the transducer and power supplies with the power switched off.
- Ensure any tools used are discharged by contacting them against a metal part of the equipment into which the conditioning electronics is being installed.
- During setting up of the conditioning electronics, make link configuration changes with the power supply turned off. Avoid touching any other components.
- Make the final gain and offset potentiometer adjustments, with power applied, using an appropriate potentiometer adjustment tool or a small insulated screwdriver.

## 3.0: Introduction

---

The OD4 MK2 is a development of the original OD4. It is a compact conditioning module powered from a single DC supply. Adjustable gain and zero controls are provided for use with the complete range of Solartron LVDT and half-bridge transducers.\* The unit is of robust construction, housed in a die cast aluminium box providing a substantial degree of mechanical protection.

The OD4 MK2 incorporates its own voltage regulation for operation from 10-30 VDC and can provide outputs of up to  $\pm 10$  V together with  $\pm 20$  mA.

### 3.1: OD4 MK2 Enhancements

The OD4 MK2 has been designed as a form, fit and function replacement for the original OD4, but with several enhancements.

- Wider gain range, allowing ALL Solartron transducers to be connected without the need for attenuation resistors.
- Up to  $\pm 10$  V dc and  $\pm 20$  mA are available for all gain settings.
- Fixed and variable offsets make setting of uni-polar output easier.
- Gain and offset adjustment are fully independent.
- Selectable transducer excitation frequency.
- Selectable transducer load resistances.
- Selection between forward and reverse connection.
- Fully CE Compliant.
- Half-Bridge transducers can now be accommodated with simple plug wiring changes.\*

\* For half-bridge only variant see section 6.0.

# 4.0: Installation

---

## 4.1: Mounting

The OD4 may be mounted in a variety of ways and in any attitude. Ensure that there is enough space for the cover to be removed to allow for internal adjustments. Space should also be allowed for the transducer connector, EMC glands (if fitted) and cabling. It is recommended that the OD4 case be connected to earth or chassis. This earth connection is not a safety earth, but is part of the overall electrical screening scheme.

### Underside Mounting

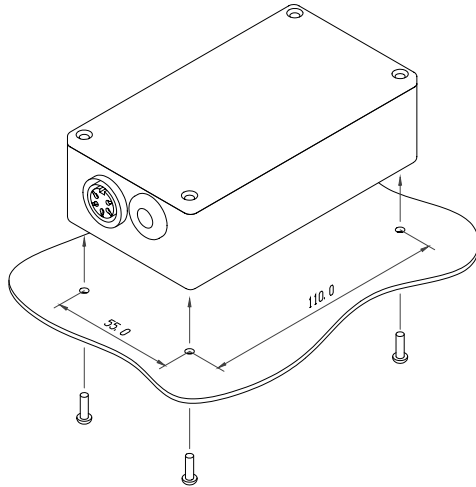

### Top-Side Mounting

Note: If replacing OD4 MKI a retrofit mounting kit is available if repositioning holes is not possible.

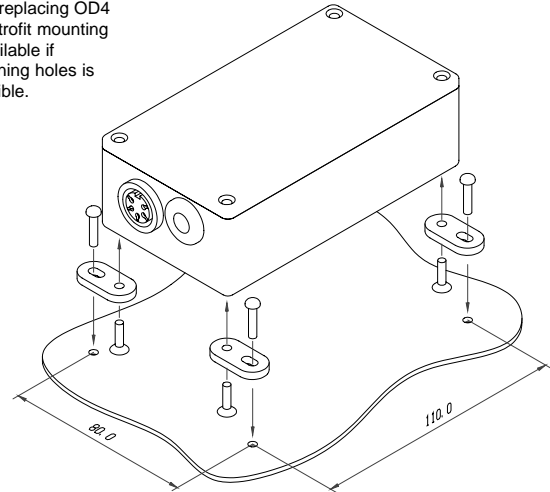

# 4.0: Installation (continued)

---

## 4.2: Operational Environment

This section discusses the type of installation required depending on the electrical environment.

### 4.2.1: Residential, Commercial and Light Industrial Environments

Typically, this will be an office, laboratory or industrial environment where there is no equipment likely to produce high levels of electrical interference, such as welders or machine tools.

Connections may be made using twisted, unscreened wire. This is a cost effective option and will give good performance in this environment.

Standard equipment wire such as 7/0.2 (24AWG) can be twisted together as required. Standard data cable such as generic CAT5 UTP will also give good performance.

### 4.2.2: Industrial Environments

Typically, this will be an industrial environment where there is equipment likely to produce high levels of electrical interference, such as welders, machine tools, cutting and stamping machines.

Connections should be made using screened cable. Braided or foil screened cables may be used. The cable screen should be connected to the OD4 case at cable entry point. The case of the OD4 should be connected to a local ground. An EMC cable gland is recommended. This is supplied with the OD4.

When selecting the type of wire or cable to be used, consider the following parameters:

- Screening.
- Conductor size (resistance).
- Mechanical aspects such as flexibility and robustness.

This is not a complete list. Installations may require other special cable characteristics.





# 4.0: Installation (continued)

---

## 4.3: Electrical Connections

### Power Supply and Signal Out wires from one end only

Connections to the power supply should be routed to one side as shown. This helps to reduce interference between power supply wires and the more sensitive parts of the circuitry.

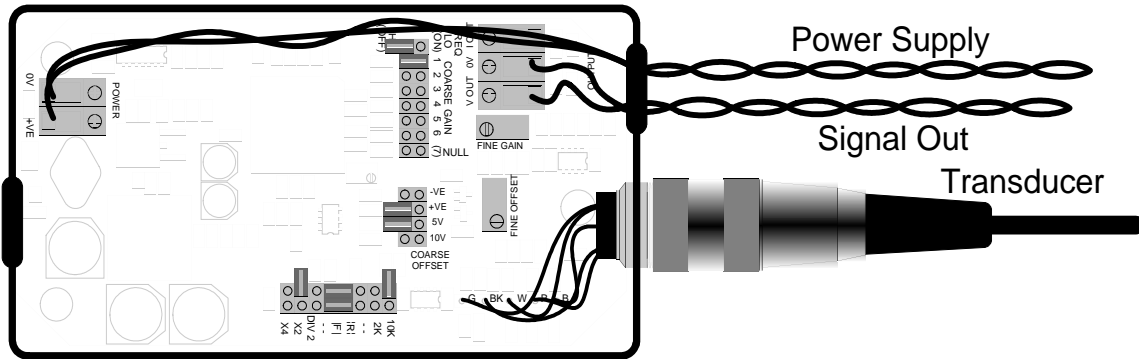

A technical note explaining good practice for cable installation and routing can be downloaded from [www.solartronmetrology.com](http://www.solartronmetrology.com).

# 4.0: Installation (continued)

## 4.4: Connecting the Transducer

Transducers fitted with a 5-pin DIN plug are simply screwed into the case mounted socket. Transducers not fitted with a plug should be wired to the plug supplied. For the half-bridge only variant see section 6.0.

LVDT Electrical Connections	
Red and Blue	Energising
Green and White	Signal
Yellow	Secondary Centre Tap
Red and White	In Phase for Inward Displacement
Black	Transducer Body Ground

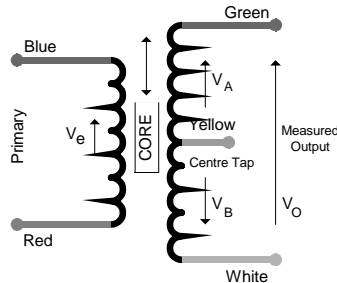

Half-Bridge Electrical Connections	
Red and Blue	Energising
Yellow	Signal
Red and Yellow	In Phase for Inward Displacement
Black	Transducer Body Ground

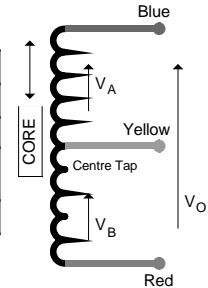

Standard LVDT Gauging Probe Plug Connections

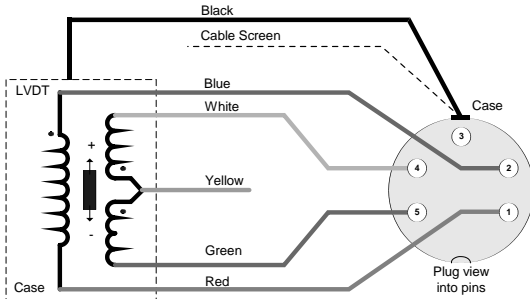

Note 1: + indicates inward movement of the tip.  
 Note 2: The transducer body may be disconnected from the cable screen by cutting the black wire inside the connector

Standard Half-Bridge Gauging Probe Plug Connections

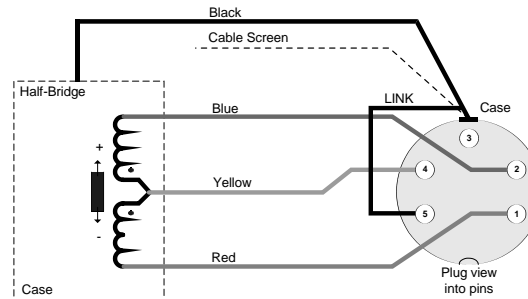

Note 1: + indicates inward movement of the tip.  
 Note 2: The transducer body may be disconnected from the cable screen by cutting the black wire inside the connector

# 4.0: Installation (continued)

---

## 4.5: Connecting the Power Supply

The OD4 requires a dc power supply in the range 10-30 V. A fully regulated supply is not required, but the voltage at the input to the OD4 must remain within specification. Ideally, the 0 V at the power supply should not be connected to earth or the chassis, as this would result in ground loops being formed. The 0 V supply, 0 V signal and case are all internally connected together at the OD4.

## 4.6: Connecting the Signal Out

The output signal may be voltage or current.

### 4.6.1: Voltage Connections

Voltage can easily be monitored using a variety of instrumentation such as voltmeters. Voltage drops along wires contribute to measurement errors, so care must be taken when using long cable lengths (100 m for example). High impedance instruments are more prone to interference.

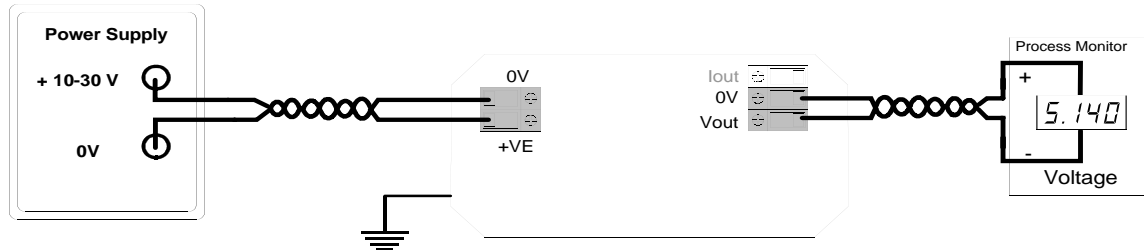

The signal 0 V should always be used as reference. If power supply 0 V is used, then error voltages may be introduced.

# 4.0: Installation (continued)

---

## 4.6.2: Current Connections

Current output requires the use of purposely designed current input instrumentation. Current output is more suitable for transmitting over longer distances because current is not lost due to wiring resistance. Additionally, with a low impedance, a current loop is less likely to pick up noise.

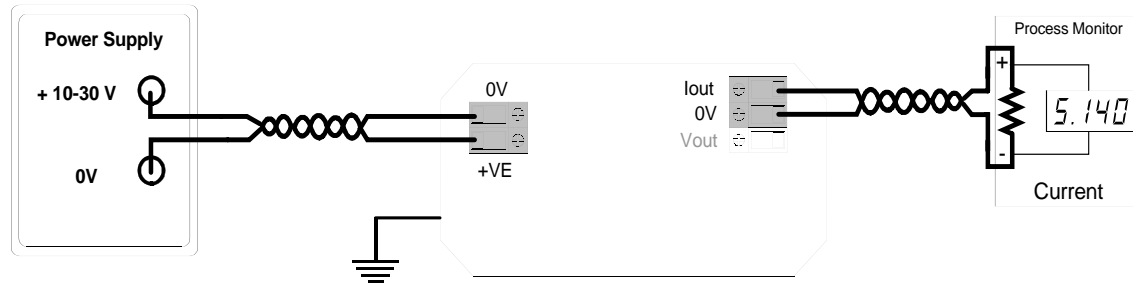

The total loop resistance (resistance of measuring equipment and wiring) must not exceed specification.

Note: The OD4 is not loop-powered, so a power supply must not be used in-line with the current output.

# 4.0: Installation (continued)

## 4.7: Using an EMC Cable Gland

To ensure the cable screen is properly connected to the OD4 case, an EMC cable gland should be used. This is supplied as an optional extra. The diagrams below assume a single 4-way cable is being used. Remove the grommet and fit the cable gland as shown below.

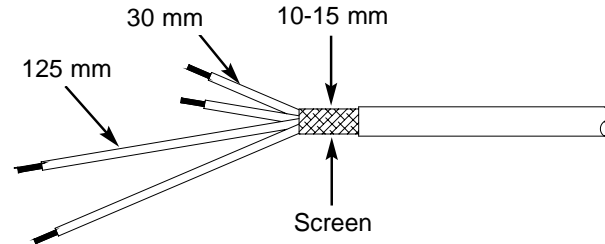
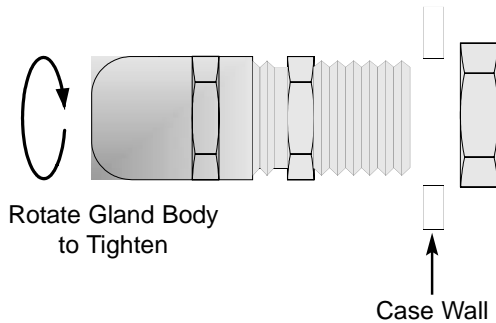

- Prepare cable as shown.
- Slide the Dome nut, sealing ring and plastic insert over cable.
- Fold and roll the screen back over itself to form a lump.
- Push cable into gland body followed by the plastic insert (ensure anti-rotation slots engage), sealing ring and Dome nut.
- Ensure all components are properly seated before tightening the dome nut.

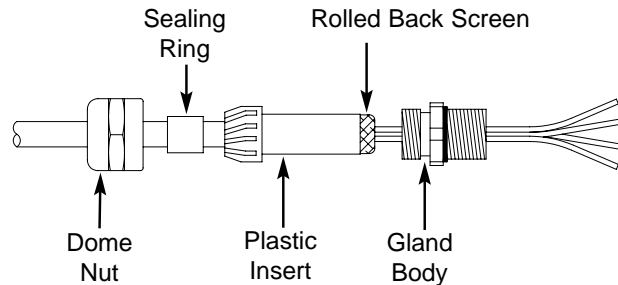

## 5.0: Setting up the Transducer and OD4

---

The OD4 may be set-up with output signals anywhere within a  $\pm 10$  VDC or  $\pm 20$  mA range. Typical outputs are  $\pm 10$  VDC,  $\pm 5$  VDC, 0-10 VDC and 4-20 mA. These procedures apply to voltage and current output.

Voltage and current output are available at the same time, although they cannot be individually adjusted. Either voltage or current should be chosen as the calibration reference.

All outputs use 0 V signal as the signal reference.

A list of standard link settings is available, see section 5.2.



### **CAUTION:**

During installation and adjustment, the top of the enclosure has to be removed for access to user adjustments. At this time, standard ESD handling precautions for electronic equipment should be followed.

# 5.0: Setting up the Transducer and OD4 (continued)

## 5.1: Option Links - Explained

The table below and subsequent diagrams explain the link functions and show the factory setting.

Link	Description	Options	Standard Setting
Course Gain	Sets the basic gain	1 link on Positron 1 to 6	Link ON Position 1
Fine Gain	Adjustment between course gain ranges	Potentiometer Adjustment	Mid Position
Course Offset	Shifts the output by a fixed amount	Link ON -VE or +VE and Link ON 5V or 10V No offset - Link Parked	No offset - Links Parked
Fine Offset	Fine trim around any fixed offset	Potentiometer Adjustment	Mid Position
(7) Null	Used during set-up to null output	ON, OFF	OFF
Freq.	Selects transducer primary frequency	Lo - ON, Hi - Parked	Hi Freq. - Link Parked
Input Resistance	Sets transducer secondary load	100kΩ Parked, 10kΩ - ON, 2kΩ - ON	100KΩ - Link Parked
Polarity (FR)	Enables output signal direction change	2 Links across Forward or Reverse	F Position - 2 Link ON
Input Gain	Input Gain of x1, x2, x4 or divide 2	X1 - Parked, X2 - ON, X4 - ON, DIV2 - ON	Link parked on X2

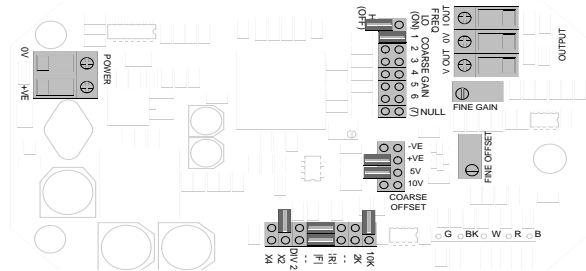
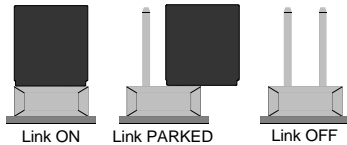

# 5.0: Setting up the Transducer and OD4 (continued) \_\_\_\_\_

## 5.2: Basic Procedure

To set-up the OD4, some basic steps should be followed.

The following steps describe a typical setting procedure and applies to most applications. Other procedures may be used as appropriate.

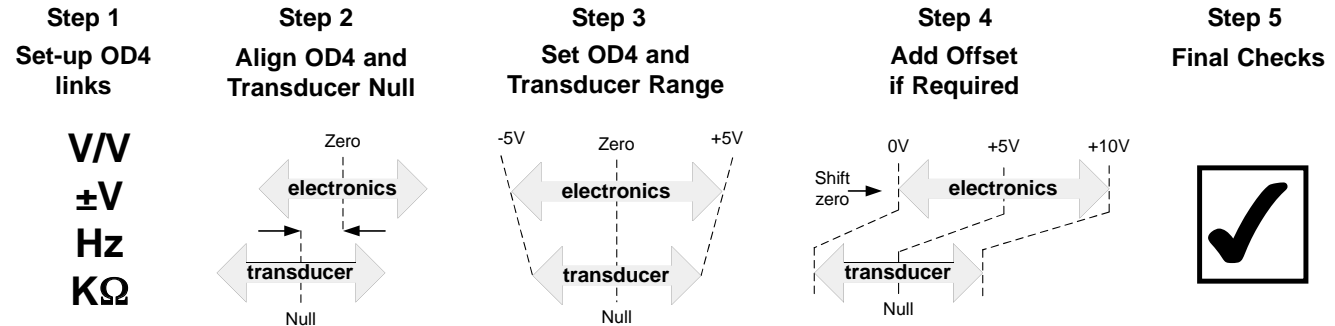

For a bi-polar output i.e.  $\pm 10$  VDC or  $\pm 20$  mA, follow steps 1 to 3.

For a uni-polar output i.e. 0-10 V, 0-20 mA or 4-20 mA, follow steps 1 to 4.

In either case, step 5 (final checks) should be followed on the completion of the set-up.



# 5.0: Setting up the Transducer and OD4 (continued) \_\_\_\_\_

## 5.2: Basic Procedure

### STEP 1 - Set-up OD4 Links

If the transducer characteristics are known, set the frequency and input resistance links as required. A list of standard settings for all Solartron transducers is available from [www.solartronmetrology.com](http://www.solartronmetrology.com). If the transducer characteristics are not known, the standard link settings should be used.

If your transducer is known to be outside of the standard sensitivity range, the X2 or DIV2 links will have to be used. See section 5.3.

### STEP 2 - Align OD4 Null and Transducer Null

Any electrical offset in the OD4 is removed. The transducer position is adjusted so that transducer and OD4 nulls are aligned.

Null the OD4.

1. Put the Gain link on position (7) as shown. This allows any electronics offset in the output stage to be removed.
2. Adjust the Fine Offset control to give as near to zero output as practical.

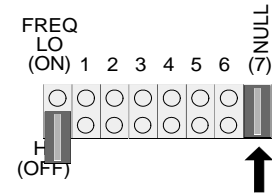

Null the transducer.

1. Replace the Gain link to the original position.
2. Adjust the position of the transducer to give as near to zero output as practical. This is the centre of the mechanical range.

If the transducer cannot be centered for practical reasons an offset will remain within the system. There may be noticeable interaction between Gain and Offset adjustment. This does not prevent the OD4 being set-up. However several iterations may be required when adjusting Gain and Offset. Please contact your supplier if guidance is required.

## 5.0: Setting up the Transducer and OD4 \_\_\_\_\_

# 5.0: Setting up the Transducer and OD4 (continued)

## 5.2: Basic Procedure

### STEP 3 - Setting Bi-Polar Full-scale Output

1. Move the transducer to the position where maximum OD4 output is required.
2. If the polarity of the output is wrong, move the Polarity (FR) links to the R position (see link diagram). Move the transducer back and re-check the zero position. Adjust transducer position as required.

Normal Output Polarity

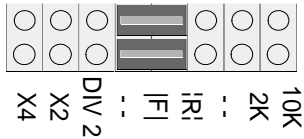

Reverse Output Polarity

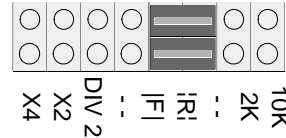

3. Move the RANGE link between 1 and 6 until the OD4 output is near the required value.
4. Adjust the Fine Gain control to give the required output.
5. A bi-polar output has now been set, proceed to step 5. If a uni-polar output is required, proceed to step 4.

Example:  $\pm 10$  VDC is required from a  $\pm 1$  mm transducer. Set the transducer to +1 mm and set the output to 10 V.

If your transducer is known to be outside of the standard sensitivity range, the X2 or DIV2 links will have to be used. See section 5.3.

# 5.0: Setting up the Transducer and OD4 \_\_\_\_\_

## 5.2: Basic Procedure

### STEP 4 - Setting Uni-polar Full-Scale Output (adding an offset)

1. Move the transducer to the null position. OD4 output will be 0 V or 0 mA.
2. Apply offset using the +VE, -VE, 5 V and 10 V links and then adjust the Fine Offset control to set the offset precisely.
3. Perform final checks, step 5.

Example: 0-10 V is required for a  $\pm 1$  mm transducer. Set the transducer to give  $\pm 5$  V over the full range and then, with the transducer at null, add +5 V offset. Adjust the Fine Offset control to give 5 V. When the transducer is moved to the +1 mm position, the output will be +10 V.

Example: 4-20 mA is required for a  $\pm 1$  mm transducer. Set the transducer to give  $\pm 8$  mA over the full range and then, with the transducer at null, add +5 V (approx. 10 mA) offset. Adjust the Fine Offset control to give +12 mA. When the transducer is moved to the +1 mm position, the output will be +20 mA.

### STEP 5 - Final Checks

Ensure that the calibration is correct by moving the transducer across the required mechanical range, checking calibration points. Fine adjustment can be made if required.

It may only be possible to set the output accurately at the two calibration points. This is due to non-linearity within the transducer.

# 5.0: Setting up the Transducer and OD4 (continued) \_\_\_\_\_

## 5.3: Transducer Sensitivity and the X2, X4, DIV2 Link

The OD4 compensates for changes in primary signal amplitude by producing an internal error signal that is the ratio between the primary and secondary signals. If the transducer output signal is too high or too low, errors may occur that can degrade the performance of the OD4 / transducer combination. For these transducers, the X2, X4 or DIV2 input gain link must be used.

For Solartron transducers, consult the list of standard settings available from the downloads section of [www.solartronmetrology.com](http://www.solartronmetrology.com).

### Transducer Full Range Output

In general, transducer sensitivity is quoted as **mV/V/mm**

Where:

**mV** is the output of the transducer

**V** is the primary voltage

**mm** is the mechanical position of the transducer from null (usually mid mechanical range).

To get the transducer Full Range Output, multiply all three together.

### Example:

AX/1.0 sensitivity is 210 mV/V/mm

AX/1.0 range is  $\pm 1$  mm

OD4 primary voltage 3 V

Transducer Full Range Output =  $210 \times 3 \times 1 = 630$  mV (0.63 V)

Set the X2, X4, DIV2 link as shown in the table below.

Transducer Full Range Output	Input Gain Link Setting
400 mV FR to 2500 mV FR	Standard Range - Link Parked on X2
2500 mV FR to 5000 mV FR	High Transducer Output - Link ON DIV2
150 mV FR to 400 mV FR	Low Transducer Output - Link ON X2
55 mV FR to 150 mV FR	Very Low Transducer Output - Link ON X4

5.0: Setting up the Transducer and OD4 \_\_\_\_\_

# 6.0: Half-Bridge only Variant

This is a half-bridge optimised variant of the standard product. The excitation frequency is higher (see specification) and the transducer input connector is wired to accept half-bridge transducers with standard connections.

## 6.1: Connecting the transducer

The 5-pin DIN plug is screwed into the case mounted socket. Transducers not fitted with a plug should be wired to the plug supplied. LVDT transducers cannot be connected to this input.

Standard Half-Bridge Gauging Probe Plug Connections

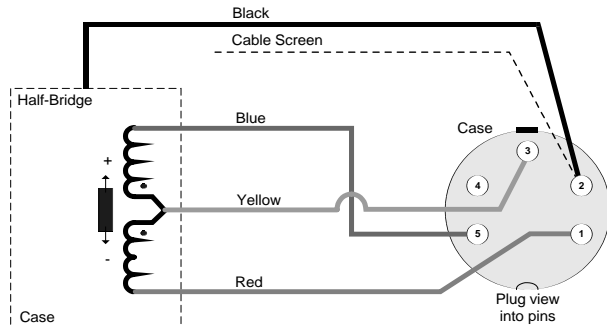

Note 1: + indicates inward movement of the tip.

Note 2: The transducer body may be disconnected from the cable screen by cutting the black wire inside the connector

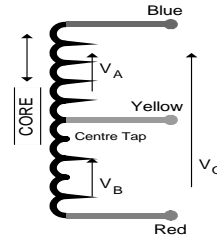

### Half-Bridge Electrical Connections

Red and Blue	Energising
Yellow	Signal
Red and Yellow	In Phase for Inward Displacement
Black	Transducer Body Ground

## 6.2: Setting up the Half-Bridge Transducer

The setting up procedure is the same as LVDT transducers. See section 5. The sensitivity of half-bridge transducers is generally lower than for LVDT types, the x2 and x4 gain position may have to be used. A list of standard link settings for all Solartron Transducers is available from the downloads section of [www.solartronmetrology.com](http://www.solartronmetrology.com).

# 7.0: Specifications

## 7.1: Electrical

Parameter	Value	Comments
<b>Power Supply</b>		
Typical Voltage / Current	24 VDC at 55 mA	
Voltage Range	10 to 30 VDC	
Current Range	140 mA at 10 V to 50 mA at 30 V	
<b>Transducer Excitation</b>		
Energising Voltage	3 Vrms nominal	see note 1
Energising Frequency	2.5 kHz (Lo) or 5 kHz (Hi) nominal 10 kHz (Lo) or 13 kHz (Hi)	link selectable Half-Bridge version only
Energising Current	30 mA max.	
<b>Transducer Signal Input</b>		
Input Signal Range	Standard	400 to 2500 mV FR
	Special	DIV2 2500 to 500 mV FR x2 150 to 400 mV FR x4 55 to 150 mV FR
Input Load Resistance		2, 10, 10 kΩ
Options	Forward and Reverse LVDT Input Half-Bridge Input	link selectable standard special plug wiring or half-bridge version only

# 7.0: Specifications (continued)

## 7.1: Electrical

Parameter	Value	Comments
<b>Signal Output</b>		
Output Voltage Range	up to $\pm 10$ VDC into 1 k $\Omega$	see notes 3 and 4
Output Residual Noise	<1 mVrms	
Output Current	up to $\pm 20$ mA into 150 $\Omega$ load	see note 5
<b>Output Offset</b>		
Coarse	$\pm 5$ VDC (approx 10 mA) fixed	link selectable
	$\pm 10$ VDC (approx 20 mA) fixed	link selectable
Fine	$\pm 2.8$ VDC (approx 5.6 mA)	Variable (adds to fixed offsets)
Temperature Coefficient Gain	<0.01% FRO/ $^{\circ}$ C	
Temperature Coefficient Offset	<0.01% FRO/ $^{\circ}$ C	
Warm-Up	15 minutes recommended	
Linearity	<0.1% FRO	
Bandwidth (-3dB)	500 Hz typical	
<b>Protection (see note 6)</b>		
Power Supply	Reverse connection protected	
Inputs and Outputs	Short circuit protected Transient and ESD Protected	
<b>Certification (see note 7)</b>		
Immunity	BS EN61000-6-2:2001	Immunity for Industrial Environments
Emissions	BS EN61000-6-3:2001	Emission for Residential, commercial and light-industrial environments

# 7.0: Specifications (continued)

---

## 7.2: Mechanical and Connections

Parameter	Value	Comments
Transducer	5-pin circular DIN	
Power Supply	Internal Terminal Block	
Output Signal	Internal Terminal Block	
Enclosure - Size	120 x 65 x 40 mm	Excluding connectors
Weight	300 g (0.66 lbs) approx.	
Material of Case	Die-Cast Zinc Alloy (painted)	

## 7.3: Environmental

Parameter	Value	Comments
Operating Temperature Range	0 - 60°C	
Storage Temperature Range	-20 - 85°C	
IP Rating	IP40	



# 7.0: Specifications (continued)

---

## 7.4: Notes

1. Primary voltage absolute value and drift is not specified. The OD4 uses ratiometric techniques to compensate for primary voltage drift.
2. The way in which the OD4 functions means a special configuration must be used for transducers outside of the standard range. This is selectable by links. The majority of Solartron LVDT transducers are within the standard range. See section 5.
3. OD4 can drive into a 1 k $\Omega$  load but this offers no advantage. 10-100 k $\Omega$  is recommended.
4. Output voltage range can be adjusted as required anywhere within this range by using a combination of gain and offset, for example.  $\pm 10$  VDC,  $\pm 5$  VDC, 0-5 VDC, 0-10 VDC, 4-20 mA.
5. Current output may be used at the same time as voltage output. Calibration of voltage and current cannot be individually adjusted.
6. Protection applies to the product when fully installed according to the user manual. During installation the top of the enclosure has to be removed for access to user adjustments. At this time standard ESD handling precautions for electronic equipment should be followed.
7. The OD4 complies with the toughest electrical emissions and immunity regulations. Compliance requires installation according to the user manual. Compliance does not guarantee performance as the installation environment may be outside of test specification limits. The flexibility of OD4 means it can be installed in a variety of ways according to user requirements. Simple installations with short non-screened cables will meet the lesser light-industrial immunity regulations. Heavy industrial installations, especially with longer cables, will need more careful installation with screened cables.

# Return of Goods

---

Devices returned for service/repair/calibration should be shipped prepaid to your distributor or, if purchased directly from Solartron Metrology, to the relevant Sales Office (see below).

The shipping container should be marked: "**For the Attention of the Returns Department**"

The following information should accompany the device(s):

1. Contact details of company/person returning device, including return shipping instructions.
2. A statement of service required and purchase order.
3. Description of the device fault and the circumstances of the failure, including application environment and length of time in service.
4. Original purchase order number and date of purchase, if known.

Please note: A standard assessment charge is applicable on all non-warranty devices returned for

repair. Customer damage and any device found, upon inspection, to have no fault will be considered non-warranty.

Please contact the Sales Office or Distributor for warranty terms, service options and standard charges.

Adherence to these procedures will expedite handling of the returned device and will prevent unnecessary additional charges for inspection and testing to determine the condition.

Solartron Metrology reserves the right to repair or replace goods returned under warranty.

All repairs are guaranteed for 3 months (unless otherwise stated).

Solartron Metrology reserves the right to make changes without further notice to any products herein to improve reliability, function or design. Solartron Metrology does not assume any liability arising out of the application or use of any product or circuit described herein, neither does it convey any licence under patent rights nor the rights of others.



# SOLARTRON METROLOGY OFFICES

## OFFICES WORLDWIDE - Addresses for Repairs

<b>France</b>	<b>Germany</b>	<b>United Kingdom</b>	<b>U.S.A.</b>
Solartron Metrology Z.I. du Bois Chaland 2, rue du Bois Chaland CE 5611 Lisses Evry Cedex, 91056	Solartron Metrology Wittekindstrasse 12 45470 Mülheim/Ruhr	Solartron Metrology Steyning Way Bognor Regis West Sussex PO22 9ST	Solartron Metrology 10770 Hanover Road Forestville NY 14062
Tel: +33 (0) 1 69 64 47 47 Fax: +33 (0) 1 69 64 47 49 france@solartronmetrology.com	Tel: +49 (0) 208 31026 Fax: +49 (0) 208 31441 vietrieb@solartronmetrology.com	Tel: +44 (0) 1243 833333 Fax: +44 (0) 1243 833332 sales@solartronmetrology.com	Tel: +1 (716) 965 4100 Fax: +1 (716) 965 4144 usatech@solartronmetrology.com

[www.solartronmetrology.com](http://www.solartronmetrology.com)

**Solartron Metrology Ltd. is a subsidiary of The Roxboro Group Plc.**

