

Traulsen & Co., Inc.



Quality Refrigeration

OWNER'S MANUAL

Instructions for the installation, operation,
and maintenance of all Compact Undercounter
and Prep Table Models:

UHT27	ULT27	UPT276	UPT488	UPT6012
UHT48	ULT48	UPT279	UPT4812	UPT6018
UHT60	ULT60		UPT4818	UPT6024

This Traulsen unit is built to our highest quality standards. We build our refrigerators, freezers and heated cabinets this way as a matter of pride. This philosophy has made Traulsen the leader in commercial refrigeration since 1938. We thank you for your choice and confidence in Traulsen equipment and we know you will receive many years of utility from this equipment.

All Traulsen units are placed on a permanent record file with the service department. In the event of any future questions you may have, please refer to the model and serial number found on the name tag affixed to the unit. Should you need service, however, call us on our toll free number, 800-825-8220 between 7:30 am and 4:30 pm CST, Monday thru Friday. It is our pleasure to help and assist you in every possible way.

INSTALLER

COMPLETE THE FOLLOWING INFORMATION PRIOR TO UNIT INSTALLATION

INITIAL START DATE: _____ SERIAL NO. _____





MODEL TYPE: _____

COMPANY/INDIVIDUAL NAME: _____

INSTALLER: _____

TABLE OF CONTENTS

I. THE SERIAL TAG	Page 1	V. CARE & MAINTENANCE	
II. RECEIPT INSPECTION	Page 2	a-Cleaning The Exterior	Page 7
III. INSTALLATION		b-Cleaning The Interior	Page 7
a-Location	Page 2	c-Cleaning The Condenser Coil	Page 7
b-Packaging	Page 2	d-Condensate Removal System Care	Page 7
c-Installing Legs or Casters	Page 2/3	e-Cleaning The Interior	Page 7
d-Installing Shelf Clips	Page 3	VI. MISC. OPERATIONS	
e-Cord & Plug	Page 3	a-Rehinging The Door	Page 8
f-Power Supply	Page 3	b-Preparing For Extended Shut Down	Page 8
g-Wiring Diagram	Page 3	c-Adjusting The Door	Page 8
h-Clearance	Page 3	d-Door Gasket Replacement	Page 8
i-Optional Utility Base	Page 3/4	VII. OTHER	
j-Optional Stacking Kit	Page 5	a-Service Information	Page 9
k-Sandwich Prep Top Assembly	Page 5	b-Spare Parts	Page 9
l-Installing The Stainless Steel Top	Page 6	c-Warranty Registration	Page 9
IV. OPERATION		VIII. TROUBLESHOOTING GUIDE	Page 10
a-Prestart Checks	Page 6	IX. PARTS LIST	Page 11
b-Temperature Control	Page 6	X. WARRANTY INFORMATION	Page 13
c-Defrost Control	Page 6/7	XI. INDEX	Page 14
d-Refrigerating Product	Page 7		
e-Pans & Divider Bars	Page 7		

MODEL NO	SN NO	
ML	MAX OPERATING AMBEINT	
VOLTS	HZ	PH
		TOTAL AMPS
COMMERCIAL REFRIGERATOR AND/OR FREEZER		
		
		
MADE IN USA		

I. THE SERIAL TAG

The serial tag is a permanently affixed sticker on which is recorded vital electrical and refrigeration data about your Traulsen product, as well as the model and serial number. This tag is located on the left interior wall on all compact undercounter refrigerator, freezer and prep table models.

READING THE SERIAL TAG

- Serial = The permanent ID# of your Traulsen
- Model = The model # of your Traulsen
- Volts = Voltage
- Hz = Cycle
- PH = Phase
- Total Current = Maximum amp draw
- Minimum Circuit = Minimum circuit ampacity
- Lights = Light wattage
- Heaters = Heater amperage (Hot Food units only)
- Refrigerant = Refrigerant type used
- Design Pressure = High & low side operating pressures and refrigerant charge
- Agency Labels = Designates agency listings

II. RECEIPT INSPECTION

All Traulsen products are factory tested for performance and are free from defects when shipped. The utmost care has been taken in crating this product to protect against damage in transit. All interior fittings have been carefully secured and the legs or casters are boxed and strapped inside to prevent damage.

You should carefully inspect your Traulsen unit for damage during delivery. If damage is detected, you should save all the crating materials and make note on the carrier's Bill Of Lading describing this. A freight claim should be filed immediately. If damage is subsequently noted during or immediately after installation, contact the respective carrier and file a freight claim. Under no condition may a damaged unit be returned to Traulsen & Co. without first obtaining written permission (return authorization).

III. INSTALLATION

III. a - LOCATION:

Select a proper location for your Traulsen unit, away from extreme heat or cold. Condenser performance is dependent on adequate ventilation for cooling purposes. Adequate clearance **MUST** be provided for the ventilator locations underneath. There are no clearance requirements for sides, rear, or top.

NOTE: Do not install the cabinet without legs, casters or front ventilated utility base.

III. b - PACKAGING:

All Traulsen units are shipped from the factory bolted to a sturdy wooden pallet and packaged in a durable cardboard container. The carton is attached to the wooden skid with the use of large staples. These should first be removed to avoid scratching the unit when lifting off the crate.

To remove the wooden pallet, first if at all possible, we suggest that the cabinet remain bolted to the pallet during all transportation to the point of final installation. The bolts can then be removed with a 5/8" socket wrench by tipping or otherwise raising the unit to allow access to them. Avoid laying the unit on its front, side or back for removal of the pallet.

NOTE: Traulsen does not recommend laying the unit down on its front, side or back. However, if you must please be certain to allow the unit to remain in an upright position afterwards for 24 hours before plugging it in so that the compressor oils and refrigerant may settle.

III. c - INSTALLING LEGS OR CASTERS:

6" high legs are supplied standard for all Traulsen compact undercounter units. These are shipped from

III. INSTALLATION (continued)

III. c - INSTALLING LEGS OR CASTERS (cont'd): the factory inside a cardboard box which is secured inside the cabinet. Casters in lieu of legs are supplied as an optional accessory for all compact undercounter models. The casters are "stem" type, and do not require the use of any bolts. When ordered, casters are shipped in a separate box.

WARNING: THE CABINET MUST BE BLOCKED AND STABLE BEFORE INSTALLING LEGS OR CASTERS.

Raise up and block the cabinet a minimum of 7" from the floor and thread the legs into the threaded holes on the bottom of the cabinet (see figure 1).

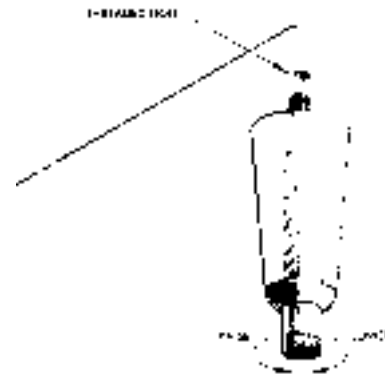
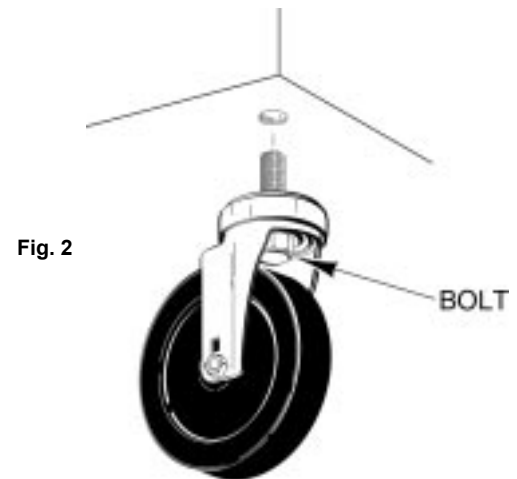

Fig. 1

Thread optional casters into the threaded holes on the bottom of the cabinet in the same way (see figure 2). Casters with brake should be installed at the front.



Level the cabinet using a level or pan of water in the bottom of the cabinet. On units with legs, turn the adjustable feet in or out to level the cabinet side-to-side and front-to-back. Units with casters should be placed on level floors.

III. INSTALLATION (continued)

III. c - **INSTALLING LEGS OR CASTERS** (cont'd):

Please note that Traulsen units are not designed to be moved while on legs. If the unit requires moving, a pallet jack or forklift should be used to prevent damage.

III. d - **SHELF CLIPS**:

Shelves and shelf clips are shipped with the unit. For each shelf, insert four (4) shelf clips into the pilaster slots at the same height (Fig. 3). The shelf clips have a small projection on top which holds the shelf in position and prevents it from slipping forwards. After installing shelf clips on pilasters, place shelves on clips.

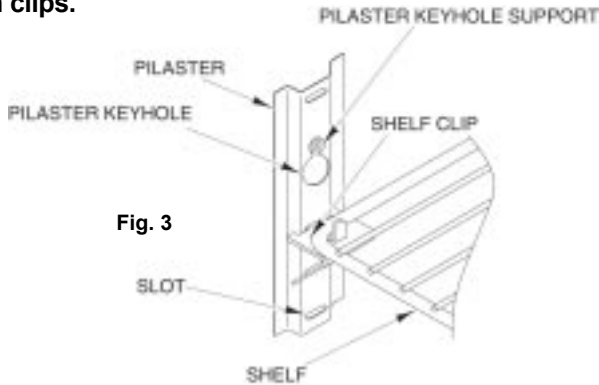

III. e - **CORD & PLUG**:

All UHT, ULT & UPT models are supplied with a cord & plug attached. It is shipped coiled at the bottom of the cabinet, secured by a nylon strip. For your safety and protection, all units supplied with a cord and plug include a special three-prong grounding plug on the service cord. Select only a dedicated electrical outlet with grounding plug for power source. NOTE: Do not under any circumstances, cut or remove the round grounding prong from the plug, or use an extension cord.

III. f - **POWER SUPPLY**:

The supply voltage should be checked prior to connection to be certain that proper voltage for the cabinet wiring is available (refer to the serial tag to determine correct unit voltage). Make connections in accordance with local electrical codes. Use qualified electricians.

Use of a separate, dedicated circuit is required. Size wiring to handle indicated load and provide necessary overcurrent protector in circuit (see amperage requirements on the unit's serial tag).

III. g - **WIRING DIAGRAM**:

Refer to the wiring diagram for any service work performed on the unit. Should you require one, please contact Traulsen Service at (800) 825-8220, and provide the model and serial number of the unit involved.

III. h - **CLEARANCE**:

It is important for the proper operation and longevity of your Traulsen unit that it have adequate provisions underneath for air supply to the compressor. There are no clearance requirements for the sides, rear or top.

NOTE: Do not install the cabinet without legs, casters or a front ventilated utility base.

III. i - **OPTIONAL UTILITY BASE**:

An optional utility base is available, in lieu of legs or casters, for models UHT27, ULT27, UPT276 & UPT279 only. To install this, follow the directions below see (figure 4):

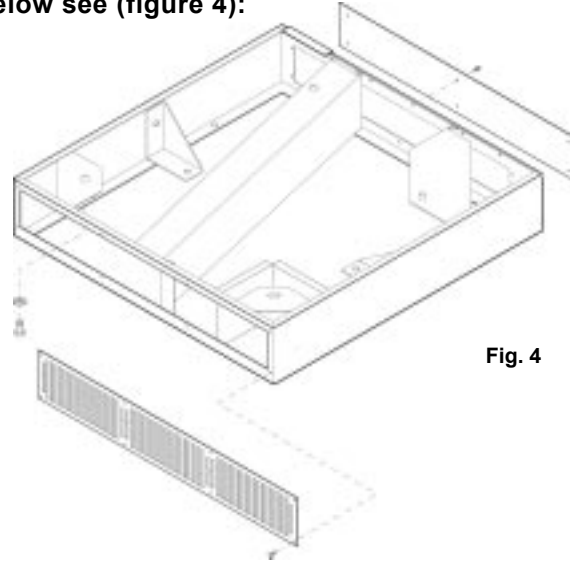

1. Place utility base in final installed location. NOTE: The front of the utility base must be oriented towards the front. Fastener locations are provided for anchoring utility base to floor, if desired; fasteners are not provided.
2. Place unit on top of utility base so holes underneath are aligned. The plug cord must be routed from the bottom right rear corner of the unit through a slotted hole in the utility base. Assemble the strain relief (provided) around the electric cord and route it through the slotted hole in the utility base.

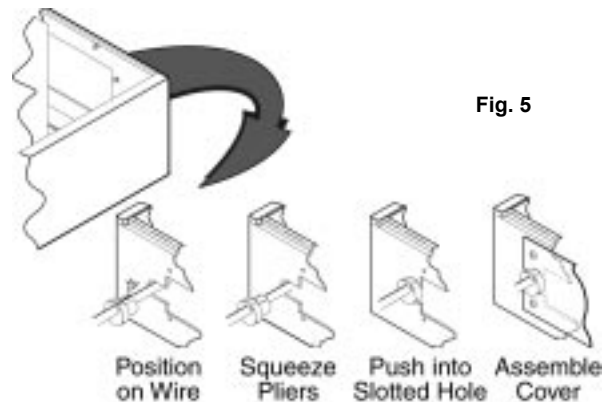

III. INSTALLATION (continued)

III. i - OPTIONAL UTILITY BASE (cont'd):

3. Assemble four 1/2 – 13 bolts and lockwashers through holes in utility base and into threaded holes in bottom of unit where legs or casters would be installed.
4. Place rear cover on back of utility base so D-slot captures the groove of the strain relief. Attach rear cover with six 8 – 18 self-tapping screws. If floor receptacle is provided underneath utility base for unit to plug into, strain relief will not be used and rear cover should be installed up-side-down so D-slot is covered.
5. Install front grill on front of stacking base with eight 8 – 18 self-tapping screws.

If your unit comes with a utility base, we recommend securing the base to the floor. Place the unit in its final installed position, then apply a bead of NSF approved silicone sealant around the bottom.

III. j - OPTIONAL STACKING KIT:

Models UHT27 and ULT27 only have the option of a stacking kit, in which no more than two (2) units can be stacked one on top of the other.

1. Install legs, casters or utility base on bottom unit following instructions elsewhere in this manual. Place bottom unit near final installed location leaving access to rear for further assembly.
2. Place stacking base on top of bottom unit. NOTE: The front of the stacking base must be oriented towards the front.
3. Assemble two 1/4 – 20 x 5/8" screws through front mounting flange of stacking base into the threaded holes in the front of the top edge of the bottom unit. Assemble five 10 – 16 x 1/2" screws through rear flange of the stacking base into the upper rear of bottom unit.
4. Place upper unit on top of stacking base so holes underneath are aligned.
5. Assemble four 1/2 – 13 bolts and lockwashers through holes in stacking base into threaded holes in bottom of upper unit where legs or casters would be installed if unit were to sit directly on the floor.
6. The plug cord must be routed from the bottom right rear corner of the upper unit through a slotted hole in the stacking base. Assemble the strain relief (provided) around the electric cord and route it through the slotted hole in the stacking base.
7. Place rear cover on back of stacking base so the D-slot captures the groove of the strain relief. Attach rear cover with six 8 – 18 self-tapping screws.

III. j - OPTIONAL STACKING KIT (cont'd):

8. Install front grill on front of stacking base with eight 8 – 18 self-tapping screws.

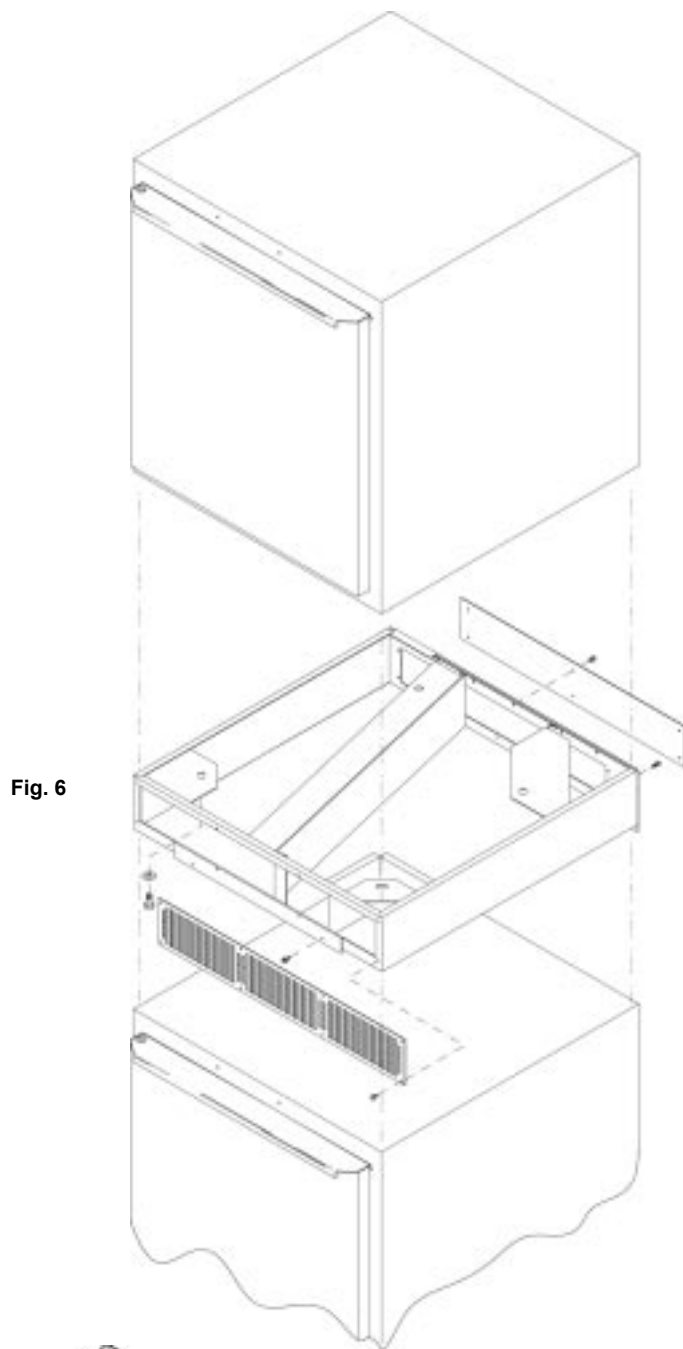

Fig. 6

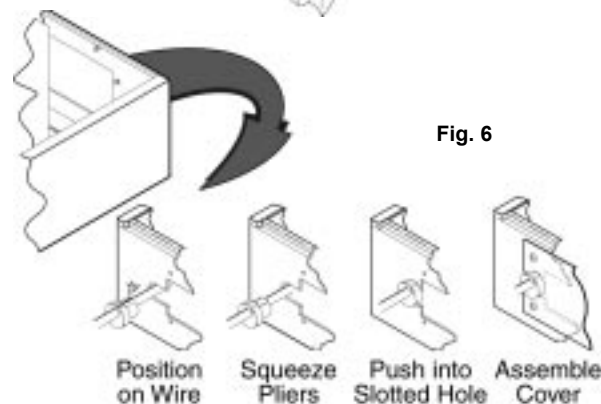

Fig. 6

III. INSTALLATION (continued)

III. k - SANDWICH PREP TOP ASSEMBLY:

On sandwich prep tables (see figure 8), the top shelf, cutting board, and cover may require assembly at the site.

1. Place the shelf on top of the rear of the unit. Secure by screwing 4 threaded pins through base of shelf and top of unit (see figure 9).
2. Install cutting board support. Secure with 2 threaded pins and 2 bolts per flange (see figure 9) (wider units may be equipped with an additional third pin in the center).
3. Assemble cutting board to cutting board support (pins holding cutting board support fit through holes in cutting board when properly aligned, see figure 9).
4. To install cover, flex cover so side pins fit in holes at lower front corners of shelf (see figure 9). Cover pivots up to open.

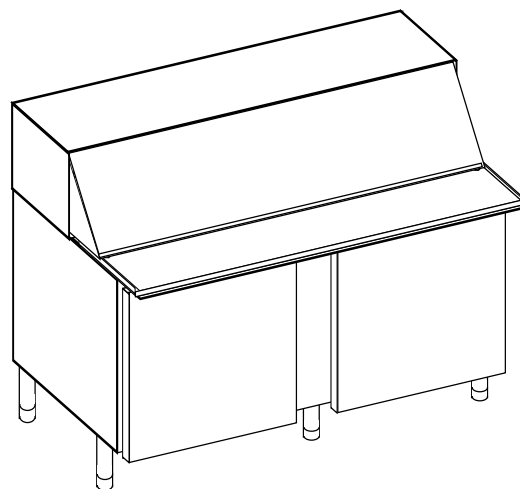

Fig. 8

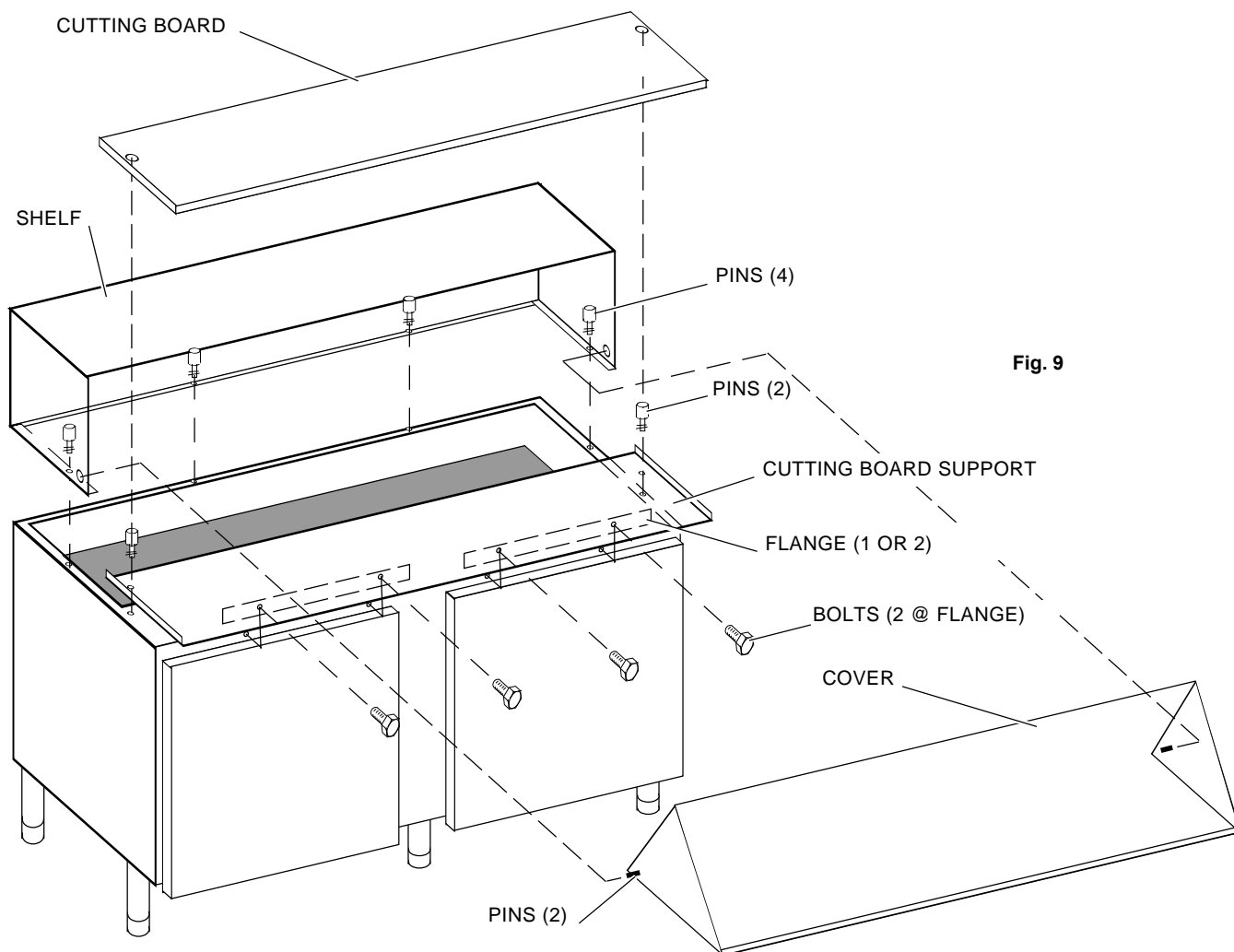

Fig. 9

III. INSTALLATION (continued)

III. I - INSTALLING THE STAINLESS STEEL TOP:

All 27", 48" and 60" wide compact undercounter models can be supplied with an optional stainless steel top. This must be installed on-site, to do so please follow the directions below (see figure 10):

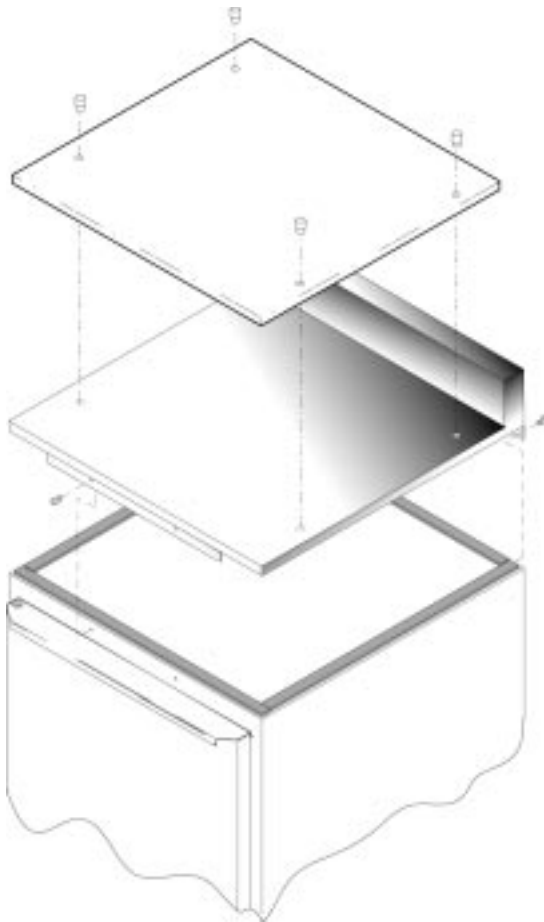

Fig. 10

1. Peel off backing and install foam tape (provided) around entire perimeter of the top of the unit.
2. A flange is assembled underneath at the front of the countertop. This flange has two screw holes. Screw the two 1/4 – 20 x 5/8" screws (provided) through the holes in this front flange into the threaded holes in the front of the top edge of the unit.
3. Using the five 10 – 16 x 1/2" screws provided, screw the bottom of the rear cover plate to the upper rear of the cabinet.
4. If the optional polyethylene cutting board top is provided, there are four threaded pins which screw into the four threaded holes in the worktop. The four holes in the polyethylene cutting board top fit around the heads of the four pins.

IV. OPERATION

IV. a - PRESTART CHECKS:

The compressor must float freely before connecting to electrical power. The compressor motor is provided with rubber vibration isolator mounts (no springs). No bolts need to be loosened. Check all exposed refrigeration lines to make sure they are not dented or kinked. Check for tubing shifts due to shipping that would cause operating noise, wear, or leaks. Check that condenser fan rotates freely.

The refrigeration system should be checked for proper operation before product is stored in the cabinet.

IV. b - TEMPERATURE CONTROL:

The temperature is set at the factory but local conditions may necessitate slight adjustment.

The temperature control shown in figure 11 is located on the right side of the evaporator housing. To adjust, turn the adjustment screw with a screwdriver a small amount at a time; turning clockwise lowers the temperature. An "OFF" position is fully counterclockwise and interrupts power to the compressor and condenser fan only, not the entire refrigerator.

Fig. 11
Thermostat - All
Current Models

F
R
O
N
T
←

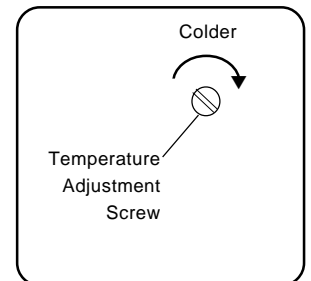

IV. c - DEFROST CONTROL:

Frozen food storage cabinets are equipped with a defrost timer (figure 12) that provides a 20-minute defrost cycle every 6 hours (four defrost cycles per day).

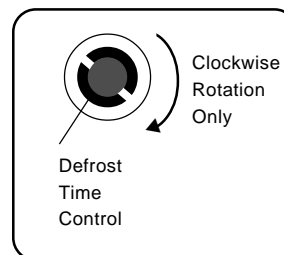

Fig. 12
Defrost Timer
Models ULT27, ULT48 & ULT60 Only

This control can be adjusted to set when the next defrost cycle will start. To adjust the defrost time control, use a coin on the outside slot in the rim of the timer and turn clockwise until the compressor turns off. Continue turning coin clockwise until the

IV. OPERATION

IV. c - DEFROST CONTROL (CONT'D):

compressor restarts. The next defrost cycle will start in about 5 hours 40 minutes. On models ULT27, ULT48 and ULT60, the defrost time control is located on the right side of the evaporator housing, behind the temperature control adjustment screw. On earlier models ULT48 and ULT60, the defrost time control was accessed through a small round opening on the outside rear of the unit.

IV. d - REFRIGERATING PRODUCT:

A Thermometer (figure 13) is provided inside all UHT, ULT & UPT models. Allow the cabinet to reach normal operating temperature before loading.



Fig. 13

UHT, ULT & UPT Series will satisfactorily refrigerate an assorted load of food items. Allow space between articles to permit free air circulation. Do not overload at any one time with warm food products and expect immediate results. A certain amount of time is required to remove heat from items before operating temperatures can be attained. The system is designed for storage of refrigerated or frozen product.

Opening the door will increase the temperature in the cabinet and will require a certain amount of time to recover. Also, after peak service periods or after warm product is loaded, the refrigerator will require a certain amount of time for the temperature to return to the normal operating range.

IV. e - PANS & DIVIDER BARS:

Sandwich Prep models are provided with 1/6 size plastic pans and metal divider bars. When 18 one-sixth size pans are ordered, four standard and one wide pan divider / supports are provided to achieve appropriate pan separation. When 24 one-sixth size pans are ordered, six standard and one wide pan divider bars are provided to achieve appropriate pan separation. All other arrangements use all standard width pan divider bars.

V. CARE AND MAINTENANCE:

V. a - CLEANING THE EXTERIOR:

Exterior stainless steel should be cleaned with warm water, mild soap and a soft cloth. Apply with a dampened cloth and wipe in the direction of the metal grain.

Avoid the use of strong detergents and gritty, abrasive cleaners as they may tend to mar and scratch the surface. Do NOT use cleansers containing chlorine, this may promote corrosion of the stainless steel.

Care should also be taken to avoid splashing the unit with water, containing chlorinated cleansers, when mopping the floor around the unit.

For stubborn odor spills, use baking soda and water (mixed to a 1 TBSP baking soda to 1 pint water ratio).

V. b - CLEANING THE INTERIOR:

For cleaning the interior, the use of baking soda as described in section "V. a" is recommended. Use on breaker strips as well as door gaskets. All interior fittings are removable without tools to facilitate cleaning.

V. c - CLEANING THE CONDENSER COIL:

Check the condenser coil periodically. The operating environment will affect the required frequency of cleaning. Air must be able to freely circulate through the condenser. This surface must be kept free of dirt and grease for proper system operation. Remove the lower rear panel on the rear of the equipment cabinet. Carefully clean dirt and lint from the condenser coil using a vacuum cleaner or soft brush; do not use a wire brush. Replace the lower rear panel. Reconnect electrical power supply.

V. d - CONDENSATE REMOVAL SYSTEM CARE:

The evaporator coil, condensate loop and condensate pan, when needed, can all be flushed with fresh water by a qualified service technician. This should be part of any routine maintenance program and can prolong the life of the equipment.

Condensate removal is provided by evaporation at the lower rear portion of the equipment cabinet and does not need a drain. Periodic cleaning of the condensate removal box may be needed. To access the condensate removal box, remove the lower panel at the rear of the equipment cabinet. Clean the condensate removal box by wiping it out with a clean damp cloth, using care with the condensate loop inside. Replace the lower rear panel. Reconnect electrical power supply.

WARNING: DISCONNECT ELECTRICAL POWER SUPPLY BEFORE CLEANING ANY PARTS OF THE UNIT.

VI. MISC. OPERATIONS

VI. a - REHINGING THE DOOR:

The door(s) on all UHT, ULT & UPT models can be easily rehung in the field. To begin, open the door to its maximum position. Support the non-hinged end of the door so minimum movement occurs when the bolts from the lower hinge plate are removed. Remove the lower hinge plate and then the door from the top hinge bracket. The hinge plate pin and plastic bushing will remain in the top hinge plate (see figure 14).

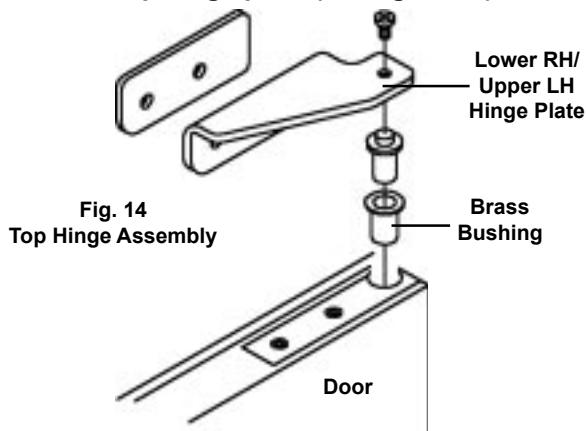

Lay the door down on a padded flat surface while being careful not to allow the lower hinge plate and mechanism stem to slide out the bottom of the door.

NOTE: The lower hinge plate is under spring tension (see figure 15). Grasp the lower hinge plate. While keeping a firm grip on the plate, carefully slide it out the bottom of the door just far enough to allow the plate to rotate a full 360°. Unwind the tension of the spring by carefully allowing the hinge plate to rotate a full 360° several times.

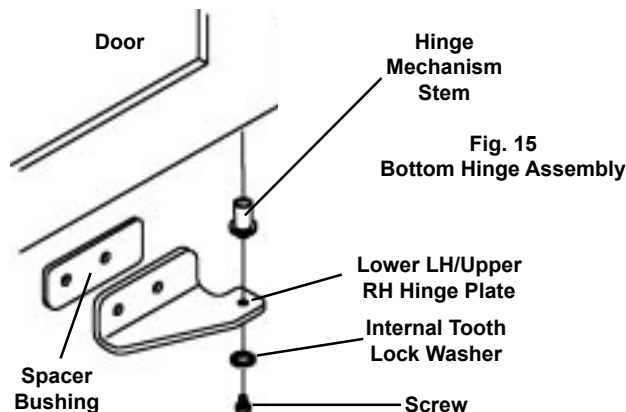

Slide the hinge plate and hinge mechanism stem out the bottom of the door.

NOTE: Remove the brass bushing from the bottom of the door only if spring replacement is necessary. Both the spring and bushing will need to be new parts.

NOTE: When installing, make sure the lower hinge plate and hinge mechanism stem are rotated no more than six (6) full turns while applying tension to the spring.

VI. a - REHINGING THE DOOR (cont'd):

To reinstall the door, position the lower hinge plate into the position of being open 90° to the cabinet. Place the top hinge plate pin in the hole in the top of the door and support the other end of the door for minimal movement.

Start the bolts in the lower hinge plate and tighten the bolts enough to hold the door in place. Remove the block from under the end of the door. Adjust the door as outlined in section VI. c.

VI. b - PREPARING FOR EXTENDED SHUT DOWN:

If the refrigerator is not to be used for an extended period of time, disconnect the electrical power supply and open the doors. As soon as the cabinet has warmed up to room temperature, wipe out the interior. Leave the doors open and check again to make sure that no moisture has collected on any parts. To restart refrigerator, follow instructions under PRESTART CHECKS and OPERATION.

VI. c - ADJUSTING THE DOOR:

Occasionally the door(s) may require alignment adjustment. To do so, first open the door and loosen the hinge plate screws enough to move the hinges if desired, but the door is held in place. Center the door in the opening. Next level the top hinge plate and tighten the screws. Finally, level the lower hinge plate and tighten the screws (see figure 16).

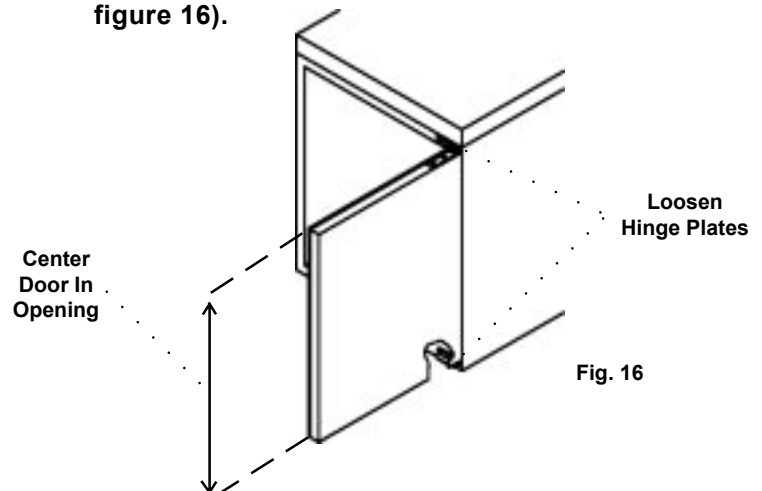

VI. d - DOOR GASKET(S) REPLACEMENT:

Remove the old gasket by pulling it out from the gasket retainer. Next, install the four corners of the new gasket by pushing straight in on the gasket until it is hooked behind the gasket retainer. Be careful not to stretch the gasket as it will not return to its original length. Starting at the center of one edge, push the door gasket straight in until it is hooked behind the gasket retainer. Proceeding from this point out to the corners, continue pushing the door gasket straight into the gasket retainer. Proceed doing the same to each of the remaining edges until the gasket is completely installed.

VII. OTHER

VII. a - SERVICE INFORMATION:

Before calling for service, please check the following:

- Is the electrical cord plugged in?
- Is the fuse OK or circuit breaker on?
- Is the power switch "ON"?

If after checking the above items and the unit is still not operating properly, please contact an authorized Traulsen service agent. A complete list of authorized service agents was provided along with your Traulsen unit. If you cannot locate this, you may also obtain the name of a service agent from the Tech Service page of our website: www.traulsen.com.

If service is not satisfactory, please contact our in-house service department at:

Traulsen & Co., Inc.
4401 Blue Mound Road
Fort Worth, TX 76106
(800) 825-8220

Traulsen & Co., Inc. reserves the right to change specifications or discontinue models without notice.

VII. b - SPARE PARTS:

Spare or replacement parts may be obtained through a parts supplier or one of our authorized service agents. A complete list of authorized service agents accompanies this manual and is also posted on our company's official website @ www.traulsen.com.

VII. c - WARRANTY REGISTRATION:

For your convenience, the warranties on your new Traulsen unit may be registered with us by one of two methods. Completing the enclosed warranty card (shipped with the unit), or by filling out the on-line warranty registration form located on the Technical Service page of our website (www.traulsen.com).

VIII. TROUBLESHOOTING GUIDE

FIND YOUR PROBLEM HERE	REMEDY
1. Condensing unit fails to start.	<ul style="list-style-type: none"> a. Check if cord & plug has been disconnected. b. Check thermostat temperature setting.
2. Condensing unit operates for prolonged periods or continuously.	<ul style="list-style-type: none"> a. Are doors closing properly? b. Dirty condenser or filter. Clean properly. c. Evaporator coil iced. Needs to defrost. d. Shortage of refrigerant, call service.
3. Food compartment is too warm.	<ul style="list-style-type: none"> a. Check door(s) and gasket(s) for proper seal b. Perhaps a large quantity of warm food has recently been added or the door was kept open for a long period of time, in both cases, allow adequate time for the cabinet to recover its normal operating temperature. c. Thermostat setting too high, readjust per instructions on page 6. d. Check that condensing coil is clean.
4. Food compartment is too cold.	<ul style="list-style-type: none"> a. Perhaps a large quantity of very cold or frozen food has recently been added. Allow adequate time for the cabinet to recover its normal operating temperature. b. Adjust the thermostat to a warmer setting, see page 6.
5. Condensation on the exterior surface.	<ul style="list-style-type: none"> a. Check door alignment and gaskets for proper seal. b. Condensation on the exterior surface of the unit is perfectly normal during periods of high humidity.
6. Compressor hums but does not start.	<ul style="list-style-type: none"> a. Call for service.

IX. PARTS LIST

PART NAME	PART #	DESCRIPTION
Back, Finished	SER-60310-00	Optional Stainless Steel Finished Back For 27" Wide Models Only
Casters, 6" High	SER-60275-00	Optional Set of Four (4) 6" High Casters For All 27" Wide Models
Casters, 6" High	SER-60276-00	Optional Set of Six (6) 6" High Casters For All 48" & 60" Wide Models
Casters, 3-1/2" High	SER-60277-00	Optional Set of Four (4) 3-1/2" High Caster For All 27" Models
Casters, 4" High	SER-60308-00	Optional Set of Four (4) 4" High Caster For All 27" Models
Hinge Plate	SER-60248-00	Replacement Hinge Plate (upper left hand/lower right hand) For All Models
Hinge Plate	SER-60249-00	Replacement Hinge Plate (upper right hand/lower left hand) For All Models
Shelf, 27" Models	SER-60270-00	Additional or Replacement Shelf For 27" Wide Models
Shelf, Upper	SER-60273-00	Additional or Replacement Upper Shelf For 48" Wide Models
Shelf, Lower	SER-60274-00	Additional or Replacement Lower Shelf For 48" Wide Models
Shelf, Upper	SER-60272-00	Additional or Replacement Upper Shelf For 60" Wide Models
Shelf, Lower	SER-60271-00	Additional or Replacement Lower Shelf For 60" Wide Models
Shelf Clip	SER-60269-00	Additional or Replacement Shelf Clip For All Models (four required per shelf)
Stacking Kit	SER-60311-00	Optional Stacking Kit For 27" Wide UHT & ULT Models Only
Thermometer	SER-60268-00	Replacement Thermometer For All Models
Top, 27" Models	SER-60278-00	Optional Backsplash Top For 27" Wide Compact Refrigerator & Freezer Models
Top, 48" Models	SER-60279-00	Optional Backsplash Top For 48" Wide Compact Refrigerator & Freezer Models
Top, 60" Models	SER-60280-00	Optional Backsplash Top For 60" Wide Compact Refrigerator & Freezer Models
Utility Base, 6" High	SER-60309-00	Optional 6" High Utility Base For 27" Wide Models Only

X. WARRANTY INFORMATION

STANDARD DOMESTIC WARRANTY

TRAULSEN & CO., INC. warrants new equipment to the original purchaser, when installed within the United States against defective material and workmanship for one (1) year from the date of original installation. Under this warranty, **TRAULSEN & CO., INC.** will repair or replace, at its option, including service and labor, all parts found to be defective and subject to this warranty. The compressor part is warranted for an additional four (4) years. During this period **TRAULSEN & CO., INC.** will supply replacement compressor(s) if deemed defective, however, all installation, recharging and repair costs will remain the responsibility of the owner.

This warranty does not apply to damage resulting from fire, water, burglary, accident, abuse, misuse, transit, acts of God, attempted repairs, improper installation by unauthorized persons, and will not apply to food loss.

THERE ARE NO ORAL, STATUTORY OR IMPLIED WARRANTIES APPLICABLE TO TRAULSEN, INCLUDING BUT NOT LIMITED TO, ANY IMPLIED WARRANTY OF MERCHANTABILITY OR FITNESS FOR ANY PARTICULAR PURPOSE WHICH EXTEND BEYOND THE DESCRIPTION ON THE FACE HEREOF. TRAULSEN SHALL HAVE NO OBLIGATION OR LIABILITY FOR CONSEQUENTIAL OR SPECIAL DAMAGES, GROWING OUT OF OR WITH RESPECT TO THE EQUIPMENT OR ITS SALE, OPERATION OR USE, AND TRAULSEN NEITHER ASSUMES NOR AUTHORIZES ANYONE ELSE TO ASSUME FOR IT ANY OBLIGATION OR LIABILITY IN CONNECTION WITH THE EQUIPMENT OR ITS SALE, OPERATION OR USE OTHER THAN AS STATED HEREIN.

INTERNATIONAL COMMERCIAL WARRANTY

(for Canadian warranties see domestic US warranty)

TRAULSEN & CO., INC. warrants to the original purchaser the Refrigeration Equipment manufactured and sold by it to be free from defects in material and workmanship under normal use and service for a period of one (1) year from date of shipment. Under this warranty, **TRAULSEN & CO., INC.** will reimburse the purchaser for the replacement of any part of said equipment (excluding dryers & refrigerant gas) which then proves to be defective. This warranty is void if said equipment or any part thereof has been subject to misuse, damage in transit, accident, negligence or alteration.

TRAULSEN'S standard warranty does not apply to Export Sales. Rather, for a period of one (1) year from date of original installation not to exceed Fifteen (15) months from date of shipment from factory, TRAULSEN:

will replace, F.O.B. factory, any defective parts normally subject to warranty.

will not cover the cost of packing, freight or labor such costs being the sole responsibility of the dealer.

THIS WARRANTY IS IN LIEU OF ALL OTHER WARRANTIES EITHER EXPRESSED OR IMPLIED AND CONSTITUTES TRAULSEN'S FULL OBLIGATION AND LIABILITY. WARRANTIES NOT AVAILABLE ON REMOTE MODELS.

XI. INDEX

<u>A</u>		<u>R</u>	
<u>B</u>		Rehinging The Door	8
<u>C</u>		Return Authorization	2
Cleaning, The Exterior	7	<u>S</u>	
Cleaning, The Interior	7	Sealant, Silicone	4
Casters	2, 3	Serial Tag	1
Condensate Evaporator	7	Shelf Clips	3
Cord & Plug	3	Shelves	3
Condenser Coil, Cleaning	7	Stacking Kit, Installing	4
Condenser, Performance	2	Stainless Steel Top, Installing	6
Clearance	2, 3	<u>T</u>	
Condensate Loop	7	Thermostat	7
Cutting Board	5	<u>U</u>	
<u>D</u>		Utility Base	4
Defrost Control	6	<u>V</u>	
Divider Bars	7	<u>W</u>	
<u>E</u>		Warranty	9
Evaporator Coil	7	Warranty, Registration	9
Extended Shutdown, Preparing For	8	Wiring Diagram	3
<u>F</u>		<u>X</u>	
<u>G</u>		<u>Y</u>	
<u>H</u>		<u>Z</u>	
Hinge	8		
<u>I</u>			
<u>J</u>			
<u>K</u>			
<u>L</u>			
Legs	2, 3		
<u>M</u>			
<u>N</u>			
<u>O</u>			
<u>P</u>			
Pallet, Wooden	2		
Pans, Plastic	7		
Parts Department	8		
Parts, Spare	8		
Pilaster Slots	3		
Power Supply	4		
Prep Top, Assembly	5		

HOURS OF OPERATION:

Monday thru Friday 7:30 am - 4:30 pm CST



Traulsen & Co., Inc.

4401 Blue Mound Road Fort Worth, TX 76106

Phone: (800) 825-8220 Fax-Svce: (817) 740-6757

Website: www.traulsen.com

Quality Refrigeration