

Field oriented control of PMSM motor exploiting SLLIMMTM nano and STM32F302x/303x

By Gianluigi Forte, Dino Costanzo

Main components	
STM32F302x STM32F303x	Analog and DSP with FPU ARM Cortex-M4 MCU up to 256KB Flash+48KB SRAM 4 ADCs, 2 DAC ch., 7 comp, 4 PGA, timers, 2.0-3.6 V operation

Introduction

The “3-phase high voltage inverter power board features the STGIPN3H60A (SLLIMMTM-nano) for field-oriented control (FOC) of permanent magnet synchronous motors (PMSM)”, also referred to by the order code STEVAL-IHM045V1, is designed to perform the FOC of sinusoidal-shaped back-EMF PMSMs with or without sensors, with nominal power up to 100 W.

The aim of this technical note is to describe how to setup the STEVAL-IHM045V1 power board to work together with the STM32303C-EVAL control board and the STM32 PMSM FOC SDK firmware and to setup a complete Motor control drives able to run a PMSM motor taking the advantage of the embedded peripheral of the STM32F302x/303x microcontroller.

1. Take benefit of embedded peripheral of STM32F302x/303x

The STM32F302x/303x microcontrollers embed a set of peripherals dedicated to resolve common motor control issues by reducing the number of required external components. [Figure 1](#) shows the overcurrent protection network and the current sensing network that can be implemented using the internal resources of the STM32F302x/303x.

Figure 1 - Overcurrent protection and current sensing network

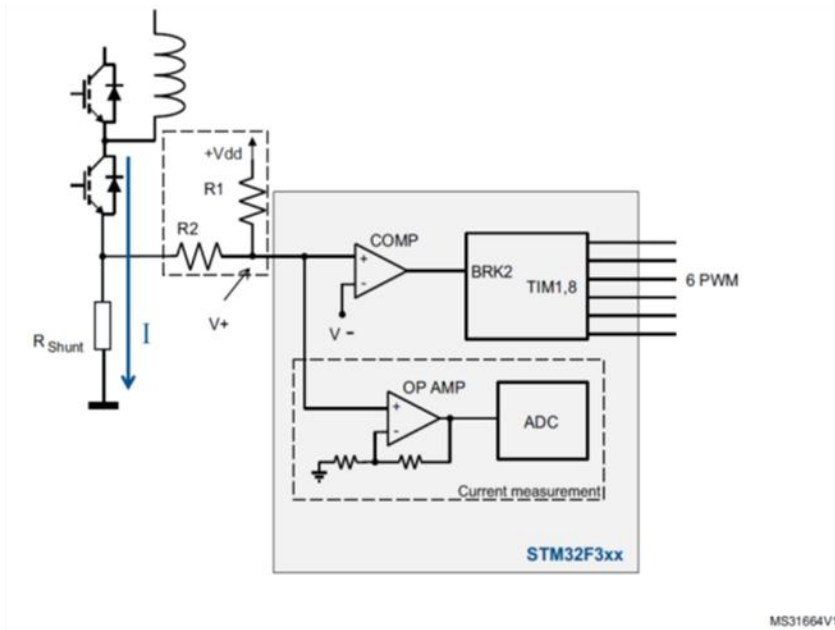

These networks are replicated for each of the shunt resistors present in the power board and for each motor drive having up to six comparator and four operational amplifiers

2. Using Configure the system

The STEVAL-IHM045V1 board can be configured using a set of 0 Ω resistor used as 2-pin jumper with two possible settings: mounted and not mounted. The STEVAL-IHM045V1 board is configured by default to work together with the STM32303C-EVAL taking benefit of the embedded operational amplifiers and comparators. It is possible to verify the resistors configuration in Table 1. This configuration is also called "Direct motor currents sampling from shunt resistors".

Table 1 - STEVAL-IHM045V1 resistors configuration to use embedded OPAMPs and COMPs

Resistors	Configuration
R55, R56, R57	Mounted (0 Ω)
R58, R69, R79	Not mounted

In Figure 2 is shown the layout of the board. In red are highlighted the position of the components that can be modified when is required to swap from “Direct motor currents sampling from shunt resistors” mode to “Use external OPAMP” mode.

Figure 2 - Changing current sensing network

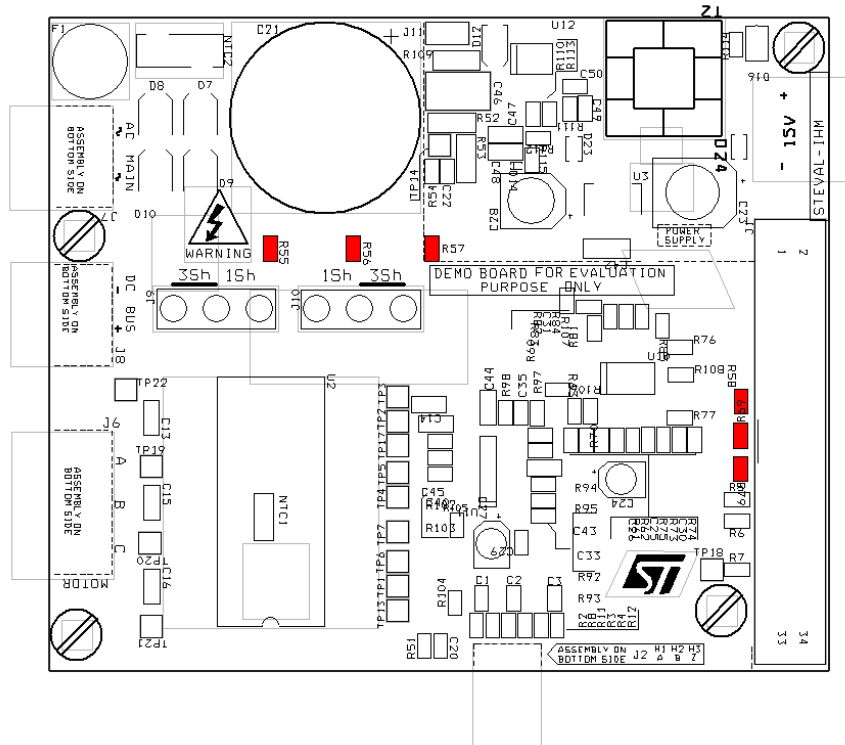

Moreover it is possible to select either single shunt or three shunts for the current sensing network topology as described in Table 2.

Table 2 - Jumpers settings for the current sensing network topology selection

Topology	Jumpers setting	Jumpers settings
Three shunts current reading	J9 between pins 1 and 2 J10 between pins 1 and 2	
Single shunt current reading	J9 between 2 and 3 J10 between 2 and 3	

The STM32303C-EVAL evaluation board supports both single and dual motor control via 34-pin connectors CN2 and CN4, which provide all required control and feedback signals to and from the motor power-driving board.

Some PCB reworks are needed for motor control applications to disconnect peripherals which share I/Os with motor control connectors and connect these I/Os to motor control connectors.

To configure the board for motor control application, please follow the procedure below:

1. Remove even number resistors from R1 to R58 (R2, R4, R6....R56, R58 except R12, R22). The resistor positions on the PCB board are shown in [Figure 3](#).

Figure 3 - Resistor position on the PCB board: even number removing

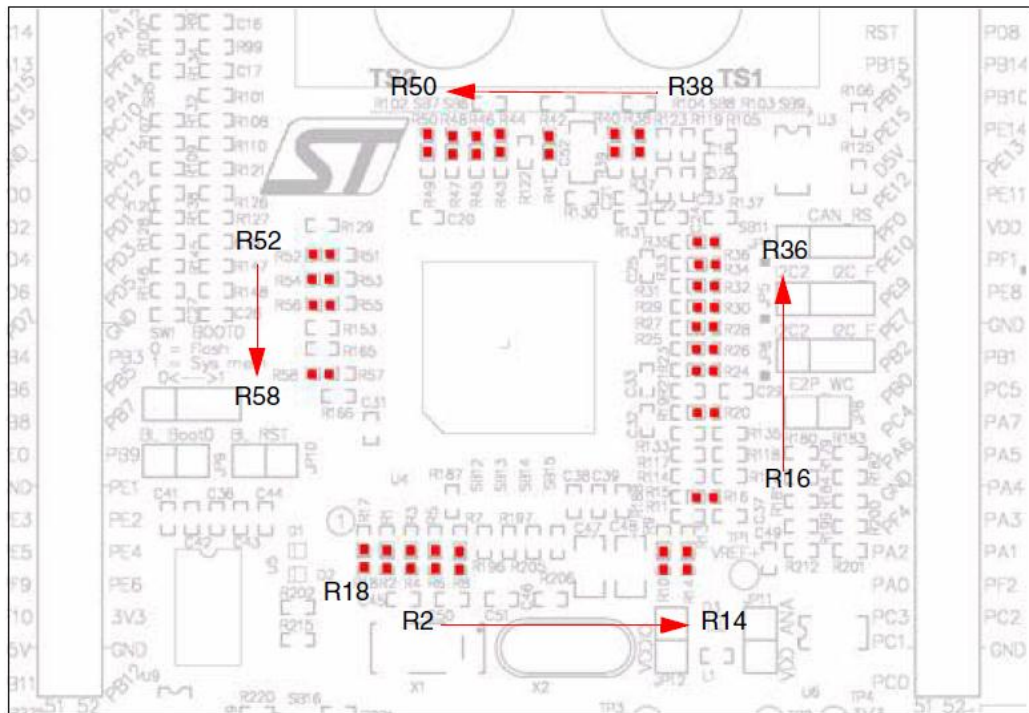

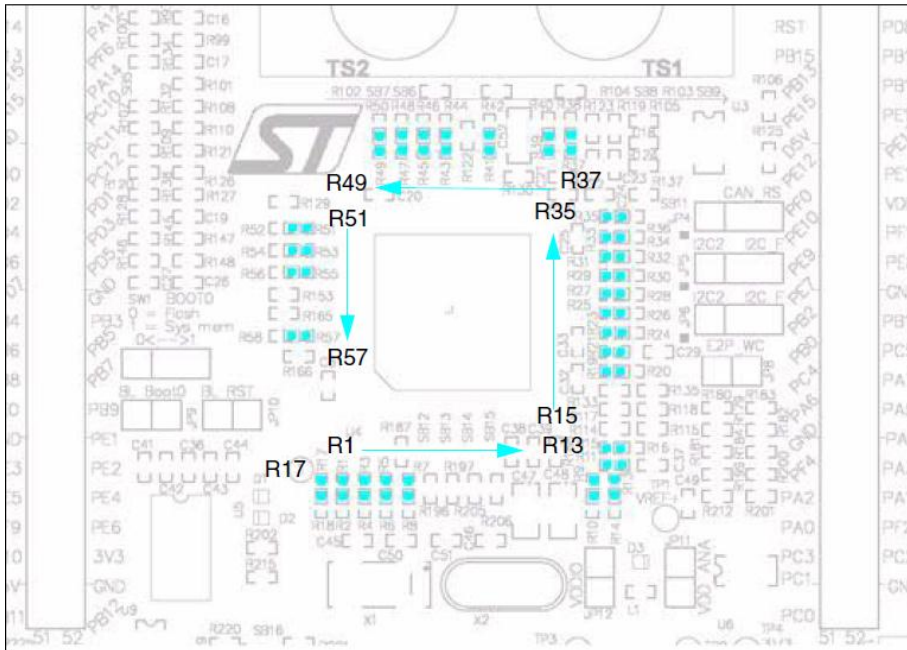

2. Mount odd number resistors from R1 to R58 (R1, R3....R55, R57 except R11 which is mounted by default) with a 0-ohm resistor. The resistor positions on the PCB board are shown in [Figure 4](#).

Figure 4 - Resistor positions on the PCB board: odd number mounting



In the Table 3 are reported the configurations of STM32303C-EVAL board switches and solder bridges to connect the “Direct motor currents sampling from shunt resistors” coming from the STEVAL-IHM045V1 to the embedded OPAMPs and COMPs.

Table 3 - Motor control related switches and solder bridges in STM32303C-EVAL

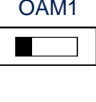
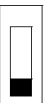
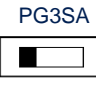
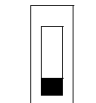
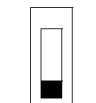
	3SA	PG3SA	PGM	OAM	Other condition	Description
Motor 1					R113, R116 mounted SB2 open	MC1_CurrentA+ connect to OPAMP1_IN+(PA1) MC1_CurrentB+ connect to OPAMP2_IN1+(PA7) MC1_CurrentC+ connect to OPAMP2_IN2+(PD14)
Motor 2					R132, R134 mounted SB5 open	MC2_CurrentA+ connect to OPAMP3_IN+(PB0) MC2_CurrentB+ connect to OPAMP4_IN2 +(PB13) MC2_CurrentC+ connect to OPAMP4_IN1+(PB11)

In [Figure 5](#) is shown the section of the STM32303C-EVAL board schematic related to the motor control signal conditioning that can be useful to understand the configuration of the switched and solder bridge described in [Table 3](#).

Figure 5 - Schematic of motor control section of the STM32303C-EVAL

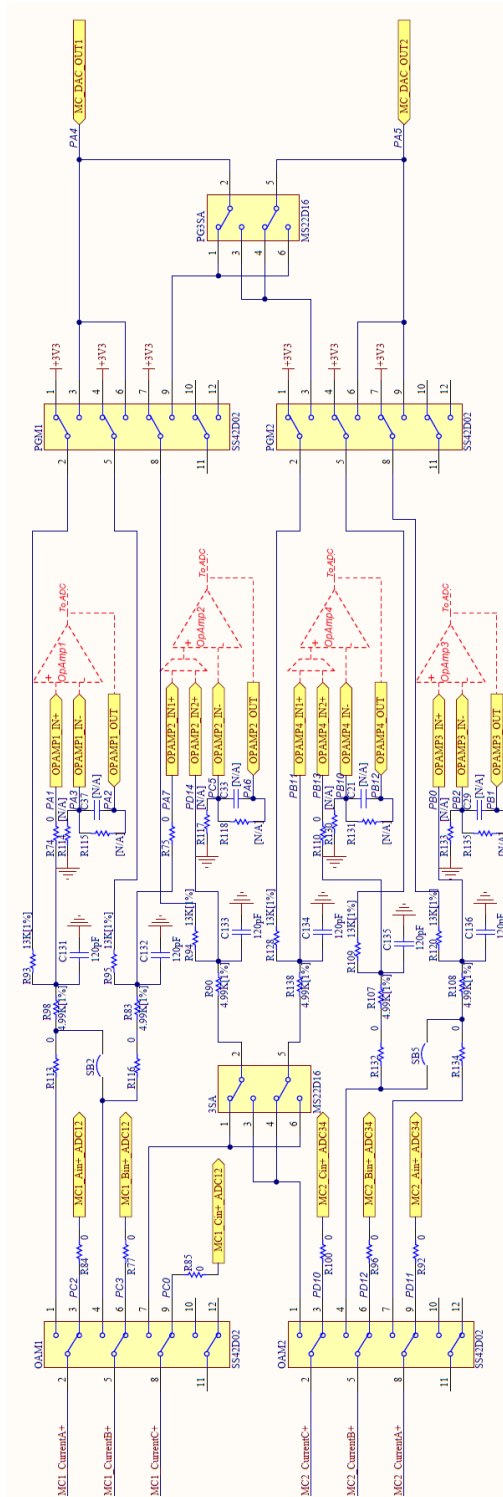

3. How to configure the firmware

For project based on STM32F302/303, the STM32 FOC SDK v3.4 supports the embedded PGA and the hardware over current protection for the following configurations:

1. Single drive using single shunt and three shunts current feedback topologies,
2. Dual drive using any combination of single shunt and three shunts current feedback topologies.

To enable these functionalities is possible to check the “Embedded PGA” and/or the “Embedded HW OCP” radio buttons in the ST MC workbench like shown in figure below.

Figure 6 - Schematic of daughter board

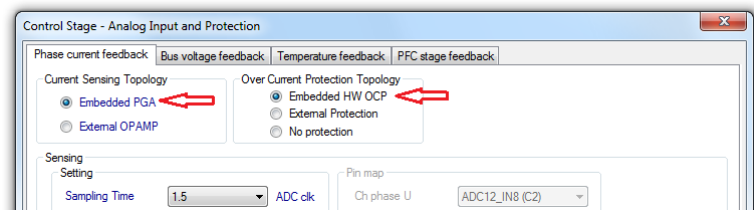

4. Support material

Related design support material
STM32303C-EVAL – product evaluation board for STM32F303xx microcontrollers
STEVAL-IHM045V1 - 3-phase high voltage inverter power board for FOC based on STGIPN3H60A (SLLIMM™-nano)
Documentation
Datasheet STM32F303x
Datasheet STM32F302x
User manual UM1567 - STM32303C-EVAL evaluation board
User manual UM1052 - STM32F05xx/STM32F100xx/STM32F103xx/STM32F2xx/STM2F30x/STM32F4xx PMSM single/dual FOC SDK v3.4
User manual UM1703 - 3-phase high voltage inverter power board for FOC based on STGIPN3H60A (SLLIMM™-nano)

5. Revision history

Date	Version	Changes
28-Apr-2014	1	Initial release
29-Apr-2014	2	Updated title in cover page.

Please Read Carefully

Information in this document is provided solely in connection with ST products. STMicroelectronics NV and its subsidiaries ("ST") reserve the right to make changes, corrections, modifications or improvements, to this document, and the products and services described herein at anytime, without notice.

All ST products are sold pursuant to ST's terms and conditions of sale.

Purchasers are solely responsible for the choice, selection and use of the ST products and services described herein, and ST assumes no liability whatsoever relating to the choice, selection or use of the ST products and services described herein.

No license, express or implied, by estoppel or otherwise, to any intellectual property rights is granted under this document. If any part of this document refers to any third party products or services it shall not be deemed a license grant by ST for the use of such third party products or services, or any intellectual property contained therein or considered as a warranty covering the use in any manner whatsoever of such third party products or services or any intellectual property contained therein.

UNLESS OTHERWISE SET FORTH IN ST'S TERMS AND CONDITIONS OF SALE ST DISCLAIMS ANY EXPRESS OR IMPLIED WARRANTY WITH RESPECT TO THE USE AND/OR SALE OF ST PRODUCTS INCLUDING WITHOUT LIMITATION IMPLIED WARRANTIES OF MERCHANTABILITY, FITNESS FOR A PARTICULAR PURPOSE (AND THEIR EQUIVALENTS UNDER THE LAWS OF ANY JURISDICTION), OR INFRINGEMENT OF ANY PATENT, COPYRIGHT OR OTHER INTELLECTUAL PROPERTY RIGHT.

ST PRODUCTS ARE NOT DESIGNED OR AUTHORIZED FOR USE IN: (A) SAFETY CRITICAL APPLICATIONS SUCH AS LIFE SUPPORTING, ACTIVE IMPLANTED DEVICES OR SYSTEMS WITH PRODUCT FUNCTIONAL SAFETY REQUIREMENTS; (B) AERONAUTIC APPLICATIONS; (C) AUTOMOTIVE APPLICATIONS OR ENVIRONMENTS, AND/OR (D) AEROSPACE APPLICATIONS OR ENVIRONMENTS. WHERE ST PRODUCTS ARE NOT DESIGNED FOR SUCH USE, THE PURCHASER SHALL USE PRODUCTS AT PURCHASER'S SOLE RISK, EVEN IF ST HAS BEEN INFORMED IN WRITING OF SUCH USAGE, UNLESS A PRODUCT IS EXPRESSLY DESIGNATED BY ST AS BEING INTENDED FOR "AUTOMOTIVE, AUTOMOTIVE SAFETY OR MEDICAL" INDUSTRY DOMAINS ACCORDING TO ST PRODUCT DESIGN SPECIFICATIONS. PRODUCTS FORMALLY ESCC, QML OR JAN QUALIFIED ARE DEEMED SUITABLE FOR USE IN AEROSPACE BY THE CORRESPONDING GOVERNMENTAL AGENCY.

Resale of ST products with provisions different from the statements and/or technical features set forth in this document shall immediately void any warranty granted by ST for the ST product or service described herein and shall not create or extend in any manner whatsoever, any liability of ST.

ST and the ST logo are trademarks or registered trademarks of ST in various countries.

Information in this document supersedes and replaces all information previously supplied.

The ST logo is a registered trademark of STMicroelectronics. All other names are the property of their respective owners.

© 2014 STMicroelectronics - All rights reserved

STMicroelectronics group of companies

Australia - Belgium - Brazil - Canada - China - Czech Republic - Finland - France - Germany - Hong Kong - India - Israel - Italy - Japan - Malaysia - Malta - Morocco - Philippines - Singapore - Spain - Sweden - Switzerland - United Kingdom - United States of America

www.st.com