



User Manual

High Voltage Testing Set

PGK 25



Guide to this Operating Instruction

Observe info signs!

For fast finding of important information the corresponding text passages are marked with symbols (symbols not stated here are self-explaining):



More and special information concerning the respective subject are available from BAUR.



Important unit information!
In any case, read carefully!



Important information text.

Copyright



© Copyright by BAUR

© BAUR Prüf- und Messtechnik GmbH, A-6832-Sulz / Austria
All rights reserved.

No part of this publication may be reproduced, transmitted, stored in a data processing system or translated into another language without the written permission of BAUR / Sulz, Austria.

Subject to modification!

In the interest of our customers we reserve the rights for modifications due to technical progress.
Illustrations, descriptions and delivery content are therefore not binding.

Preface



This manual contains all information necessary for the correct handling and use of the PGK 25 High Voltage Testing Set. Before using the PGK 25, please read carefully this Operating Instruction. If you have any question, please contact directly:



BAUR Prüf- und Messtechnik GmbH, Raiffeisenstrasse 8
A-6832 Sulz / Austria

Phone +43 / 55 22 / 49 41-0
Fax +43 / 55 22 / 49 41 3

or refer to your nearest BAUR representative.

Safety Precautions



Please read now
and avoid damage
and injury later!

- The PGK 25 High Voltage Testing Set is built in accordance with today's state of engineering and is safe to operate. Individual components and the finished unit are inspected continually by our qualified staff within the framework of our Quality Assurance Provisions. Each unit is subjected to thorough testing prior to shipment.
-

Continued

Safety Precautions, Continued

- It is imperative to every person who is involved with the installation, start-up, operation and maintenance to have read and understood the complete Operating Instructions.

- It is the responsibility of the customer to ensure that only authorized persons may be allowed to use the PGK 25.

Only authorized personnel!

- The user
 - is qualified and properly instructed and has the necessary experience.
 - knows the relevant standards, accident prevention rules and operating conditions.
 - is able to carry out the necessary operations and is aware of the possible dangers involved.
 - must immediately inform his superior about any conditions of the unit that could affect safety.

Use the PGK 25 as directed!

The PGK 25 is a High Voltage Testing Set for insulation testing of cables, windings and insulators.



The local safety and accident prevention regulations are always applicable to the operation of the PGK 25.

Warranty



12 month warranty time

At the customer's **written request** we undertake to repair or replace at our discretion and as quickly as possible all parts that become faulty or useless as the demonstrable result of poor material, faulty design or defective execution.

The **12 month** warranty time starts with delivery. We shall bear the costs of any faulty parts requiring replacement, but not the costs of transport to us and back to the customer, nor the costs of packing and insurance! We shall not be liable for any damage resulting from normal wear and tear, improper handling, non-observance of Operating Instructions and safety regulations.

We shall also refuse to accept any liability if the customer carries out repairs or changes to the unit himself or has others carry out them! The warranty does not cover damage in transit, batteries, fuses and any readjustments in accordance with the Operating Instructions!

We draw attention in addition to the '**General Terms of Sales and Delivery**' of:



BAUR Prüf- und Messtechnik GmbH, Raiffeisenstrasse 8
A-6832-Sulz / Austria

Contents

1. Operating Elements 1-1

2. Packing and Shipping 2-1

Damage during transport 2-1

3. Power supply / Power selection 3-1

Maintenance 3-1

General rule 3-1

4. Setting into operation 4-1

Plotter connector 4-2

5. Guard Connection 5-1

General 5-1

Current measuring device 5-2

Application 5-3

6. Technical Data 6-1

General 6-1

Mechanical Data 6-2

Standard accessories 6-2

Special accessories 6-2

7. Insulation resistance chart 7-1

1. Operating Elements

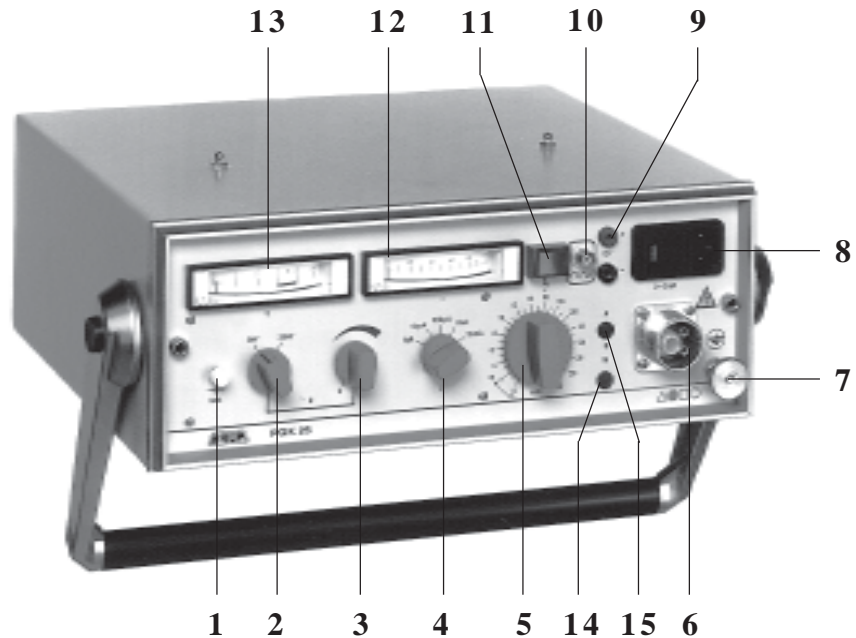

- 1 Push-button switch for battery test
- 2 Selector switch 0 - 5 kV or 0 - 25 kV
- 3 Voltage regulator with 0-locking
- 4 Range selector switch for current indication
- 5 Operating switch with timer and discharge unit
- 6 High voltage output with controlling contact
- 7 Connector for protective earth cable
- 8 Mains connector with power selector and fuses
- 9 Connectors for external battery (12 V)
- 10 Connector for current range plotter
- 11 H.V. control lamp
- 12 μA - meter
- 13 kV - meter with indication for battery test

Option: Guard connection

- 14 Operating mode switch for current measurement
 - 15 Terminal for current measurement
-



Notes

A series of horizontal dotted lines for taking notes, spanning the width of the page.

2. Packing and Shipping

The Test Set is shipped in robust cardboard cartons. If Test Set is not used immediately, store in carton in dry rooms!

Damage during transport

Complaints concerning damage should be made to us without delay, using a standard damage claims form.

Confirmation of visible damage should immediately be obtained from the carrier. The extent and probable cause of the damage should be stated.

If damage is discovered during unpacking, contact the responsible transportation company immediately. Request a written loss assessment and make them responsible for the damage.

We also refer to the 'General Terms of Sales and Delivery' of:



BAUR Prüf- und Messtechnik GmbH, A-6832 Sulz / Austria

3. Power supply / Power selection

The unit is factory-set to 220 -230 V. If the unit is operated under different power, remove power cord and open cover of voltage selector using a small screwdriver. Now the voltage selector drum can be withdrawn and inserted again after selecting.

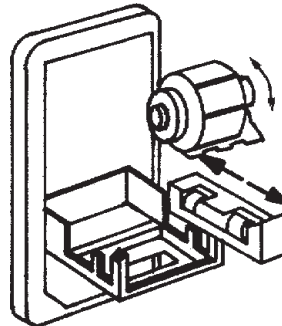

Check also the inserted fuses and the amperage as shown on the typeplate. Close cover by simply pressing on it.

Battery operation should only be performed with fully charged battery.

Maintenance

Units with built in battery must be maintained. Since batteries discharge even when instrument is not in use, batteries must be recharged occasionally.

General rule

Charge batteries after approx.30 days as well as before instrument is put into operation.



Discharged Dryfit batteries should not be put in storage.

4.1 Setting into operation



The PGK 25 is designed in such a way, that no output current is generated which could be harmful in case of body contact. In the process of testing capacitive type test objects however, dangerous charges may occur. In tests where charges of 350 mJ or higher are stored in items with which persons could make contact, special protection measures are required to avoid direct or indirect contact with live parts.

- 1) Connect instrument with protective earth lead (461-308) via protective earth connector (7) with station earth.
- 2) Connect instrument and test object with H.V. cable (460-437).
- 3) Mains operation:
Connect instrument with power cord (554-005). Please pay attention to selected mains voltage!

Battery operation:
Check battery voltage by pressing push-button switch (1). The state of charge of the battery will be indicated by the kV meter. In battery test, the needle must be within the marked range.
- 4) Set range selector switch (2) to the desired range (0-5 kV or 0-25 kV).
- 5) Set voltage regulator (3) to "0".
(Otherwise the instrument cannot be turned on).
- 6) Set range selector switch (4) of amperemeter to maximum value (10 mA).
- 7) The high voltage will be turned on by the timer (5) and the control lamp (11) will be on.
- 8) Now the high voltage can be set to the desired value by turning the voltage regulator (3). The current range selector switch (4) can also be adjusted.
- 9) Only now the timer (5) should be set to the desired operating time. The insulation resistance of the test object, resulting from current and voltage can now be determined by using the attached chart.
- 10) Instrument shutdown; turn timer (5) completely counter-clockwise; H.V. control lamp (11) will be off.
- 11) Once the H.V. lamp is off, the integrated discharge unit will automatically be activated. The connected test objects (capacities) will be discharged slowly via a resistor (125 k Ohms). The discharge time at 6 μ F is approximately 5 seconds.
- 12) For measurements of very low current values:
recommended way of application:
 - operate the PGK in battery mode
 - use the option „Charging current limitation for high capacities“
 For using of the option „Charging current limitation for high capacities“, the following points need to be considered:
 - the voltage indication error is maximum 125V (at 1mA)
 - The discharging periods need to be doubled



Before touching the test object short-circuit test object and connect it to earth!

4.2 Plotter connector

It is possible to plot the test current as function of time to a external plotter via the plotter connector (10) of the PGK 25. The output voltage is function of the current range (4) 200mV at full-scale deflection of the internal ampermeter

5. Guard Connection

General

Starting with series 16 of the PGK 25, a Guard connection is provided as an option. With the feature, a variety of measurements jobs can be performed where the connections for the shield and current measuring terminal are separately mounted.

H.V. connection



In the Guard option, resistors with 1 k Ω / 200W are integrated in the current measuring lead (461-408) and in the shield connection of the H.V. lead. These resistors serve for the protection of the instrument against transient voltages.

The resistors in the connection leads must be checked for damage after high voltage breakdown of test objects with high capacity (> 0.5 μ F) or heavy mechanical stress.

Current measuring device

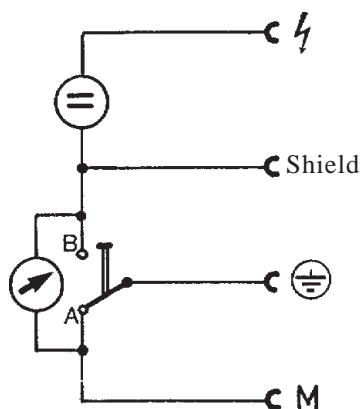

The current measuring device of the PGK 25 has 5 measuring ranges from 1 μA to 10 mA. Due to the separately mounted connectors for shield and current measuring terminal M, spurious currents can be excluded from measurements.

Operating mode A: (test object connected to earth)

With the operating mode switch (14) in position "A", the current measuring terminal (15) is connected to earth. The current measuring device acquires all currents which flow from the H.V. output to earth. Internal insulation currents as well as corona currents from test configuration are also acquired by the current measurement. Through the shield connection, partial currents (e.g. surface currents on insulators) can be returned to the high voltage source, without being acquired by the current measuring device. If the shield connection is not used it must be isolated from earth, otherwise the μA -meter will be short-circuited.

Operating mode B: (test object not connected to earth)

With the operating mode switch (14) in position "B", the current measuring terminal (15) is electrically isolated. The current measuring device acquires all currents which are conducted through the current measuring terminal (15). The insulation currents and corona currents which flow from the instrument or the test configuration to earth, will not be acquired by the current measuring device. The shield connection may be connected to earth. The test object must be configured in such a way, that it is insulated from earth.



The test lead may not be interrupted during testing, otherwise the test lead could carry high voltage!

Application

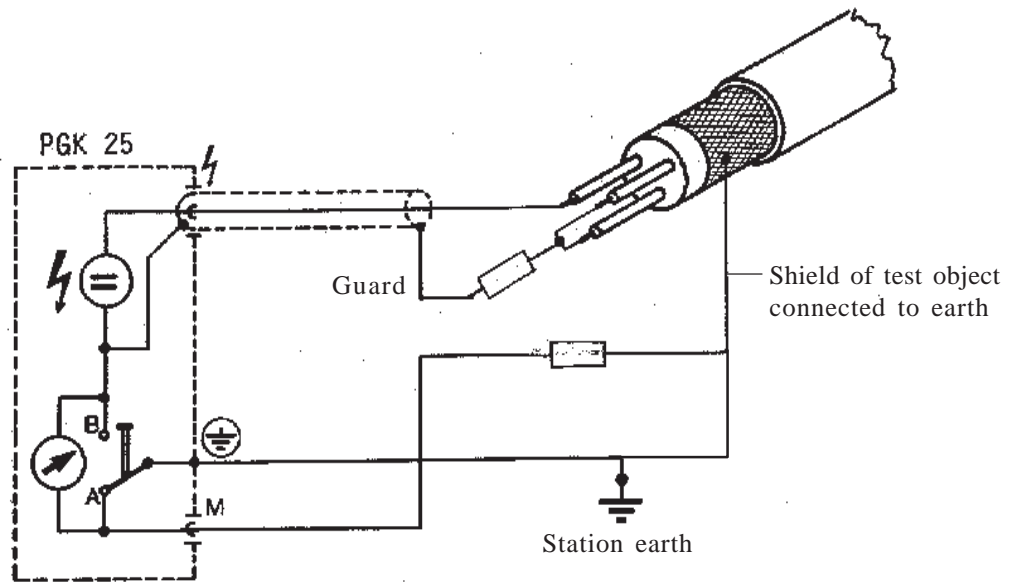

Insulation test between a conductor and the shield.
 The insulation currents between the conductors will be ignored.

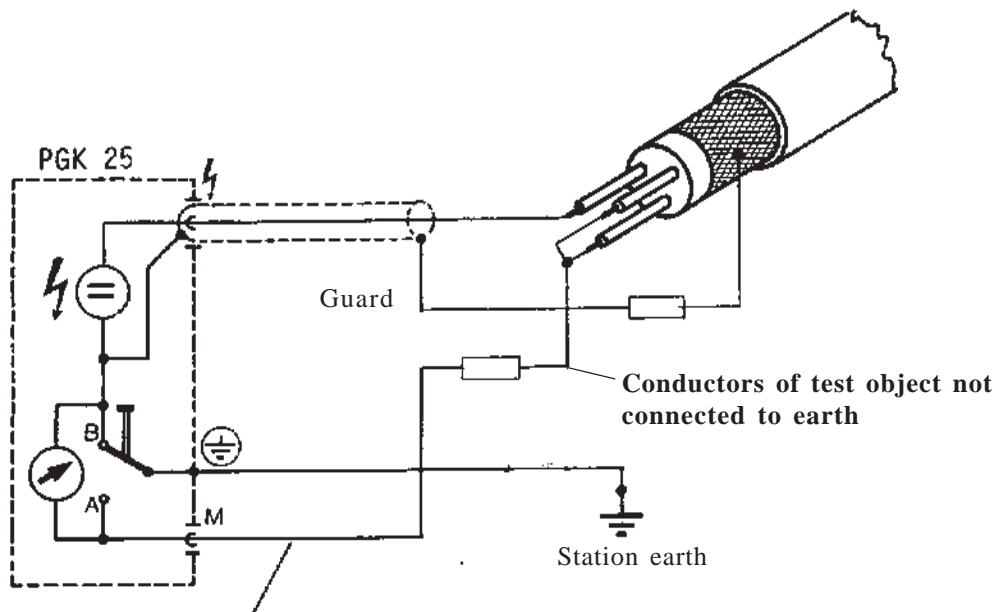

The test lead may not be interrupted during testing, otherwise the test lead could carry high voltage!

Insulation test between the conductors. The insulation currents between the conductors and the shield will be ignored.

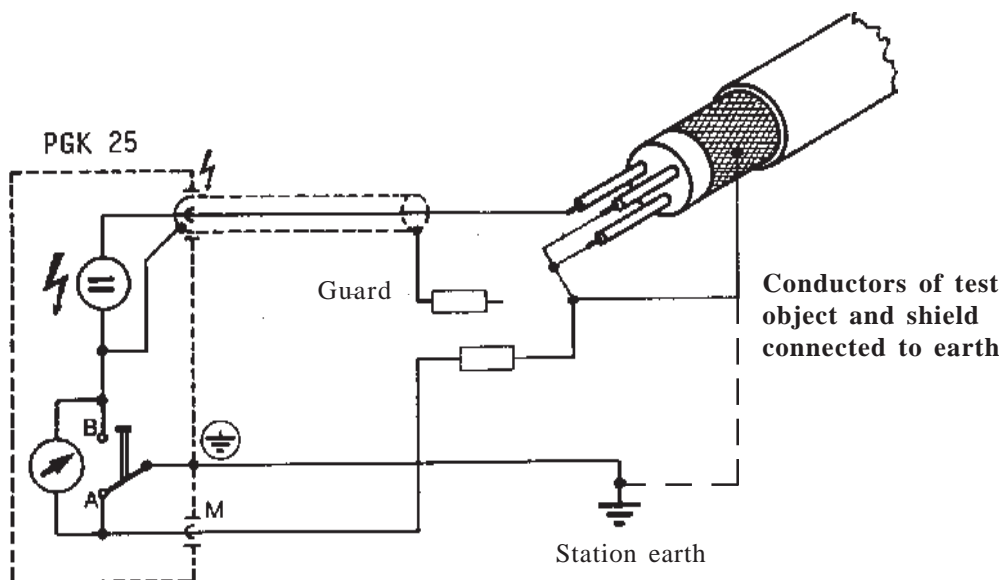

Insulation test between conductor and shield. All of the insulation currents will be measured.

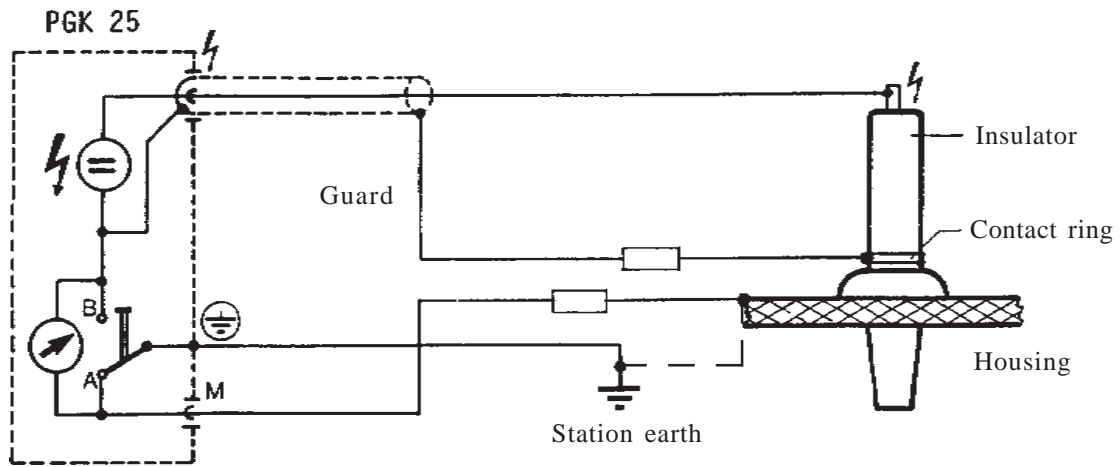

Insulation test of a H.V. insulator. Under this test, the surface currents of the insulator will be ignored.

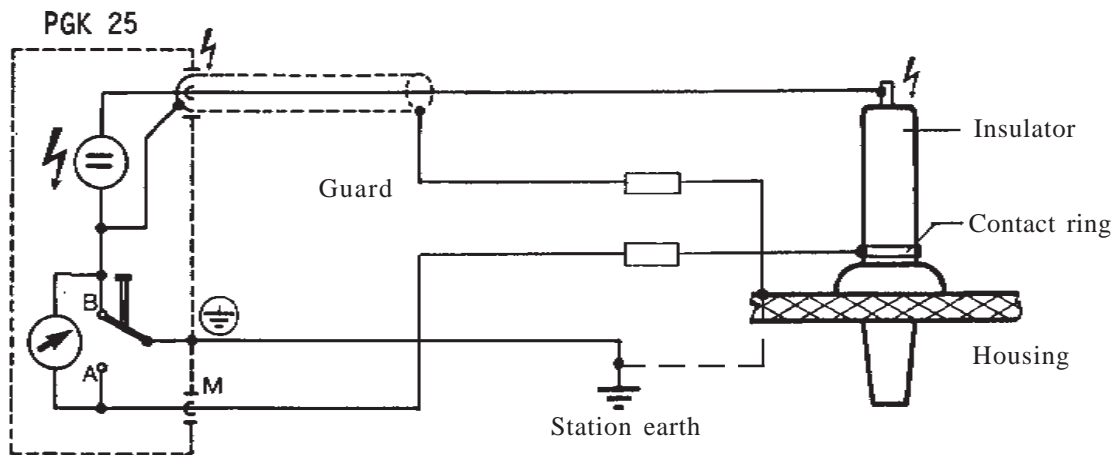

The test lead may not be interrupted during testing, otherwise the test lead could carry high voltage!

Measurement of surface currents. Insulation leakage currents which are flowing to the housing will be ignored during this test. Very small surface currents can be measured.

6. Technical Data

General

Operating voltage	110-120 V / 220-230 V / 240 V, 50/60 Hz built-in battery 12 V. External battery 12 V can be connected to terminals (9) on front panel. (battery cable AA 3 red, Ident. No. 460-439 and AA 3 black, Ident. No. 460-458 available as accessories).
Output voltage	Stepless controllable with switch (2) 0-5 kV and switch (3) 0-25 kV. Independent of load up to 1 mA output current.
Output current	Short-circuit current approx. 3 mA; continuous current 1 mA at 25 kV.
Voltage indication	Voltage measurements are performed directly at the output via a precision measuring resistor (1%). The scale is divided into 2 ranges; 0-5 kV and 0-25 kV maximum deflection. Meter: Class 1.5
Current indication	The current display is divided into 5 ranges: 1 μ A, 10 μ A, 100 μ A, 1mA, 10 mA maximum deflection. Currents from 50 nA are measurable. The current is measured via an operational amplifier and displayed on a meter: Class 1.5
Plotter output	For current recordings, a plotter with a floating input can be connected to the insulated BNC connector (10). The same test voltage is available for each current range (e.g. 0-200 mV).
Built-in battery	12 V, 6.5 Ah operating time at 2/3 load approx. 30 minutes. The battery is charged by the internal charging unit (instrument must be connected to mains). The charging time is approximately 24 hours.
0-locking (3)	The instrument can be switched on only, when the kV controller (3) is in the zero position. (Locked against unintentional instrument turn on!)
Timer (5)	0-30 minutes
Integrated discharge unit	Discharge load 2000 Ws (6 μ F at 25 kV= accordingly).
Relative humidity	not condensing
Ambient temperature	working: 0...+45° C storage: -20...+60° C

Mechanical Data

Dimensions	365 x 135 x 394 mm (w x h x d)
Weight	approximately 16.5 kg (including cover and H.V. cable)
Colour	RAL 7035 texture

Standard accessories

1 H.V. connection cable	Ident. No. 462-274
1 Ground line	Ident. No. 461-308
1 Mains cable	Ident. No. 554-xxx
1 Leather bag for HV connection cable	Ident. No. 470-880

Special accessories

Leatherbag LT 25	Ident. No. 411-519
2 Battery connection cables ret/ black	Ident. No. 470-067
Discharge rod ES 45	Ident. No. 411-501
Guard connection	Ident. No. 471-094
Ground monitoring	Ident. No. 470-854

Accesorios - Conexion del anillo de guarda

-Conjunto de actualización	Ref. No. 470-854
1 Cable de conexión de Alta Tensión	Ref. No. 461-307
1 Cable de tierra	Ref. No. 461-308
1 Cable de red	Ref. No. 554-005
1 Extractor de lamparitas	Ref. No. 541-169
2 Fusibles	Ref. No. 563-073
1 Cable de ensayo	Ref. No. 461-408

7. Insulation resistance chart

