



User's Manual

KM-560

One needle, drop feed,
needle feed sewing machine

KM-560-7

One needle, drop feed,
needle feed sewing machine
with automatic thread trimmer
(Equipped with FORTUNA AC
SERVO MOTOR)



SUNSTAR MACHINERY CO., LTD.

- 1) For proper use of the machine, thoroughly read this manual before use.
- 2) Keep this manual in a safe place for future reference in case the machine breaks down.

MME-050629



- 1. Thank you for purchasing our product. Based on the rich expertise and experience accumulated in industrial sewing machine production, SUNSTAR will manufacture industrial sewing machines, which deliver more diverse functions, high performance, powerful operation, enhanced durability, and more sophisticated design to meet a number of user's needs.**
- 2. Please read this user's manual thoroughly before using the machine. Make sure to properly use the machine to enjoy its full performance.**
- 3. The specifications of the machine are subject to change, aimed to enhance product performance, without prior notice.**
- 4. This product is designed, manufactured, and sold as an industrial sewing machine. It should not be used for other than industrial purpose.**



SUNSTAR MACHINERY CO., LTD.

Table of contents

Safety rules for machine	4
1. Specification	8
1) Sewing machine	8
2) Motor	8
3) Peripheral automation device (optional)	8
2. Installation	9
1) Installation of machine head	9
2) Installation of knee lifting solenoid and power switch box (for automatic thread trimming)	9
3) Installation of oil fan	10
4) Adjustment of belt tension	10
5) Installation of belt cover	10
6) Installation of the program unit (for automatic trimming type)	11
7) Installation of the thread stand	11
8) Assembly of the location detector and its control method (for automatic trimming type)	12
9) Oil supply	13
10) Checking stop position of the sewing machine (for automatic trimming type)	14
11) Reverse button function (for automatic trimming type)	14
3. Adjustment of the machine	15
1) Inserting the needle	15
2) Removing bobbin	15
3) Winding the lower thread	15
4) Routing the upper thread	16
5) Adjusting the thread tension	16
6) Adjusting the tension of the presser foot	18
7) Adjusting the needle and feed dog timing	18
8) Adjusting the position of the feed dog	19
9) Adjusting timing of needle and hook	20
10) Clearance adjustment between the upper side of hook stopper and the upper side of needle board groove	21
11) Clearance adjustment between hook and opener	21
12) Adjusting feed dog height	22
13) Adjusting the auxiliary presser foot and the upper feed presser foot	22
14) Adjusting timing of the auxiliary presser foot, the upper feed foot and the needle	24
15) Adjusting stroke of upper feed presser foot	24
16) Adjusting safety device	25
17) Adjusting the trimming device	25
18) Replacing movable knife and fixed knife	31
19) Adjusting thread release (for automatic trimming type)	31
4. Causes of troubles and troubleshooting	32
1) Sewing machine troubleshooting	32
5. Table drawing	34

Safety Rules for Machine

Safety labels in the manual are categorized into danger, warning and caution.
Failure to follow the safety rules may result in physical injuries or mechanical damages.
The safety labels and symbols are defined as follows.

[The meaning of the safety labels]



Danger Instructions here shall be observed strictly.
Otherwise, the user will be killed or suffer severe physical injuries



Warning Instructions here must be observed, or the user could suffer fatal or severe physical injuries.



Caution Instructions here should be observed, or the user could face physical injuries or mechanical damages.

[The meaning of symbols]





This symbol means a must-not.



This symbol means a must for safety.



This symbol means that an electric shock may be caused if the instruction is not followed properly.

<p>1-1) Machine mobilization</p>  <p>Danger</p>	<p>Only personnel with a full understanding of the safety rules should move the machines. The following directions must be observed when delivering the machines.</p> <ul style="list-style-type: none"> Ⓐ At least two persons should work together. Ⓑ In case the machine should be transported, please wipe the oil covered on the machine to prevent accidents
<p>1-2) Machine Installation</p>  <p>Caution</p>	<p>Because physical damage such as the functional obstacles and breakdowns are likely to occur according to the environment in which the machine is being installed. Therefore, the following preconditions should be fulfilled.</p> <ul style="list-style-type: none"> Ⓐ Please keep the order from top to bottom when unpacking the package. Especially, mind that the nail on the boxes. Ⓑ Because machines are apt to be contaminated and corroded by dust and moisture, you should install the climate controller and should clean the machines regularly. Ⓒ Keep the machines out of the direct rays of the sun. Ⓓ Keep both sides and the backside of the machines off at least 50cm from the wall to secure enough space to repair. Ⓔ Don't run the machine near the places with the dangers of explosion. Don't run the machine near the places with the dangers of explosion, including the places where the spraying product like aerosol are used in large quantities or oxygen are dealt with, unless the exact actions concerning the operation are guaranteed to avoid the explosion. Ⓕ Because of the peculiarity of the machine, any illuminators are not equipped. So, users should install the lighting apparatus around the working area. <p>[Note] The details about the installment of the machine are described in No. 2 Installations.</p>
<p>1-3) Troubleshooting</p>  <p>Danger</p>	<p>In need of troubleshooting, it should be done by the trained A/S engineer of our company.</p> <ul style="list-style-type: none"> Ⓐ Ahead of cleaning and repair, be sure to shut off the power supply. And wait for about 4 minutes till the machine discharges completely. Ⓑ Even a part or all of the machine should not be modified without any consultation with our company. Ⓒ In case of repair, you should change the damaged part into the standard article of our company. Ⓓ After repair, please put again the safety cover disjointed while repairing.

1-4) Machine Operation



KM-560 series are manufactured for industry use to sew textiles and other similar material. In case of running the machine, users should observe the following things.

- Ⓐ Ahead of operating the machine, please read the manual and understand fully the details on its operation.
- Ⓑ Don't forget to put on the garment suited for the safe work.
- Ⓒ Keep your hands or a part of the body away from the running part of the machine like a needle, hook, thread take-up spring and pulley etc.
- Ⓓ Don't remove any kind of cover for safety while running the machine.
- Ⓔ Be sure to connect the earthed line.
- Ⓕ Before opening the electric box such as a control box, be sure to shut off the power supply and make sure that the power switch should be put on "off."
- Ⓖ When threading the needle or before checking after sewing, be sure to stop the machine.
- Ⓗ Don't switch on the power supply with the foot on the pedal.
- Ⓘ Don't run the machine when the cooling fan are not running. Be sure to clean the air filter in the control box once a week.
- Ⓚ If possible, keep off from the strong electronic wave like a high frequency welding machine.



Always start the machine with safety covers in place since fingers or hands could be injured or cut off by the belt. Turn off the power switch during check-ups or adjustments.

1-5) Safety Device



- Ⓐ Safety Label: Suggestions while running the machine are stated.
- Ⓑ Thread take-up spring cover: the device to prevent the human body from touching the thread take-up spring.
- Ⓒ Belt cover: the device to prevent hands, feet and clothing from getting jammed by the belt.
- Ⓓ Finger guard: the device to prevent fingers from contacting the needle.

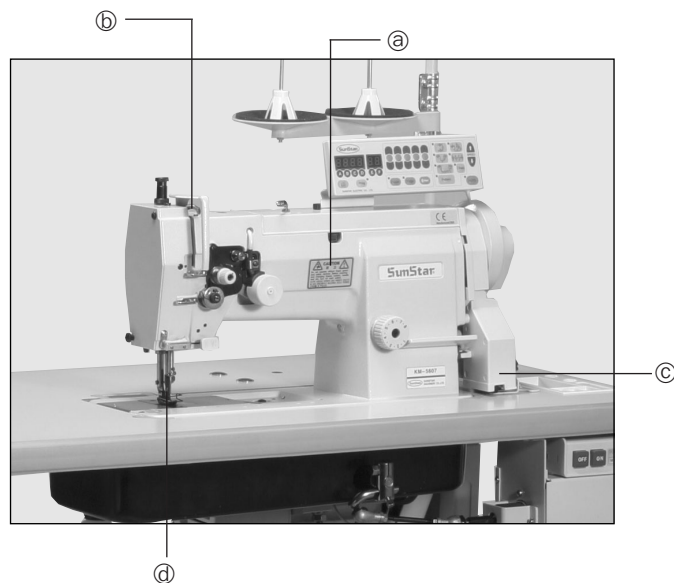

1-6) Position of Caution Mark

CAUTION
경고



Do not operate without finger guard and safety devices. Before threading, changing bobbin and needle, cleaning etc. switch off main switch.
손가락 보호대와 안전장치 없이 작동하지 마십시오.
실, 보빈, 바늘교환시나 청소전에는 반드시 주전원의 스위치를 꺼 주십시오.

CAUTION
경고



Hazardous voltage will cause injury. Be sure to wait at least 360 seconds before opening this cover after turn off main switch and unplugging a power cord.
고압 전류에 의해 감전될 수 있으므로 커버를 열 때는 전원을 내리고 전원 플러그를 뽑고 나서 360초간 기다린 후 여십시오.

“Caution” is attached to the machine for safety.
In case of starting to run the machine, read the directions of “Cautions” carefully.

[Position of Caution Mark]

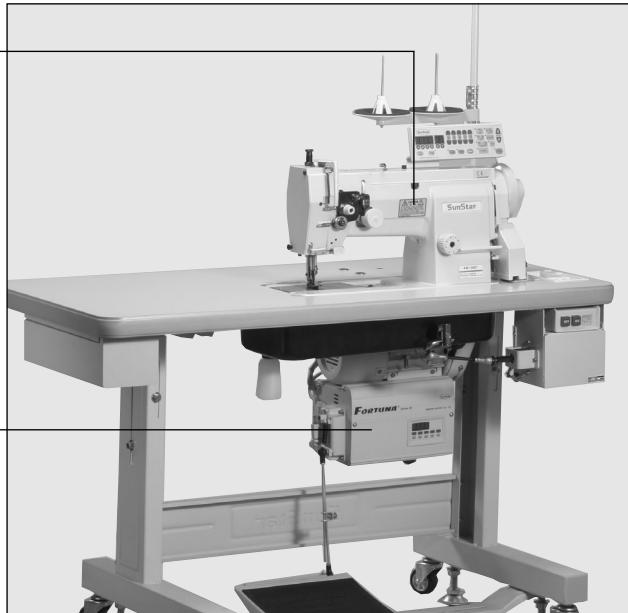

1-7) Content of “Caution”



CAUTION
경고



Do not operate without finger guard and safety devices. Before threading, changing bobbin and needle, cleaning etc. switch off main switch.
손가락 보호대와 안전장치 없이 작동하지 마십시오.
실, 보빈, 바늘교환시나 청소전에는 반드시 주전원의 스위치를 꺼주십시오.

CAUTION
경고



Hazardous voltage will cause injury. Be sure to wait at least 360 seconds before opening this cover after turn off main switch and unplugging a power cord.
고압 전류에 의해 감전될 수 있으므로 커버를 열 때는 전원을 내리고 전원 플러그를 뽑고 나서 360초간 기다린 후 여십시오.

1

Specification

1) Sewing machine

Item	KM-560-7(Trimming type)	KM-560(Ordinary type)
Usage	Heavy materials ~ Ultra thin materials	
Max speed	3,000 SPM	
Max stitch length	8 mm	
Needle bar stroke	34.2 mm	
Vertical stroke of upper feed presser foot and auxiliary presser foot	2 ~ 5.5mm	
Presser foot height	Manual : 10.5 mm, Knee : 16 mm	
Needle	DP × 17 #22 (#14~#25)	
Hook	2 horizontal rotations 2.5 times trimming hook	2 horizontal rotations 2.5 times trimming hook
Reverse sewing	Reverse button & Reverse lever	Reverse lever
Conveying device	Unision feeding (Needle, Feed dog, Upper feed presser foot)	
Lubrication	Semi-automatic drop oiler	
Bed scale	475 × 177mm	
Power	1 Phase 110/220V, 3 Phase 220V	1 Phase 110/220V, 3 Phase 220/380V

2) Motor

① Servo motor controller

MODEL	VOLT	WATT	HERTZ
SC55-1B	1 Phase 110V	550W	50/60 Hz
SC55-1B	1 Phase 220V	550W	50/60 Hz
SC55-3B	3 Phase 220V	550W	50/60 Hz

② Clutch motor

MODEL	VOLT	WATT	HERTZ
HEC-1706(1 Phase)	110/220V	400W	50/60 Hz
HEC-1705(3 Phase)	220/380V	400W	50/60 Hz

3) Peripheral automation devices (optional)

Optional device	Model	Usage
AUTO KNEE LIFTING SYSTEM	SPF-4	A solenoid operating structure where the presser foot gets lifted automatically with pedal reverse gear stage 1 operation. <ul style="list-style-type: none"> • max. stroke: 46 mm • input voltage: DC 24V (DC 24 ~ 46V) • induction at 46 mm stroke: 10kg
PRODUCTION COUNTER	SCOUN-1	A counting device which indicates the completed quantity on the program unit panel, including added, subtracted, corrected or remaining quantity along with other performance rates.
MATERIAL EDGE SENSOR	SEDG-1C SEDG-2C	A device that senses the edge or thickness of the sewing material to stop the machine without manual pedaling. Available in two types: SEDG-1B for edge sensing type and SEDG-2B for thickness sensing type.
STANDING PEDAL	SPDL-1 SPDL-2	An essential device when one person is operating multiple sewing machines. Has different pedals for acceleration, thread trimming, presser foot and ascending pedal. Types consist of SPDL-1 for fixed speed and SPDL-2 for variable speed.

Caution

	▶ Installation of the machine should be performed by a trained engineer.
	▶ Any electrical wiring must be performed by a qualified technician or agent.
	▶ The machine weighs over 38 kg. At least 2 persons should carry out the installing work.
	▶ Plug in after the installation is complete. If the operator mistakenly steps down on the pedal with the plug in, the machine will start automatically and can cause physical injuries.
	▶ Connect the ground (earth) wire. An unstable connection may result in an electric shock or a malfunction.
	▶ Place the belt cover on top of the machine.
	▶ Use both hands when bending the machine backwards or returning it to the normal position. Using only one hand can lead to severe hand injuries due to the weight of the machine.

1) Installation of machine head

- ※ Insert two machine head hinges ① into the bed holes. After aligning it with the rubber hinge ②, stand the machine on the rubber cushion ③ that is in the direction of the user. (See Figure 1)

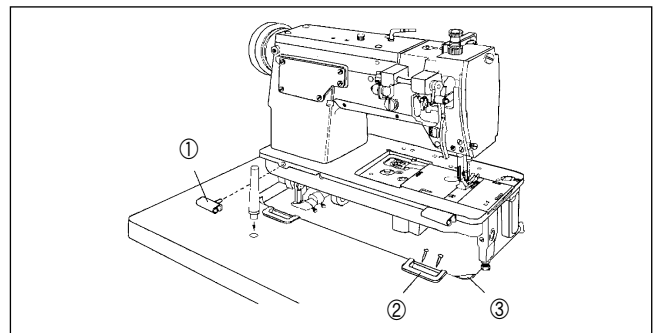

[Figure 1]

2) Installation of knee lifting solenoid and power switch box (for automatic thread trimming)

(The place where the knee lifting solenoid box should be assembled is also included.)

- (1) When attaching the power switch box ⑥, refer to Figure 2 to make sure that it is placed at the very center of the solenoid bracket.
- (2) After attaching the solenoid onto the table, unfasten the screw ④ to adjust the center of middle linking bar ① and the center of solenoid shaft ② in parallel position with the lower side of the table ③. After the adjustment is over, fasten the screw tightly. (See Figure 2: An assembling position diagram can be found inside the solenoid box.)
- (3) The presser foot height of the sewing machine can be adjusted after unfastening the fixing nut ⑤ and then turning the middle linking bar ① clockwise to raise and counterclockwise to lower. After finishing the adjustment, tightly fasten the fixing nut ⑤.
- (4) According to the installation position of knee-lifting solenoid, the operation noise, operation load and presser foot elevation range may differ. Please assemble so that the machine will operate smoothly.

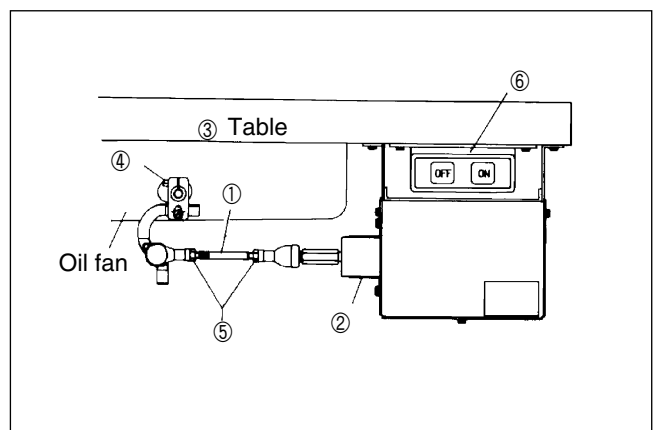

[Figure 2]

3) Installation of oil fan

- ※ Insert the projecting part of the oil fan ② into the respective machine holes on the lower side of the table ①, and then push securely to the right. Fix the oil fan to the four fixing spots ③ using 4 nails. (See Figure 3)

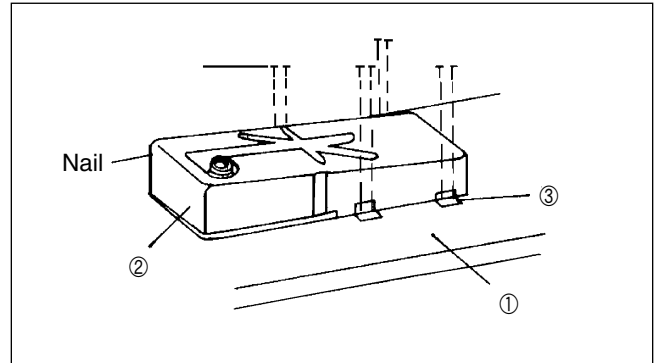

[Figure 3]

4) Adjustment of belt tension

- Once the motor is installed, when the fixing nuts ①, ② are fully unfastened on both sides, tension is created to the belt ④ due to the weight balance of the motor ③. At this moment, fasten the fixing nut ① first, then fasten the fixing nut ② tightly. (See Figure 4)

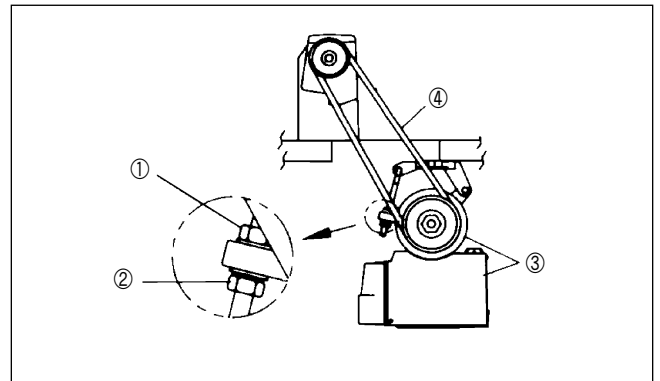

[Figure 4]

5) Installation of belt cover

- (1) Before attaching the belt cover "B" ① to the machine body, assemble in advance the rubber collar, fixing washer and fixing screw on the to-be-attached side of the cover as can be seen in picture "K" of Figure 5.
- (2) Lay down the machine on the back and then attach belt cover "B" ① onto the machine body. (See Figure 5)

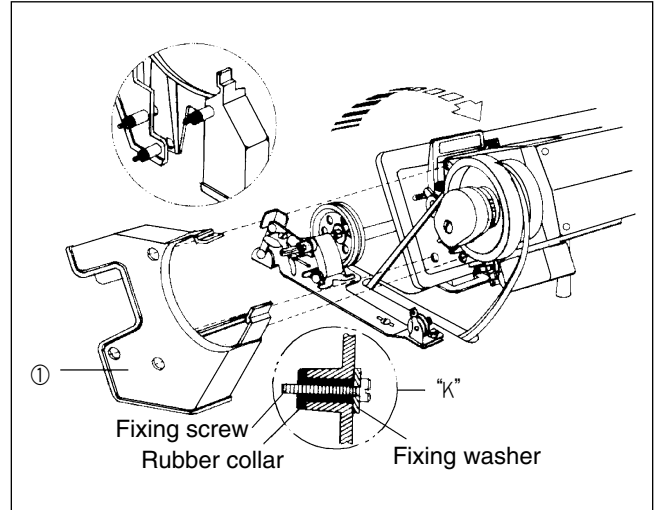

[Figure 5]

- (3) Fasten belt cover "A" ② to the machine body and the top cover with the fixing screw ③, as can be seen in Figure 6. And make sure that the belt cover "A" ② keeps balance with the belt cover "B" ① that was already attached. (See Figure 6)

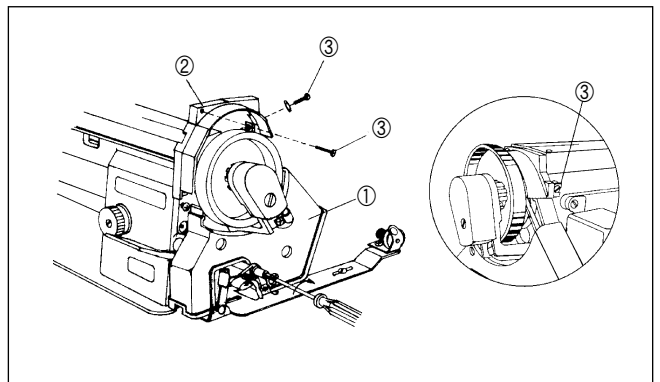

[Figure 6]

- (4) Attach belt cover "C" ④ to the table. Make sure that the belt properly operates without interference from the belt cover "C". (See Figure 7)

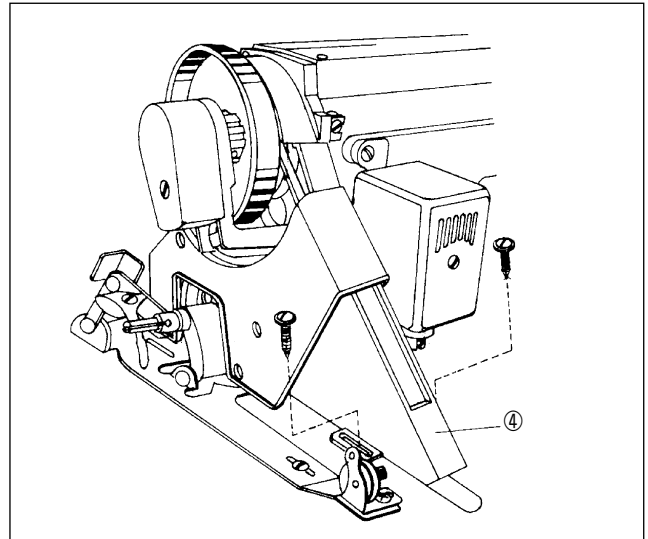

[Figure 7]

6) Installation of the program unit (for automatic trimming type)

- (1) Fix the bracket ② onto the program unit ①, using 4 fixing screws ③.
- (2) Fasten fixing nuts ⑤ to bracket bolts ④, as done in (1). Make sure that there is 3~4 mm distance between the lower parts of fixing nuts ⑤ and the program unit-supporting bolts ④, as can be seen in Figure 8.
- (3) Finally, fasten the program unit tightly to the machine head by using two fixing bolts ⑥. (See Figure 8)

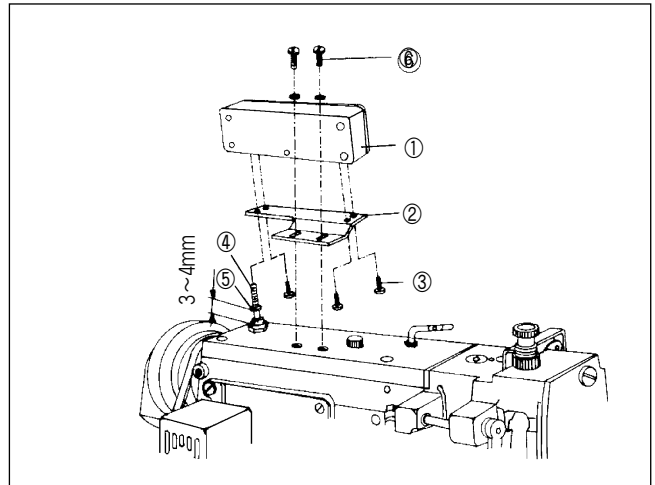

[Figure 8]

7) Installation of the thread stand

As can be seen in Figure 9, fix the thread stand ① to the table using the washers and nuts on the right.

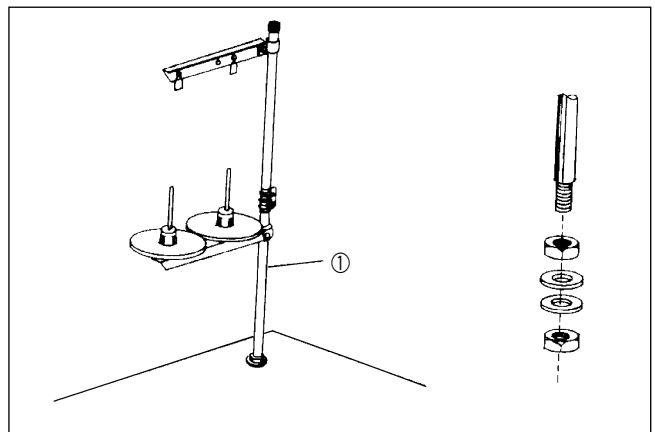

[Figure 9]

8) Assembly of the location detector and its control method (for automatic trimming type)

(1) Installation of the location detector

Assemble in the order of marked numbers as can be seen in Figure 10. Then, following Figure 11, make adjustments to place the photo film at the center of the sensor housing ①, by moving the shaft ② to the right and left. Then, tighten the 2 fixing screws ③ by using the hexagonal wrench ④.

[Note]

- A) As can be seen on Figure 10, make sure that the marks "DOWN" and "UP" face the front when looking from the pulley side.
- B) Film adjustment is completed upon shipment.

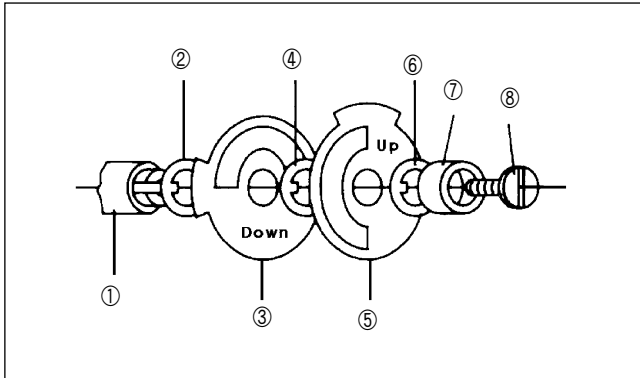

[Figure 10]

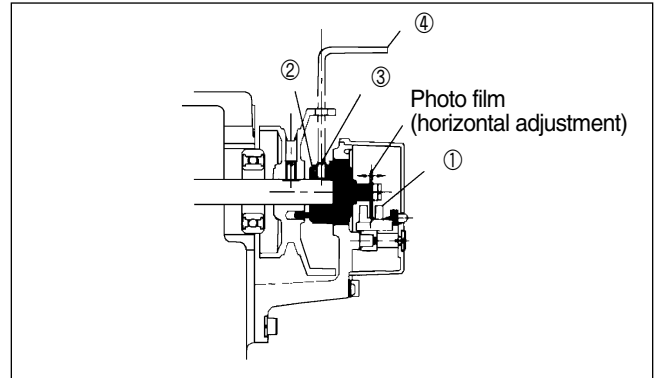

[Figure 11]

(2) Film adjustment of location detector

A) For new model type (see Figures 12, 13)

Manually turn the pulley so that the needle bar is placed where it starts rising from the lowest point. Unfasten the film-fixing screw ① in Figure 13, and for "DOWN" film A, align the film adjustment base line with the sensor adjustment base line, as can be seen in ㊦. Then, using the fixing screw ①, fasten the film only as tightly as to prevent it from turning. In the same way, place the thread-take-up lever at its highest point. Once again unfasten the fixed screw ①, and align the "UP" film B like ㊦. Now, be careful not to move the previously set "DOWN" film A.

B) For old model type (See Figure 14)

Adjust in the same way as for new model to make the right side ㊦ of the film's projecting part aligned to the center of the sensor base line.

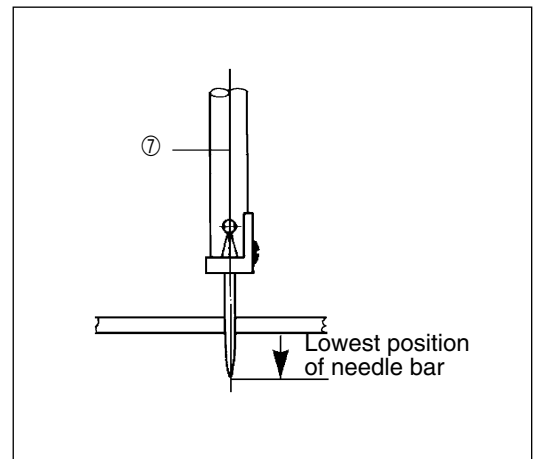

[Figure 12]

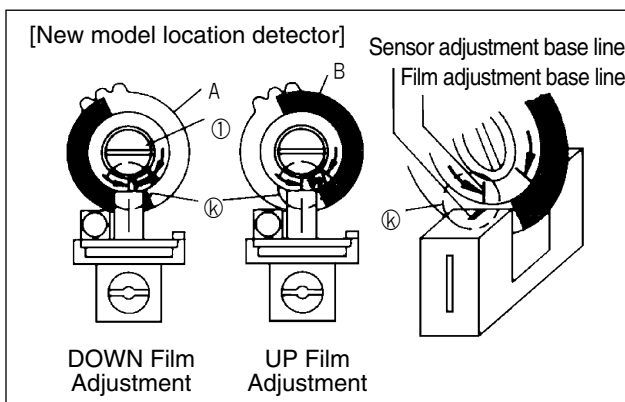

[Figure 13]

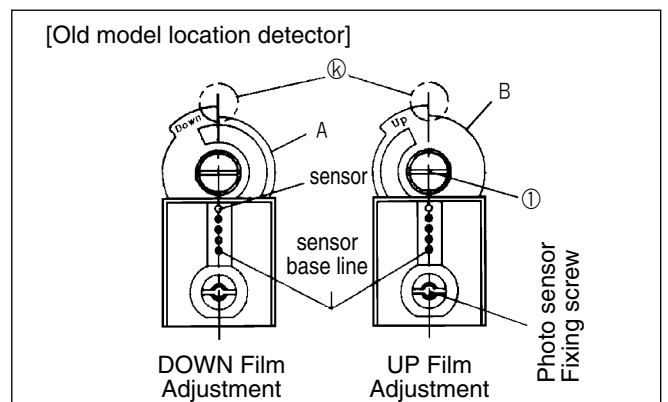

[Figure 14]

⚠ Caution



- ▶ Be sure to plug in after finishing oil supply.
If the user steps on the pedal by mistake, the machine will start automatically, and this might lead to physical injuries.
- ▶ When handling lubricant, use safety goggles or gloves to prevent the lubricant from coming into contact with the eyes or skin.
It can cause inflammation. And don't drink the lubricant. It can cause vomiting or diarrhea. Please keep it out of the reach of children.



- ▶ Make sure to supply oil when using it for the first time or after not using it for a long time.

9) Oil supply

(1) Oil tank check

Fill the oil tank only to the red maximum line ②.
(See figure 15)

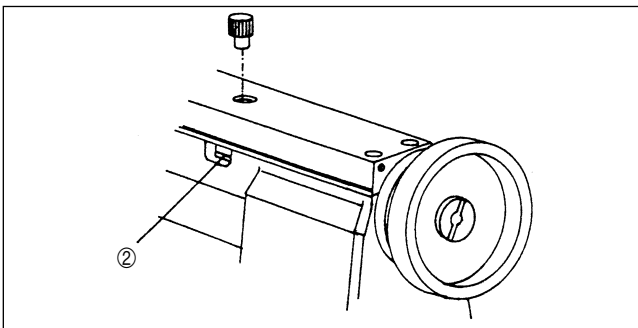

[Figure 15]

(2) Hook tank check

Fill the hook tank only to the maximum line. While using the machine, replenish the oil immediately when the oil level goes down to the minimum level ③, back to the red maximum level ①.
(See figure 16)

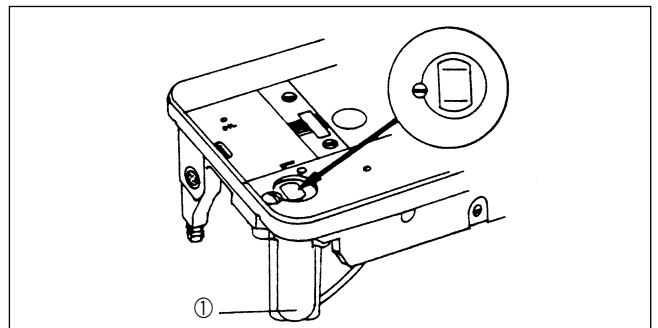

[Figure 16]

(3) Lubrication

Be sure to supply oil into the oil holes marked red and the oil holes in the friction parts before operating the machine.
(See figure 17)

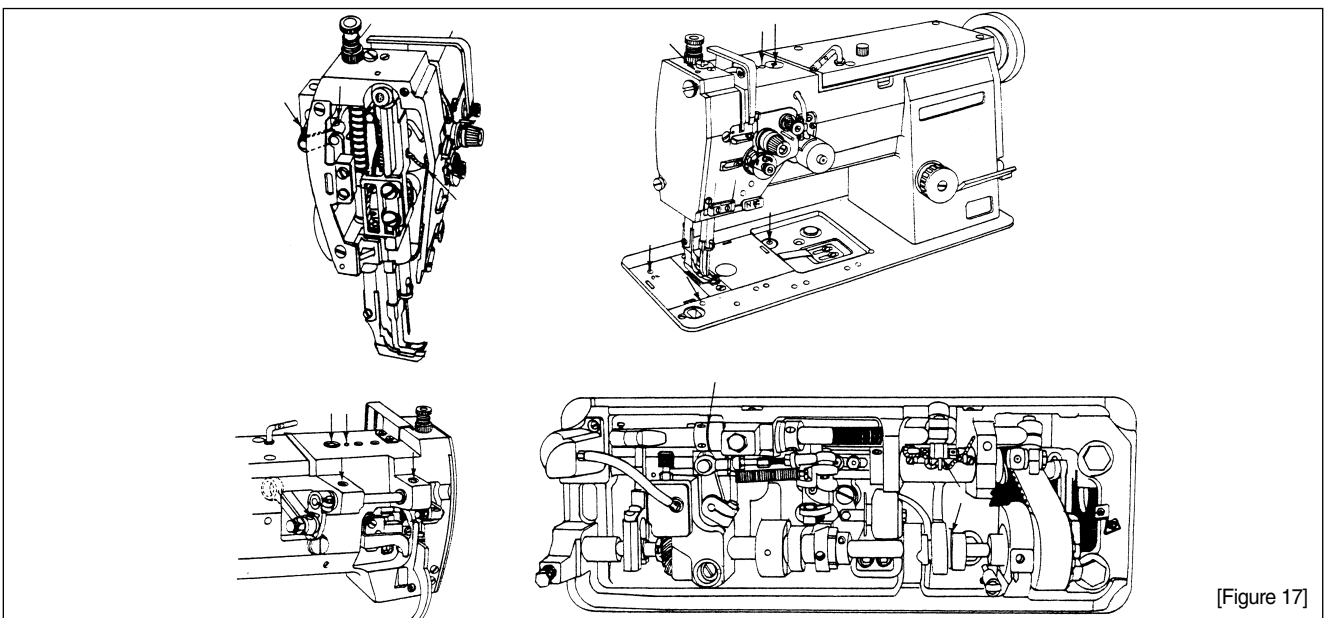

[Figure 17]

(4) Lubrication check at hook

After 10-second operation of the machine, check the amount of oil sprayed from the hook looks like the picture in Figure 18. The amount of oil for the hook can be adjusted by using the adjustment screw ① on the hook base. The amount of oil supplied decreases when the screw is turned clockwise, and increases when turned counter-clockwise.

(see figure 18)

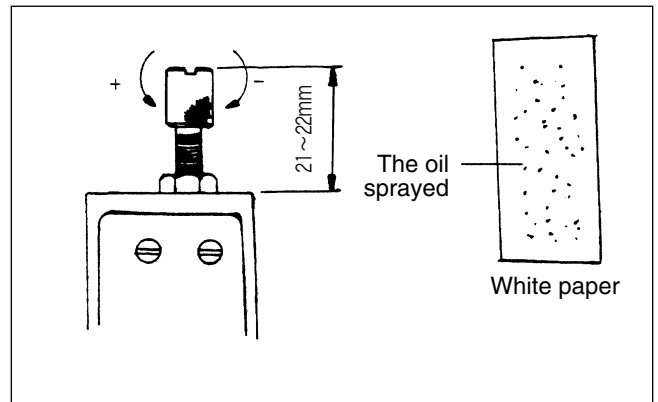

[Figure 18]

(5) For test operation, run the machine for 10 minutes intermittently at about 1,500 SPM.

For the first 4~5 days of using the machine, operate the machine at less than 2,400 SPM per minute. Then, start using at normal pace. This will help good performance of the machine along the way.

10) Checking stop position of the sewing machine (for automatic trimming type)

After changing the up-down position of the needle by pressing the reverse button, check the stop position of the machine.

Check whether the thread take-up lever is in the highest position when the needle is in up-stop position. When the stop position is incorrect, there might be problems to the trimming function, hence the photo film location of the location detector must be corrected. That is, the needle up-stop position is the same as the needle bar's stop position once the trimming action takes place. So there is no problem with the timing of the trimming action. (See Figure 19)

(See 'location detector adjustment' on page 12)

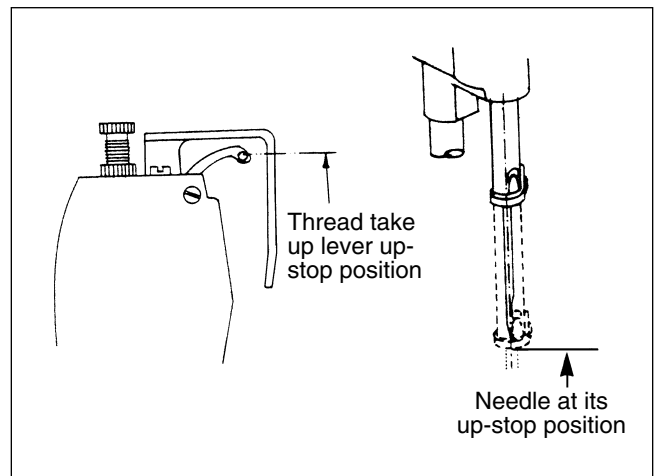

[Figure 19]

11) Reverse button function (for automatic trimming type)

If the reverse button ① is pressed while sewing forward, reverse sewing takes place immediately. If the machine is stopped first and the button is pressed before stepping the pedal to start the machine, reverse sewing will take place from the start. Also by pressing button while the machine is in stop position, the high-low position of the needle bar can be changed. If the button is pressed once when the needle bar is in down-stop position, the needle bar changes to up-stop position. Once again, if the button is pressed twice consecutively within 1 second, the needle bar changes to down-stop position.

That is, it has both the reverse sewing and needle up-down position change functions. (See Figure 20)

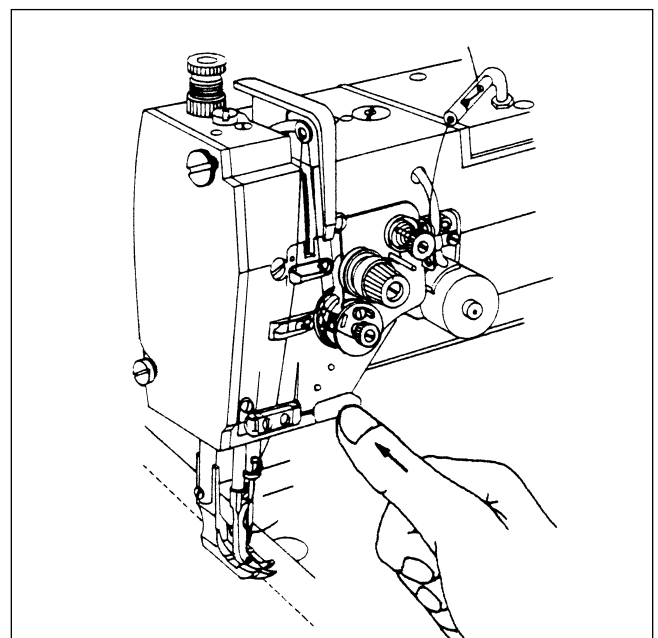

[Figure 20]

3

Adjustment of the Machine

Caution



- ▶ Always turn off the power when mounting a needle.
If the operator mistakenly steps on the pedal while the power is on, the machine will start automatically and can result in physical injuries.
- ▶ When using clutch motor, be aware that the motor will continue to rotate for a while even after the power is switched off due to inertia.
Start to work on the sewing machine only after the motor has come to a complete stop.

1) Inserting the needle

As in Figure 21, place the upper end of the needle closely adhered to the upper side of the stopper hole ②, with the needle groove ① facing left. Fix the needle with a fixing screw ③. (See Figure 21)

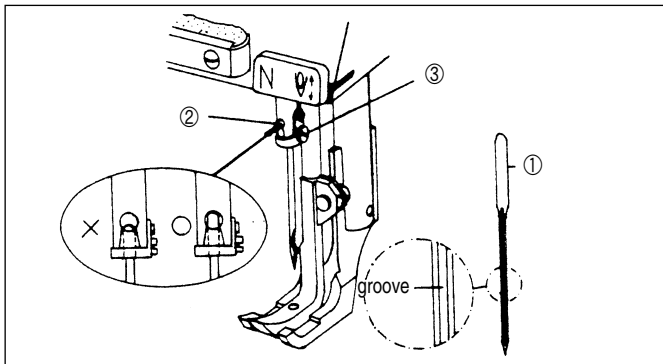

[Figure 21]

2) Removing bobbin

Place the needle ① in the highest position.

And then as in Figure 22, after pressing the slide plate stopper ⑤, open the slide plate ④ and lift the bobbin holder ⑦ to remove the bobbin ⑧. (See Figure 22)

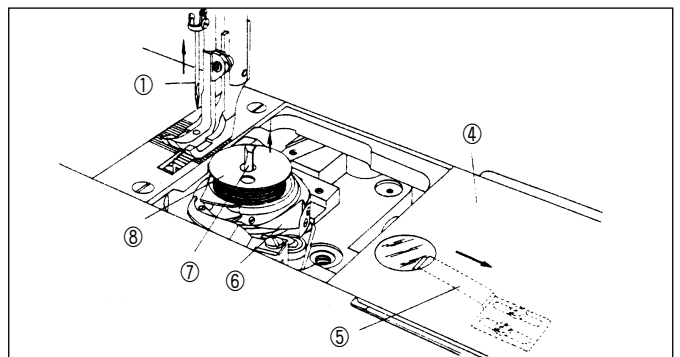

[Figure 22]

Caution



- ▶ Turn off the power when adjusting the lower thread tension.
If the operator mistakenly steps on the pedal, the machine will start automatically and can cause physical injuries.
- ▶ When using the clutch motor, be aware that the motor will continue to rotate for a while after the power is switched off due to inertia.
Start to work only after the motor has come to a complete stop.

3) Winding the lower thread

Insert the bobbin ⑧ into the hook ⑥. As seen in Figure 23, insert the thread through ① part of the hook and pull it out from the end of the lower thread tension adjustment plate ⑨. And then pull the thread through the clearance ⑩ between the hook ⑥ and opener ⑩. The adequate length of the pulled-out lower thread on the slide plate ④ is 50 mm.

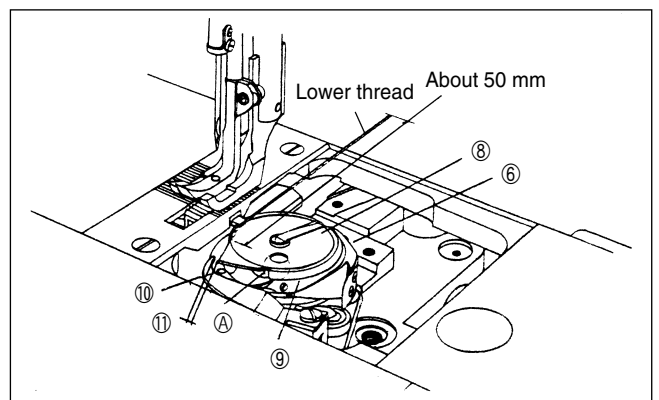

[Figure 23]

Caution



- ▶ Turn off the power switch when routing the upper thread.
If the operator mistakenly steps on the pedal while switched on, the machine will start automatically and can cause physical injuries.
- ▶ When using the clutch motor, be aware that the motor will continue to rotate for a while after the power is switched off due to inertia.
Start to work on the sewing machine only after the motor has come to a complete stop.

4) Routing the upper thread

Place the thread take-up lever to the highest position and hang the upper thread as in Figure 24.

- ※ The adequate length of upper thread extending from the needle hole is 50 mm for initial sewing.

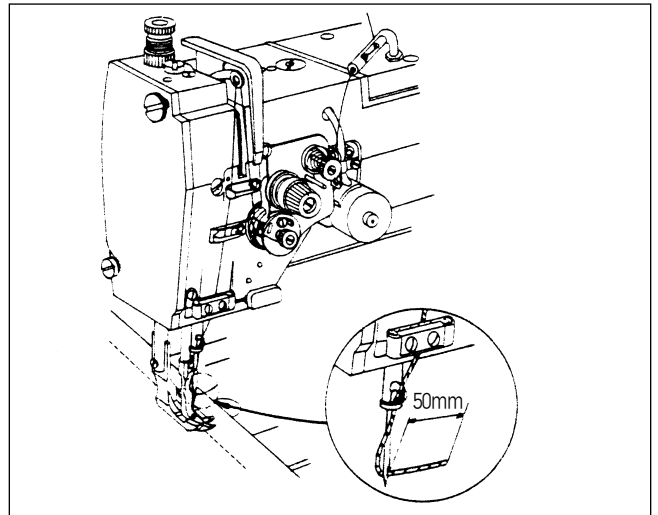

[Figure 24]

5) Adjusting the thread tension

(1) Adjusting the thread tension

As in Figure 25, turning clockwise the tension adjustment nut ① of the thread tension control assembly makes the upper thread tension stronger and counter clockwise makes it weaker.

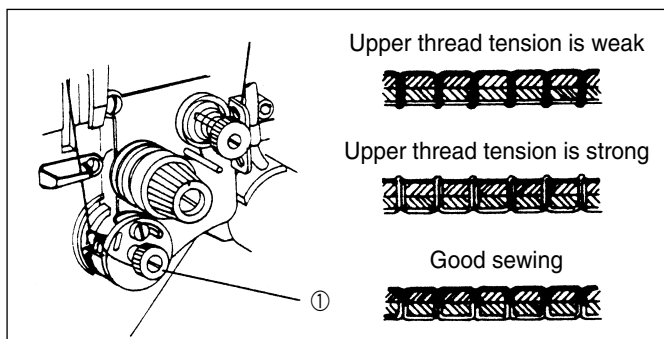

[Figure 25]

(2) Adjusting the lower thread tension

As in Figure 26, turning the tension adjustment screw ② of the hook clockwise makes the lower thread tension stronger and counterclockwise makes it weaker.

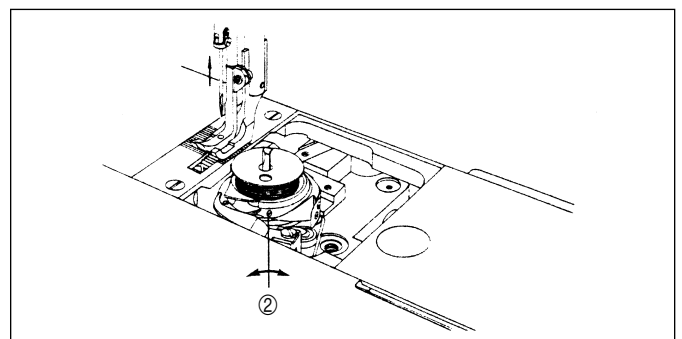

[Figure 26]

(3) Adjusting the tension of thread take up lever spring

A) Adjusting the thread take up stroke

As in figure 27, loosen the stopper clamp screw ⑥, and turn the thread take up lever's spring stopper ④ clockwise to make the stroke smaller and counter clockwise to make it bigger.

※ The thread take up stroke is normally 10~14 mm.

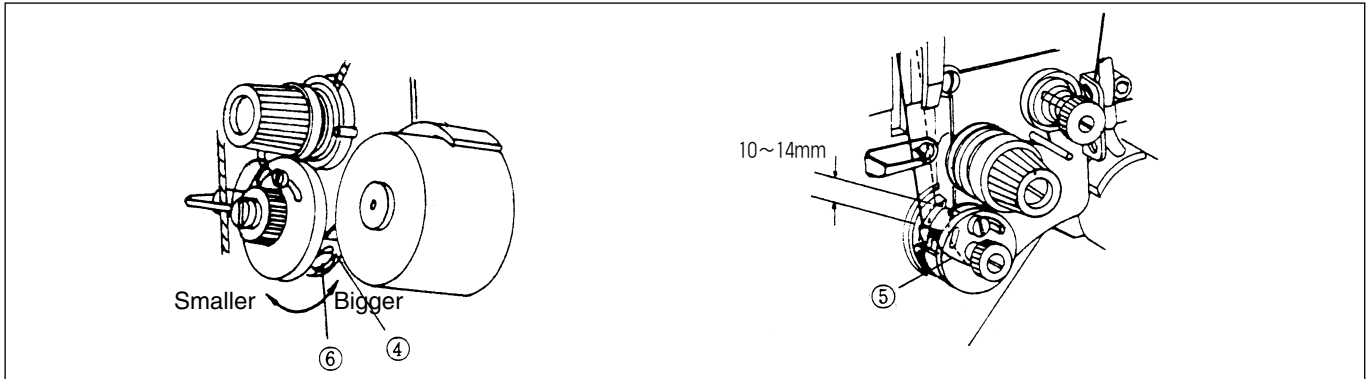

[Figure 27]

B) Adjusting the thread take up tension

As in figure 28, loosen the screw ⑥ of the thread tension control assembly, and insert the driver into the groove of the thread tension control assembly ⑦. Turn clockwise to make the spring ⑤ tension stronger and counter clockwise to make it weaker. (See Figure 28)

C) Adjusting the timing of the thread take up spring tension

As in Figure 29, loosen the stopper screw ③, and turn clockwise the guide plate ⑧ for the thread take up spring to make the timing of the spring ⑤ faster and counter clockwise to make it slower.

※ The timing of the thread take up spring tension is normal, when the guide plate is located in the middle as can be seen in Figure 29.

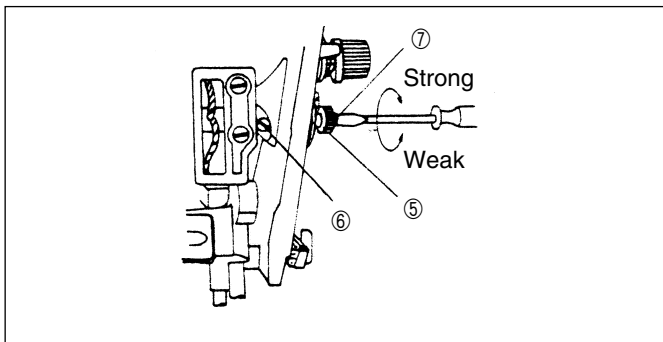

[Figure 28]

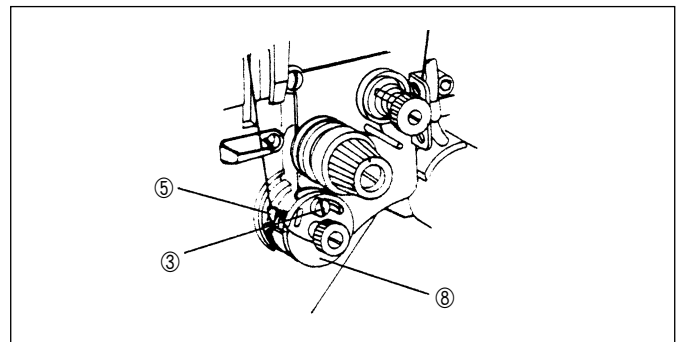

[Figure 29]

D) Adjusting the auxiliary thread tension control assembly (for automatic trimming type)

As in Figure 30, when the auxiliary thread tension adjustment nut ⑨ is turned clockwise, the length of the thread after trimming is short. The other way makes the thread long.

※ The appropriate length of the upper thread on the needle after trimming is 35~45 mm.

※ This can also be done by using the remaining upper thread length adjustment volume of the control box.

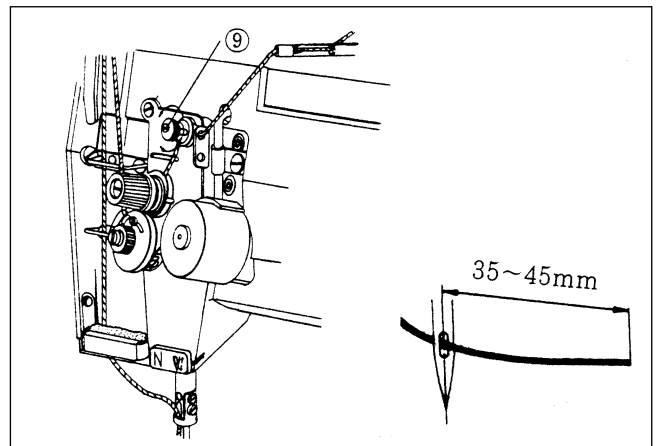

[Figure 30]

Caution



- ▶ After disassembling and adjusting a safety device, always place it back to the original position and check whether it functions as intended.
- ▶ Use both hands when pushing the machine backward or returning it to the original position. Due to the weight of the machine, your hand can get stuck in the machine if you should slip.
- ▶ When adjusting the machine with the switch on, be sure to pay extreme caution.



- ▶ Only trained engineers must perform troubleshooting or inspection of the machine.
- ▶ For electrical repair or inspection, consult with qualified technicians or agent.

6) Adjusting the tension of the presser foot

As in Figure 31, turning the pressure adjustment screw ① clockwise makes the presser foot tension stronger, and turning counter clockwise makes it weaker.

After adjusting, make sure to tighten the fixing nut ②.

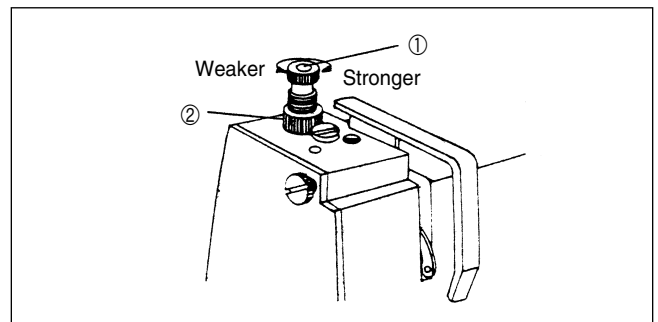

[Figure 31]

7) Adjusting the needle and feed dog timing

- (1) After removing the needle, lay down the machine on its back and remove the timing belt ①. Turn the pulley ② to coincide the ① highest point ⑥ of the thread take up marked on the pulley with the base point ⑦ marked on the arm ③. In this state, turn the timing (lower) pulley ④ to adjust the baseline ⑧ on the bed to the baseline ⑨ of the timing (lower) pulley. Then put the belt ③. (See Figure 32)

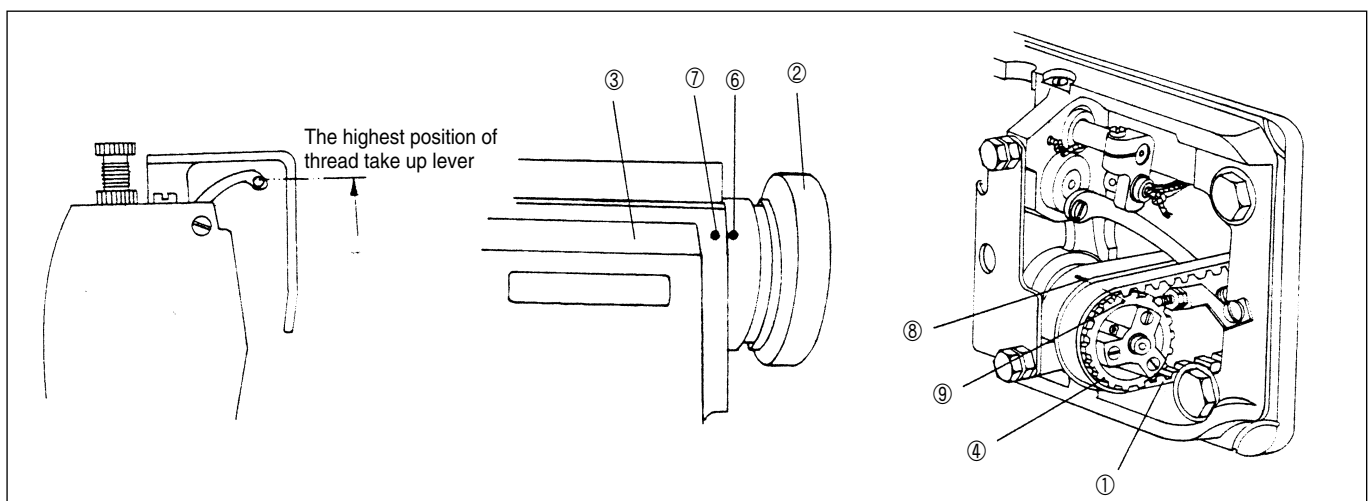

[Figure 32]

- (2) As in Figure 33, check whether the needle tip matches the upper side of the needle plate at the moment when the upper side of the feed dog ① and the upper side of the needle plate ② match each other.

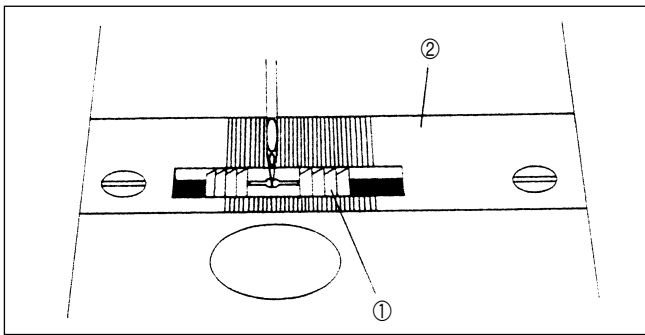

[Figure 33]

8) Adjusting the position of the feed dog

- (1) Set the feed-adjusting dial at "0", loosen the clamp screws of the vertical roller crank ③ and the needle bar shake crank ④. Adjust the needle hole of the feed dog ① to be placed about 1.5 mm before the center of the hook and then fasten it firmly. (See Figure 34)

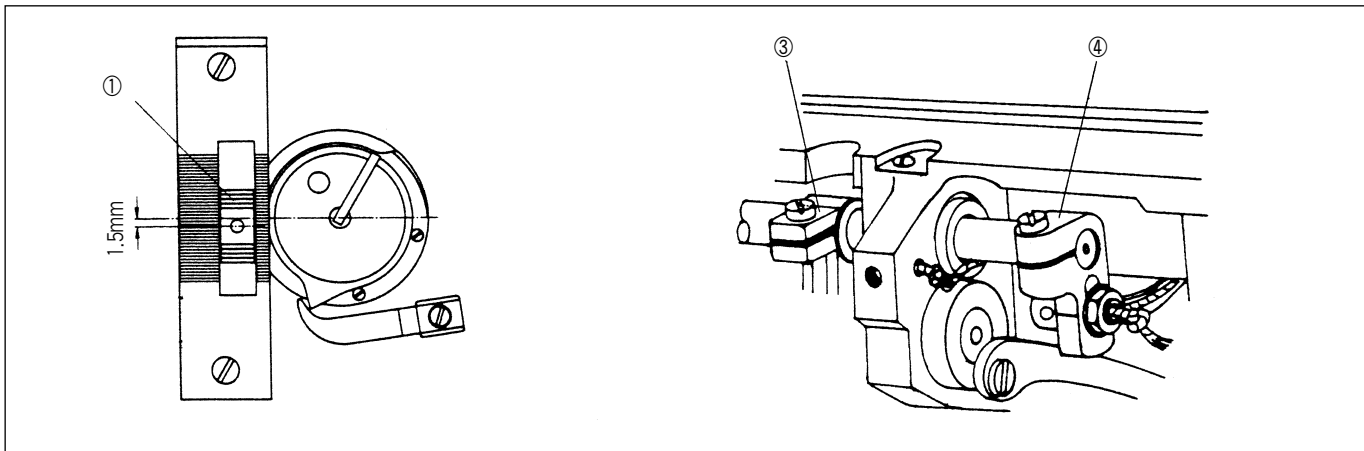

[Figure 34]

- (2) Turn the pulley for the needle bar to be at its highest position.
(See Figure 35)
- (3) Check whether the needle is bent. If it is, the needle should be replaced.
- (4) Turn the pulley slowly to check whether the needle's edge falls exactly at the center of the needle hole of the feed dog.
(※ If not, take the following steps.)
- A) Open the back cover and loosen the clamp screw ⑤, as can be seen in Figure 35.
- B) Move minutely the needle bar frame ⑥ to match the needle's edge with the center of the needle hole.
- C) After adjustment, fasten the clamp screw ⑤ firmly.

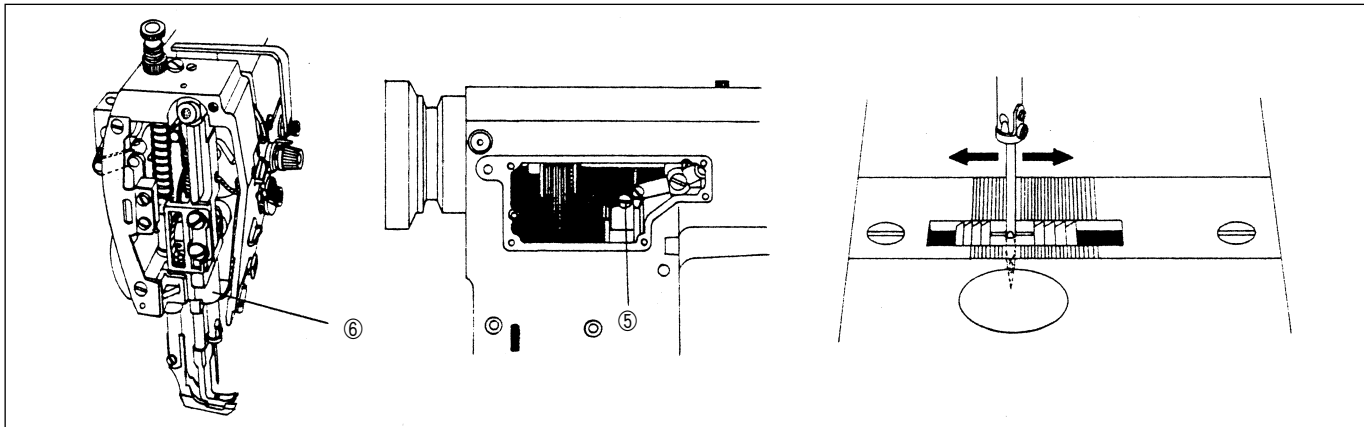

[Figure 35]

9) Adjusting timing of needle and hook

(1) Fixing the height of the needle bar

- ※ Turn the pulley to make the needle bar be placed in its lowest position. Loosen the needle bar holding screw ① in Figure 37 to make sure that the needle bar carved sign ② meets the end ③ of the frame, then tighten the screw.

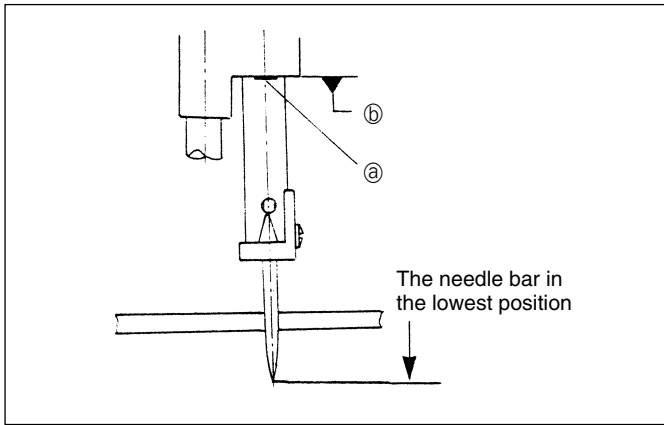

[Figure 36]

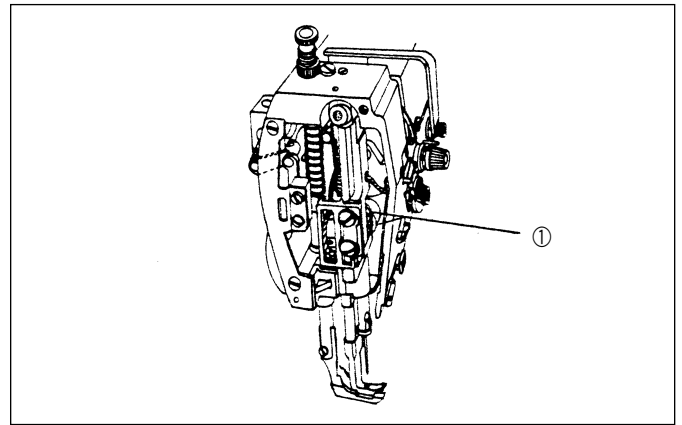

[Figure 37]

(2) Adjusting the timing of hook edge and needle center crossing

- First, set the stitch length at "0". Adjust the hook gear clamp screw ① in Figure 39 so that the hook edge fall exactly at the center of the needle center when the needle bar is raised 2.4 mm from its lowest position as in Figure 38. When this is done, the hook edge will be placed at about 1.5 mm above from the front of the needle thread hole.

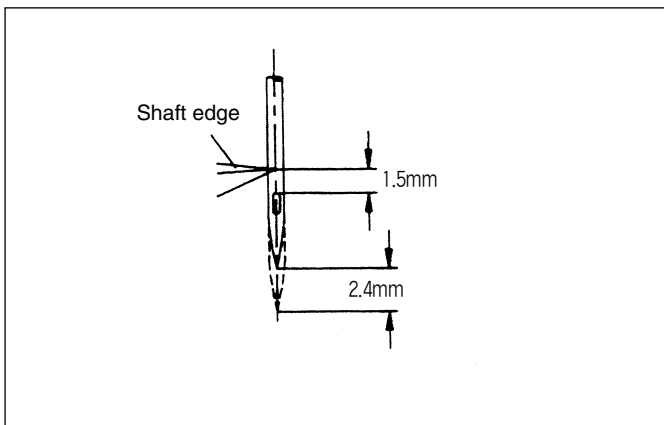

[Figure 38]

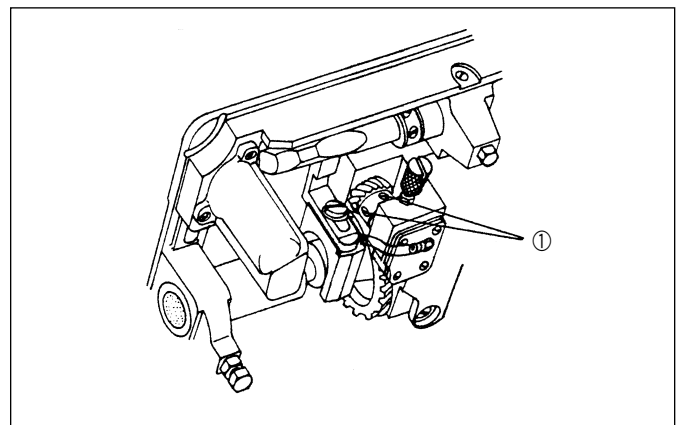

[Figure 39]

(3) Adjusting the distance between the needle and the hook edge

Raise the needle from its lowest point so that the hook edge meets the needle center. As in Figure 40, when the lower part of the needle meets the balance point of the hook's needle guide plate ① (adjust the needle guide form), adjust the distance between the hook edge and the inner side of the needle groove to 0.05~0.1 mm. Loosen ①, ② and ③ in Figure 41 and move the hook base ④ to the left and right for adjustment. (After adjustment, fasten ①, ② and ③ firmly.)

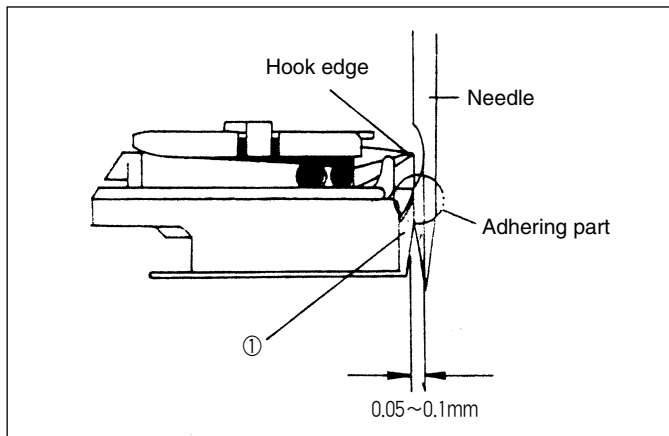

[Figure 40]

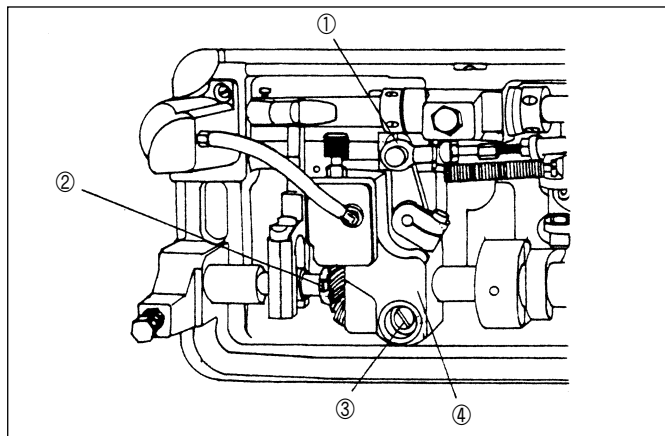

[Figure 41]

10) Clearance adjustment between the upper side of hook stopper and the upper side of needle board groove

Like in figure 42, the normal distance between the upper side of the hook stopper and the upper side of the needle plate groove is 1.2 mm. This distance can be adjusted by using the up and down adjustment of the bushing ② assembled under the hook ①. It can be adjusted by loosening ③ and ④. After adjustment, they should be fastened firmly. When this is done, make sure that the hook shaft gear ⑤ moves smoothly without moving up and down.

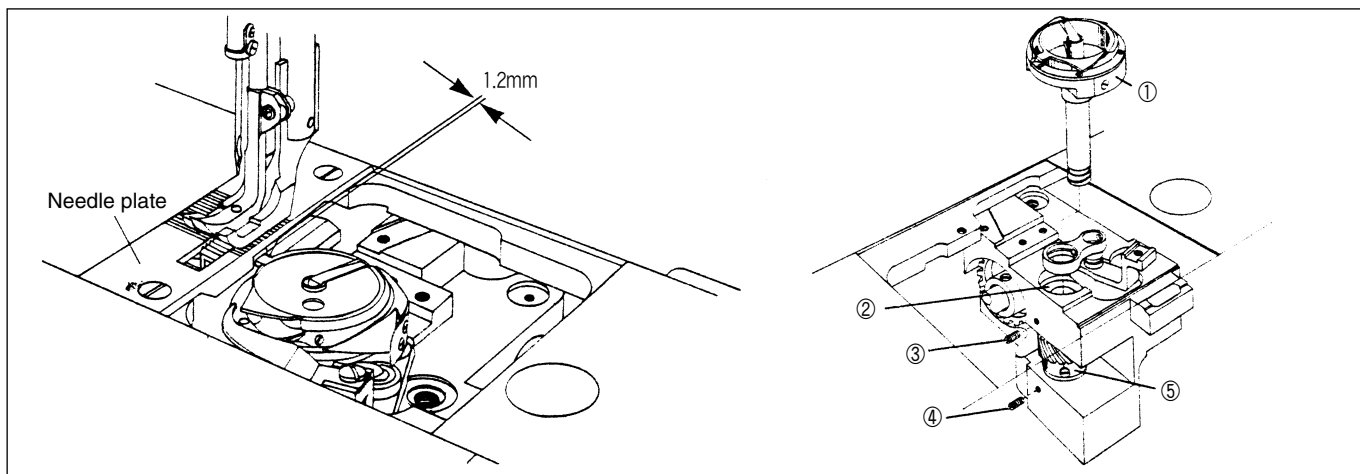

[Figure 42]

11) Clearance adjustment between hook and opener

Loosen the opener clamp screw ③ and turn the opener ② to the right and left so that the distance between the hook ① and the opener ② is about 0.2mm as in Figure 43 when the opener ② is pulled to its max towards the arrowed direction.

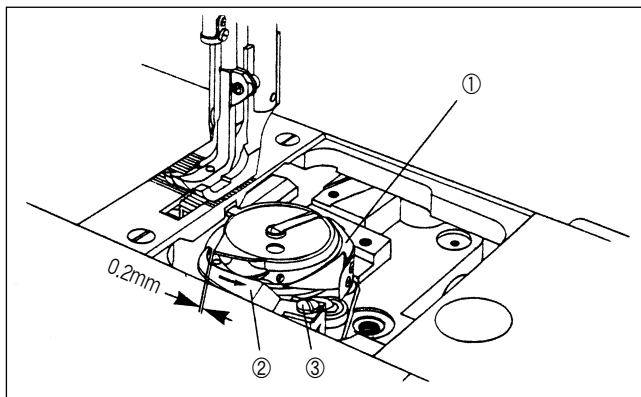

[Figure 43]

12) Adjusting feed dog height

Turn the pulley so that the feed dog ① is positioned at its high to adjust the feed dog ①. Loosen the fork clamp screw ④ of the feed dog base as in Figure 44 and move the feed dog base up and down so that the feed dog protrudes about 1 mm from the needle plate top. After adjustment, fasten the clamp screw firmly.

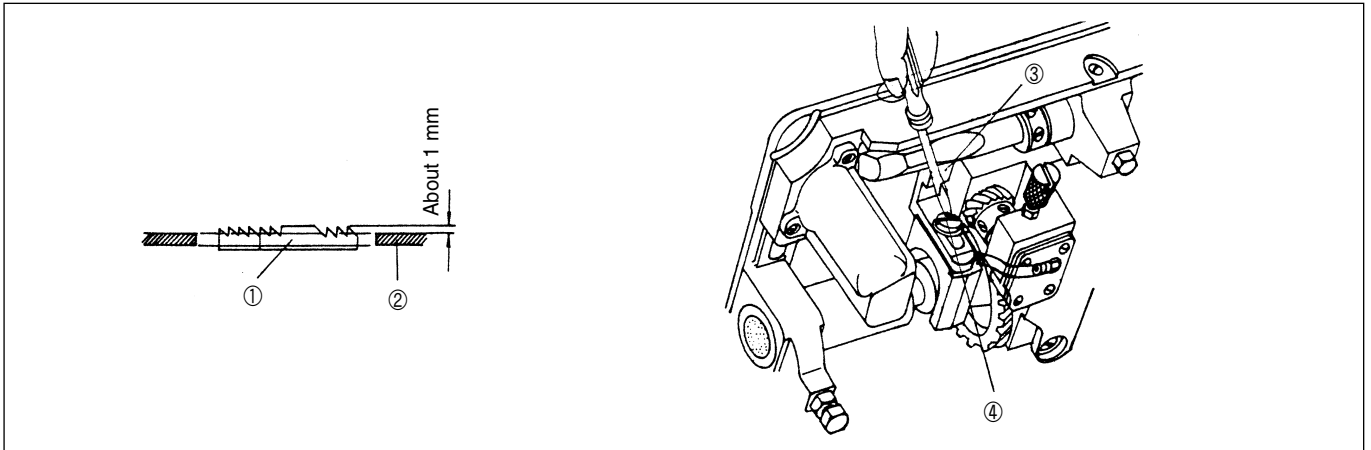

[Figure 44]

13) Adjusting the auxiliary presser foot and the upper feed presser foot

- ※ Both the auxiliary presser foot and the upper feed presser foot move up and down.
- ※ It is normal that both of them move up and down to the same height.
- ※ Take the following steps either to adjust the stroke of both to be the same or to make one of the two adjusted lower or higher, depending on sewing materials.

(1) Adjusting the strokes of both to be the same

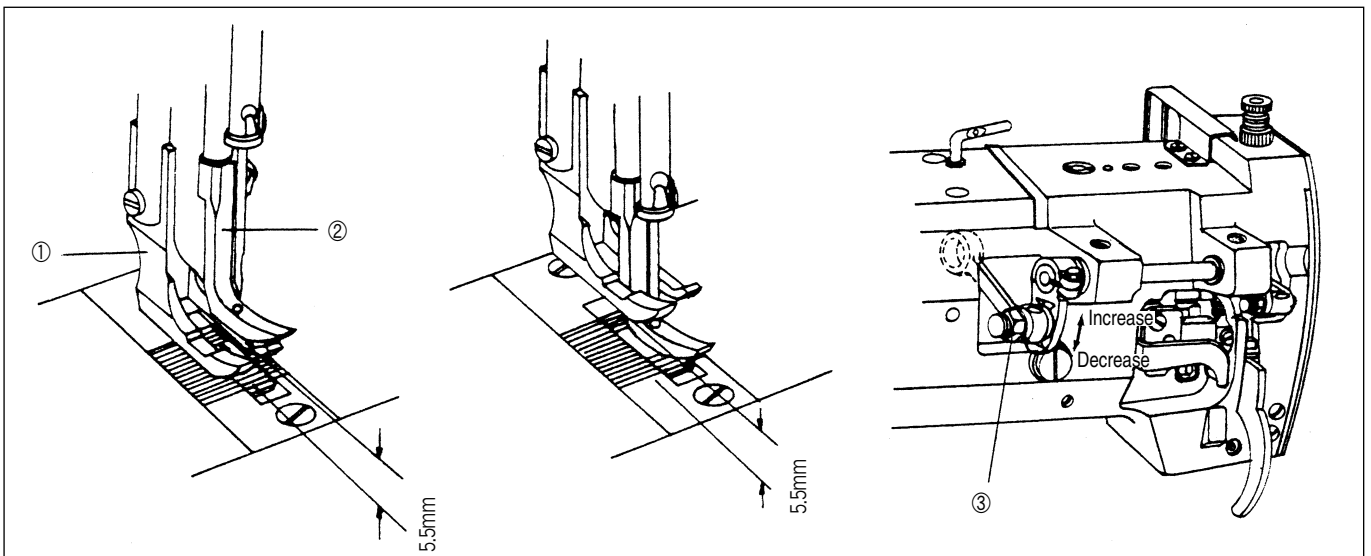

[Figure 45]

- A) The maximum height of the auxiliary presser foot ① and the upper feed ② presser foot is up to 5.5 mm.
- B) Loosen the nut ③.
- C) Move the nut ③ up or down, depending on sewing materials. Move it up to make the stroke increased or down to make it decreased.
- D) After adjustment, check the timing adjustment explained in ④, page 24.

(2) Adjusting the height of the strokes of both different

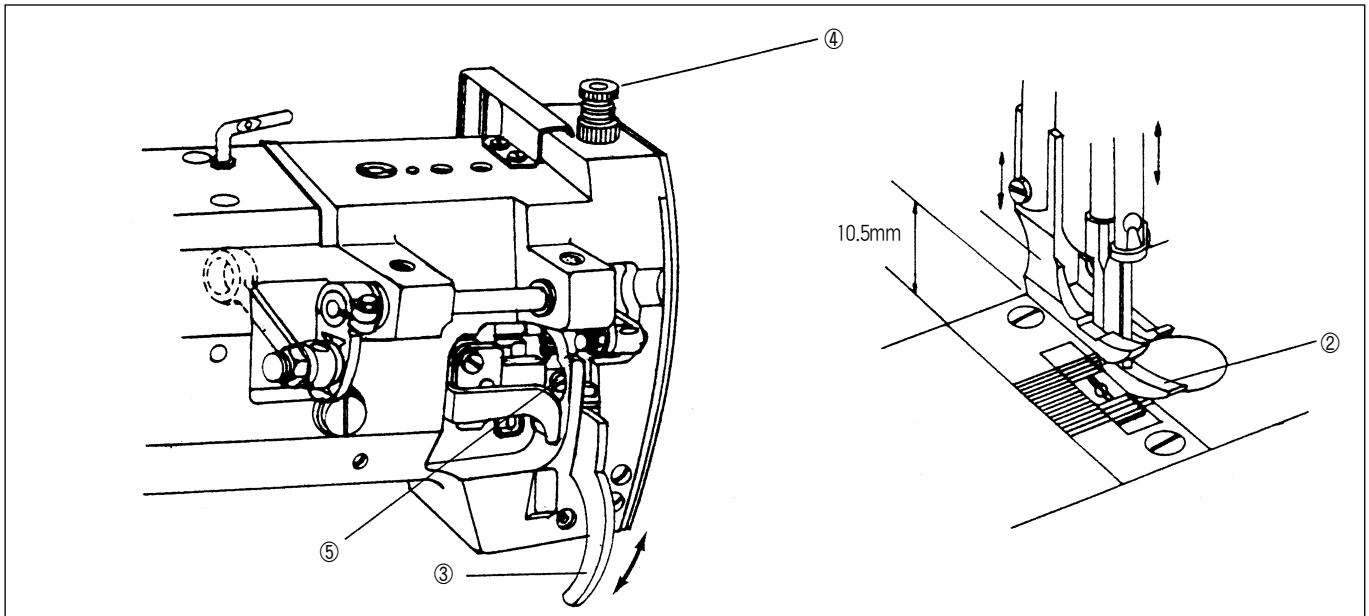

[Figure 46]

A) Adjusting the auxiliary presser foot

- ※ Loosen the pressure-adjusting screw ④ and the bracket-fastening screw ⑤.
- ※ Adjust the bracket-fastening screw ⑤ so that the auxiliary presser foot ① rise about 10.5 mm from the needle plate top when the pressure lifter ③ is raised.
(After adjustment, be sure to fasten the bracket-fastening screw first, and then adjust the pressure-adjusting screw.)
- ※ After the adjustment of the height of the auxiliary presser foot ①, adjust the upper feed presser foot ②.

B) Adjusting the upper feed presser foot

- ※ Loosen up and down crank clamp screw ⑥ when the pressure lifter ③ is down.
- ※ Move the needle bar close to its highest position.
- ※ Adjust the height of the upper feed presser foot ② to the sewing materials.
- ※ When the height of the upper feed presser foot ② is determined, be sure to fasten the crank clamp screw ⑥ and check the adjusting timing explained in 14), on page 24.

14) Adjusting timing of the auxiliary presser foot, the upper feed foot and the needle

When the needle ① goes down, the upper feed presser foot ③ should adhere to the feed dog ② before the needle edge adheres to the upper part of the feed dog ②. The upper feed presser foot ③ should continue to adhere to the feed dog ② even when the needle ① edge, going up, and the upper part of the feed dog ② are detached with each other. If not, loosen the two up-and-down cam ⑤ clamp screws ④ to adjust right and left the fixed position of the up-and-down cam ⑤ of the presser foot. (See Figure 47)

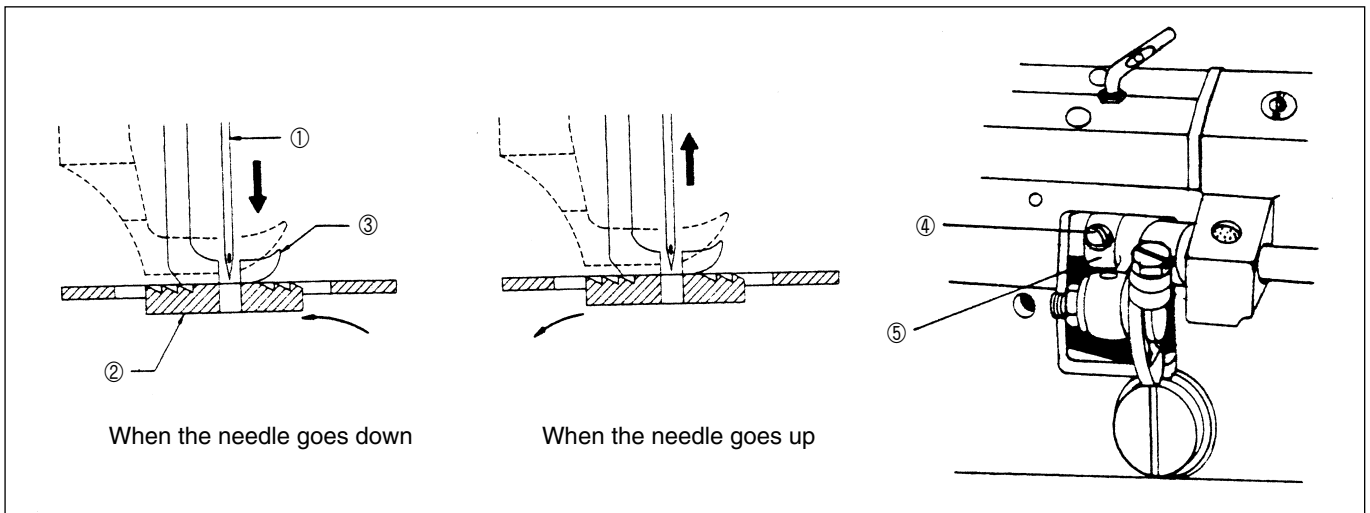

[Figure 47]

15) Adjusting stroke of upper feed presser foot

- (1) As in Figure 48, the machine is adjusted to have the same amount of upper feed presser foot stroke ④ as the feed dog stroke ⑤. (The baseline ⑥ of the shake crank ③ is aligned with the baseline ⑦ of the collar.)
- (2) Take the followings steps, if the two base lines are not aligned or if it is necessary to adjust the stroke ④ of the upper feed presser foot to increase or decrease.

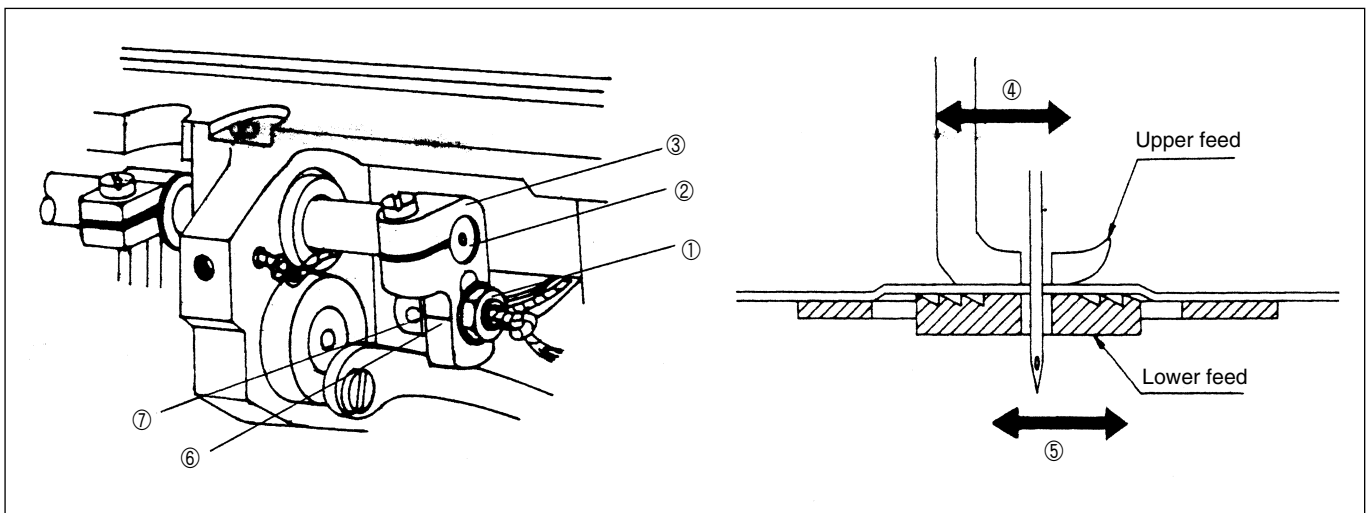

[Figure 48]

- A) Loosen nut ①.
- B) Move nut ① to the back ② of the horizontal roller to increase the stroke ④ of the upper feed presser foot. Move nut ① to the front ③ of the shake crank to decrease it.
- C) After adjustment, be sure to fasten nut ①.

16) Adjusting safety device

If the load occurs by foreign substances on thread, needle, etc, during the sewing operation, the driving ball of safety assembly in Figure 49 is removed to prevent damage of the hook and other major parts from the load, and the pulley ② and the clutch plate ③ on the safety assembly are removed. Then, the driving force of timing belt on the upper shaft does not delivered to the lower shaft, so only the pulley ② of safety assembly rotates idly. In case that the safety assembly starts operating during the work, turn power switch off and remove causing factors of load. Later, with safety button ④ pressed, turn the pulley to place the driving ball ① of safety assembly to its original position.

※ Adjust the intensity of the safety assembly spring ⑥ by rotating safety assembly adjustment screws ⑦ from side to side in accordance with working conditions. (Turning the screw to left makes the intensity stronger, and right to make it weaker. Make sure to give same pressure on the three screws.)

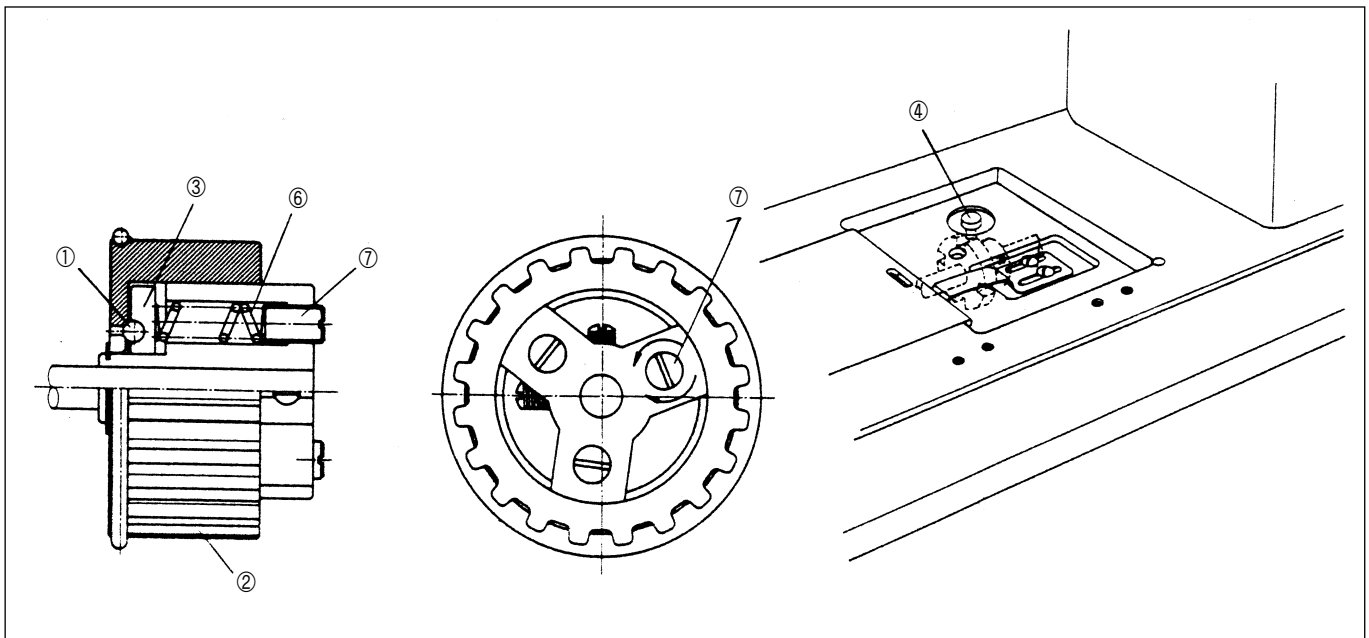

[Figure 49]

17) Adjusting the trimming device

(1) Adjusting the trimmer driving part

A) Fixing the position of the trimming cam (See figure 50)

- ① Turn the pulley manually to place the needle bar ⑦ at its lowest position.
- ② With the left side of the trimming cam ① softly attached to the right side of the lower shaft medium bushing ②, turn the cam to align the base point ③ with the carve ④ in the lower shaft medium bushing crank.
- ③ Fasten tightly the trimming cam fixing crews (3)
- ⑤. Now, turn the pulley manually to see whether or not the machine turns smoothly.

B) Adjusting the stopper pin holder (See Figure 51)

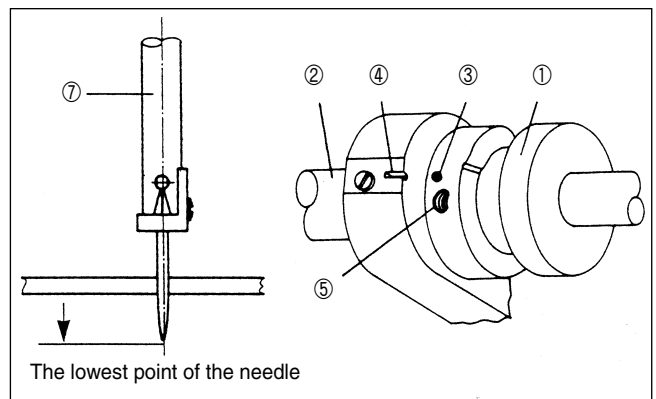

[Figure 50]

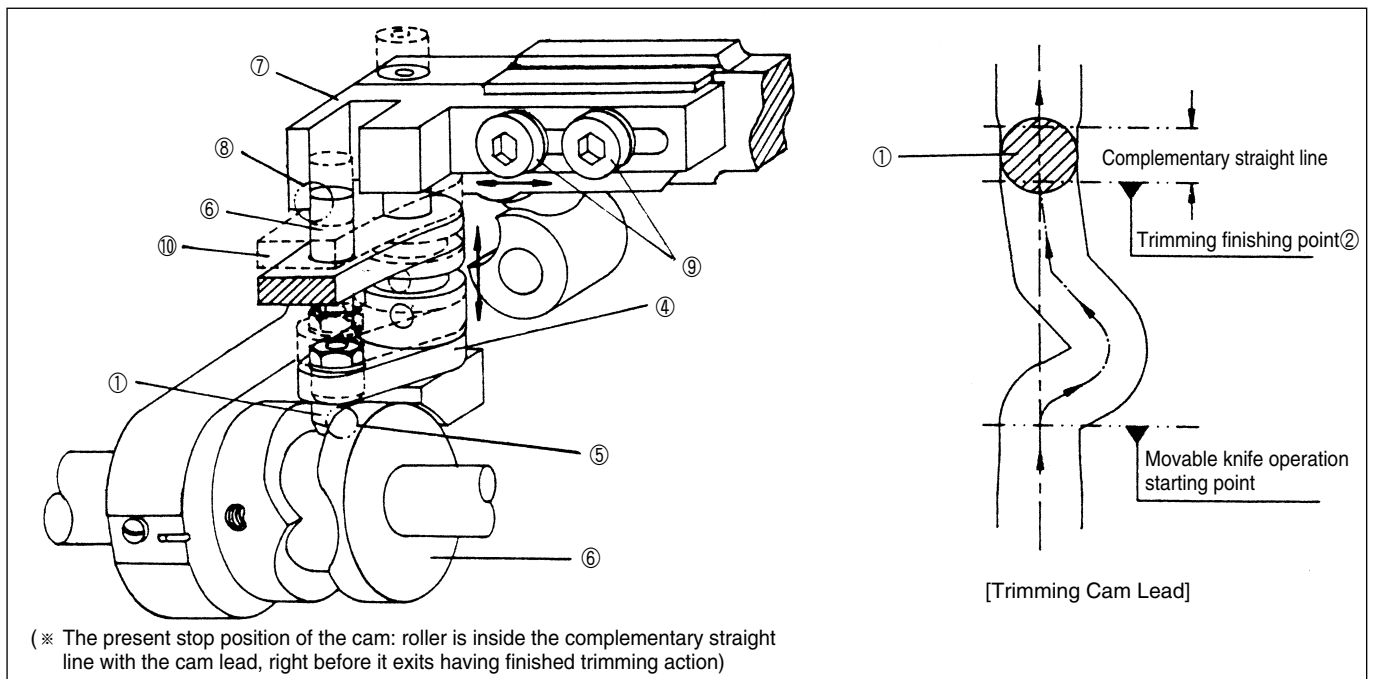

[Figure 51]

- ① Make sure to turn the machine pulley to place the trimming cam ③ in the right position, so that the roller ① can enter the complementary straight line ② range after finishing trimming marked in the trimming cam lead.
- ② Press down the trimmer shake linkage ④ to make the roller ① come inside the trimming cam,
 - ※ Adjust the holder ⑦ to make the right equal point of the roller ① adhere smoothly ⑧ to the inner right side of the cam's complementary straight line ②, and the left equal point of the stopper pin ⑥ adhere ⑧ smoothly to the inner left side of the stopper pin holder ⑦. Once this is done, tightly fasten the fixing screw ⑨.
 - ※ Once such adjustments are made, the trimmer shake linkage ④ will not move even when shaken to its sides (the roller is inside the cam). Make sure to check if the shake linkage ④ returns to up position ⑩ quickly and smoothly when released. If not, proceed with horizontal adjustment of stopper pin holder.

C) Fixing the position of the trimmer solenoid (See Figure 52)

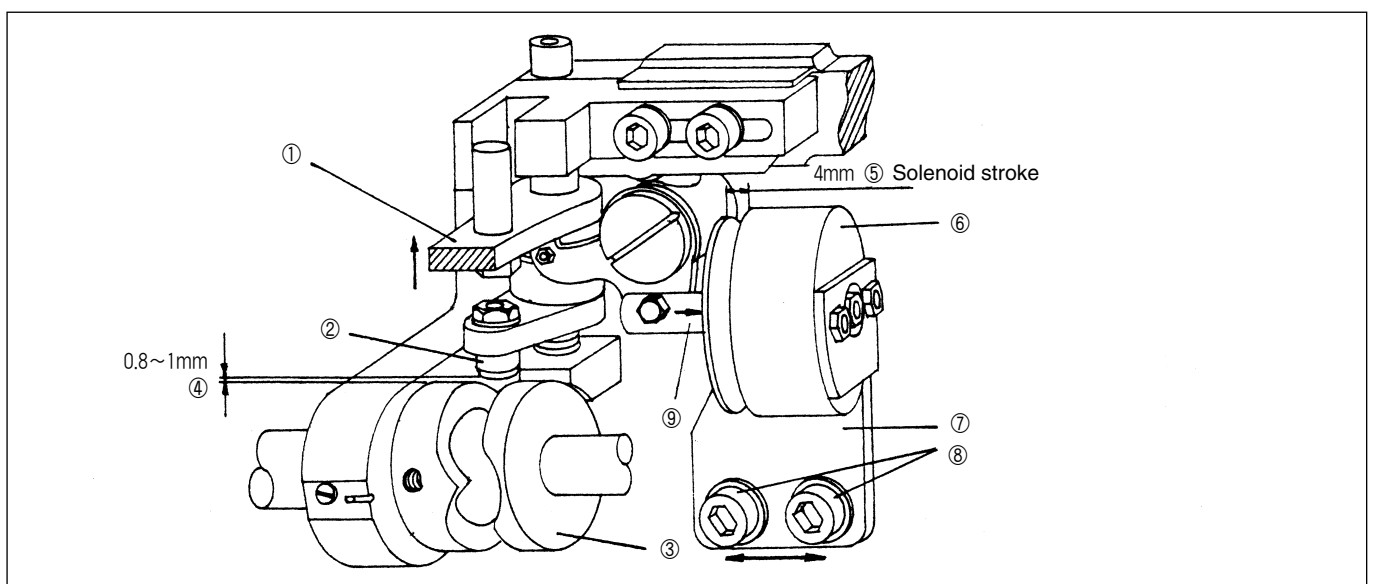

[Figure 52]

- ① When the whole trimmer shake linkage ① is in up position, that is, when it has come back to its original position after finishing trimming, the distance ④ between the lower part of the roller ② and the equal point of the trimming cam ③ is about 0.8~1mm. Assuming that this distance ④ never changes, adjust the position of solenoid bracket ⑦ horizontally, where the solenoid housing ⑥ is attached, to make the solenoid stroke ⑤ 4 mm. Then, tightly fasten with fixing screw ⑧.
- ② After adjusting the solenoid stroke ⑤, manually operate the solenoid shaft ⑨ towards the arrow direction. See whether it returns to its original position fast and smooth when released. If not, proceed with horizontal adjustment of the bracket ⑦ minutely up and down and right and left.

(2) Adjustment of linking device for movable knife shaft and the trimmer driving part

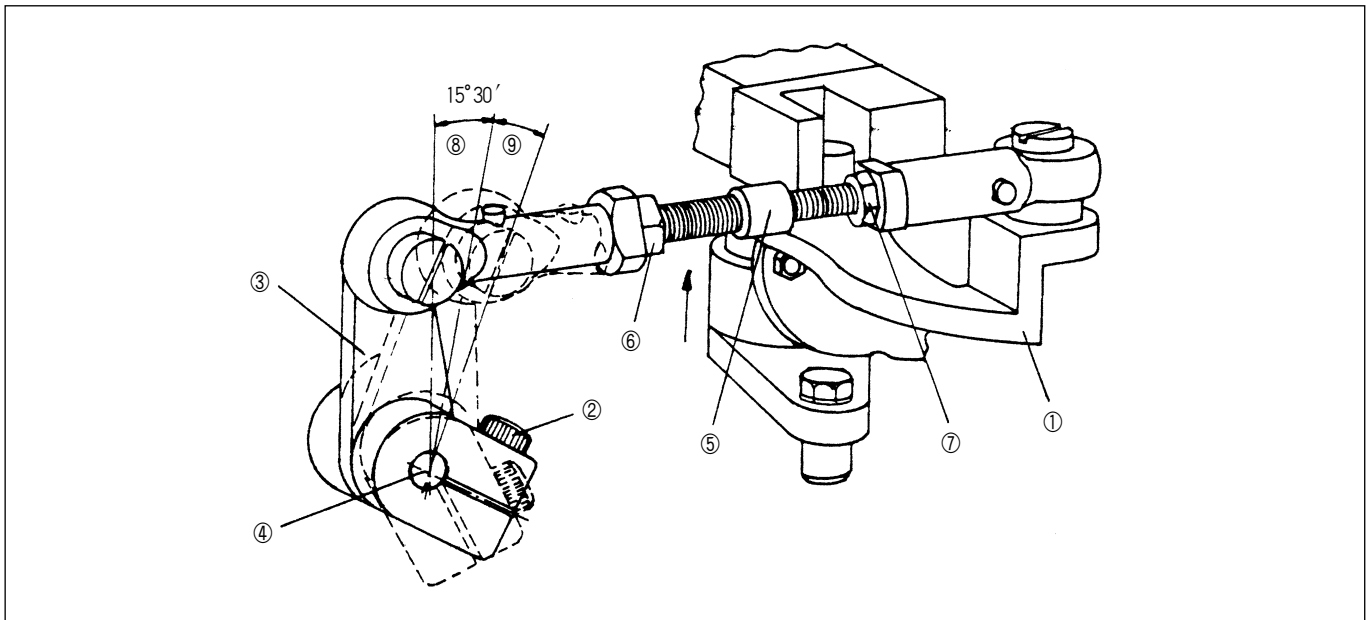

[Figure 53]

- A) When the previously explained adjustment of trimmer driving part is complete, it is in its normal position where the trimmer shake linkage ① has returned to its up position after trimming action.
- B) First, loosen the fixing screw ② of the movable knife shaft, hold the initial assembling angle of the crank ③ to be about 15° 30' to the left from the perpendicular line drawn to its center ④. To make sure that this position is maintained, adjust the length of the ball joint linking bar ⑤, and tightly fasten the fixing screw ② of the crank. (* For the adjustment of the ball joint linking bar ⑤, turn the linking bar ⑥ after loosening the nuts (left) ⑥ and (right) ⑦. Nut (left) is left screw and nut (right) is right screw.)
- C) When the linking device is connected as such, the movement angles of crank ③ during trimming movement results in an equal angle movements for left ⑧ and right ⑨. Hence, it can be said that the trimming movement is very light.

(3) Adjusting movable knife and fixed knife

A) Adjusting the position of movable knife-edge and hook stopper

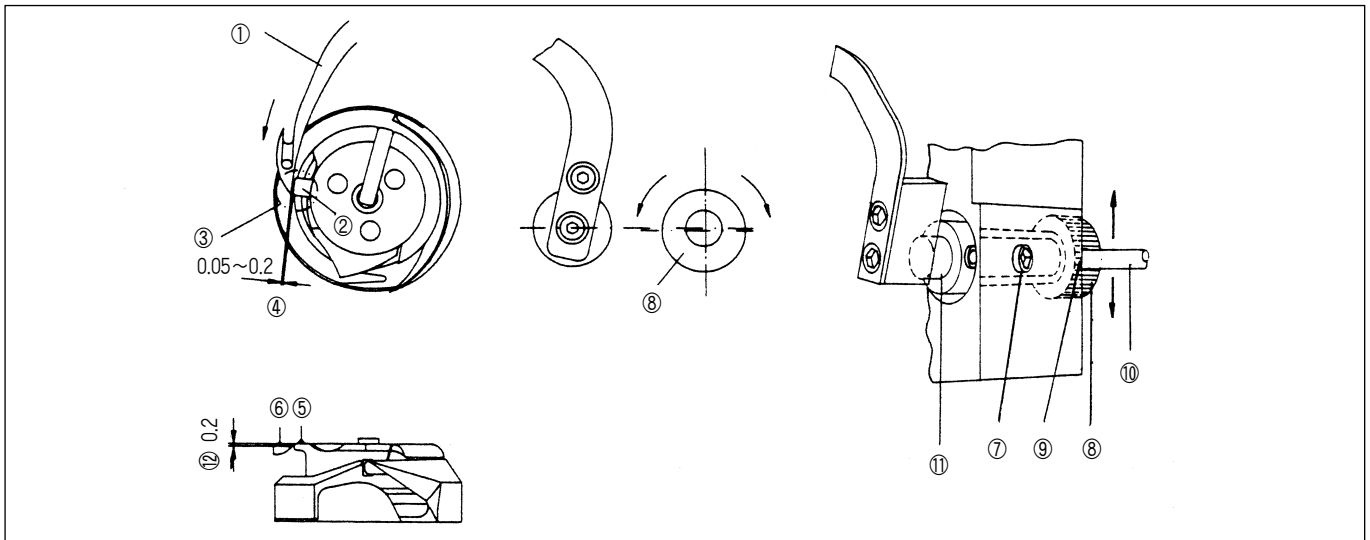

[Figure 54]

- ① When a movable knife ① passes the front side of the hook stopper ②, adjust the distance ④ to be within 0.05~0.2 mm range like part ③. The upper surface of the movable knife-edge ⑥ should be set up 0.2mm below the upper side of hook stopper ⑤. (* Given that the fixed knife is pressing down the movable knife.)
- ② Clearance adjustment of the movable knife edge and hook stopper front side
 - * Loosen the needle plate
 - * Place the hook stopper in the hanging position to the needle plate
 - * Holding the hook with the hand, manually operate trimming movement so that the movable knife-edge matches the stopper front side ③.
 - * Loosen the fixing screw ⑦ of the movable knife shaft eccentric bushing.
 - * In the lower side hole ⑨ of the eccentric bushing ⑧, stick in a thin driver or adequate pin ⑩ and turn right and left. This will make the position of the movable knife shaft ⑪ change, hence changing the distance ④.
 - * When the clearance adjustment is finished, tightly fasten the fixing screw ⑦ of the bushing.
- ③ The adjustment of crossing height ⑫ between the hook stopper upper side ⑤ and movable knife edge upper side ⑥ is possible to certain degree by adjusting the movable knife base washer ⑦ or by changing the position of movable knife shaft collar ⑧, as can be seen in Figure 55.

B) Adjusting movable and fixed knife

- ① As in Figure 55, adjust the position of the fixed knife ③ so that the fixed knife right side edge ② matches the movable knife inner side edge ①.
- ② The initial assembling position of the movable knife ④ is where the movable knife-edge protrudes about 3 mm from the edge of the fixed blade. Make sure to check the "final fixing of the movable knife initial position" on page 29.
- ③ The surface adhesion conditions ⑤ of fixed blade edge and movable knife upper side have huge impact on its trimming capacity. Please note the various cases of movable/fixed knife surface adhesion conditions on the picture.

(Correcting the adhesive conditions of movable and fixed knives)

※ As in Figure 55, operate manual trimming movement with color ink on the movable knife-edge. By checking the ink trace remaining on the movable knife, the surface adhesion condition of the movable/fixed knives can be tested.

※ If the surface adhesion is not very good (same method is used to adjust the tension of movable/fixed knives), please use the following methods: adjusting the amount and position of the washer ⑦ in the lower side of the movable knife base ⑥, horizontally adjusting the assembling position of movable knife shaft collar ⑧, and correcting the shape of fixed blade ⑨ setting position.

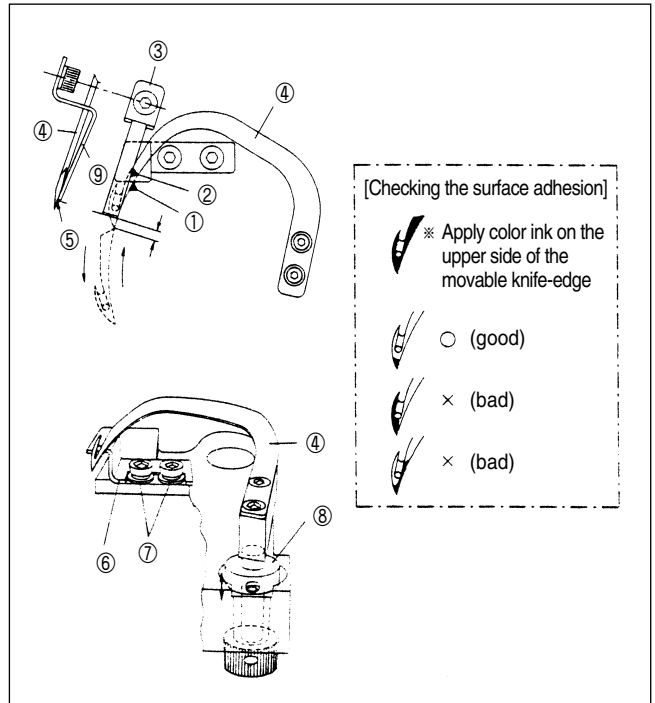

[Figure 55]

C) Final fixing of the movable knife's initial position

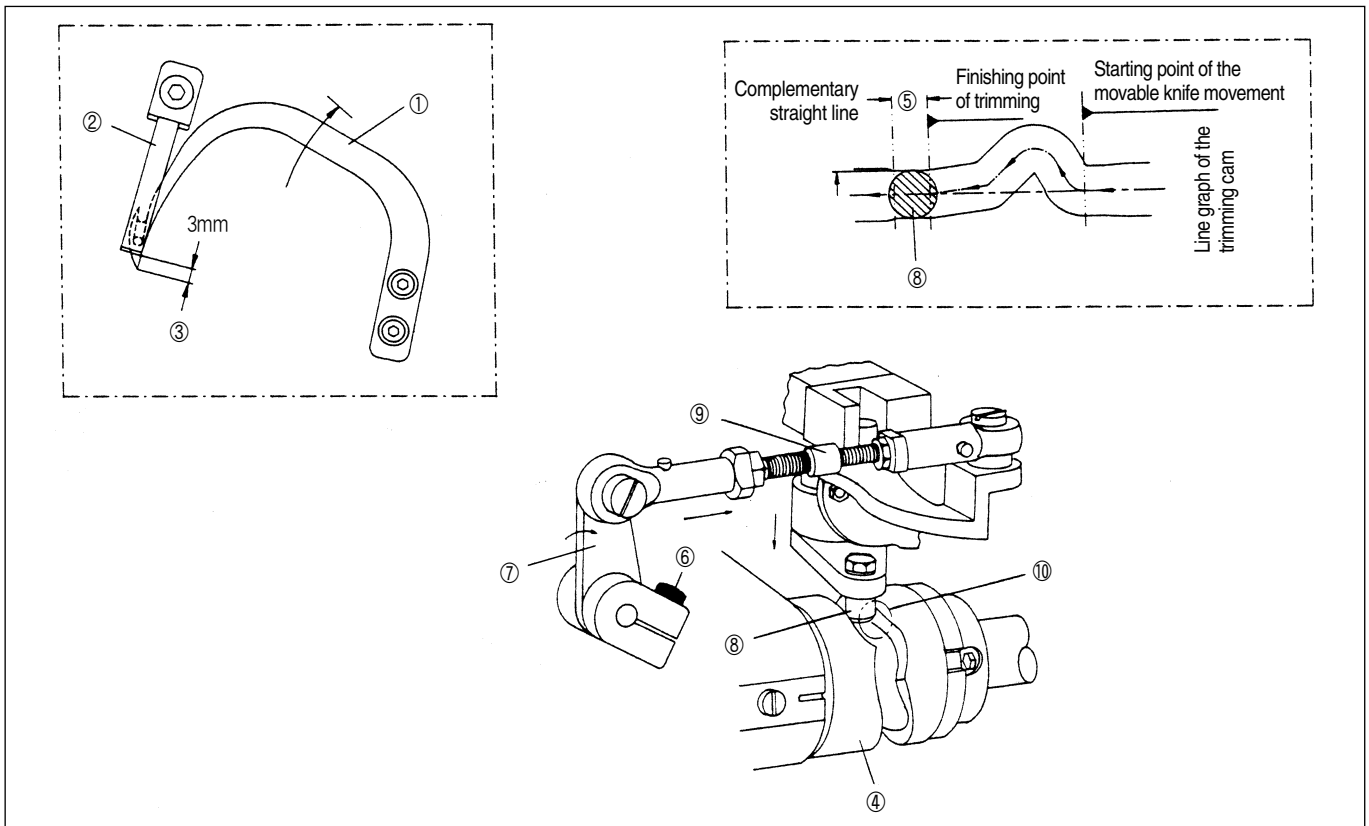

[Figure 56]

※ The standard initial assembling position of the movable knife ① is where the movable knife-edge protrudes about 3mm ③ from the fixed knife edge ② when the trimming action is finished, that is, when the movable knife is in its initial stop position. When fixing the position of the movable knife, the following directions must be followed so that the power generated in the cam ④ is delivered without any loss to the trimming action.

(Adjustment Order)

- ① Manually turn the pulley to finish trimming of the trimming cam ④. Place the cam so that the roller ⑧ can enter the complementary straight line ⑤.
- ② Slightly loosen the fixing screws ⑥ of movable knife shaft crank.
- ③ Press the trimmer shake linkage ⑦ to enter the roller ⑧ inside the cam. Push slightly the ball joint linking bar ⑨ to the right so that there is no excess room in each linking device. When this is done, the roller ⑧ adheres to the right side of the cam's complementary straight line ⑤, as can be seen in the picture ⑩. While maintaining this position, adjust the movable knives on the right and the left to protrude about 3mm from the fixed knife-edge ②. Now, tightly fasten the crank fixing screws ⑥.
- ④ If the initial position of the movable knives of both sides are to be adjusted slightly, use the ball joint linking bar ⑨.

D) Adjusting lower thread holder

※ The position of lower thread holder ① is set by fixed knife ② and bolt ③.

As in the picture, loosen the bolt ③ and place the lower thread holder ① edge at the lower side of the movable knife, about 8mm apart from the movable knife edge ⑤. Make sure to check that the right and left upper sides A and B of the lower thread holder is tightly adhered to the lower side of the movable knife.

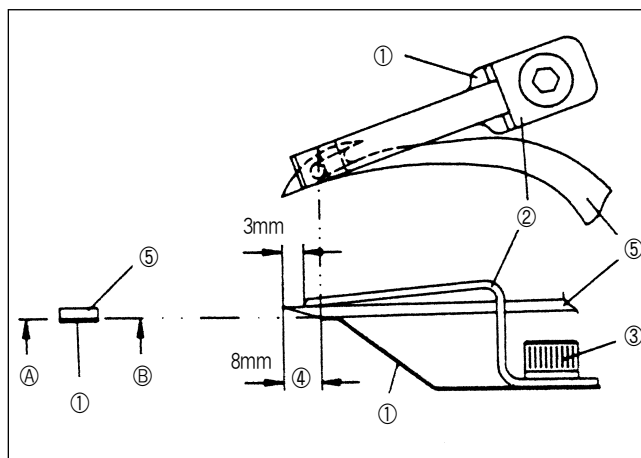

[Figure 57]

(4) Checkpoints on the assembling status of other trimming devices

A) Check the starting point of the movable knife when the trimming action takes place

Operate trimming movement manually to check whether the thread take up lever is in the lowest or at least 2.5 mm raised level when the movable knife starts working. (See Figure 58)

B) Maintenance of fixed knife

When the thread does not get trimmed or if the trimmed section of the thread is sloppy, please check the edge condition of the fixed knife.

If the edge of the knife is too dull, sharpen the edge using oil stone or sand paper. (See Figure 59.)

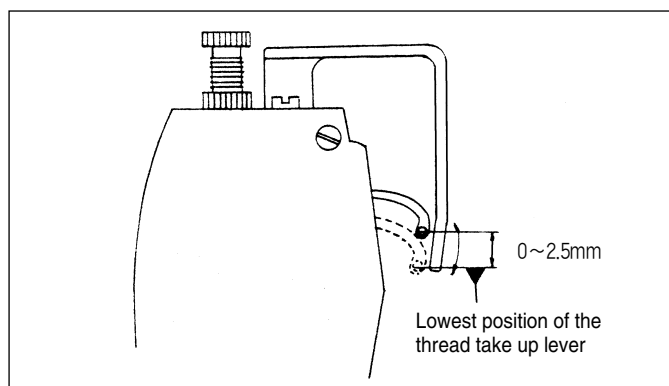

[Figure 58]

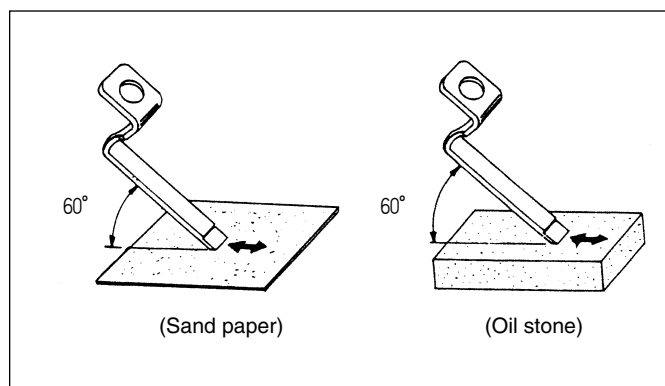

[Figure 59]

18) Replacing movable knife and fixed knife

- (1) Lift the presser foot ① and open the slide plate ②.
 - (2) Disassemble the needle plate ③.
 - (3) Loosen the fixing screw ④, to disassemble the washer ⑤, fixed knife ⑥ and lower thread holder ⑦.
 - (4) Loosen the fixing screw ⑧ and disassemble the movable knife ⑨.
- ※ To assemble, follow the reverse order of disassembling.

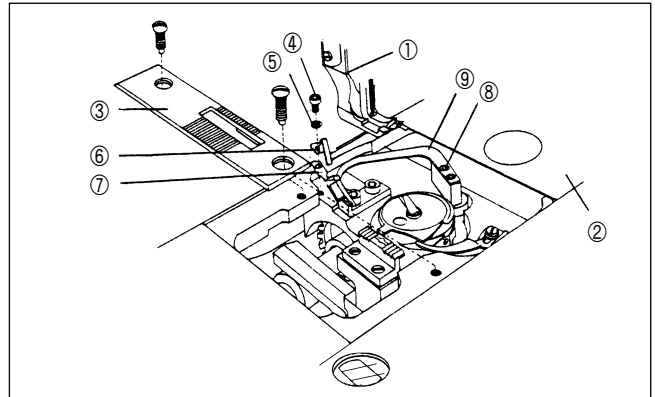

[Figure 60]

19) Adjusting thread release (for automatic trimming type)

If the upper thread is pulled out of the needle hole after trimming, check whether the thread tension adjusting plate ① separates during trimming. To adjust the opening of the thread tension adjusting plate, put the thread release solenoid ② at operation and move back and forth the solenoid shaft collar ③ to make sure that the opening of the plate would be 0.8mm wide. Also, make sure that the plate is completely attached when the solenoid is not working. (See Figure 61)

(Note)

- ※ If the plate does not open widely enough during trimming, but properly assembled, check whether the volume adjusting the remaining upper thread on the control box is too low.

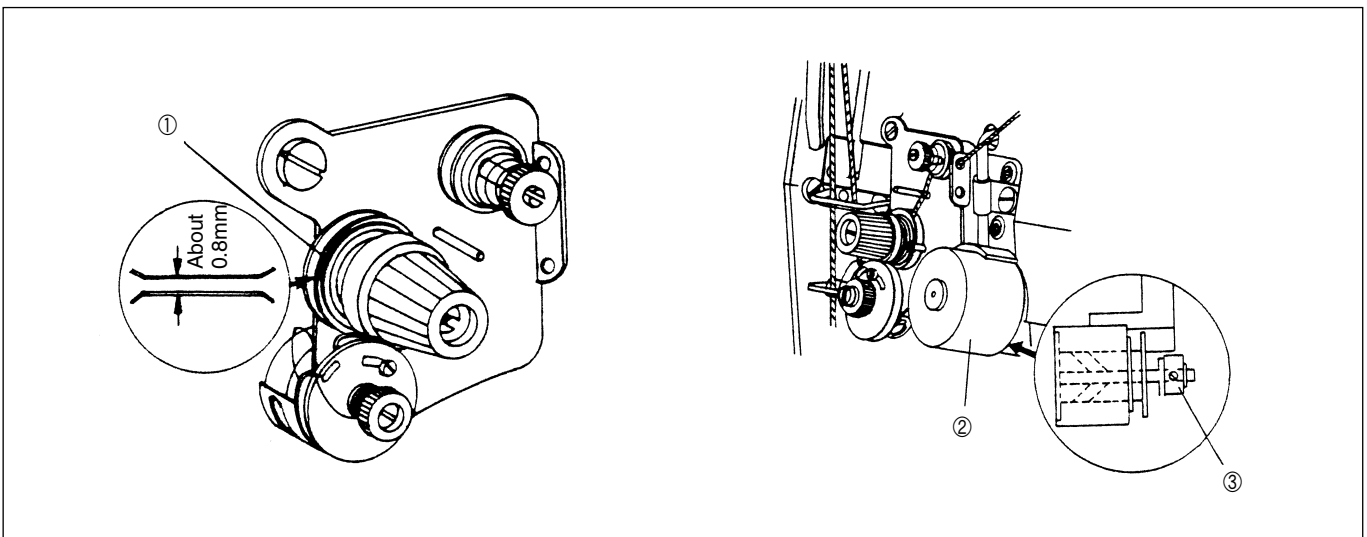

[Figure 61]

Causes of Troubles and Troubleshooting

1) Sewing machine troubleshooting

No	Symptom	Checkpoints	Root cause	Corrective action
1	Needle breaks	Direction and height of needle	Needle is inserted into wrong position.	Reinsert the needle correctly and push in to its highest level.
		Needle	Needle is bent	Change the needle.
		Timing of the feed dog	Bad timing of feed dog	Adjust the timing of feed dog.
		Gap between needle and hook	Bad timing of needle and hook	Adjust the timing of needle and hook.
The heads of the needle and the hook interfere each other.	Adjust the location of the hook.			
2	Thread breaks	Threading method	Wrong threading	Thread the needle correctly.
		Needle	Bent needle	Change the needle.
		Direction and height of needle	The direction and height of the needle inserted is wrong.	Insert the needle correctly.
		Upper thread tension	Too tight upper thread tension	Reduce the tension of upper thread.
		Lower thread tension	Too tight lower thread tension	Reduce the tension of lower thread.
		Working capacity of take-up lever spring	Too much working capacity	Adjust the stroke level.
		Hook	There is a scratch on the hook edge	Remove the scratch on the hook edge.
		Feed dog	There is a scratch on the needle hole of the feed dog	Remove the scratch on the feed dog.
3	Poor thread adjustment	Thread tension	Upper and lower thread tensions are bad.	Adjust the upper and lower thread tension.
		Thread take up spring tension	Thread take up spring tension is inadequate.	Adjust the thread take up spring tension.
		Gap between opener and hook	The gap between the opener and hook is inadequate.	Adjust the gap between the opener and hook.
4	Upper thread falls out when starting to sew or sewing is skipped	Direction and height of needle	Needle is inserted into wrong direction.	Reinsert the needle correctly and push in to its highest level.
		Needle	Needle is bent	Change the needle.
		Threading	Wrong direction	Insert the thread in the right way.
		Hook timing	The timing between the needle and hook is bad.	Adjust the timing between the needle and hook.
		Gap between the needle and the hook	Needle and hook head are too far apart.	Adjust the position of the hook.
		Remaining upper thread length after trimming	The length of the remaining upper thread is too short.	Increase the adjustment volume of the upper thread on the control box.
		Lower thread holder	After trimming, lower thread holder does not hold the lower thread.	Adjust the location and tension of the lower thread holder.
		Check the up-stop position of the needle	Due to problems in the up-stop position of the needle, the thread take up lever pulls the upper thread out of the needle when the sewing starts.	Readjust the needle's up-stop film position.
Check the oil felt tension of upper thread	The upper thread oil felt is pressing the thread too strongly.	Adjust the felt tension.		

No	Symptom	Checkpoints	Root cause	Corrective action
5	Trimming miss	The gap between the movable knife and the hook	The height and distance between the movable knife and the hook do not match.	Readjust the movable knife setting position.
		Check the tension of fixed knife	Tension and contact of movable and fixed knives are bad.	Correct the tension adjustment and surface contact of movable and fixed knives.
		Direction of the needle	Needle is not inserted correctly.	Insert the needle correctly.
		Blade side of movable and fixed knives	Scratch and abrasion of movable and fixed knives.	Replace movable knife or fixed knife.
6	Too short thread length after trimming	Trimming cam timing	Trimming cam timing is bad.	Adjust trimming cam timing.
		Stroke of thread release	Stroke of thread release is too small.	Adjust the thread release stroke.
		Trimming timing	Wrong trimming timing	Adjust the trimming timing.
		Opening of the thread tension adjusting plate	The opening on the thread tension control plate is too small.	Adjust the thread release stroke.
		Tension of auxiliary thread tension adjustment assembly	Too strong tension on the auxiliary thread tension control assembly.	Adjust the tension of the auxiliary thread tension control assembly.
		Working capacity of take-up lever spring	Too much working capacity	Adjust the working capacity.
		Thread release adjustment volume on the control box	Volume is adjusted to too low.	Increase the volume adjustment.

