230, 231, 232, and 233 Series Heavy Duty Mobile Stands



User's Manual



**Instrument
Company**

Helping the World Measure™



Since 1927

www.brunson.us

8000 E. 23rd Street
Kansas City, MO 64129
Toll free: 877-MEASURE
(877.632.7873)
Tel: 816.483.3187
Fax: 816.241.1945

For Sales Assistance:
sales@brunson.us

For Repair or Calibration Assistance:
calibration@brunson.us

Website:
www.brunson.us

Table of Contents

1	General Information
1	Safety Precautions
3	Unpacking and Setup
3	Moving and Positioning Your Stand
4	Stand Operation
5	Maintenance
6	Parts Diagram and List
8	Declaration of Conformity (CE Mark)

*Thank you for purchasing
a Brunson Heavy Duty
Mobile Stand. Remember
that our customer support
does not stop after shipment
of a product—we are here
to help you with any
measurement challenges
that you may have.*



231 Series



233 Series



230 Series



232 Series

230, 231, 232, & 233 Series Heavy Duty Stands

Congratulations and thank you for purchasing a Brunson heavy duty mobile stand. We believe that our stands are the finest available, providing a rock-solid base to meet all of your metrology needs. We have been in the measurement industry since 1927, so we fully understand the importance of a stable, rugged, and durable metrology platform. At Brunson, HELPING THE WORLD MEASURE™ is more than our motto; it truly reflects our passion and dedication to the metrology world.

General Information

Please take a moment to review this manual. It contains important safety and operational information for the stand. Refer to Figure 1 for part names referenced in the instructions. Finally, for future reference, please record the model and serial number for the stand in the space provided below.

Model Number _____

Serial Number _____

Static (non-moving) stability:

Safety Precautions

- a. These stands are designed for use on level surfaces. Operating a stand on non-level surfaces increases the tipping hazard.
- b. Instrumentation / equipment used with the stand should be centered over the axis of the Intermediate Tube. Extending unbalanced loads from the centerline axis increases the tipping hazard.

Dynamic (moving) stability:

- a. Stands should be moved only when no instrumentation / equipment is attached and the intermediate tube is in its fully retracted (lowest) position.
- b. Stands should be moved by manually pushing or pulling no faster than a normal walking pace over smooth, level surfaces. Do not move a stand by pushing or pulling with a powered vehicle.
- c. Avoid sudden starts and stops.

These stands are designed for indoor use only. Wind (or other external) loading was not considered when determining stability.

FIGURE 1

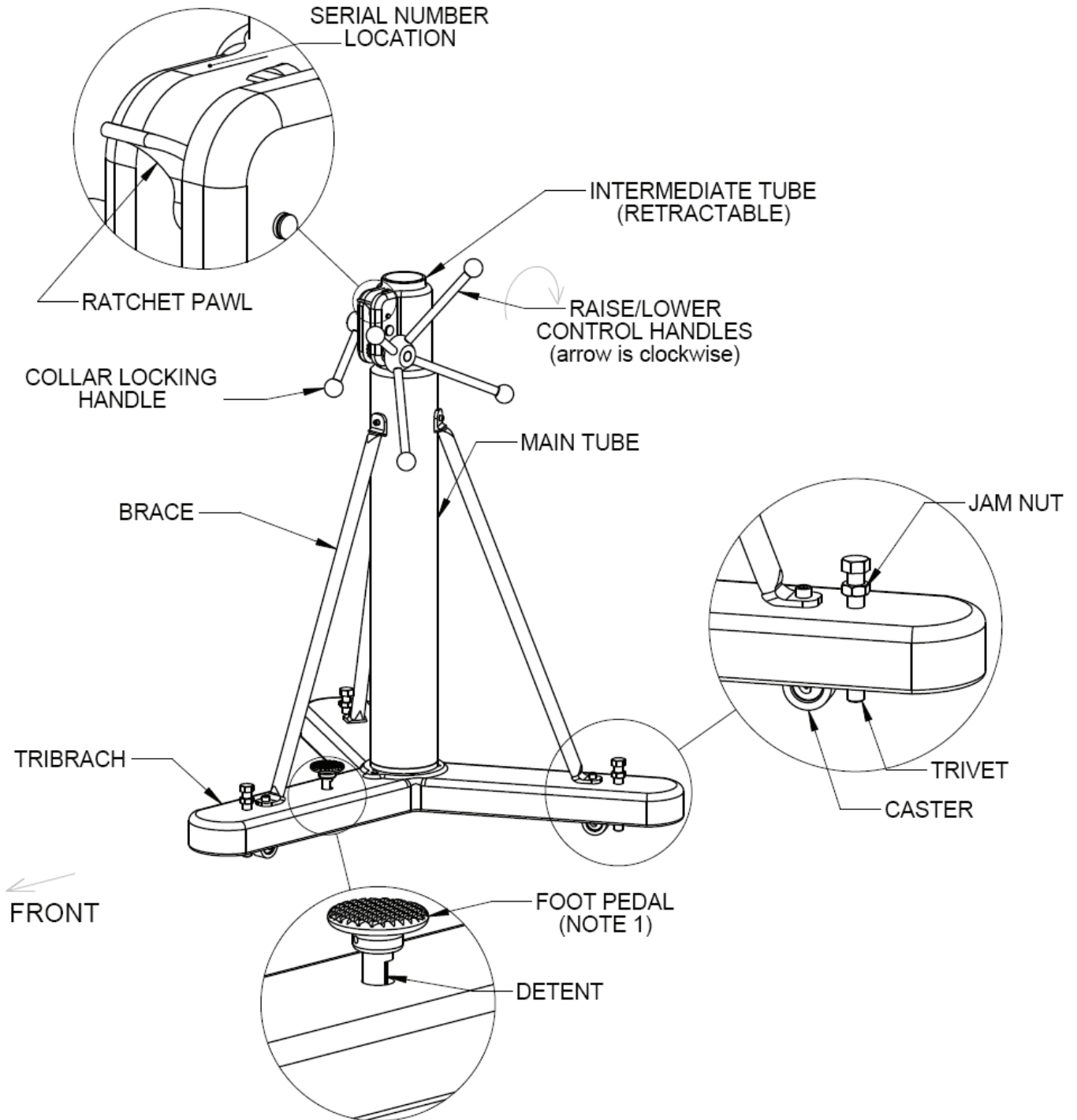

NOTES

1. 232 SERIES MODELS HAVE A HAND WHEEL INSTEAD OF A FOOT PEDAL.

Do not exceed the load capacity of the stand for any attached instrumentation / equipment. The maximum load capacity is listed in Table 1.

Table 1				
Model	Stand weight		Max load capacity	
	lbs	Kg	lbs	Kg
230 Series	314	142	150	68
231 Series	276	125	150	68
232 Series	725	329	150	68
233 Series	294	133	150	68

It is the responsibility of the end user to ensure that any instrumentation / equipment attached to the stand is safely secured.

This is the safety alert symbol. This symbol alerts you to hazards that can hurt you and others, and/or cause damage to equipment. Additional information specific to the hazard will be included with this warning.



WARNING!

Take off the top and sides of the crate by removing the screws. Cut the three band clamps holding the tribrach legs down. With an overhead crane (or suitable alternative), lift the stand off the crate and place on a level surface (refer to Table 1 for stand weights). If a foot pedal is present (Models 230, 231, and 233), ensure it is not engaged—the foot pedal should be “up” and free to move.

Unpacking and Setup

Adjust the trivet bolts so that the casters touch the floor but do not bear any weight from the stand. You should be able to swivel each caster easily by hand. Tighten the jam nut on each trivet bolt.

Ensure that the intermediate tube is in its lowest position and no instrumentation / equipment is attached to the stand.

Moving/Positioning Your Stand

A foot pedal is used to extend the casters on the 230, 231, and 233 Series stands. The 232 Series uses a handwheel. To extend the casters using the foot pedal, use your body weight and step on the pedal while pulling up on the brace directly above the foot pedal. Push inward (toward the main tube) with your foot to latch the detente on the foot pedal. For 232 Series Models, turn the handwheel until the casters extend to the ground.



WARNING!

TIPPING HAZARD

Move the stand over smooth, level surfaces only, with the intermediate tube in its lowest position and no instrumentation / equipment attached. Move the stand by manually pushing or pulling (no faster than a walking pace). Do not tow or push the stand with a powered vehicle.

Manually push or pull the stand into the desired position. The stand should be positioned so that the tribrach leg on which the foot pedal (or handwheel) is mounted points toward the midpoint of the work.

Lower the stand onto the three trivets. If the floor is something other than concrete (e.g. wood, tiled, etc.), you may wish to use pads under the trivets to provide protection for the floor. Lower the stand by stepping down on the foot pedal and moving the detente away from the main tube.

MAINTAIN SUFFICIENT PRESSURE ON THE FOOT PEDAL TO PREVENT THE STAND FROM SUDDENLY DROPPING ONTO THE FLOOR WHEN THE DETENTE CLEARS.



WARNING!

CRUSHING HAZARD

Stands are very heavy! Prior to lowering the stand, ensure area below Tribrach is clear of all obstacles.

Stand Operation

With the intermediate tube fully retracted, attach the instrument / measuring equipment to the stand.

Raise the collar locking handle until the intermediate tube can be raised easily by rotating the control handles.

To raise the intermediate tube, rotate the control handle counter-clockwise (when looking at the hub).

To lower the intermediate tube, release pressure from the ratchet



WARNING!

ROTATING HAZARD

The stands are equipped with an air-check mechanism to prevent rapid descent of the intermediate tube. However, until sufficient air pressure has built up to slow the descent of the intermediate tube, considerable force can be exerted by the free spinning control handle. Therefore, always lower the intermediate tube by applying a resistive force to the control handle.

pawl by slightly raising the intermediate tube, and then retracting and holding the ratchet pawl away from the rack. Rotate the control handle clockwise to lower the intermediate tube.

When the desired height has been reached, lock the intermediate tube in place by rotating the collar locking handle down as tightly as you are able by hand.

Ensure that the trivets fully support the stand by checking to see that each caster rotates freely. If this is not the case, loosen the jam nut and adjust the trivet. After adjusting, ensure that each jam nut is tight against the tribrach.

The stand is positioned and ready to use.

Upon completion of the job, remove the instrument from the stand, raise the collar locking handle, and lower the intermediate tube to the bottom of its travel.

Although the stands were designed for minimal maintenance, two items will help maximize service life:

Maintenance

A small amount of Neats Foot oil injected through the collar opening on a yearly basis will keep the air cushion leather in good condition. This should be done with the intermediate tube in the fully extended position.

A periodic wiping of the intermediate tube with a lightly oiled rag followed by wiping with a dry cloth will preserve the chrome finish.

Parts List and Diagram

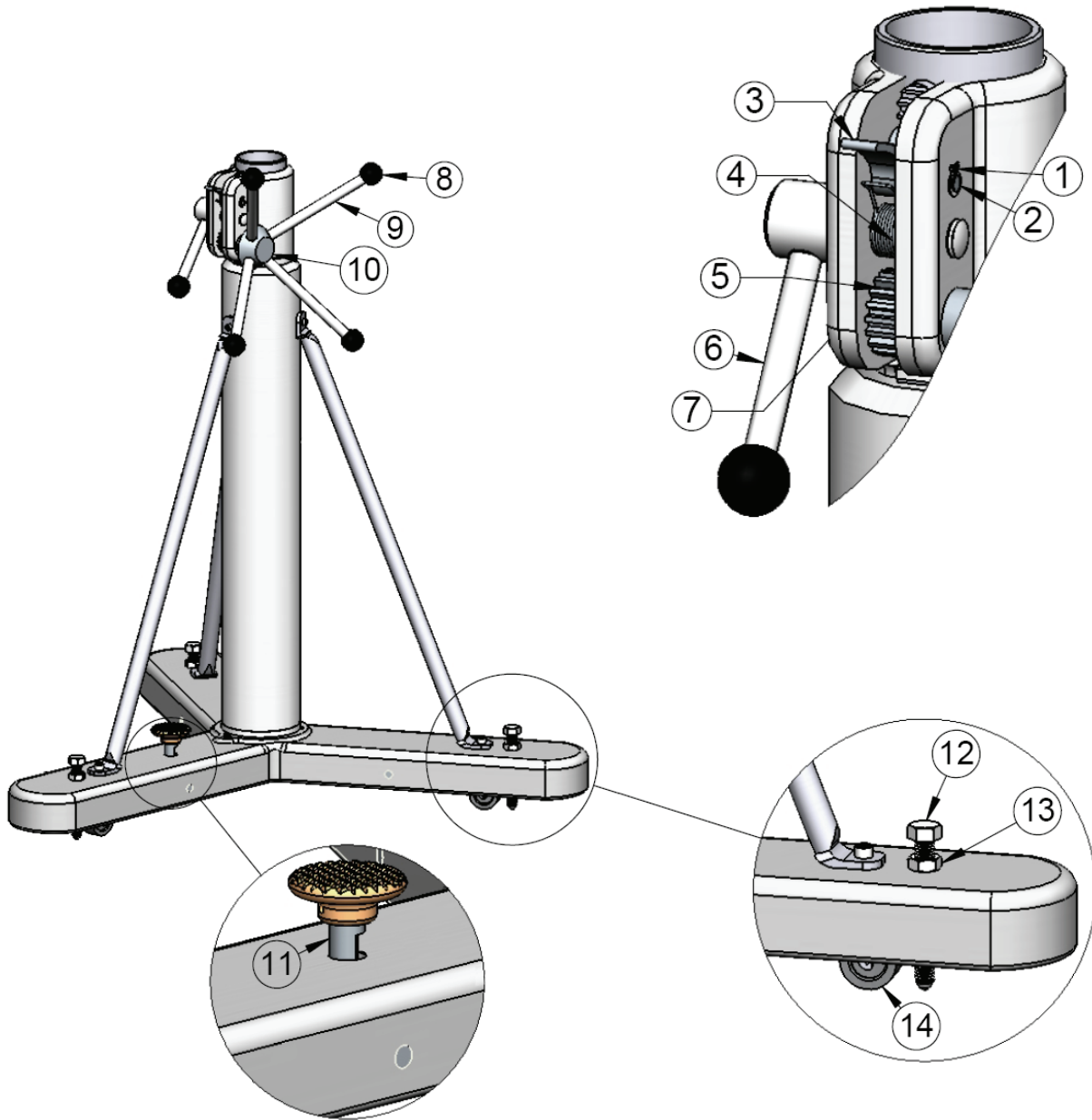

Note: The Model 232 has a handwheel rather than a foot pedal to engage the casters.

Item	Description	Models 230, 231, 233	Model 232
		Part Number	Part Number
1	Retaining Ring	12938	12938
2	Ratchet Shaft	3646	3646
3	Ratchet Pawl	3625	3625
4	Pawl Spring	3655	3655
5	Pinion	3610	3610
6	Clamping Spoke	3608	3608
7	Hub Screw (not shown)	3611	3611
8	Knob	3566	3566
9	Handwheel Spoke	3568	3568
10	Handwheel Hub	1926	3653-G3
11	Lift Plunger	3621	N/A
12	Trivet	3649	3840
13	Hex Jam Nut	Comm. 5/8" - 11	Comm. 1" - 8
14	Caster	3658-1	3690

**EU DECLARATION OF CONFORMITY
WITH
COUNCIL DIRECTIVE 98/37/EC**

<i>Date of Issue:</i>	30 March, 2006
<i>Document Ref:</i>	15190 Rev 1
<i>Directive:</i>	Machinery Directive on machinery safety, 98/37/EC
<i>Conforming Machinery:</i>	HEAVY DUTY MOBILE STANDS MODELS: 231 SERIES 230 SERIES 233 SERIES 232 SERIES
<i>Manufacturer:</i>	Brunson Instrument Company 8000 E. 23rd St. Kansas City MO 64129 USA
<i>Authorised Representative:</i>	Graham Anderson Spectrum Metrology 8 Ireton Avenue Leicester LE49EU UK
<i>Harmonised Standards Referenced or Applied:</i>	BS EN ISO 12100-1:2003, BS EN ISO 12100-2:2003, BS EN 294:1992, BS EN 1050:1997
<i>Specifications with which Conformity is Declared:</i>	Essential Health and Safety Requirements of Annex 1 of the Machinery Directive
We hereby certify that the machinery described above conforms with the essential health and safety requirements of Council Directive 98/37/EC on the approximation of the laws of the Member States relating to the safety of machinery.	
<i>Signed:</i>	<i>Deighton E. Brunson</i>
<i>Signatory:</i>	Deighton E. Brunson, President