

**1000 Series
Gigabit Media Converter &
Industrial Gigabit Ethernet Switch**

**User Manual &
Installation
Guide**

Industrial Gigabit Ethernet Switch Installation Guide

1002MC-SX	1000BaseSX multimode fiber media converter
1002MC-LX-YY	1000BaseLX singlemode fiber media converter
1003GX2-SX	1000BaseSX multimode fiber switch
1003GX2-LX-YY	1000BaseLX singlemode fiber switch
1003GX2-B	Custom mix and match 1003GX2 switch
1005TX	5 port gigabit Ethernet switch

Where "YY" is: 10 for 10km max. fiber segment length
 40 for 40km max. fiber segment length
 70 for 70km max. fiber segment length

1003GX2-B SFP (Mini-GBIC) Fiber Transceivers:

NTSFP-SX	(LC Style Connector, up to 550m)
NTSFP-LX-10	(LC Style Connector, up to 10km)
NTSFP-LX-40	(LC Style Connector, up to 40km)
NTSFP-LX-70	(LC Style Connector, up to 70km)



Copyright, © N-TRON Corp., 2008
820 S. University Blvd., Suite 4E
Mobile, AL USA 36609

All rights reserved. Reproduction, adaptation, or translation without prior written permission from N-TRON Corp. is prohibited, except as allowed under copyright laws.

Ethernet is a registered trademark of Xerox Corporation. All other product names, company names, logos or other designations mentioned herein are trademarks of their respective owners.

The information contained in this document is subject to change without notice. N-TRON Corp. makes no warranty of any kind with regard to this material, including, but not limited to, the implied warranties of merchantability or fitness for a particular purpose. In no event shall N-TRON Corp. be liable for any incidental, special, indirect or consequential damages whatsoever included but not limited to lost profits arising out of errors or omissions in this manual or the information contained herein.

Contact Information :

N-TRON Corp.
820 South University Blvd.
Suite 4E
Mobile, AL 36609
TEL: (251) 342-2164
FAX: (251) 342-6353
Website: www.n-tron.com
Email: N-TRON_Support@n-tron.com

ELECTRICAL SAFETY WARNINGS



This equipment is suitable for use in Class I, Division 2, Groups A, B, C, and D or non-hazardous locations only.

WARNING – Explosion Hazard – Substitution of components may impair suitability for Class I, Division 2.

WARNING – Explosion Hazard – Do not disconnect while circuit is live unless area is known to be non-hazardous.

WARNING – Explosion Hazard – Do not replace the device unless power has been switched off or the area is known to be non-hazardous.

Use 60/75°C rated copper wire, (0.22Nm) 2 lb/in tightening torque for field installed conductors.

WARNING: Do not operate the equipment in the presence of flammable gasses or fumes. Operating electrical equipment in such an environment constitutes a definite safety hazard.

WARNING: If the equipment is used in the manner not specified by N-TRON Corp., the protection provided by the equipment may be impaired.

WARNING: Do not perform any services on the unit unless qualified to do so. Do not substitute unauthorized parts or make unauthorized modifications to the unit.

WARNING: Do not operate the unit with the end plates removed, as this could create a shock or fire hazard.

WARNING: Do not operate the equipment in a manner not specified by this manual.

WARNING: Do not work on equipment or cables during periods of lightning activity.

WARNING: Observe proper DC Voltage polarity when installing power input cables. Reversing voltage polarity can cause permanent damage to the unit and void the warranty.

WARNING: Install only in accordance with Local & National Codes of Authorities Having Jurisdiction.

LASER SAFETY (1002MC and 1003GX2 Models)



CAUTION: CLASS 1 LASER PRODUCT. Do not stare into the laser!)

ENVIRONMENTAL SAFETY WARNINGS



WARNING: Disconnect the power and allow to cool 5 minutes before touching.

1000 Series Industrial Gigabit Ethernet Switches

The 1000 Series Unmanaged Industrial Gigabit Ethernet Switches support high speed layer 2 switching between ports. This series of switches are housed in a ruggedized aluminum enclosure, and provide Category-5 compliant 10/100/1000Base-T connections for high performance network design, and hub/repeater upgrades.

All fiber products utilize the IEEE compliant LC duplex connectors for fiber optic communications in a convenient SFP modular design. All 10/100/1000Base-T ports utilize the RJ45 shielded connectors.

The 1002MC/MCE is a two port unmanaged media converter that converts 10/100/1000Base-T copper to 1000BaseSX/LX full duplex fiber.

The 1003GX2/GXE2 is a three port unmanaged switch that offers one 10/100/1000Base-T copper port and two 1000BaseT/SX/LX full duplex copper/fiber ports.

The 1005TX is a five port unmanaged switch that offers five 10/100/1000Base-T copper ports.

Key Features

- Compact Space Saving Package
- Full IEEE 802.3 Compliance
- Unmanaged Operation
- Extended Environmental Specifications
-40°C to 85°C Operating and Storage Temperature
- Supports Full/Half Duplex Operation
- Up to 10.0 Gb/s Maximum Throughput
- MDIX Auto Sensing Cable
- Auto Sensing Speed and Flow Control
- Full Wire Speed Communication
- Store-and-forward Technology
- Redundant Power Inputs (10-30 VDC)
- LED Link/Activity Status Indication
- Hardened Metal Enclosure
- Industry Standard 35mm DIN Rail Mounted Enclosure

PACKAGE CONTENTS

Please make sure the package contains the following items:

1. 1000 Series Media Converter or Ethernet Switch
2. Product CD

Contact your carrier if any items are damaged.

UNPACKING

Remove all the equipment from the packaging, and store the packaging in a safe place. File any damage claims with the carrier.

CLEANING

Clean only with a damp cloth.

INSTALLATION

Read the following warning before beginning the installation:

WARNING



Never install or work on electrical equipment or cabling during periods of lightning activity. Never connect or disconnect power when hazardous gasses are present.

DIN-Rail Mounting

Install the unit in a standard DIN rail. Recess the unit to allow at least 2" of horizontal clearance for CAT5e cable bend radius or 5" of horizontal clearance for Fiber Optic cable bend radius.

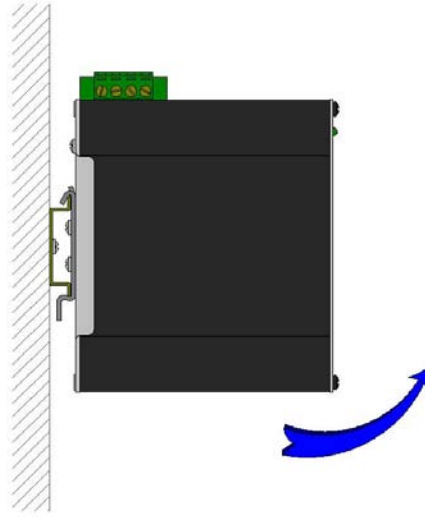
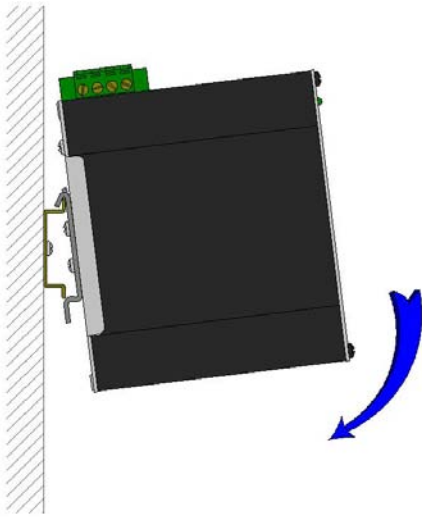

To install the unit to 35mm industrial DIN rail, place the top edge of the included mounting bracket on the back of the unit against the DIN rail at a 15° angle as shown. Rotate the bottom of the unit to the back (away from you) until it snaps into place.

To remove the unit from the 35mm industrial DIN rail, pull forward on the unit until it disengages from the bottom of the DIN rail. Rotate the bottom of the unit towards you and up at an approximate 15° upward angle to completely remove the unit.



URMK

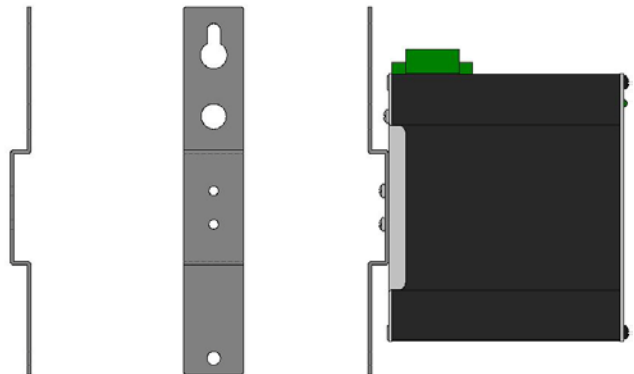

1000-PM

Most N-Tron™ products are designed to be mounted on industry standard 35mm DIN rail. However, DIN rail mounting may not be suitable for all applications. Our Universal Rack Mount Kit (P/N: URMK) may be used to mount the 1000 Series enclosures to standard 19" racks, and our Panel Mount Assembly (P/N: 1000-PM) may be used to mount the 1000 Series enclosures to a panel or any other flat surface.

FRONT PANEL



From Top to Bottom:

-  Green LED lights when Power is connected
- LNK/ACT** Link/Activity LED
- SPD1000** 1000 Speed LED

LEDs: The table below describes the operating modes:

LED	Color	Description
	ON	Power is Applied.
	OFF	Power is OFF.
LNK/ACT	ON	Link established, no Activity on cable.
	BLINKING	Link established, Activity on cable
	OFF	No link activity on cable.
SPD1000	ON	Link is 1000Mbps.
	OFF	Link is 10/100Mbps.

APPLYING POWER (Top View)

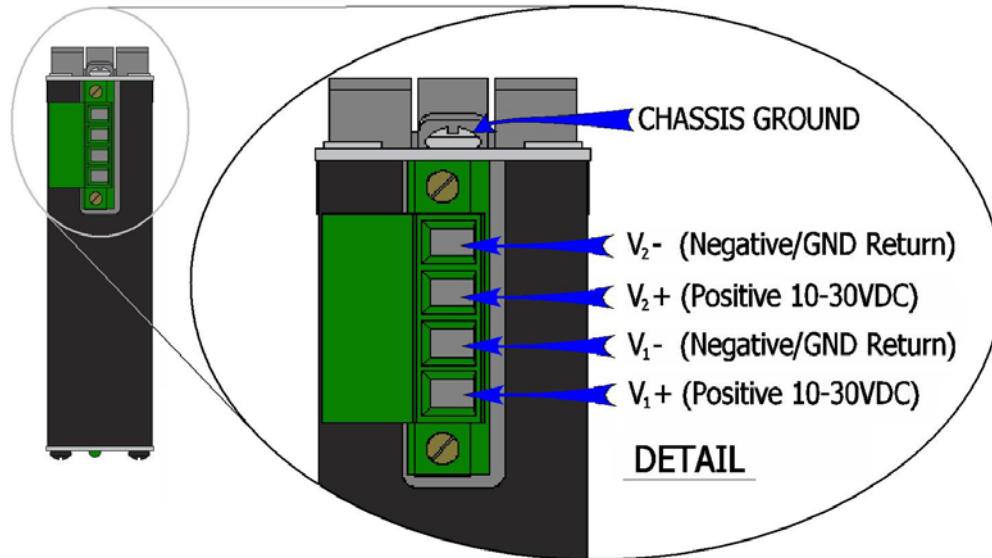

Unscrew & Remove the DC Voltage Input Plug from the top header.
Install the DC Power Cables into the Plug (observing polarity on unit).
Plug the Voltage Input Plug back into the top header.
Tightening torque for the terminal block power plug is **0.5 Nm/0.368 Pound Foot**.
All LEDs will flash ON Momentarily.
Verify the Power LED stays ON (GREEN).

Note: Either V₁ or V₂ can be connected to power for minimal operation. For redundant power operation, V₁ and V₂ plugs must be connected to separate DC Voltage sources. Use wire sizes of 16-28 gauge. The power cord should be limited to less than 10 meters in order to ensure optimum performance.

Recommended 24V DC Power Supplies, similar to:

100-240VAC:

N-Tron NTPS-24-1.3, DC 24V/1.3A (NOTE: Not appropriate for use with M12, POE, and HV models.)

N-TRON SWITCH GROUNDING TECHNIQUES FOR 1000 SERIES

The grounding philosophy of any control system is an integral part of the design. N-Tron switches are designed to be grounded, but the user has been given the flexibility to float the switch when required. The best noise immunity and emissions (i.e. CE) are obtained when the N-Tron switch chassis is connected to earth ground via a drain wire. Some N-Tron switches have metal din-rail brackets that can ground the switch if the din-rail is grounded. In some cases, N-Tron switches with metal brackets can be supplied with optional plastic brackets if isolation is required.

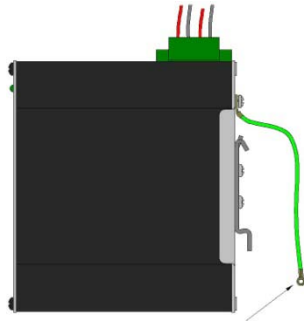

DRAIN WIRE WITH LUG CONNECTING SWITCH CHASSIS TO KNOWN GOOD GROUNDING POINT.

Users may run a drain wire & lug from the screw provided on the back face of the enclosure. In the event the provided grounding screw has been lost, care should be taken to limit the penetration of the outer skin by less than 1/4". Failure to do so may cause irreversible damage to the internal components of the switch.

Note: *Ensure the power supply is grounded properly before applying power to the grounded switch. This may be verified by using a voltmeter to determine that there is no voltage difference between the power supply's negative output terminal and the chassis grounding point of the switch.*

As an alternative grounding method, both V- legs of the power input connector are connected to chassis internally on the PCB. Connecting a drain wire to earth ground from one of the V- terminal plugs as shown here will ground the switch and the chassis. The power leads from the power source should be limited to 3 meters or less in length.

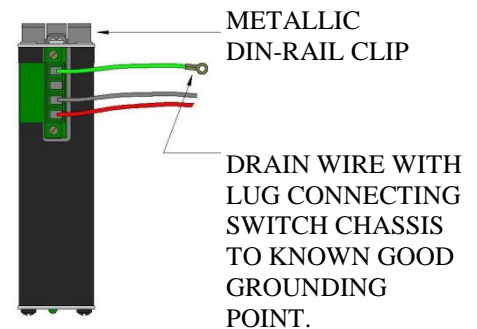

Note: *Before applying power to the grounded switch, you must use a volt meter to verify there is no voltage difference between the power supply's negative output terminal and the switch chassis grounding point.*

If the use of shielded cables is required, it is generally recommended to only connect the shield at one end to prevent ground loops and interfere with low level signals (i.e. thermocouples, RTD, etc.). Cat5e cables manufactured to EIA-568A or 568B specifications are required for use with N-Tron Switches.



In the event all Cat5e patch cable distances are small (i.e. All Ethernet devices are located the same local cabinet and/or referenced to the same earth ground), it is permissible to use fully shielded cables terminated to chassis ground at both ends in systems void of low level analog signals.

CONNECTING THE UNIT

For 10Base-T ports, plug a Category 3 (or greater) twisted pair cable into the RJ45 connector. For 100/1000Base-T ports, plug a Category 5e (or greater) twisted pair cable into the RJ45 connector. Connect the other end to the far end station. Verify that the LNK LEDs are ON once the connection has been completed. To connect any other port to another Switch or Repeater, use a standard Cat5e straight through or crossover cable.

Warning: Creating a port to port connection on the same switch (i.e. loop) is an illegal operation and will create a broadcast storm which will crash the network!

TROUBLESHOOTING

1. Make sure the  (Power LED) is ON.
2. Make sure you are supplying sufficient current for the version chosen. Note: The inrush current will exceed the steady state current by ~ 2X.
3. Verify that Link LEDs are ON for both ports.
4. Verify cabling used between stations.
5. Verify that cabling is Category 3 or greater for 10Mbit Operation.

SUPPORT

Tel: (251)-342-2164

FAX: (251)-342-6353

<http://www.n-tron.com>

N-TRON_Support@n-tron.com

FCC STATEMENT

This product complies with Part 15 of the FCC-A Rules.

Operation is subject to the following conditions:

- (1) This device may not cause harmful Interference
- (2) This device must accept any interference received, including interference that may cause undesired operation.

NOTE: This equipment has been tested and found to comply with the limits for a Class A digital device, pursuant to Part 15 of the FCC Rules. These limits are designed to provide reasonable protection against harmful interference in a residential installation. This equipment generates, uses, and can radiate radio frequency energy and, if not installed and used in accordance with the instructions, may cause harmful interference to radio communications. Operation of this device in a residential area is likely to cause harmful interference in which case the user will be required to correct the interference at his own expense.

INDUSTRY CANADA

This Class A digital apparatus meets all requirements of the Canadian Interference Causing Equipment Regulations. Operation is subject to the following two conditions; (1) this device digital apparatus meets all requirements of the Canadian Interference Causing Equipment Regulations. Operation is subject to the following two conditions; (1) this device may not cause harmful interference, and (2) this device must accept any interference received, including interference that may cause undesired operation.

Cet appareillage numérique de la classe A répond à toutes les exigences de l'interférence canadienne causant des règlements d'équipement. L'opération est sujette aux deux conditions suivantes: (1) ce dispositif peut ne pas causer l'interférence nocive, et (2) ce dispositif doit accepter n'importe quelle interférence reçue, y compris l'interférence qui peut causer l'opération peu désirée.

1002MC - KEY SPECIFICATIONS

Physical

<i>Height:</i>	4.0" (10.16 cm)
<i>Width:</i>	1.0" (2.54 cm)
<i>Depth w/ typical SFP installed:</i>	3.61" (9.165 cm)
<i>Weight:</i>	0.70 lbs (0.32 kg)
<i>DIN Rail:</i>	35 mm

Electrical

<i>Input Voltage:</i>	10-30 VDC (Regulated)
<i>Input Current:</i>	200mA max. @ 24VDC (Steady State)
<i>Inrush Current:</i>	13 Amp/0.8 ms max. @ 24VDC
<i>Input Ripple:</i>	Less than 100 mV
<i>Input Wire Size:</i>	16-28 AWG

Environmental

<i>Operating Temperature:</i>	-40°C to 85°C
<i>Storage Temperature:</i>	-40°C to 85°C
<i>Operating Humidity:</i>	10% to 90% (Non Condensing)
<i>Operating Altitude:</i>	0 to 10,000 ft.

Network Media

<i>10BaseT:</i>	> Cat-3
<i>100BaseT:</i>	> Cat-5
<i>1000BaseT:</i>	> Cat-5e
<i>1000BaseSX Multimode:</i>	50-62.5/125µm
<i>1000BaseLX Singlemode:</i>	7-10/125µm

Connectors

10/100/1000BaseTX:	One (1) RJ45 TX Copper Port
1000Base-X SFP:	One (1) SFP LC Duplex Gigabit Fiber Port

Recommended Minimum Wiring Clearance:

<i>Front:</i>	5" (12.70 cm)
<i>Top:</i>	1" (2.54 cm)

Regulatory Approvals:

Safety: UL Listed per ANSI/ISA-12.12.01-2000 (US and Canada) and listed for use in Class I, Div 2, Groups A, B, C, D, T4.

EMI: EN61000-6-4, EN55011 - Class A
FCC Title 47, Part 15, Subpart B - Class A
ICES-003 – Class A

EMS: EN61000-6-2
EN61000-4-2 (ESD)
EN61000-4-3 (RS)
EN61000-4-4 (EFT)
EN61000-4-5 (Surge)
EN61000-4-6 (Conducted Disturbances)

Warranty: 3 year from the date of purchase.



1003GX2 - KEY SPECIFICATIONS

Physical

<i>Height:</i>	4.0" (10.16 cm)
<i>Width:</i>	1.0" (2.54 cm)
<i>Depth w/ typical SFP installed:</i>	3.61" (9.165 cm)
<i>Weight:</i>	0.7 lbs (0.32 kg)
<i>DIN Rail:</i>	35 mm

Electrical

<i>Input Voltage:</i>	10-30 VDC (Regulated)
<i>Input Current:</i>	200mA max. @ 24VDC (Steady State)
<i>Inrush Current:</i>	13 Amp/0.8 ms max. @ 24VDC
<i>Input Ripple:</i>	Less than 100 mV
<i>Input Wire Size:</i>	16-28 AWG

Environmental

<i>Operating Temperature:</i>	-40°C to 85°C
<i>Storage Temperature:</i>	-40°C to 85°C
<i>Operating Humidity:</i>	10% to 90% (Non Condensing)
<i>Operating Altitude:</i>	0 to 10,000 ft.

Network Media

<i>10BaseT:</i>	> Cat-3
<i>100BaseT:</i>	> Cat-5
<i>1000BaseT:</i>	> Cat-5e
<i>1000BaseSX Multimode:</i>	50-62.5/125µm
<i>1000BaseLX Singlemode:</i>	7-10/125µm

Connectors

10/100/1000BaseTX:	One (1) RJ45 TX Copper Port
1000Base-X SFP:	Up to two (2) SFP LC Duplex Gigabit Fiber Ports

Recommended Minimum Wiring Clearance:

<i>Front:</i>	5" (12.70 cm)
<i>Top:</i>	1" (2.54 cm)

Regulatory Approvals:

Safety: UL Listed per ANSI/ISA-12.12.01-2000 (US and Canada) and listed for use in Class I, Div 2, Groups A, B, C, D, T4.

EMI: EN61000-6-4, EN55011 - Class A
FCC Title 47, Part 15, Subpart B - Class A
ICES-003 – Class A

EMS: EN61000-6-2
EN61000-4-2 (ESD)
EN61000-4-3 (RS)
EN61000-4-4 (EFT)
EN61000-4-5 (Surge)
EN61000-4-6 (Conducted Disturbances)

Warranty: 3 year from the date of purchase.



1005TX - KEY SPECIFICATIONS

Physical

<i>Height:</i>	4.0" (10.16 cm)
<i>Width:</i>	1.0" (2.54 cm)
<i>Depth:</i>	3.61" (9.165 cm)
<i>Weight:</i>	0.70 lbs (0.32 kg)
<i>DIN Rail:</i>	35 mm

Electrical

<i>Input Voltage:</i>	10-30 VDC (Regulated)
<i>Input Current:</i>	230mA max. @ 24VDC (Steady State)
<i>Inrush Current:</i>	13 Amp/0.61 ms max. @ 24VDC
<i>Input Ripple:</i>	Less than 100 mV
<i>Input Wire Size:</i>	16-28 AWG

Environmental

<i>Operating Temperature:</i>	-40°C to 85°C
<i>Storage Temperature:</i>	-40°C to 85°C
<i>Operating Humidity:</i>	10% to 90% (Non Condensing)
<i>Operating Altitude:</i>	0 to 10,000 ft.

Network Media

<i>10BaseT:</i>	> Cat-3
<i>100BaseT:</i>	> Cat-5
<i>1000BaseT:</i>	> Cat-5e

Connectors

10/100/1000BaseTX:	Five (5) RJ45 TX Copper Ports
--------------------	-------------------------------

Recommended Minimum Wiring Clearance:

<i>Front:</i>	2" (5.08 cm)
<i>Top:</i>	1" (2.54 cm)

Regulatory Approvals:

Safety: UL Listed per ANSI/ISA-12.12.01-2000 (US and Canada) and listed for use in Class I, Div 2, Groups A, B, C, D, T4.

EMI: EN61000-6-4, EN55011 - Class A
FCC Title 47, Part 15, Subpart B - Class A
ICES-003 – Class A

EMS: EN61000-6-2
EN61000-4-2 (ESD)
EN61000-4-3 (RS)
EN61000-4-4 (EFT)
EN61000-4-5 (Surge)
EN61000-4-6 (Conducted Disturbances)

Warranty: 3 year from the date of purchase.



N-TRON Limited Warranty

N-TRON, Corp. warrants to the end user that this hardware product will be free from defects in workmanship and materials, under normal use and service, for the applicable warranty period from the date of purchase from N-TRON or its authorized reseller. If a product does not operate as warranted during the applicable warranty period, N-TRON shall, at its option and expense, repair the defective product or part, deliver to customer an equivalent product or part to replace the defective item, or refund to customer the purchase price paid for the defective product. All products that are replaced will become the property of N-TRON. Replacement products may be new or reconditioned. Any replaced or repaired product or part has a ninety (90) day warranty or the remainder of the initial warranty period, whichever is longer. N-TRON shall not be responsible for any custom software or firmware, configuration information, or memory data of customer contained in, stored on, or integrated with any products returned to N-TRON pursuant to any warranty.

OBTAINING WARRANTY SERVICE: Customer must contact N-TRON within the applicable warranty period to obtain warranty service authorization. Dated proof of purchase from N-TRON or its authorized reseller may be required. Products returned to N-TRON must be pre-authorized by N-TRON with a Return Material Authorization (RMA) number marked on the outside of the package, and sent prepaid and packaged appropriately for safe shipment. Responsibility for loss or damage does not transfer to N-TRON until the returned item is received by N-TRON. The repaired or replaced item will be shipped to the customer, at N-TRON's expense, not later than thirty (30) days after N-TRON receives the product. N-TRON shall not be responsible for any software, firmware, information, or memory data of customer contained in, stored on, or integrated with any products returned to N-TRON for repair, whether under warranty or not.

ADVANCE REPLACEMENT OPTION: Upon registration, this product qualifies for advance replacement. A replacement product will be shipped within three (3) days after verification by N-TRON that the product is considered defective. The shipment of advance replacement products is subject to local legal requirements and may not be available in all locations. When an advance replacement is provided and customer fails to return the original product to N-TRON within fifteen (15) days after shipment of the replacement, N-TRON will charge customer for the replacement product, at list price.

WARRANTIES EXCLUSIVE: IF AN N-TRON PRODUCT DOES NOT OPERATE AS WARRANTED ABOVE, CUSTOMER'S SOLE REMEDY FOR BREACH OF THAT WARRANTY SHALL BE REPAIR, REPLACEMENT, OR REFUND OF THE PURCHASE PRICE PAID, AT N-TRON'S OPTION. TO THE FULL EXTENT ALLOWED BY LAW, THE FOREGOING WARRANTIES AND REMEDIES ARE EXCLUSIVE AND ARE IN LIEU OF ALL OTHER WARRANTIES, TERMS, OR CONDITIONS, EXPRESS OR IMPLIED, EITHER IN FACT OR BY OPERATION OF LAW, STATUTORY OR OTHERWISE, INCLUDING WARRANTIES, TERMS, OR CONDITIONS OF MERCHANTABILITY, FITNESS FOR A PARTICULAR PURPOSE, SATISFACTORY QUALITY, CORRESPONDENCE WITH DESCRIPTION, AND NON-INFRINGEMENT, ALL OF WHICH ARE EXPRESSLY DISCLAIMED. N-TRON NEITHER ASSUMES NOR AUTHORIZES ANY OTHER PERSON TO ASSUME FOR IT ANY OTHER LIABILITY IN CONNECTION WITH THE SALE, INSTALLATION, MAINTENANCE OR USE OF ITS PRODUCTS. N-TRON SHALL NOT BE LIABLE UNDER THIS WARRANTY IF ITS TESTING AND EXAMINATION DISCLOSE THAT THE ALLEGED DEFECT OR MALFUNCTION IN THE PRODUCT DOES NOT EXIST OR WAS CAUSED BY CUSTOMER'S OR ANY THIRD PERSON'S MISUSE, NEGLIGENCE, IMPROPER INSTALLATION OR TESTING, UNAUTHORIZED ATTEMPTS TO OPEN, REPAIR OR MODIFY THE PRODUCT, OR ANY OTHER CAUSE BEYOND THE RANGE OF THE INTENDED USE, OR BY ACCIDENT, FIRE, LIGHTNING, POWER CUTS OR OUTAGES, OTHER HAZARDS, OR ACTS OF GOD.

LIMITATION OF LIABILITY: TO THE FULL EXTENT ALLOWED BY LAW, N-TRON ALSO EXCLUDES FOR ITSELF AND ITS SUPPLIERS ANY LIABILITY, WHETHER BASED IN CONTRACT OR TORT (INCLUDING NEGLIGENCE), FOR INCIDENTAL, CONSEQUENTIAL, INDIRECT, SPECIAL, OR PUNITIVE DAMAGES OF ANY KIND, OR FOR LOSS OF REVENUE OR PROFITS, LOSS OF BUSINESS, LOSS OF INFORMATION OR DATA, OR OTHER FINANCIAL LOSS ARISING OUT OF OR IN CONNECTION WITH THE SALE, INSTALLATION, MAINTENANCE, USE, PERFORMANCE, FAILURE, OR INTERRUPTION OF ITS PRODUCTS, EVEN IF N-TRON OR ITS AUTHORIZED RESELLER HAS BEEN ADVISED OF THE POSSIBILITY OF SUCH DAMAGES, AND LIMITS ITS LIABILITY TO REPAIR, REPLACEMENT, OR REFUND OF THE PURCHASE PRICE PAID, AT N-TRON'S OPTION. THIS DISCLAIMER OF LIABILITY FOR DAMAGES WILL NOT BE AFFECTED IF ANY REMEDY PROVIDED HEREIN SHALL FAIL OF ITS ESSENTIAL PURPOSE.

DISCLAIMER: Some countries, states, or provinces do not allow the exclusion or limitation of implied warranties or the limitation of incidental or consequential damages for certain products supplied to consumers or the limitation of liability for personal injury, so the above limitations and exclusions may be limited in their application to you. When the implied warranties are not allowed to be excluded in their entirety, they will be limited to the duration of the applicable written warranty. This warranty gives you specific legal rights which may vary depending on local law.

GOVERNING LAW: This Limited Warranty shall be governed by the laws of the State of Alabama, U.S.A.