

**Service and**  
**Maintenance**  
**User Manual**

**BOSS**  
**BA435 PISTON**  
**Hydraulic Air Compressor**



This manual must be read carefully before using your Boss Industries Air Compressor. Store in a safe and convenient location for future reference.

For technical support:

Phone: (800) 635-6587 (USA)

Phone: (219) 324-7776 (Outside USA)

Fax: (877) 254-4249 (USA)

service@bossair.com (email)

<http://www.bossair.com> (website)



# Contents

<b>Revision List</b> .....	5
<b>Welcome</b> .....	6
<b>Safety Information</b> .....	7
Warnings, safety rules, and hazards.....	7
<b>Specifications</b> .....	10
<b>Description of Components</b> .....	11
<b>Installation &amp; Operation</b> .....	12
Installation.....	12
Before Starting.....	14
Initial Start-up & Test.....	16
<b>Maintenance</b> .....	17
Overview.....	17
Recommended Spare Parts List.....	17
Maintenance Schedule.....	18
Lubrication Recommendation.....	19
Compressor Oil .....	20
Air Intake Filter.....	20
Hydraulic Oil Cooler.....	21
<b>Troubleshooting</b> .....	22
General Tips.....	22
Contacting Boss Ind.....	23
Where To Find Specific Machine Information.....	23

<b>Warranty</b> .....	25
Warranty Statement.....	26
Summary of Main Warranty Points.....	27
Return Goods Instructions.....	28
Preparation of Part Return.....	28
Filing Procedures.....	28
Other Info.....	29
Transit Damage.....	29
<b>Drawings</b> .....	31
Frame System.....	32
Piston System.....	34
Piston Assembly.....	36
Cooler System.....	38
Hydraulic Drive System.....	40
Discharge System.....	42
Canopy System.....	44
Decal System.....	46
Wiring Diagram.....	48

# Revision List

<b>DATE</b>	<b>LOCATION</b>	<b>DESCRIPTION OF CHANGE</b>	<b>INITIALS</b>

# Welcome

## General Information

Thank you for choosing the Boss BA435 Hydraulic Air Compressor. Before operating this compressor, read over this manual and become well acquainted with your new machine. Doing this will increase your safety and maximize the life of the machine.

While this manual is written to be as accurate as possible, Boss strives to continually improve the efficiency and performance of its machines. As a result, sometimes there may be slight differences between a given version of the manual and the machine.

## Boss BA435 Hydraulic Air Compressor

The Boss BA435 is a compact, strategically designed system. It integrates all major components on a single frame, which is enclosed in a tough, weather-resistant canopy.

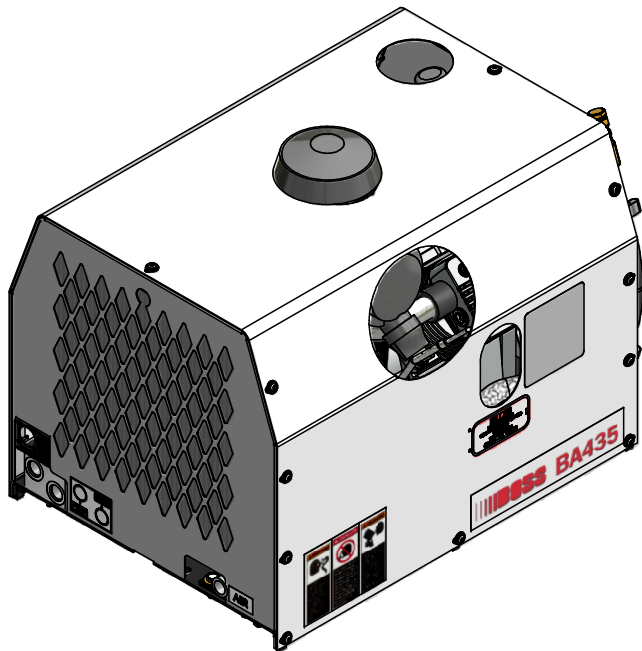
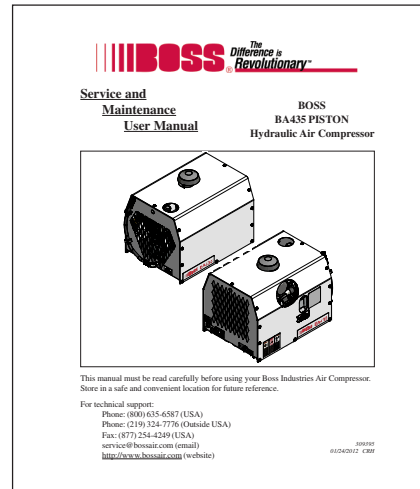

The BA435 Piston design provides output of up to 35 CFM (cubic feet of air per minute) at up to a maximum of 150 PSI (pounds per square inch). High output at relatively low GPM (gallons per minute) translates into the most efficient, quiet, and reliable system in its class, designed to handle virtually any application.

The BA435 Piston also has enhanced safety features offering applications designed to protect your most valuable resource - your operating crew. To prevent overheating, a high temperature switch will shut down the machine in the event of high discharge temperatures.

# Safety

## IMPORTANT READ BEFORE OPERATING EQUIPMENT

Remember, safety is basically common sense. While there are standard safety rules, each situation has its own peculiarities that cannot always be covered by rules. Therefore with your experience and common sense, you are in a position to ensure your and others safety. Lack of attention to safety can result in: accidents, personal injury, reduction in efficiency and worst of all – Loss of Life. Watch for safety hazards and correct them promptly.

Understanding the proper operation of this equipment is critical to its safe operation. The owner, lessor or operator of this equipment is hereby notified and forewarned that any failure to observe the safety and operating guidelines may result in injury and/or damage. Boss expressly disclaims responsibility or liability for any injury or damage caused by failure to observe these specified precautions or by failure to exercise the ordinary caution and due care required while operating or handling this equipment, even though not expressly specified.

In addition to following these safety guidelines, the operator should follow any company specific guidelines and procedures. Consult your immediate supervisor for specific company safety guidelines and/or procedures.

The following safety symbols are used throughout the manual to draw attention to important information. If the information is not carefully read and the instructions are not followed, severe injury, death, and/or damage to property and equipment may occur.



Indicate[s] an imminently hazardous situation, which, if not avoided, **will** result in death or serious injury.



Indicate[s] a potentially hazardous situation, which, if not avoided, **could** result in death or serious injury.



Indicate[s] a potentially hazardous situation, which, if not avoided, **could** result in minor or moderate injury.



Indicate[s] a potentially unsafe situation or practice, which, if not avoided can result in property and/or equipment damage only.

# Safety

The following safety precautions are a general guide to safe operation of the equipment.



**WARNING**

Read and understand the operations manual and all other safety instructions before using this equipment. Failure to follow operating instructions and/or failure to follow maintenance procedures and intervals could result in personal injury, death, and/or damage to equipment and property.



**DANGER**

Pressurized System. Do not attempt to remove any compressor parts without first completely relieving entire system of pressure. Do not attempt to service any part of the equipment while in operation. Never attempt to repair or modify any pressure vessel or device.



**DANGER**

System contains hot oil. The compressor system must be shut off prior to servicing. Open the service valve to ensure complete relief of system air pressure and stored energy. Then permit system to cool down prior to adding compressor oil or servicing the unit.



**DANGER**

Do not use air from this compressor for breathing or food processing. Air from this compressor will cause severe injury if used for breathing or food processing.



**DANGER**

The compressor is designed to compress air only. Do not attempt to compress other gases. Compression of other gases may create a situation where an explosion or fire may occur.



**DANGER**

Do not use flammable solvents for cleaning compressor parts as this can cause the unit to ignite or explode during operation. Keep combustibles out of and away from compressor inlet, and any associated enclosures.



# Safety

## DANGER

Never disable, override, or remove safeties, either temporarily or permanently.

## DANGER

Do not modify pressure switches to operate equipment at a higher pressure than specified. When using a hose reel, the complete system must be designed with safety valves in accordance with OSHA Regulation 1910.169.

## DANGER

Never leave the machine running unattended or leave a tool connected to an air hose when not using. Relieve system of all stored air pressure after use.

## WARNING

Never adjust the pressure switch to a setting of greater than 150 PSI. Operating the compressor at greater than 150 PSI may result in personal injury and property damage.

## CAUTION

Mount the compressor in a stable location capable of supporting 180 lbs. Slight vibration may occur during operation and the machine may move if not securely mounted.

## CAUTION

When using tools, maintain secure footing at all times. Do not overreach or awkwardly use air tools.

## NOTICE

Prior to moving vehicle to the next work site, drain the air tank. To prevent the collection of water in the tank drain daily.

## NOTICE

Use only Boss approved replacement parts.

# Specifications

<b>POWER SOURCE</b>	HYDRAULIC MOTOR	<b>OPERATING SPEED</b>	1400 RPM MAX.
<b>CYLINDER CONFIG.</b>	V4 Piston	<b>OIL CAPACITY</b>	1 1/3 QTS
<b>DIMENSIONS</b>	26 1/2"L x 19 1/8"H x 19 3/4"W	<b>WEIGHT</b>	180 LBS.
<b>DELIVERY @ 100 PSI</b>	35 CFM	<b>HYDRAULIC RESERVOIR REQ. *</b>	12 GALLON MINIMUM
<b>COOLING</b>	AIR	<b>NORMAL GPM @ 1400 RPM</b>	9.3 GPM
<b>FAN DIAMETER</b>	14 1/8"	<b>NORMAL OPERATING PSI</b>	1850 PSI
<b>MAXIMUM PSI</b>	2400 PSI		

\* Hydraulic reservoir requirement for compressor only. Additional capacity will be needed to other hydraulic equipment.

*SPECIFICATIONS SUBJECT TO CHANGE WITHOUT PRIOR NOTICE*

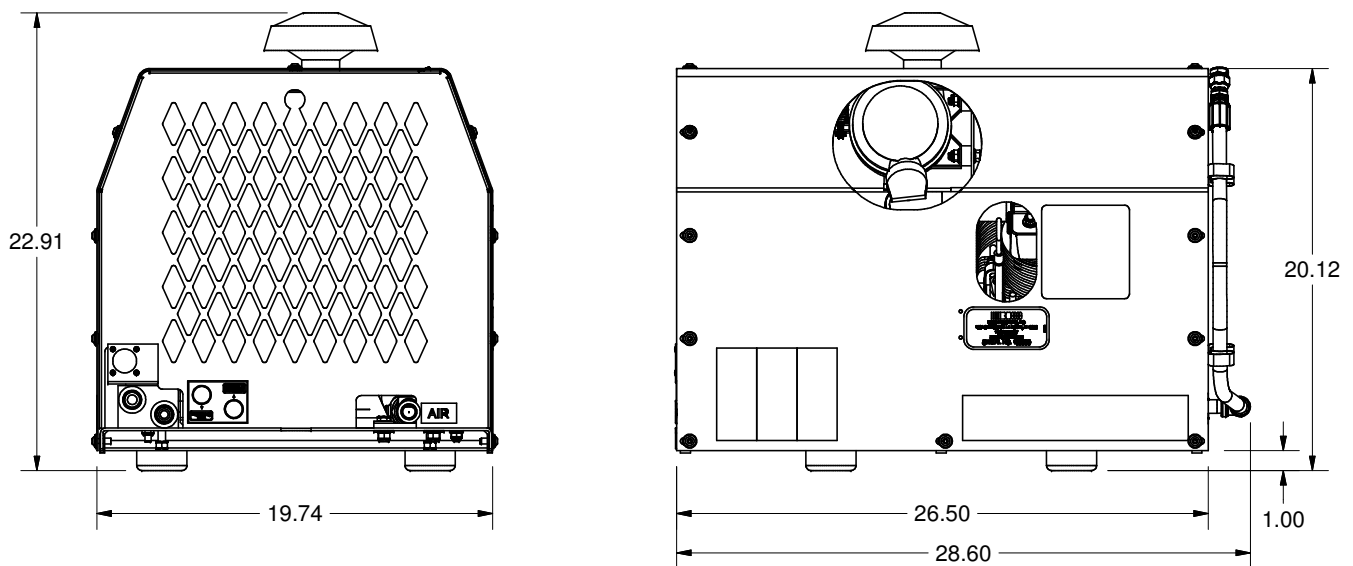

- BA435 system is to run intermittently.
- When the BA435 is installed with other hydraulic drive equipment it will require a dedicated flow line.
- If other hydraulics are required, the reservoir size should be at least 12 GAL for the BA435 plus all the other manufacturer's requirements.
- Mounting surface must be capable of 180 lbs. load spread over the four mounting holes.
- Cooling air intake must not see air temperatures above ambient.
- Cooling air discharge must have 10" clearance from any obstructions.
- Ambient running conditions: -20° to 100° F.
- 20° maximum operating slope.

# Description of Components

**Compressor Assembly** - The Boss BA435 hydraulic drive piston compressor assembly is a positive displacement, intermittent-flow, reciprocating unit. The piston compressor consists of a crankshaft, oil filter, oil pump, four connecting rods, pistons, cylinders, and valve assemblies. As the crankshaft rotates, the pistons move up and down. As they move down, a vacuum is created above the piston which allows the reed valve to open and fill the area above the piston with air. When the pistons move back up, this air is discharged from the compressor. Oil lubricates the bearings and cylinder walls as the crankshaft rotates, ensuring that the system stays cool.

**Hydraulic Oil Cooling Systems** - The compressor cooling system consists of a hydraulic cooler mounted on the compressor frame. Cool air is drawn through the vented end panel and flows over the compressor surface and through the hydraulic cooler, exiting out the front vented panel. Allow for adequate clearance (10") for the air to exit. Also, the package location should not be subjected to air temperatures above ambient.

**Dipstick** - The dipstick indicates the fluid level in the crank case. Proper level should be at the "FULL" line on the dipstick. Check this level when the compressor is disengaged and the vehicle is parked on level ground. Fluid level should be checked prior to each use.

**Electrical System** - The Boss compressor's standard electrical system consists of:

- Hydraulic oil cooler fan assembly and relay.
- 12VDC N.O. hydraulic solenoid.
- Switch relay for customer equipment interface during compressor operation.

*Most air tools operating pressure range is between 90 and 125 psi. Operating above the tools' recommended pressures will decrease the life of the tool. Higher operating pressure can also over torque nuts and bolts fatiguing the fastener and mating parts. Strictly adhere to tool operating pressures and torque standards set forth by the tool manufacturer and the specifications of the equipment that work is being performed on.*



**Pressure Switch** - The pressure switch is a N.C. electrical switch set to open at 150 PSI and set to close at 115 PSI. The pressure switch controls the N.O. hydraulic solenoid. If service air pressure is under 150 PSI, the pressure switch will remain in its normally closed state, keeping the N.O. hydraulic solenoid closed and the compressor producing air. If the service valve is closed or the tool using the air is off, service line pressure will rise to 150 PSI. This will cause the pressure switch to open and deactivate the hydraulic solenoid. The compressor will stop making air. If the tool is turned on or the service valve is opened, the service line pressure will drop. When the pressure falls to 115 PSI, the pressure switch will close, energizing the N.O. hydraulic solenoid forcing flow to the motor and the compressor will start producing air to meet the demand.



Never adjust the pressure switch to a setting of greater than 150 PSI. Operating the compressor at greater than 150 PSI may result in personal injury and property damage.

# Installation & Operation

This air compressor should be installed only by those who have been trained and delegated to do so and who have read and understand the manual. Failure to follow the instructions, procedures, and safety precautions in this manual may result in accidents and injuries.

Install, use, and operate this air compressor only in full compliance with all pertinent O.S.H.A., Federal, State, and Local codes or requirements in addition to Boss and any company's regulations.

Do not modify this compressor except with written factory approval.

## **NOTICE**

**ALL TRUCKS SHOULD BE ROAD TESTED PRIOR TO STARTING INSTALLATION TO ISOLATE ANY PREVIOUS TRUCK PROBLEMS.**

### 1. Mounting the Compressor

When mounting the compressor care should be taken to ensure that its location does not impede the operation of other components on the vehicle. For example, if your vehicle is equipped with a crane, you must make sure the compressor will not interfere with the swing of the crane. In addition, the compressor should be installed in an area that permits cool ambient air to enter the air filter and the hot air to exhaust without recirculating into the air filter. 10" of exhaust clearance is needed. The compressor air filter is mounted on the frame. Cool ambient air is drawn in from under the frame. One last consideration in the mounting should be the routing of hoses and electrical wires. The frame mounting holes are shown below and the unit should be secured to the vehicle with 3/8 inch grade 8 bolts and washers. Hardware supplied with unit, may not work in all applications. The compressor weighs 180 lbs. Ensure that you have a sub structure to support at least that weight. Be sure to follow all National Vehicle Safety Standards.

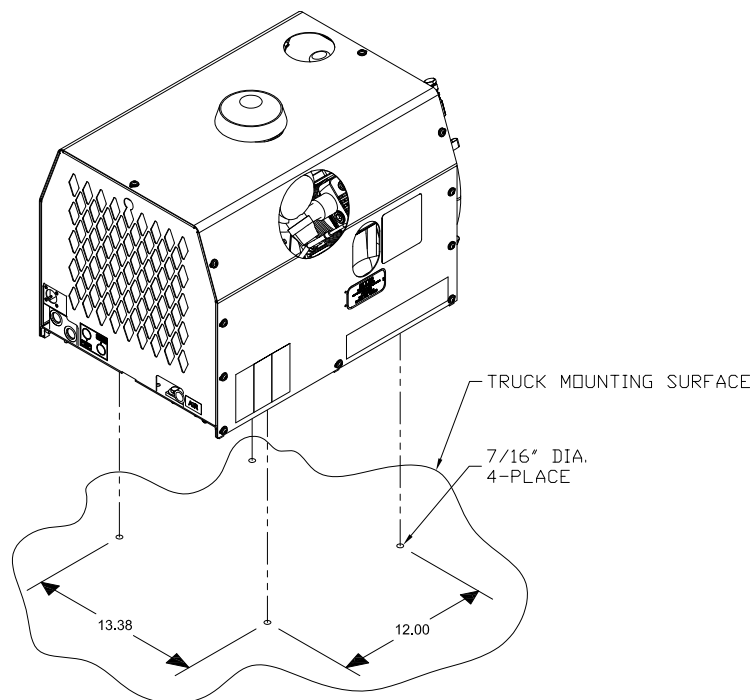

# Installation & Operation

## 2. Installing the Wiring

This unit is shipped from the factory with all necessary internal wiring installed. The only remaining wiring necessary is the wiring needed to interface your vehicle/power source with the Boss compressor. The unit is shipped with a 5 pin connector, they need to be connected as follows:

1. Pin “B” and Pin “E” are to be connected directly to battery positive (Pin “B” red wire) and battery negative (Pin “E” black wire).
2. Compressor Only: for normal compressor operation, supply 12VDC inputs to Pin “A” (yellow wire). This will activate the system and pressure the tank to 150 PSI. The system will then unload until the tank has dropped to 110 PSI, at which point it will automatically activate. The 12VDC output signal from Pin “D” (orange wire) will be present only when the system is compressing.
3. Pin “C” (green wire) is connected to PTO ground.

## 3. Connecting the Hydraulic Hoses

The hydraulic hoses to the compressor should be connected directly to the hydraulic block. The port sizes in the block are -10 SAE. The pressure “P” input line should be made from a good quality high pressure hydraulic hose 1/2” or 3/4” I.D. rated to handle the hydraulic systems on the vehicle. The return line to tank “T” can be made from a medium pressure (min. 1000 PSI) hydraulic hose 3/4” I.D. Care should be taken to see that the hoses are not installed with kinks or bends that inhibit flow of the hydraulic oil. Lack of flow could result in damage to the motor and compressor. Lastly check to make sure hoses are not in contact with sharp objects or edges that may fray, chafe or cut them over time. Secure all hoses with tie down straps or clamps.

## 4. Connecting the Air Hose

The air discharge hose should be connected directly to the “AIR” port. The fitting is a 1/2” female NPT. The air line should be made from a good quality (min. 200 PSI) hydraulic hose 1/2” or 3/4” I.D. Care should be taken to see that the hose is not installed with kinks. When adding an air hose, ensure OSHA Regulation 1910.169 is followed.

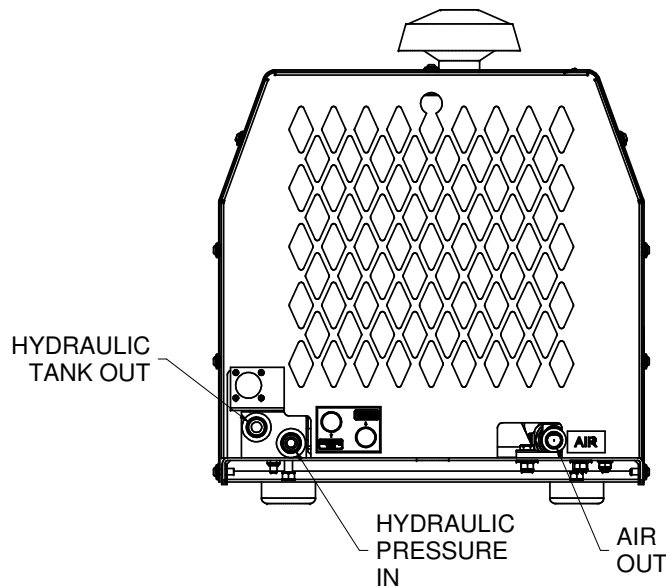

# Installation & Operation

## **WARNING**

A compressor service valve should be located at the hose reel inlet or the customer's air connection port when a hose reel is not used. Typical plumbing from the machine's air outlet port occurs in the following order:

1. Air tank
2. OSHA valve.
3. Service valve.
4. Moisture trap/gauge/oiler combination (when used).
5. Hose reel (when used).

## **5. Pre-Start-up Inspection Checks**

This inspection should be done prior the compressor test.

- I. Check all assemblies, clamps, fittings, hose connections, nuts, and bolts to ensure they are properly tied and secured to the vehicle. This is a very critical area of inspection. The vehicle should not be moved until this inspection has been completed.
- II. Remove all tools, rags, and installation equipment from the area.
- III. Check compressor oil level and hydraulic fluid level. Check all valves to ensure they are in correct operating position.
- IV. Apply decals to proper location. Make sure that the area is cleaned prior to applying decals. All decals should have a professional appearance upon application.
- V. Vacuum all areas that have metal or plastic shavings. Wipe all fingerprints off unit and vehicle.

# Installation & Operation

V. Record all serial numbers for this installation.

A. Vehicle V.I.N.

---

B. Hydraulic Pump Data

---

C. Compressor Serial Number

---

D. Boss Serial Number

---

E. Air Tank Serial Number

---

F. Note any special applications relating to specific installations.

---

VI. Check all fluid levels (position the unit on a level surface so that proper amount of fluids can be added).

A. Fuel to provide three hours of operation.

B. Hydraulic fluid levels may have to be topped off after test.

C. Compressor.

Check the compressor oil level (see lubricant section of the operator and parts section for type of lubricant to use). 1. Add oil if needed. 2. Additional oil may need to be added after test. 3. Top off oil level to the "FULL" line on the dipstick when finished with the test.

D. Any other applicable fluids.

E. Transmission fluid and PTO box.

# Installation & Operation

## **6. Operating Procedure**

- I. Read the operation section in the manual carefully before proceeding onto the initial start-up.
- II. Start power source and allow for warm-up.
- III. Verify the compressor is disengaged.
- IV. Engage hydraulic system per company policy.
- V. Engage compressor.

## **7. Shutdown Procedure**

- I. Disengage compressor circuit.
- II. Relieve system of stored air.

### **Operating Conditions**

The following conditions should exist for maximum performance of the compressor. The truck should be as close to level as possible when operating. Operation in ambient temperatures above 100°F (38°C) may experience high temperature shutdown.



# Maintenance

This section contains instructions for performing the inspection, lubrication, and maintenance procedures required to maintain the compressor in proper operating condition. The importance of performing the maintenance described herein cannot be over emphasized.

The periodic maintenance procedures to be performed on the equipment covered by this manual are listed on the following page. It should be understood that the intervals between inspections specified are maximum interval. More frequent inspections should be made if the unit is operating in a dusty environment, in high ambient temperature, or in other unusual conditions. A planned program of periodic inspection and maintenance will help avoid premature failure and costly repairs. Daily visual inspections should become a routine.



**Compressor must be shut down and completely relieved of pressure prior to checking fluid levels. Open service valve to ensure relief of system air pressure. Relieve all stored air pressure energy prior to starting machine. Failure to comply with this warning will cause damage to property and serious bodily harm.**

## Recommended Spare Parts List

PART NUMBER	DESCRIPTION
80279	KIT, REPAIR REED VALVE
308157	ELEMENT, AIR FILTER
301267	SPIDER, CURVED JAW
302936	KIT, REPAIR HYD MOTOR SEAL
308245	LUBRICANT, 2QT BOX SYNTH

## How To Order Parts

For Parts and/or Service Support:

Phone: (800) 635-6587 (USA)  
Phone: (219) 324-7776 (Outside USA)  
Local Fax: (877) 254-4249  
service@bossair.com (email)  
<http://www.bossair.com> (website)

# Maintenance

The LUBRICATION AND MAINTENANCE CHART lists serviceable items on this compressor package. The items are listed according to their frequency of maintenance, followed by those items which need only “As Required” maintenance.

## Lubrication and Maintenance Chart

SERVICE INTERVAL	MAINTENANCE OPERATION
DAILY	<ol style="list-style-type: none"><li>1. Check crankcase oil level. Add if needed.</li><li>2. Drain condensation from air receiver.</li></ol>
WEEKLY	<ol style="list-style-type: none"><li>1. Inspect the air intake.</li><li>2. Check the cylinder head stud torque (see NOTE 2).</li><li>3. Check the operation of the receiver safety valves.</li></ol>
EVERY 3 MONTHS	<ol style="list-style-type: none"><li>1. Change the crankcase oil (see NOTE 1).</li><li>2. Check cooler fins for dirt and obstruction. Clean if needed.</li></ol>
EVERY 6 MONTHS	<ol style="list-style-type: none"><li>1. Inspect the drive coupling for wear.</li><li>2. Change the air cleaner.</li></ol>

Use only Boss’ synthetic compressor oil. The use of any other oil causes excessive carbon buildup, and may void the warranty on the compressor.

### NOTE 1.

Under normal operating conditions, oil changes are required every 3 months. When operating in a dirty environment, change the oil and air filter more frequently as your particular operating conditions dictate. Compressor oil capacity is 1-1/3 quarts.

### NOTE 2.

Cylinder head stud torque **MUST** be checked after the initial day of operation. The compressor must be cold (room temperature) before re-torquing of studs. Torque studs to 240 in-lbs plus or minus 10 in-lbs.

# Maintenance

## Lubrication Recommendations

### CAUTION

It is important that the compressor oil be of a recommended type and that this oil as well as the air filter element be inspected and replaced as started in this manual.

The following are general characteristics for a piston lubricant. Due to the impossibility of establishing limits on all physical and chemical properties of lubricants which can affect their performance in the compressor over a broad range of environmental influences, the responsibility for recommending and consistently furnishing a suitable heavy duty lubricant must rest with the individual supplier if they choose not to use the recommended Boss Piston lubricant. The lubricant supplier's recommendation must, therefore, be based upon not only the following general characteristics, but also upon his own knowledge of the suitability of the recommended lubricant in piston air compressors operating in the particular environment involved.

	UNIT	METHOD	RATING
ISO VISCOSITY GRADE		ISO 3448	46
KINEMATIC VISCOSITY		ASTM D445	
- AT 40°C (104°F)	mm <sup>2</sup> /s		46
- AT 100°C (212°F)	mm <sup>2</sup> /s		7.7
DENSITY AT 15°C (59°F)	g/mL	ASTM D1298	.843
FLASH POINT (COC)	°C (°F)	ASTM D92	235 (455)
POUR POINT	°C (°F)	ASTM D97	<-45 (-49)
VISCOSITY INDEX (VI)		DIN ISO 2909	135
RUST PREVENTION PROPERTIES		ASTM D665-B	PASS
WATER SEPERABILITY	min	ASTM D1401	10
ROTATING PRESSURE VESSEL OXIDATION TEST	min	ASTM D2272	2200
FZG LOAD CARRYING TEST	FAILURE LOAD STAGE	CEC-L-07-A-95	>12

### NOTICE

Mixing different types or brands of lubricants is not recommended due to the possibility of a dilution of the additives or a reaction between additives or different types.

# Maintenance

## **NOTICE**

Due to environmental factors, the useful life of all “extended life” lubricants may be shorter than quoted by the lubricant supplier. Boss encourages the user to closely monitor the lubricant condition and to participate in an oil analysis program with the supplier.

## **NOTICE**

No lubricant, however good and/or expensive, can replace proper maintenance and attention. Select and use it wisely.

### **Compressor Oil Fill, Level, and Drain**

Before adding or changing compressor oil, make sure that the compressor is completely relieved of pressure. Oil is added at the fill cap on a pipe on the rear of the crankcase. A drain line is located on the rear panel of the machine. The proper oil level is to the “FULL” line on the dipstick, when the unit is shut down and has had time to settle. The truck must be level when checking the oil. **DO NOT OVERFILL.** The oil capacity is given in “Compressor Specifications”.

## **⚠ DANGER**

**Do not attempt to drain condensate, remove the oil level fill cap, or break any connection in the air or oil system without shutting off the compressor and relieve the system of all stored air pressure.**

### **Air Intake Filter (P/N 300854)**

The air intake filter is a heavy-duty dry type high efficiency filter designed to protect the compressor from dust and foreign objects.

Frequency of maintenance of the filter depends on dust conditions at the operating site. The filter element must be serviced when clogged. A clogged air filter element will reduce compressor performance and cause premature wear of components.

# Maintenance

## **HYDRAULIC OIL COOLER**

The interior of the oil cooler should be cleaned when the pressure drop across it at full flow exceeds 25 PSI.

1. Remove cooler.
2. Circulate a suitable solvent to dissolve and remove varnish and sludge.
3. Flush generously with hydraulic oil.
4. Once the cooler is reinstalled, fill the hydraulic system with the proper fluid to their appropriate levels.

# Troubleshooting

The troubleshooting procedures to be performed on the equipment are listed below. Each symptom of trouble for a component or system is followed by a list of probable causes of the trouble and suggested procedures to be followed to identify the cause.

In general, the procedures listed should be performed in the order in which they are listed, although the order may be varied if the need is indicated by conditions under which the trouble occurred. In any event, the procedures which can be performed in the least amount of time and with the least amount of removal or disassembly of parts, should be performed first.

## **LOW OIL PRESSURE**

1. Low oil level.
2. Loose pipe plug on oil pump cover.
3. Worn or defective oil pump.
4. Crack or scratch on oil pump cover.

## **NO OIL PRESSURE**

1. Defective oil pump
2. Blocked oil passage.
3. Damage oil pump drive pin.

## **COMPRESSOR WILL NOT ENGAGE**

1. No power supplied to compressor.
2. Internal circuit breaker tripped.
3. Hydraulic system not engaged.
4. Defective pressure switch.

## **COMPRESSOR ENGAGES BUT WILL NOT PRESSURIZE TANK**

1. Air leak in plumbing.
2. Worn piston rings or valve plates.

## **COMPRESSOR DOES NOT RECOVER PRESSURE AS FAST AS IT SHOULD**

1. Dirty filter.
2. Air leak in plumbing.
3. Worn valve plates or piston rings.

# Troubleshooting

## Contacting Boss Industries, Inc.

Local Phone: (800) 635-6587

Local Fax: (877) 254-4249

<http://www.bossair.com>

When calling for technical support, have the following information available:

Machine Serial Number

Description of the problem

## How To Find Specific Machine Information

The machine serial number can be found on the Boss serial tag located on the side of machine.

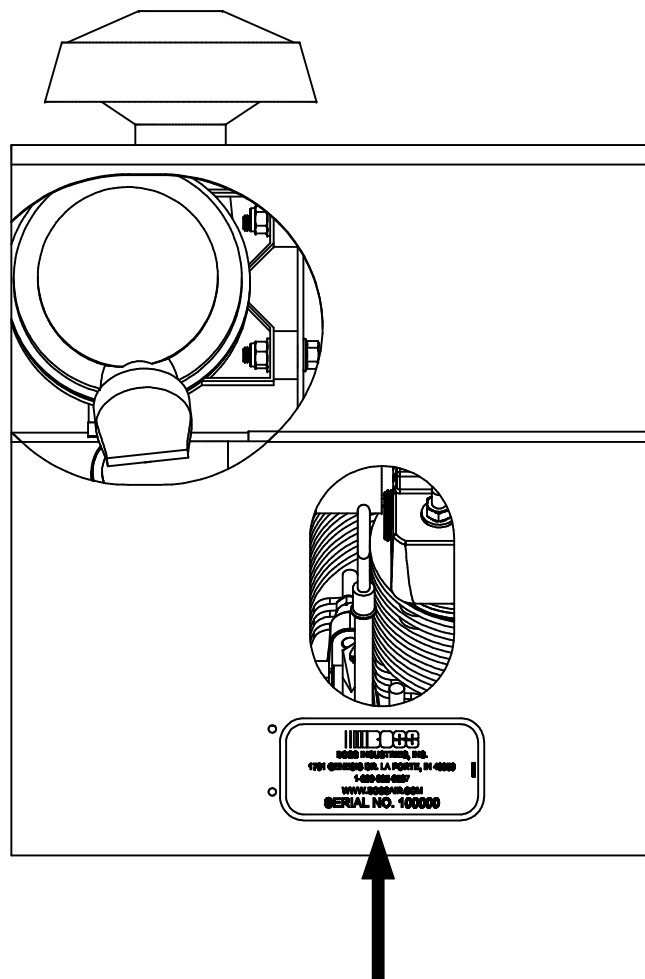





## **WARRANTY SECTION**

# Warranty

Boss Industries, Inc. warrants that this Piston Compressor unit conforms to applicable drawings and specifications approved in writing by Boss Industries, Inc.. The unit assembly will be free from defects in material and workmanship for a period of one (1) years from the date of initial operation or eighteen (18) months from the date of shipment, whichever period first expires. All other components and parts of Boss Industries, Inc. manufacture, will be free from defects in material and workmanship for a period of one (1) year from the date of initial operation or eighteen (18) months from the date of shipment, whichever period first expires. If within such period Boss Industries, Inc. receives from the Buyer written notice of and alleged defect in or nonconformance of the unit, all other components and parts of Boss Industries, Inc. manufacture and if in the judgment of Boss Industries, Inc. these items do not conform or are found to be defective in material of workmanship, Boss Industries, Inc. will at its option either, (a) furnish a Service Representative to correct defective workmanship, or (b) upon return of the item F.O.B. Boss Industries, Inc. original shipping point, repair or replace the item or issue credit for the replacement item ordered by Buyer, (Defective material must be returned within thirty (30) days of return shipping instructions from Boss Industries, Inc.. Failure to do so within specified time will result in forfeiture of claim), or (c) refund the full purchase price for the item without interest. Factory installed units will also include warranty on installation for a period of one (1) year. This warranty does not cover damage caused by accident, misuse or negligence. If the compressor unit is disassembled the warranty is void. Boss Industries, Inc. sole responsibility and Buyer's exclusive remedy hereunder is limited to such repair, replacement, or repayment of the purchase price. Parts not of Boss Industries, Inc. manufacture are warranted only to the extent that they are warranted by the original manufacture. Boss Industries, Inc. shall have no responsibility for any cost or expense incurred by Buyer from inability of Boss Industries, Inc. to repair under said warranty when such inability is beyond the control of Boss Industries, Inc. or caused solely by Buyer.

**There are no other warranties, express, statutory or implied, including those of merchantability and of fitness of purpose; nor any affirmation of fact or representation which extends beyond the description of the face hereof.**

This warranty shall be void and Boss Industries, Inc. shall have no responsibility to repair, replace, or repay the purchase price of defective or damaged parts or components resulting directly or indirectly from the use of repair or replacement parts not of Boss Industries, Inc. manufacture or approved by Boss Industries, Inc. or from Buyer's failure to store, install, maintain, and operate the compressor according to the recommendations contained in the Operating and Parts Manual and good engineering practice. The total responsibility of Boss Industries, Inc. for claims, losses, liabilities or damages, whether in contract or tort, arising out of or related to its products shall not exceed the purchase price. In no event shall Boss Industries, Inc. be liable for any special, indirect, incidental or consequential damages of any charter, including, but not limited to, loss of use of productive facilities or equipment, loss of profits, property damage, expenses incurred in reliance on the performance of Boss Industries, Inc., or lost production, whether suffered by Buyer or any third party.

**Boss Industries, Inc.  
1761 Genesis Drive  
LaPorte, IN 46350**

# Warranty

## Summary of Main Warranty Provisions

As claims, policies and procedure are governed by the terms of the Boss Industries, Inc. warranty, it is necessary to outline some of the more important provisions.

The Boss Industries, Inc. warranty applies only to new and unused products which, after shipment from the factory, have not been altered, changed, repaired or mistreated in any manner whatsoever. Normal maintenance items such as lubricants and filters are not warrantable items.

Parts not of Boss Industries, Inc. manufacture are warranted only to the extent they are warranted by the original manufacturer.

Damage resulting from abuse, neglect, misapplication or overloading of a machine, accessory or part is not covered under warranty.

Deterioration or wear occasioned by chemical and/or abrasive action or excessive heat shall not constitute defects.

Parts replacement and/or correction of defective workmanship will normally be handled by Boss Industries, Inc. or their authorized distributor.

Failure to file a detailed warranty claim/service report for each occurrence of material defect of defective workmanship will cause warranty claim to be rejected.

Defective material must be returned within 30 days of receipt of shipping instructions. Failure to do so within specified time will result in forfeiture of claim.

The distributor is responsible for the initial investigation and write up of the warranty claim.

Distributor shall be allowed no more than 30 days from date of repair to file a warranty claim/service report.

Warranty for failure of Boss Industries, Inc. replacement parts covers the net cost of the part only, not labor and mileage.

The Boss Industries, Inc. warranty does not cover diagnostic calls and travel. That is time spent traveling to the machine to analyze the problem and returning with the proper tools and parts to correct the problem.

Boss Industries, Inc. will deduct from allowable credits for excess freight caused by sender failing to follow return shipping instructions.

Distributors or end-users automatically deducting the value of a warranty claim from outstanding balances due and payable to Boss Industries, Inc. prior to receiving written notification of Boss Industries, Inc. approval of the warranty claim may be subject to forfeiture of the entire claim.

# Warranty

## **Warranty/Return Goods Instructions**

The warranty/return procedure outlined below is provided to give the claimant the information necessary to file a warranty/return claim, and enable Boss Industries, Inc. the ability to best serve its' customers.

Please see the following instructions to initiate a return:

Contact Boss Industries, Inc. Returns Department by telephone at 800-635-6587 . You may also send a fax at 877-254-4249.

## **Warranty Claims - Preparation of Part Return**

Parts returned to the factory must be properly packaged to prevent damage during shipment. Damage to a part as a result of improper handling or packing could be cause for denial. When addressing the package for shipment, the following information must be on the outside of, or tagged clearly, to the package.

1. Return Goods Authorization #.
2. Distributor or end-users return address.
3. Correct factory address.
4. Number of packages pertaining to each claim.

NOTE: Our warranty requires that all defective parts be returned to Boss Industries, Inc. freight prepaid. Items sent without RGA number will not be accepted. Unauthorized Returns Will Immediately Be Refused At Dock.

## **Return or Warranty Claims - Filing Procedures**

1. Initiate through a purchase order for warranty part or request for credit.
2. RGA will accompany replacement part.
3. Boss Industries, Inc. will confirm disposition of failed part within 30 days of receipt and or request additional information.
4. Claim denial will result in issuance of a letter of denial.
5. Boss Industries, Inc. will consider each claim on its' own merit and reserves the right to accept or reject claim request.
6. Send Warranty Claim to:  
Boss Industries, Inc.  
1761 Genesis Drive  
LaPorte, IN 46350

# Warranty

## General

An approved claim depends on the following provision:

1. An RGA # must be issued by Boss Industries, Inc.. (See filing procedures.)
2. Failed part must be returned within 30 days of original invoice date, freight prepaid, with RGA #.
3. Part is determined to be defective.
4. Workmanship is determined to be defective.
5. Machine is within warranty period.
6. Machine has been operated within design conditions.

Claims made through distributors must be verified by distributor prior to contacting Boss Industries, Inc..

## Damage in Transit

Do not return damaged merchandise to Boss Industries, Inc., please follow claim procedure.

1. Loss in transit:  
The merchandise in our kit or provided in our factory installations has been thoroughly inspected or carefully installed and tested before leaving our plant. However, regardless of the care taken at the factory, there is a possibility that damage may occur in shipment. For this reason, it is recommended that the unit be carefully inspected for evidence of possible damage or malfunction during the first few hours of operation. Responsibility for the safe delivery of the kit or factory installed unit was assumed by the carrier at the time of shipment. Therefore, claims for loss or damage to the contents of the kit or factory installed unit should be made upon the carrier.
2. Concealed loss or damage:  
Concealed loss or damage means loss or damage, which does not become apparent until the kit is unpacked or the factory-installed unit is run by the end-user. The contents of the kit or factory installed unit may be damaged due to rough handling while in route to its destination, even though the kit or factory installed unit shows no external damage. When the damage is discovered upon unpacking, make a written request for inspection by the carrier agent within fifteen days of delivery date. Then file a claim with the carrier since such damage is the carrier's responsibility.

By following these instructions carefully, we guarantee our full support of your claims, to protect you against loss from concealed damage.

3. Visible Loss or Damage  
Any external evidence of loss or damage must be noted on the Freight Bill or Express Receipt, and signed by the carrier's agent. Failure to adequately describe such external evidence of loss, or damage may result in the carrier refusing to honor a damage claim. The carrier will supply the form required to file such a claim.



**PARTS AND  
ILLUSTRATION  
SECTION**

# Frame System

Parts List			
ITEM	QTY	PART NUMBER	DESCRIPTION
1	1	301405	BASE
2	2	929806-150	BOLT
3	6	925506-198	NUT
4	1	301248	BRACKET
5	1	301665	MOTOR
6	6	938206-071	WASHER
7	1	301593	DECAL
8	1	301266	HUB
9	1	301265	HUB
10	1	301267	SPIDER
11	1	301628	WASHER
12	1	929405-100	BOLT
13	6	961504-090	NUT
14	1	970412-106	ELBOW
15	1	970408-088	ELBOW
16	4	929806-100	BOLT



# Frame System

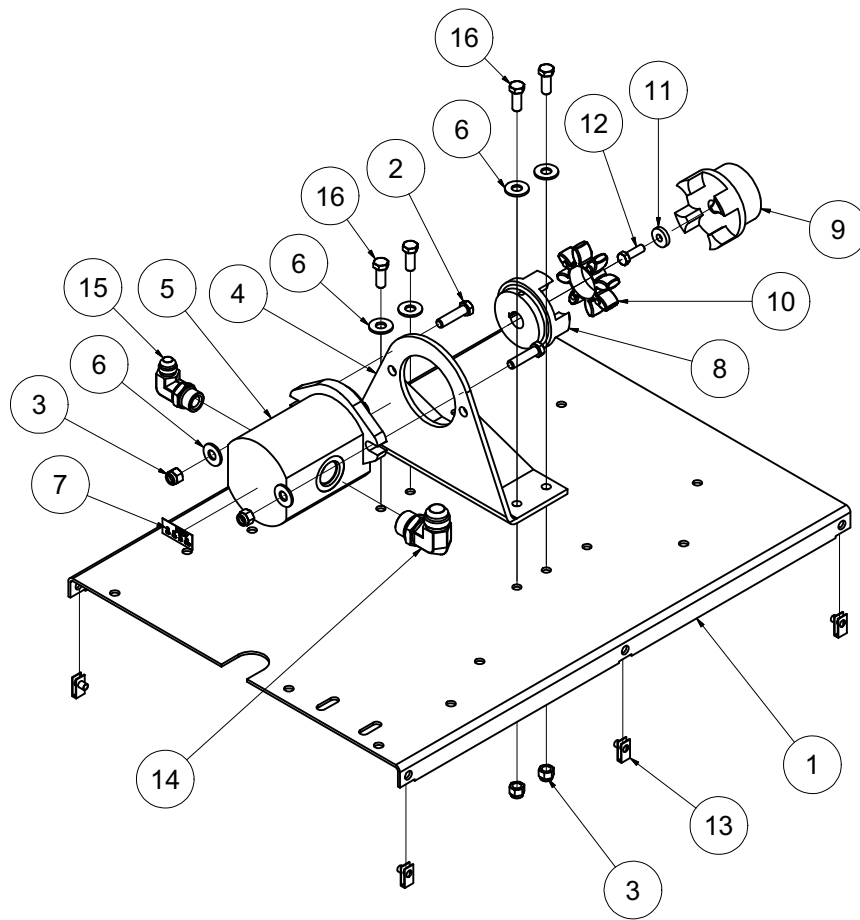

# Oil Cooler System

Parts List			
ITEM	QTY	PART NUMBER	DESCRIPTION
1	1	300909-025	BREAKER
2	1	301432	SUPPORT
3	1	301433	BRACKET
4	1	301434	SHROUD
5	1	80061-12	BLOCK
6	6	924305-166	NUT
7	6	938605-071	WASHER
8	8	961505-140	NUT
9	12	929705-075	BOLT
10	1	300836	COOLER
11	2	960212-075	ELBOW
12	2	300211	RELAY
13	1	970512-088	CONNECTOR
14	1	970508-088	CONNECTOR
15	1	305244	BRACKET
16	1	301577	FAN ASSY
17	4	993204-062	RIVET
18	4	943102-038	RIVET
19	2	929105-300	BOLT
20	4	993603-025	RIVET

# Oil Cooler System

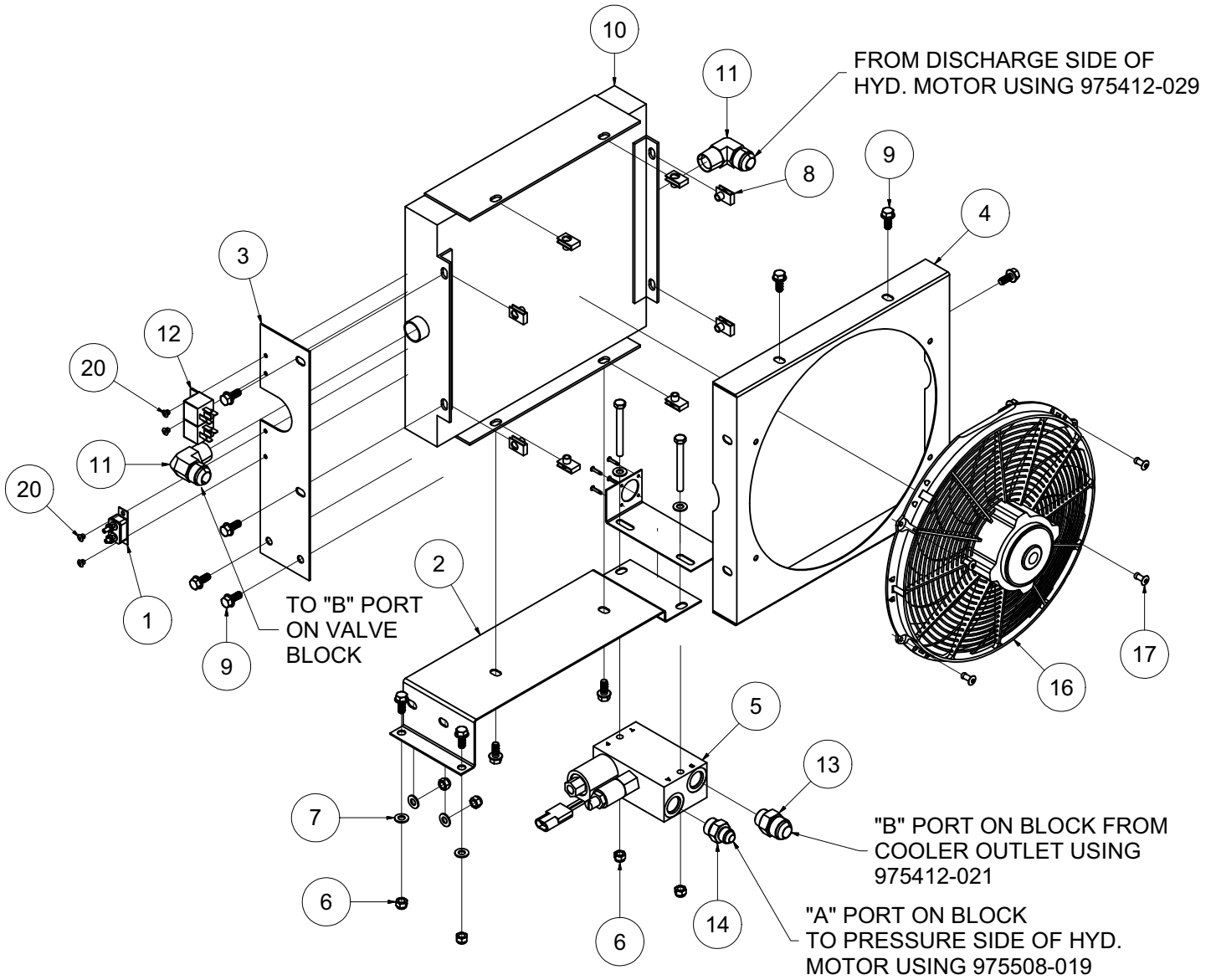

# Piston System

Parts List				Parts List			
ITEM	QTY	PART NUMBER	DESCRIPTION	ITEM	QTY	PART NUMBER	DESCRIPTION
1	4	308227	ROD	29	1	902915-015	PLUG
2	4	308119	RING	30	1	902915-020	PLUG
3	8	308120	RING	31	2	900000-005	PLUG
4	4	308121	PISTON	32	9	930005-075	BOLT
5	1	308122	COLLAR	33	12	925205-273	NUT
6	1	309384	CRANKSHAFT	34	1	309388	KEY
7	1	308123	BEARING	35	12	308141	STUD
8	1	308124	BEARING	36	1	308142	PIN
9	1	308125	PIN	37	1	309389	DIPSTICK
10	1	309385	HOUSING	38	1	308143	GASKET
11	1	308126	BEARING	39	2	308144	GASKET
12	1	308127	SEAL	40	2	308145	GASKET
13	1	308128	HOUSING	41	1	308149	CAP
14	1	308129	BEARING	42	1	308146	PUMP
15	17	929105-100	BOLT	43	4	902915-030	PLUG
16	5	938005-078	WASHER	44	1	903315-020	ELBOW
17	1	308130	CLAMP	45	1	922108-070	NIPPLE
18	1	308131-006	GASKET	46	1	971612-050	BUSHING
19	1	308131-010	GASKET	47	2	308147	GASKET
20	2	308132	GASKET	48	12	938604-071	WASHER
21	3	308131-020	GASKET	49	2	308148	HEAD
22	1	308133	TUBE	50	4	308186	PIN
23	1	308134	SCREEN	51	2	308139	REED VALVE
24	1	308135	COVER	52	2	308229	CYLINDER BLOCK
25	1	308136	BUSHING	53	1	308059	CRANKCASE
26	1	308137	SPRING	54	4	929806-175	BOLT
27	12	308138	WASHER	55	4	938206-071	WASHER
28	1	309387	TUBE	56	4	925506-198	NUT

# Piston System

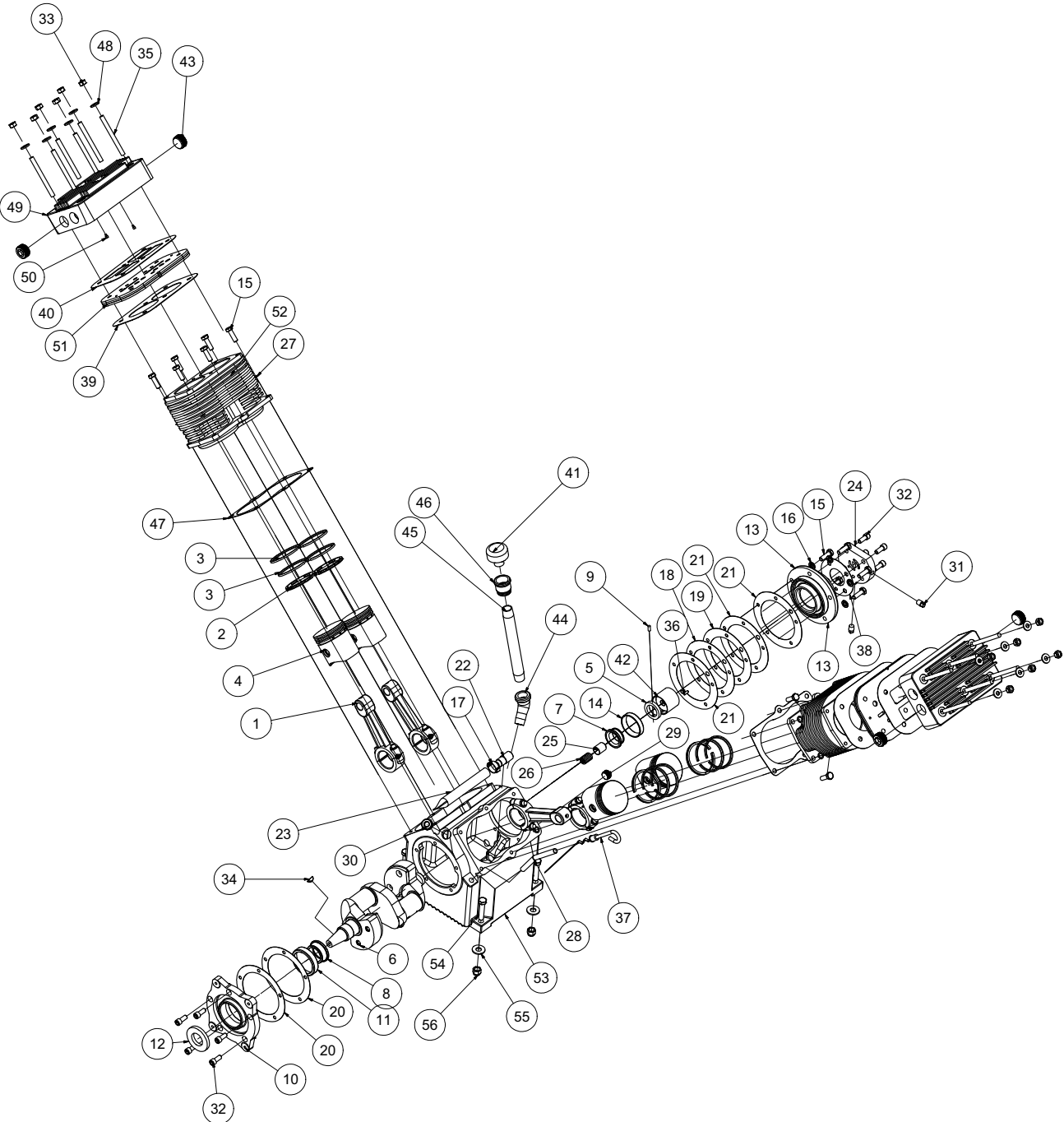

# Air Inlet System

Parts List			
ITEM	QTY	PART NUMBER	DESCRIPTION
1	1	300855	BAND
2	1	301418	SLEEVE
3	1	301417	SLEEVE
4	2	301602	ISOLATOR
5	1	304566	TUBE
6	1	300857	CAP
7	2	938605-071	WASHER
8	2	924305-166	NUT
9	1	301438	FILTER
10	2	304515	ADAPTOR
11	2	309383	CAP
12	1	304534	TUBE
13	1	301446	BRACKET
14	2	929704-050	BOLT
15	2	929705-125	BOLT

# Air Inlet System

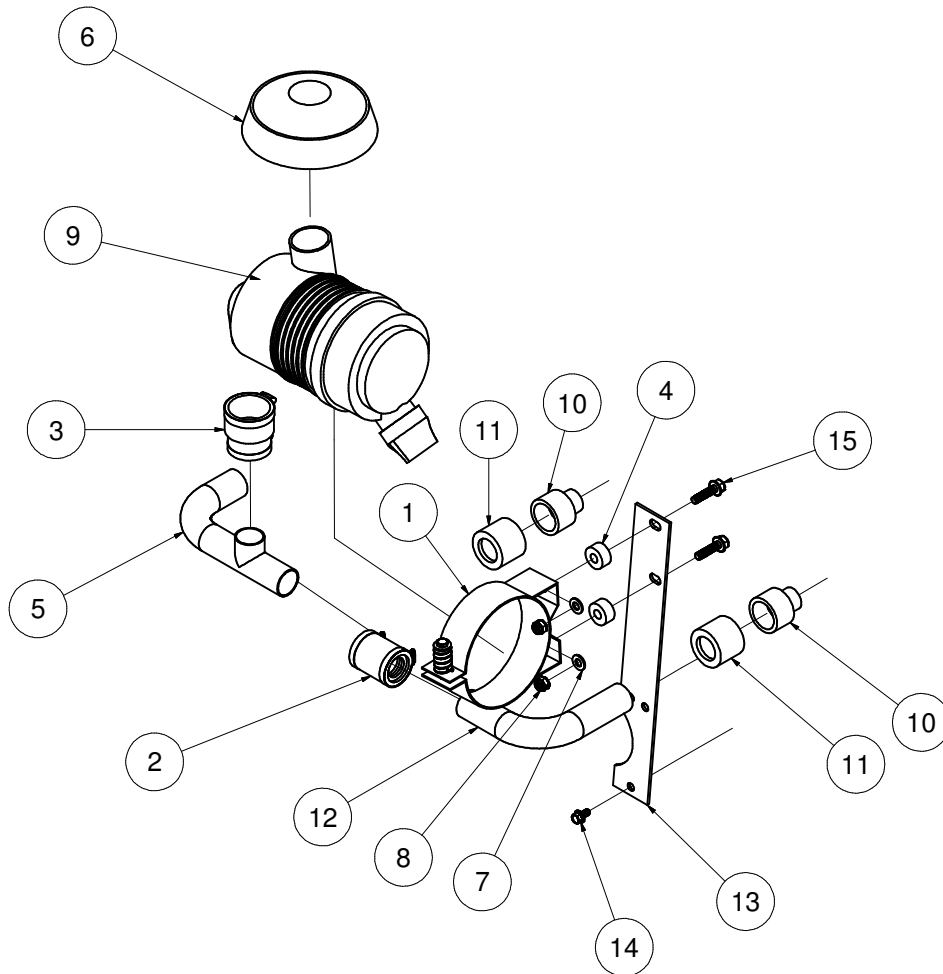

# Discharge System

Parts List			
ITEM	QTY	PART NUMBER	DESCRIPTION
1	4	938206-071	WASHER
2	2	925506-198	NUT
3	1	303202	BRACKET
4	1	301578	SWITCH
5	1	308152	SWITCH
6	1	975104-012	ELBOW
7	1	301928-125	CLAMP
8	1	934504-075	SCREW
9	1	301142	VALVE
10	1	960112-075	CONNECTOR
11	1	960212-075	ELBOW
12	1	961912-075	TEE
13	2	960012-075	ELBOW
14	1	305268	HOSE
15	2	929806-100	BOLT
16	1	902415-020	TEE
17	1	922212-000	NIPPLE
18	1	902203-022	TEE
19	1	922108-060	NIPPLE
20	1	961608-025	NIPPLE
21	1	922108-020	NIPPLE
22	1	305328	HOSE
23	2	943102-038	RIVET



# Discharge System

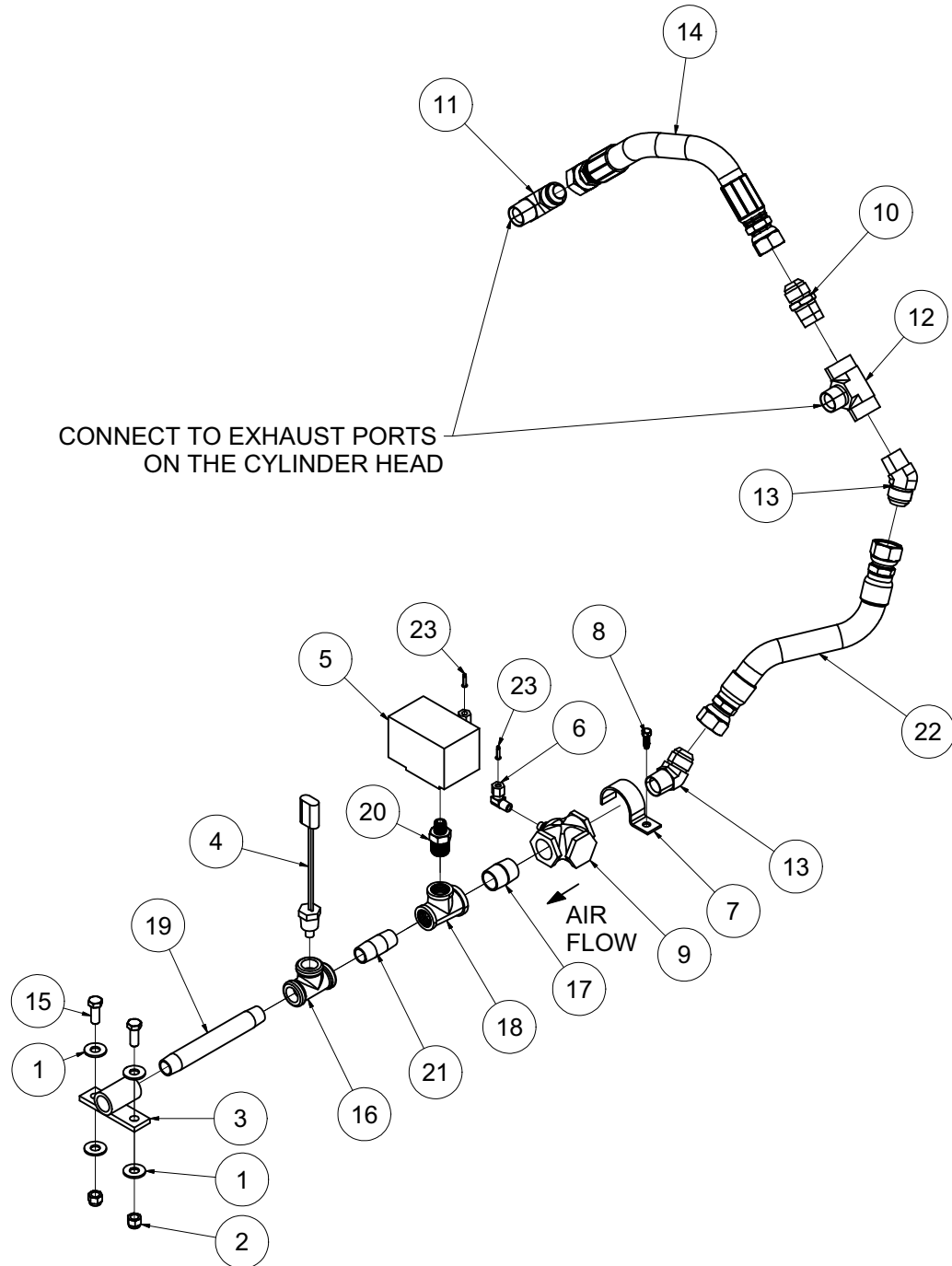

# Canopy System

Parts List			
ITEM	QTY	PART NUMBER	DESCRIPTION
1	1	304832	CANOPY
2	20	977004-062	WASHER
3	14	961504-090	NUT
4	1	301436	PANEL
5	1	301435	PANEL
6	20	983904-075	BOLT
7	20	984004-071	WASHER

# Canopy System

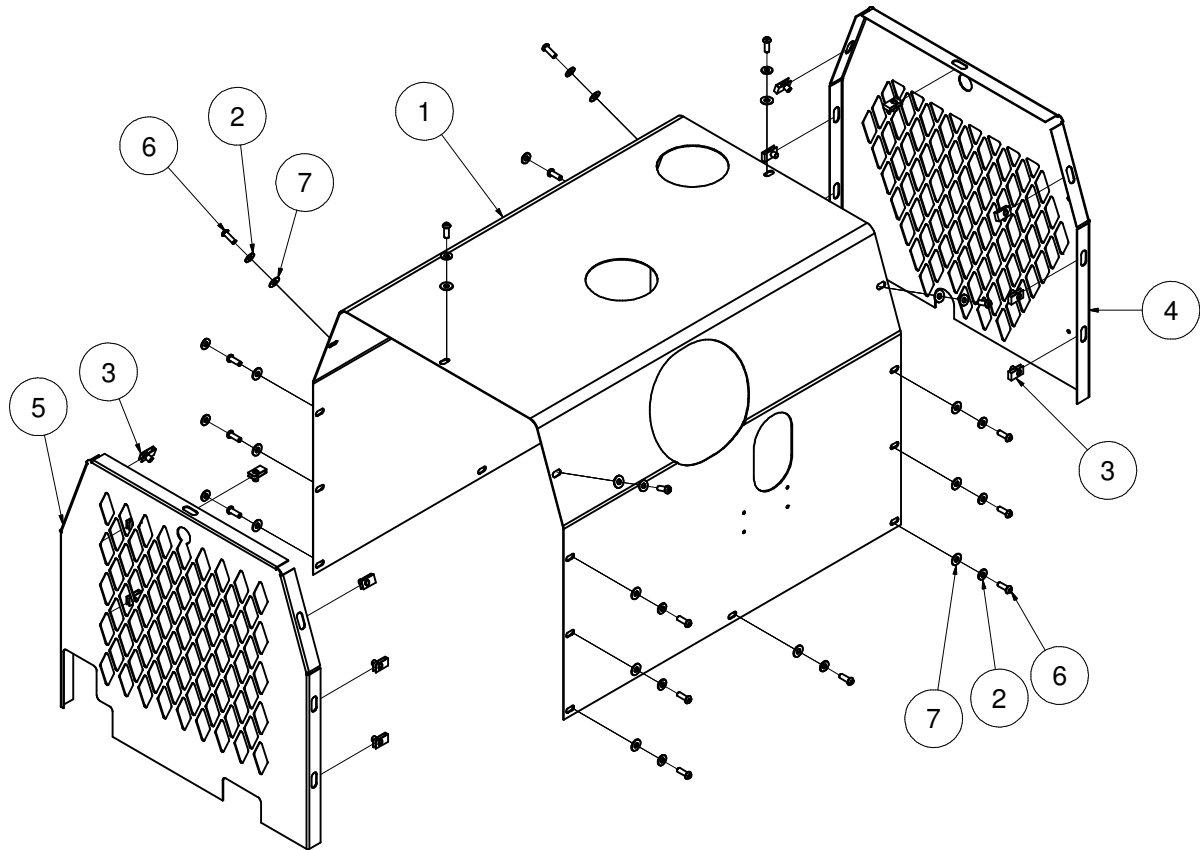

# Oil Drain System

Parts List			
ITEM	QTY	PART NUMBER	DESCRIPTION
1	1	302614	HOSE
2	1	922106-035	NIPPLE
3	1	901515-015	ELBOW
4	2	302613	CLIP
5	2	943103-025	RIVET

# Oil Drain System

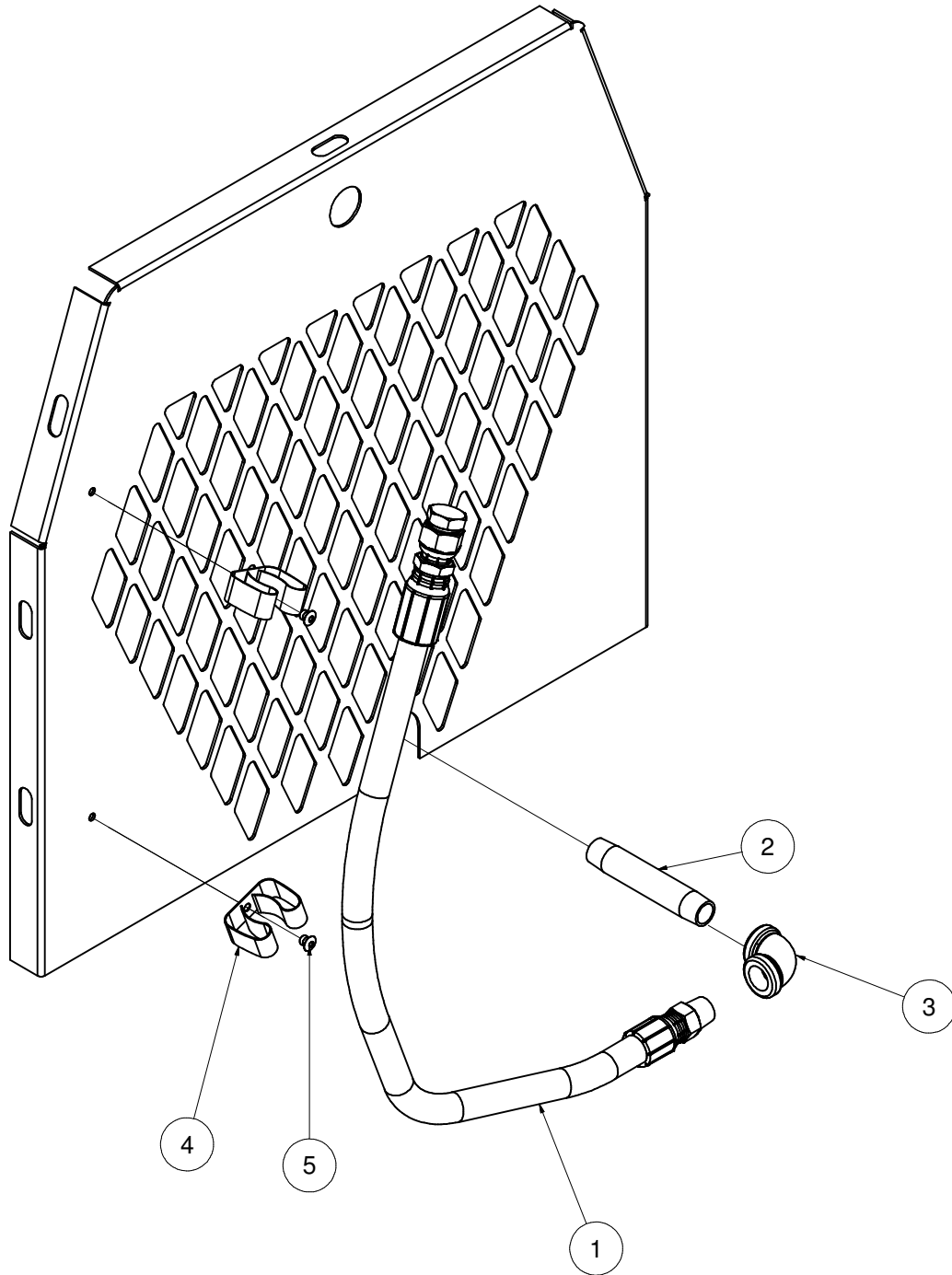

# Mounting System

Parts List			
ITEM	QTY	PART NUMBER	DESCRIPTION
1	4	308082	BUMPER
2	4	929806-200	BOLT
3	4	938206-071	WASHER

# Mounting System

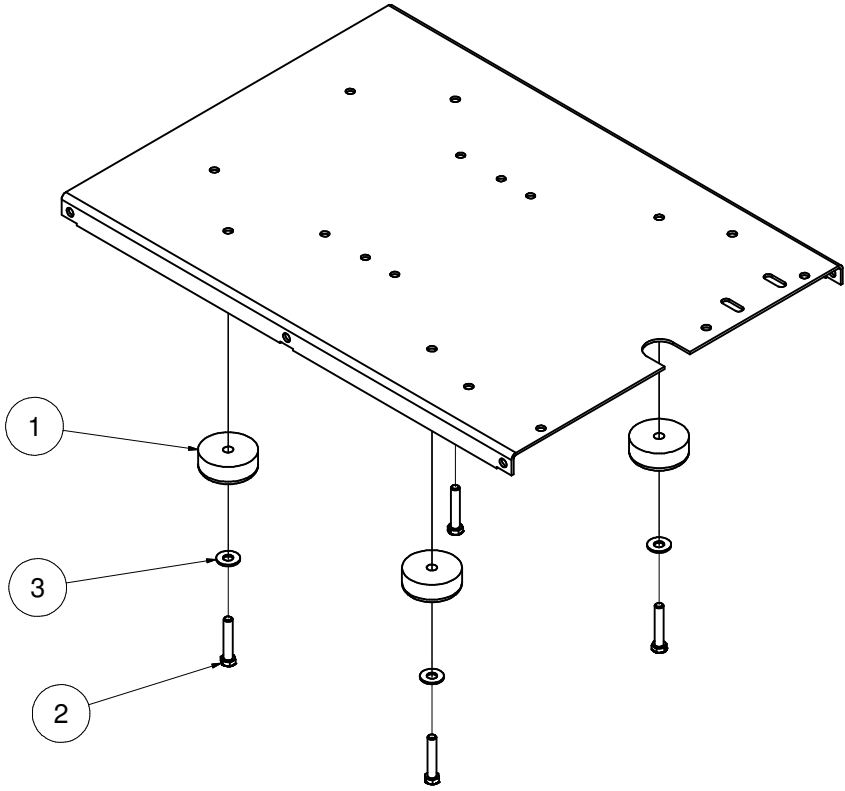

# Decal System

Parts List			
ITEM	QTY	PART NUMBER	DESCRIPTION
1	1	309392	DECAL, BA435 SHEET
1.1	2	309392-01	DECAL, BA435 LOGO
1.2	1	309392-02	DECAL, OIL DRAIN
1.3	1	309392-03	DECAL, VALVE BLOCK
1.4	1	309392-04	DECAL, AIR
1.5	1	309392-05	DECAL, WARNING CONNECT AIR
1.6	1	309392-06	DECAL, DANGER BREATHING
1.7	1	309392-07	DECAL, WARNING READ MANUAL
1.8	1	309392-08	DECAL, WARNING FAN GUARD
1.9	1	309392-09	DECAL, DRIVE COUPLING
1.10	1	309392-10	DECAL, OIL LEVEL
1.11	2	309392-11	DECAL, RESTRICT AIRFLOW
2	1	305761	DECAL, SERIAL TAG BOSS



# Decal System

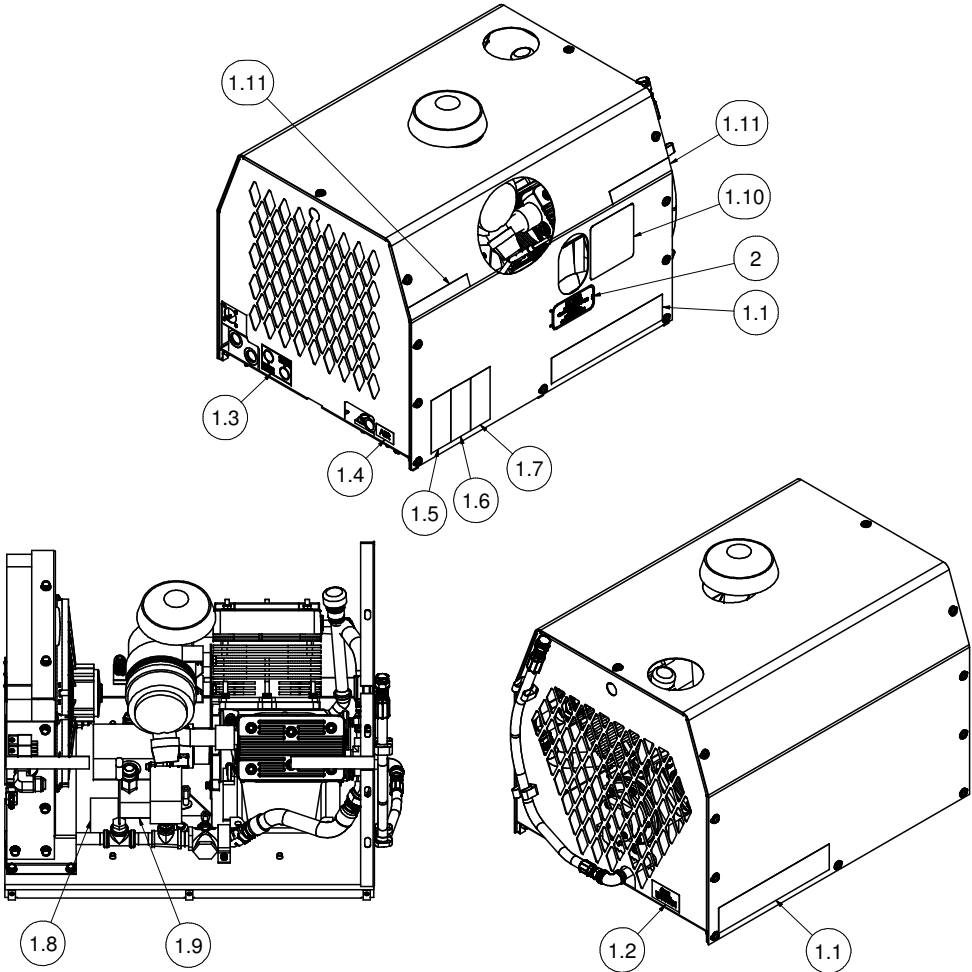

# System Schematic

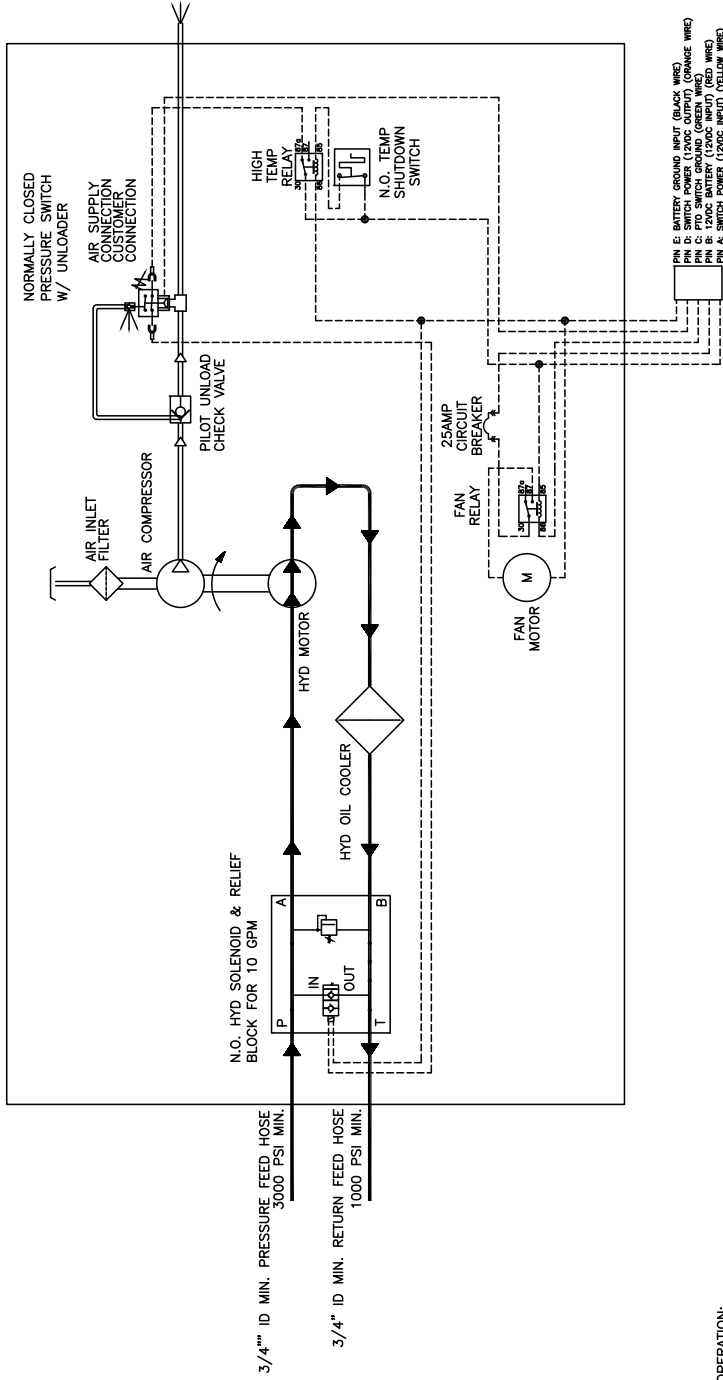
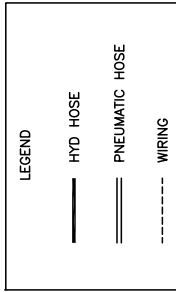

**OPERATION:**

PIN "B" AND PIN "E" ARE TO BE CONNECTED DIRECTLY TO BATTERY POSITIVE (PIN "B" RED WIRE) AND BATTERY NEGATIVE (PIN "E" BLACK WIRE).

COMPRESSOR: FOR NORMAL COMPRESSOR OPERATION, SUPPLY 12VDC INPUTS TO PIN "A" (YELLOW WIRE). THIS WILL ACTIVATE THE SYSTEM AND PRESSURE THE TANK TO 150 PSI. THE SYSTEM WILL THEN UNLOAD UNTIL THE TANK HAS DROPPED TO 110 PSI, AT WHICH POINT IT WILL AUTOMATICALLY ACTIVATE. THE 12VDC OUTPUT SIGNAL FROM PIN "D" (ORANGE WIRE) WILL BE PRESENT ONLY WHEN THE SYSTEM IS COMPRESSING.

PIN "C" (GREEN WIRE) IS CONNECTED TO PTO SWITCH GROUND. THIS WILL ALLOW THE FAN TO RUN ONLY WHEN THE PTO IS ENGAGED.